

## Small Signal Schottky Diode

### Features

- For general purpose applications
- This diode features low turn-on voltage and high break-down voltage.
- This device is protected by a PN junction guard ring against excessive voltage, such as electrostatic discharges.
- This diode is also available in the DO-35 case with type designation BAT41.

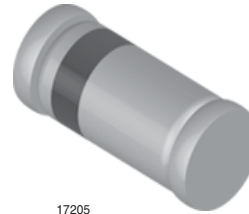

17205

### Mechanical Data

**Case:** MiniMELF Glass case (SOD-80)

**Weight:** approx. 31 mg

**Packaging Codes/Options:**

GS18 / 10 k per 13" reel (8 mm tape), 10 k/box

GS08 / 2.5 k per 7" reel (8 mm tape), 12.5 k/box

### Parts Table

Part	Ordering code	Marking	Remarks
LL41	LL41-GS18 or LL41-GS08	-	Tape and Reel

### Absolute Maximum Ratings

$T_{amb} = 25\text{ }^{\circ}\text{C}$ , unless otherwise specified

Parameter	Test condition	Symbol	Value	Unit
Repetitive peak reverse voltage		$V_{RRM}$	100	V
Forward continuous current	$T_{amb} = 25\text{ }^{\circ}\text{C}$	$I_F$	100 <sup>1)</sup>	mA
Repetitive peak forward current	$t_p < 1\text{ s}$ , $\delta < 0.5$ , $T_{amb} = 25\text{ }^{\circ}\text{C}$	$I_{FRM}$	350 <sup>1)</sup>	mA
Surge forward current	$t_p = 10\text{ ms}$ , $T_{amb} = 25\text{ }^{\circ}\text{C}$	$I_{FSM}$	750 <sup>1)</sup>	mA
Power dissipation <sup>1)</sup>	$T_{amb} = 25\text{ }^{\circ}\text{C}$	$P_{tot}$	400 <sup>1)</sup>	mW

<sup>1)</sup> Valid provided that electrodes are kept at ambient temperature

### Thermal Characteristics

$T_{amb} = 25\text{ }^{\circ}\text{C}$ , unless otherwise specified

Parameter	Test condition	Symbol	Value	Unit
Thermal resistance junction to ambient air		$R_{thJA}$	300 <sup>1)</sup>	$^{\circ}\text{C}/\text{W}$
Junction temperature		$T_j$	125	$^{\circ}\text{C}$
Ambient operating temperature range		$T_{amb}$	- 65 to + 125	$^{\circ}\text{C}$
Storage temperature range		$T_S$	- 65 to + 150	$^{\circ}\text{C}$

<sup>1)</sup> Valid provided that electrodes are kept at ambient temperature

### Electrical Characteristics

$T_{amb} = 25\text{ }^{\circ}\text{C}$ , unless otherwise specified

Parameter	Test condition	Symbol	Min	Typ.	Max	Unit
Reverse breakdown voltage	100 $\mu\text{A}$ / 300 $\mu\text{s}$ pulses	$V_{(BR)R}$	100	110		V
Leakage current	Pulse test $t_p = 300\text{ }\mu\text{s}$ , $V_R = 50\text{ V}$ , $T_j = 25\text{ }^{\circ}\text{C}$	$I_R$			100	nA
	Pulse test $t_p = 300\text{ }\mu\text{s}$ , $V_R = 50\text{ V}$ , $T_j = 100\text{ }^{\circ}\text{C}$	$I_R$			20	$\mu\text{A}$
Forward voltage	Pulse test $t_p = 300\text{ }\mu\text{s}$ , $I_F = 1\text{ mA}$	$V_F$		0.40	0.45	V
	Pulse test $t_p = 300\text{ }\mu\text{s}$ , $I_F = 200\text{ mA}$	$V_F$			1.0	V
Capacitance	$V_R = 1\text{ V}$ , $f = 1\text{ MHz}$			2		pF
Reverse recovery time	$I_F = 10\text{ mA}$ , $I_R = 10\text{ mA}$ , $I_{rr} = 1\text{ mA}$ , $R_L = 100\text{ }\Omega$	$t_{rr}$		5		ns

### Package Dimensions in mm (Inches)

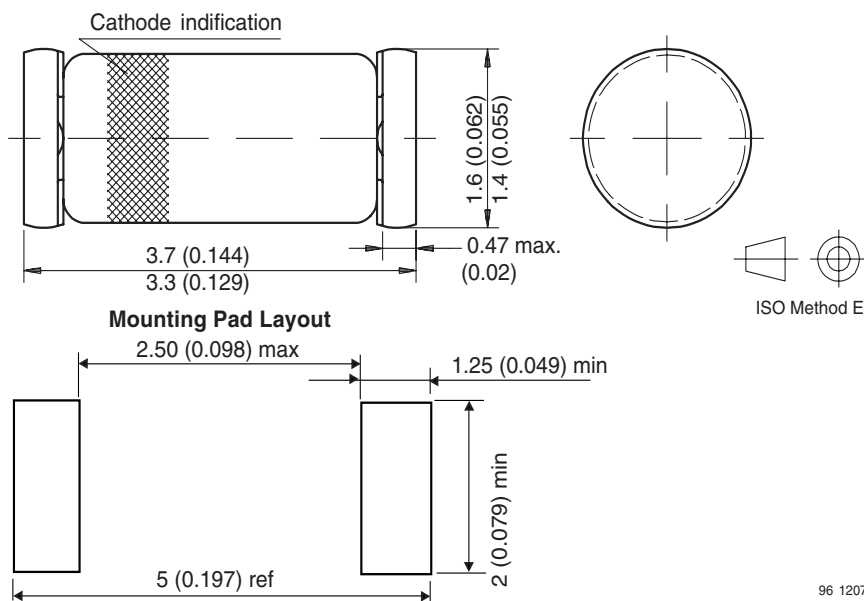

## Ozone Depleting Substances Policy Statement

It is the policy of Vishay Semiconductor GmbH to

1. Meet all present and future national and international statutory requirements.
2. Regularly and continuously improve the performance of our products, processes, distribution and operating systems with respect to their impact on the health and safety of our employees and the public, as well as their impact on the environment.

It is particular concern to control or eliminate releases of those substances into the atmosphere which are known as ozone depleting substances (ODSs).

The Montreal Protocol (1987) and its London Amendments (1990) intend to severely restrict the use of ODSs and forbid their use within the next ten years. Various national and international initiatives are pressing for an earlier ban on these substances.

Vishay Semiconductor GmbH has been able to use its policy of continuous improvements to eliminate the use of ODSs listed in the following documents.

1. Annex A, B and list of transitional substances of the Montreal Protocol and the London Amendments respectively
2. Class I and II ozone depleting substances in the Clean Air Act Amendments of 1990 by the Environmental Protection Agency (EPA) in the USA
3. Council Decision 88/540/EEC and 91/690/EEC Annex A, B and C (transitional substances) respectively.

Vishay Semiconductor GmbH can certify that our semiconductors are not manufactured with ozone depleting substances and do not contain such substances.

We reserve the right to make changes to improve technical design and may do so without further notice.

Parameters can vary in different applications. All operating parameters must be validated for each customer application by the customer. Should the buyer use Vishay Semiconductors products for any unintended or unauthorized application, the buyer shall indemnify Vishay Semiconductors against all claims, costs, damages, and expenses, arising out of, directly or indirectly, any claim of personal damage, injury or death associated with such unintended or unauthorized use.

Vishay Semiconductor GmbH, P.O.B. 3535, D-74025 Heilbronn, Germany  
Telephone: 49 (0)7131 67 2831, Fax number: 49 (0)7131 67 2423