

## MicroTCA MTC600 Series

600 Watts

Total Power: 600 Watts  
# of Channels: 16



**μTCA™**

### Special Features

- 600 W output power
- 16 Channels of
  - 12 V @ 7.6 A max
  - 3.3 V @ 150 mA max
- Supports:
  - 12x AMC's
  - 2x MCH's
  - 2x CU's
- Supports N+1 output redundancy, N≤3
- Supports 1+1 input redundancy

### Compliance

- PICMG MicroTCA.0 (Revision 1.0)
- PICMG HPM.1 Firmware Upgrade (Revision 1.0)

### Safety

UL, cUL 60950-1  
CSA 60950-1  
VDE 60950-1

## Product Description

### General

The MTC600 series of Power Modules are designed for use in MicroTCA systems and can support shelves, cube and other implementations and is compliant to PICMG MicroTCA .0 Revision 1.0 specification.

The MTC600 Power Modules implement the functionality necessary to power, manage and protect a MicroTCA system comprising up to:

- 12x AdvancedMCs
- 2x MicroTCA Carrier Hubs
- 2x Cooling Units

The MTC600 Power Modules will:

- On system bring-up, provide the power necessary for MCH and CU system elements.
- Support redundant IPMI (IPMB-0) communication with the MCH/Carrier-Manager
- Under the command of the carrier manager, enable and provide power to AMCs, CUs and additional MCHs
- Monitor and Report power system status and conditions of operation
- Manage and isolate faults affecting the power system

## Product Description (continued)

Rev. 05.26.08  
MTC600 Series  
2 of 19

### Input

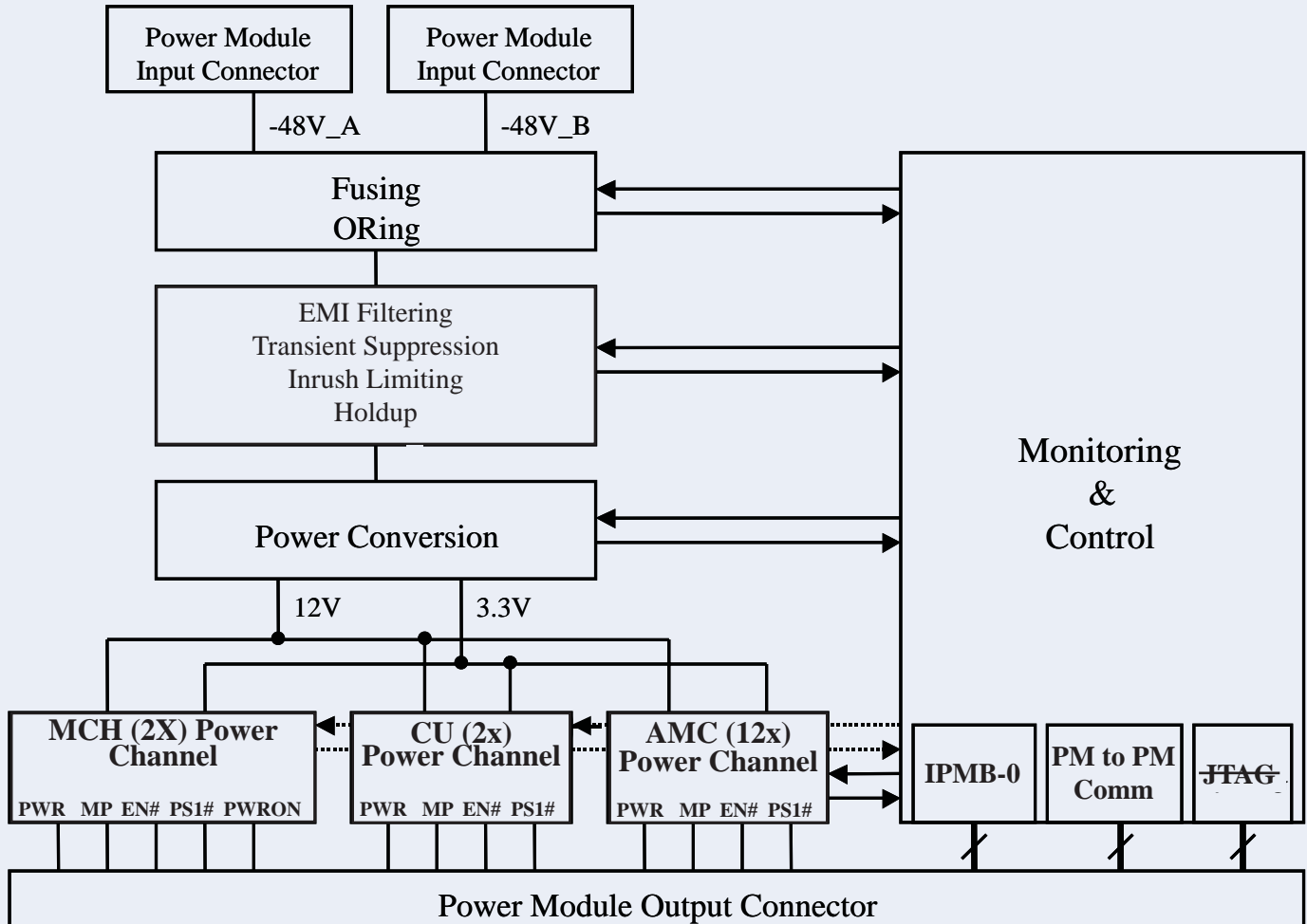

# Electrical Specifications

Input		
<b>-48 Vdc Models</b>		
Input Range (Operating)	-39.5 to -72 Vdc	Supports -48 V and -60 V battery plants
Input Range (Non-operating)	0 to -39.5 Vdc -72 to -75 Vdc	Power Module may or may not operate in part of this range, but will not be damaged
Input Fusing	Internal 24 A Fuses	In both A & B feeds and A & B return lines
Input ORing	Internal	In both A & B feeds and A & B return lines
Inrush Current	≤80 A	For t < 1 ms
Input Current	12.8 A 18.2 A	Typical with 600 W out, -54.0 Vin Maximum with 600 W out, -39.5 Vin
Holdup Time	5 ms 7 ms 10 ms 10 ms	Minimum at 600 W with one PM Typical at 600 W with one PM Typical at 400 W with one PM Minimum at 600 W with two PMs
UnderVoltage Lockout	39.5 ±1.0 V 37.0 ±1.0 V	Turn-On voltage Turn-Off voltage
Reverse Polarity Protection	Included	Protected against reverse polarity over magnitude of specified input range
<b>AC Models</b>		
Input Range (Operating)	90 to 264 Vac	Supports typical worldwide single-phase inputs
Input Range (Non-operating)	0 to 90 Vac 264 to 282 Vac	Power Module may or may not be operating in part of this range, but will not be damaged
Frequency	47 to 63 Hz	
Input Fusing	Internal 15 A Fuses	
Inrush Current	≤45 A	I <sup>2</sup> t integral compatible with 15 A fast-blow fuse
Power Factor	0.99 typical	Meets EN61000-3-2
Harmonics	<2.30 Arms (odd) <1.08 Arms (even)	
Input Current	2.95 A 6.6 A	Typical with 600 W out, 230 Vac Maximum with 600 W out, 110 Vac
Holdup Time	16.7 ms 20 ms	At 110 Vac, 60 Hz At 230 Vac, 50 Hz
UnderVoltage Lockout	87 ± 2.5 V 83 ± 2.5 V	Turn-On voltage Turn-off voltage
OverVoltage Lockout	282 Vac	Power Module will turn-off if input voltage exceeds this voltage and not turn on until input voltage is reduced below this level

## Electrical Specifications (continued)

Output - All Models (continued)		
<b>12 V Outputs (Payload Power)<sup>1,2</sup></b>		
Management Power Interdependence	12 V will not be applied without 3.3 V applied to a load	Removal of 3.3 V also removes 12 V and de-asserts ENABLE#
Setpoint	12.6 Vdc typical 11.8 Vdc typical	Configured as Primary PM Configured as Redundant PM
Total Regulation Range	12.25 to 12.95 Vdc 11.60 to 12.00 Vdc	Configured as Primary PM Configured as Redundant PM
Rated Load	600 W maximum 80 W / 7.6 A maximum	Per Power Module, input voltage $\geq$ 110 Vac Per load channel
Minimum Load	No load	No loss of regulation $\geq$ 110 Vrms
Output Rise Time (per channel)	25 ms maximum	With 1600 $\mu$ F on output under test
Output Noise (PARD) <sup>3</sup>	75 mV maximum 100 mV maximum	0 to 30 MHz 0 to 100 MHz
Output Voltage Overshoot	2% maximum	Referenced to setpoint
Transient Response	3% maximum deviation 2 ms recovery time	2 A loadstep @ 1 A/ $\mu$ s Referenced to load current and setpoint at onset of transient. Recovery time to within 1% of setpoint at onset of transient
Voltage Sag	1.00 V maximum	Primary PM to redundant PM transition with maximum of 80 W load per output or 600 W load per PM
Short Circuit Protection	9.7 A maximum 10 ms maximum	Output to return
Channel Fault Operation (Output to Return)	12V Payload Power Output under fault is shutdown. 3V3 MP on the same channel is not affected. The other channels are not affected	After removal of fault, the output channel is available again under control of the Carrier Manager. PM_OK# is not de-asserted and redundant failover is not initiated
Channel Fault Operation (Output to Output)	No damage to Power Module	Either or both outputs may shut down until fault is removed
PS1# Extraction Delay	100 $\mu$ s maximum	Time from de-assertion of PS1# to disabling of the channel outputs and de-assertion of the ENABLE# signal
Reflected Ripple Tolerance on Cooling Unit Outputs <sup>4</sup>	100 mV pk-pk 0.8 A pk-pk	Tolerance of Power Module to ripple generated by fans or motors connected to Payload Power on Cooling Units

**Note 1:** All channels and outputs must be configured by the carrier manager with the exception of MCH and CU channels and outputs which are configured during Startup and/or autonomous operation,

**Note 2:** All measurements are made at the output connector of the Power Module. Unless otherwise specified, specs apply to all AMC, MCH, and CU outputs.

**Note 3:** Measured with a 0.1  $\mu$ F ceramic and 10  $\mu$ F tantalum capacitor on any output and oscilloscope bandwidth set for 200 MHz.

**Note 4:** Consult with the factory if other outputs are expected to product significant ripple current.

## Electrical Specifications (continued)

Output - All Models (continued)		
<b>3.3 V Outputs (Management Power) <sup>5,6</sup></b>		
Payload Power Interdependence	3.3 V must be applied before 12 V	Removal of 3.3 V also removes 12 V and de-asserts ENABLE#
Setpoint	3.3 Vdc typical	
Total Regulation Range	3.16 to 3.63 Vdc	
Rated Load	8 W maximum 0.5 W / 150 mA maximum	Per Power Module Per load channel
Minimum Load	No load	No loss of regulation
Output Rise Time (per channel)	25 ms maximum	With 150 $\mu$ F on output under test
Output Noise (PARD) <sup>3</sup>	50 mV maximum 75 mV maximum	0 to 30 MHz 0 to 100 MHz
Output Voltage Overshoot	2% maximum	Referenced to setpoint
Transient Response	3% maximum deviation 2 ms recovery time	37.5 mA loadstep @ 1 A/ $\mu$ s Referenced to load current and setpoint at onset of transient. Recovery time to within 1% of setpoint at onset of transient
Voltage Sag	150 mV maximum	Primary PM to redundant PM transition with max of 80 W load per output or 600 W load per PM
Short Circuit Protection	225 mA maximum 12 ms maximum	Output to return
Channel Fault Operation (Output to Return)	Output channel under fault is shutdown. Both 3.3V and 12V are removed and ENABLE# is de-asserted. The other channels are not affected	After removal of fault, the output channel is available again under control of the Carrier Manager. PM_OK# is not de-asserted and redundant failover is not initiated
Channel Fault Operation (Output to Output)	No damage to Power Module	Either or both channels may shut down until fault is removed
PS1# Extraction Delay	100 $\mu$ s maximum	Time from de-assertion of PS1# to disabling of the channel outputs and de-assertion of the ENABLE# signal

**Note 5:** All channels and outputs must be configured by the carrier manager with the exception of MCH and CU channels and outputs which are configured during Startup and/or autonomous operation.

**Note 6:** All measurements are made at the output connector of the Power Module. Unless otherwise specified, specs apply to all AMC, MCH, and CU outputs.

## Electrical Specifications (continued)

Output - All Models (continued)		
<b>General</b>		
Turn-on Time	4 seconds maximum	After power-on of the PM, the time for autonomous outputs to reach regulation band
Early Power	Supported	PM supports Early Power requirements referenced in MicroTCA.0 Rev 1.0 Section 4.4.11.1
Normal Power	Supported	PM supports Normal Power requirements referenced in MicroTCA.0 Rev 1.0 Section 4.4.11.2
Autonomous Operation	Supported	PM supports Autonomous Operation requirements referenced in MicroTCA.0 Rev 1.0 Section 4.4.11.3
Diagnostic Mode	Supported [GA2,GA1,GA0] = 101, or [GA2,GA1,GA0] = 110 LED1 displays yellow	In Diagnostic Mode PM disables the IPMI controls and slots are powered up based only on PSI# signals
<b>Redundancy<sup>7</sup></b>		
Hot-Swap Operation (controlled)	Supported	Removal or addition of a PM will not cause a fault or out-of-regulation condition
Hot-Swap Operation (uncontrolled)	Supported	Removal or addition of a PM will not cause a fault or out-of-regulation condition
Power Module Failover	Supported	When configured as a redundant PM, the PM is capable of accepting the load of a failed PM within specified voltage magnitude and timing parameters
Fault Isolation	Supported	A fault in one PM will not cause the shutdown of another PM

**Note 7:** All specifications in the redundancy sub-section assume the system is populated with Power Modules with the same manufacturer's model numbers or otherwise compatible Power Modules. At the time of print, PICMG does not have a formal methodology for verifying compatibility.

## Electrical Specifications (continued)

### Input Signals - All models

**Geographic Address:** GA0, GA1, GA2

Internal pull ups to 3.3 V. Source current limited by 11 Kohm (300  $\mu$ A with GAx at 0.0 V)

	MIN	MAX
Logic Level Low - $V_{IL}$		0.5 V
Logic Level High- $V_{IH}$	1.63 V	

**PS1\_[SLOT]#:** PS1\_M1, PS1\_M2, PS1\_CU1, PS1\_CU2, PS1\_1, ...PS\_12

Internal pull ups to 3.3 V. Source current limited by 10 Kohm (330  $\mu$ A with PS1\_[SLOT]# at 0.0 V)

	MIN	MAX
Logic Level Low Voltage - $V_{IL}$		1.1 V
Logic Level High Voltage - $V_{IH}$	2.6 V	

**PWRON\_[MCH]:** PWRON\_MI, PWRON\_M2

Internal 10 Kohm pull down. Compatible with MicroTCA.0 R1.0 Section A.5.4

	MIN	MAX
Logic Level Low - $V_{IL}$		0.5 V
Logic Level High - $V_{IH}$	1.63 V	

**RST\_PM\_IN#:** RST\_PM\_IN#

	MIN	MAX
Logic Level Low - $V_{IL}$		0.6 V
Logic Level High - $V_{IH}$	2.4 V	

**PMP\_[x]#:** PMP\_A#, PMP\_B#, PMP\_C#

Internal pull up to 3.3 V. Source current limited by 10 Kohm (330  $\mu$ A with PMP\_[x]# at 0.0 V)

	MIN	MAX
Logic Level Low Voltage - $V_{IL}$		0.5 V
Logic Level High Voltage - $V_{IH}$	1.63 V	

**PS\_PM#:** PS\_PM#

Internal pull up to 3.3 V. Source current limited by 10 Kohm

	MIN	MAX
Logic Level Low Voltage - $V_{IL}$		0.6 V
Logic Level High Voltage - $V_{IH}$	2.4 V	

## Electrical Specifications (continued)

### Output Signals - All Models

**EN1\_[SLOT]#:** EN1\_M1, EN1\_M2, EN1\_CU1, EN1\_CU2, EN1\_1, EN1\_2...EN1\_12  
Open collector output. Isink, max=10 mA. No internal current limit

	MIN	MAX
Logic Level Low Voltage - $V_{OL}$		0.8 V
Voltage Withstand - $V_{max}$		5.5 V

### PM\_OK#: PM\_OK#

Open collector output, Isink max = 10 mA. No current limit

	MIN	MAX
Logic Level Low Voltage - $V_{OL}$		0.8 V
Voltage Withstand - $V_{max}$		5.5 V

### RST\_PM\_[x]#: RST\_PM\_A#,RST\_PM\_B#,RST\_PM\_C#

Open collector output, Isink, max = 10 mA. No current limit

	MIN	MAX
Logic Level Low Voltage, - $V_{OL}$		0.8 V
Voltage Withstand - $V_{max}$		5.5 V

### Shared Signals - All Models

#### SMP: SMP

Compliant to MicroTCA.0 R1.0 Section 4.6.5.4.3, requirements 4.221-4.225

	MIN	MAX
Voltage Range	4.5 V	6 V
Isink		750 mA
Isource		350 mA



## Electrical Specifications (continued)

### I<sup>2</sup>C Interface - All Models

#### Operating Parameters

I <sup>2</sup> C Operating Voltage	3.3 V	Nominal
I <sup>2</sup> C Operating Frequency	100 kHz	

#### SDA\_[x]: SDA\_A, SDA\_B

Internal pull ups to 3.3 V. Source current limited by 10 Kohm (330  $\mu$ A with SDA\_[x] at 0.0 V). Buffered to support hot-swap

	MIN	MAX
Logic Level Low - V <sub>IL</sub>		0.7 V
Logic Level High - V <sub>IH</sub>	2.70 V	

#### SCL\_[x]: SCL\_A, SCL\_B

Internal pull ups to 3.3 V. Source current limited by 10 Kohm (330  $\mu$ A with SCL\_[x] at 0.0 V). Buffered to support hot-swap.

	MIN	MAX
Logic Level Low Voltage - V <sub>IL</sub>		0.7 V
Logic Level High Voltage - V <sub>IH</sub>	2.70 V	

# IPMB-0 Interface

## PM-EMMC

**Functionality**  
A PM-EMMC is implemented per MicroTCA.0 R1.0 requirements 4.116 through 4.120

IPM Device	
IPMB Interface	PM-EMMC aggregates IPMB-A and IPMB-B IPMI v1.5 protocol
SDR Repository	
Sensors	Implements mandatory 2 temp sensors; Implements voltage and current sensors
Watchdog Timer	Implements a watchdog timer for resetting PM's own PM-EMMC
FRU Inventory	
Initialization Agent	PM-EMMC is responsible for initializing it's own event generation and sensors
Internal Event Generation	
External Event Generation	Events sent over IPMB-0

**Power Channel Mapping**

Power Channel	Management Power	Payload Power	PS1#	ENABLE#	Autonomous Power
1, 2	MP_M1, MP_M2	PP_M1, PP_M2	PS1_M1#, PS1_M2#	EN_M1#, EN_M2#	Depends on PWRON_M1, PWRON_M2
3, 4	MP_CU1, MP_CU2	PP_CU1, PP_CU2	PS1_CU1#, PS1_CU2#	EN_CU1#, EN_CU2#	Yes
5-16	MP_1 - MP_12	PP_1 - PP_12	PS1_# - PS1-12#	EN_1# - EN_12#	No

## Supported Commands

**Global Commands**  
NetFN App Request=06h; Response=07h

Command	CMD	Note
Get Device ID	01h	As defined in IPMI v1.5; Broadcast Get Device ID not supported
Cold Reset	02h	As defined in IPMI v1.5

**Event Commands**  
NetFN S/E Request=04h; Response=05h

Command	CMD	Note
Set Event Receiver	00h	As defined in IPMI v1.5
Get Event Receiver	01h	As defined in IPMI v1.5
Platform Event	02h	As defined in IPMI v1.5

## IPMB-0 Interface (continued)

### Supported Commands (Continued)

#### Sensor Device Commands

NetFN S/E Request=04h; Response=05h

Command	CMD	Note
Get Device SDR Info	20h	As defined in IPMI v1.5
Get Device SDR	21h	As defined in IPMI v1.5
Reserve Device SDR Repository	22h	As defined in IPMI v1.5
Set Sensor Hysteresis	24h	As defined in IPMI v1.5
Get Sensor Hysteresis	25h	As defined in IPMI v1.5
Set Sensor Threshold	26h	As defined in IPMI v1.5
Get Sensor Threshold	27h	As defined in IPMI v1.5
Get Sensor Reading	2Dh	As defined in IPMI v1.5

#### FRU Device Commands

NetFN Storage Request=0Ah; Response=0Bh

Command	CMD	Note
Get FRU Inventory Area Info	10h	As defined in IPMI v1.5
Read FRU Data	11h	As defined in IPMI v1.5
Write FRU Data	12h	As defined in IPMI v1.5

#### PICMG Commands

NetFN Storage Request=2Ch; Response=2Dh

Command	CMD	Note
Get PICMG Properties	00h	As defined in MicroTCA.0 R1.0
Get FRU LED Properties	05h	As defined in PICMG3.0 R2.0 (ATCA)
Get LED Color Capabilities	06h	As defined in PICMG3.0 R2.0 (ATCA)
Set FRU LED State	07h	As defined in PICMG3.0 R2.0 (ATCA)
Get FRU LED State	08h	As defined in PICMG3.0 R2.0 (ATCA)
Set IPMB State	09h	As defined in PICMG3.0 R2.0 (ATCA)
Get Device Locator Reader ID	0Dh	As defined in PICMG3.0 R2.0 (ATCA)
Get IPMB Link Info	18h	As defined in PICMG3.0 R2.0 (ATCA)

#### MicroTCA Commands

NetFN PICGMG Request=2Ch; Reponse=2Dh

Command	CMD	Note
Power Channel Control	24h	As defined in MicroTCA.0.0 R1.0
Get Power Channel Status	25h	As defined in MicroTCA.0.0 R1.0
PM Reset	26h	As defined in MicroTCA.0.0 R1.0
Get PM Status	27h	As defined in MicroTCA.0.0 R1.0
PM Heartbeat	28h	As defined in MicroTCA.0.0 R1.0

## IPMB-0 Interface (continued)

### Sensors - Mandatory per PICMG and Related Standards

#### Event and Status Sensors

These sensors are implemented according to the requirements and specifications of the relevant standards.

Sensor Name	Sensor Number
Management Controller Device Locator	00h
Power Channel Notification	01h
PM Status	02h
IPMB Physical Link	03h
Hot Swap	04h

#### Temperature Sensors

All temperature sensors have an accuracy of 5%.

All temperature sensors have an offset of -40 °C.

Sensor Name	Sensor Number	Resolution	Applicable Models
Hotspot Temperature	05h	1 °C / bit	All
Ambient Temperature	06h	1 °C / bit	All
Thresholds	Assertion/Deassertion	Comparison Returned	Settable/Readable
Upper Non-Recoverable	Yes	Yes	R
Upper Critical	Yes	Yes	S/R
Upper Non-Critical	Yes	Yes	S/R
Lower Critical	Yes	Yes	S/R
Lower Non-Critical	Yes	Yes	S/R

### Sensors - Non-Mandatory per PICMG and Related Standards

#### Internal Voltage Sensors

All voltage sensors have an accuracy of 2%.

Sensor Name	Sensor Number	Resolution	Applicable Models
12 Volt	07h	100 mV / bit	All
3V3 Volt	08h	50 mV / bit	All
5 V Volt	09h	50 mV / bit	All
Thresholds	Assertion/Deassertion	Comparison Returned	Settable/Readable
Upper Critical	Yes	Yes	S/R
Lower Critical	Yes	Yes	S/R

#### Internal Current Sensors

All current sensors have an accuracy of 2%.

Sensor Name	Sensor Number	Resolution	Applicable Models
12 V Current	0Ah	0.5 A / bit	All
3V3 Volt	0Bh	50 mA / bit	All
Thresholds	Assertion/Deassertion	Comparison Returned	Settable/Readable
Upper Critical	Yes	Yes	S/R

## IPMB-0 Interface (continued)

### Sensors - Non-Mandatory per PICMG and Related Standards (continued)

#### Input Voltage Sensors

All voltage sensors have an accuracy of 2%.

Sensor Name	Sensor Number	Resolution	Applicable Models
AC Input Voltage	0Ch	2.0 V / bit	MTC600-AC only
DC Input Voltage A	0Ch	0.5 V / bit	MTC600-48 only
DC Input Voltage B	0Dh	0.5 V / bit	MTC600-48 only
DC Input Or-ed	0Eh	0.5 V / bit	MTC600-48 only
Thresholds	Assertion/Deassertion	Comparison Returned	Settable/Readable
Upper Critical	Yes	Yes	S/R
Lower Critical	Yes	Yes	S/R
Lower Non-Recoverable	Yes	Yes	R

#### Input Current Sensors

All current sensors have an accuracy of 2%.

Sensor Name	Sensor Number	Resolution	Applicable Models
AC Input Current	0Dh	100 mA / bit	MTC600-AC only
DC Input Current	0Fh	100 mA / bit	MTC600-48 only
Thresholds	Assertion/Deassertion	Comparison Returned	Settable/Readable
No thresholds implemented	n/a	n/a	n/a

## Environmental Specifications

### Temperature and Altitude Derating<sup>8</sup>

60 m below to 1800 m above sea level

Condition	Temperature	Load
Storage Non-Operating	-45 °C to +70 °C	-
Cold Start	-20 °C to -5 °C	Any valid condition
Normal Operation	-5 °C to 45 °C	100%
Short Term Operation <sup>9</sup>	45 °C to 55 °C	Linear derating to 80% at 55 °C

1800 m to 4000 m above sea level

Condition	Temperature	Load
Storage Non-Operating	-45 °C to +70 °C	-
Cold Start	-20 °C to -5 °C	Any valid condition
Normal Operation	-5 °C to 35 °C 35 °C to 45 °C	100% System dependent
Short Term Operation <sup>9</sup>	45 °C to 55 °C	System dependent

### Other Environmental

Criteria	Specification	Reference
Relative Humidity	5% - 95%, non-condensing	GR-63-CORE, R4-7; IEC 60068-2-56, 2-30
Vibration	0.1 g @ 5-100 Hz and back to 5 Hz at a rate of 0.1 octave/min or 1.5 g @ 100-500 Hz with 0.25 octave/min; 1.5 mm @ 2-9 Hz, 0.5 g @ 9-200 Hz	GR-63-CORE, R4-58, R4-59; IEC 60068-2-6, 2-36
Shock	4 g @ 22 ms	IEC 60068-2-27, 2-29
Drop	Packaged: 450 mm drop height; Unpackaged: 25 mm drop height; Transportation: 1.2 m free fall	GR-63-CORE, R4-8, R4-9 IEC 60068-2-32
Fire Resistance	All material UL 94V-1 or better	

### Standards Compliance for Telecommunications Applications

The Power Module will not hinder system compliance to the following environmental specifications:

- Telcordia GR-63-CORE
- Telcordia GR-1089-CORE
- NEBS Level 3, per SR-3580
- ETS300 019-1-1, Part 1-1 (Class 1.2E equipment)
- ETS300 019-1-2, Part 1-2 (Class 2.3 equipment)
- ETS300 019-1-3, Part 1-3 (Class 3.2 equipment)

**Note 8:** 12 CFM airflow for -48 V model; 15 CFM airflow for AC model.

**Note 9:** Short Term Operation defined as total period of not more than 96 consecutive hours and total of not more than 15 days in 1 year.

# Electromagnetic Compatibility

## All Models

### Radiated Emissions

Standard	Limits & Test Parameters	Frequency Range	Criteria
EN55022, Class A	Per Section 6	3 MHz to 1 GHz	N/A
GR-1089-CORE	Per Section 3.2	10 KHz to 10 GHz	N/A

### Conducted Emissions

EN55022, Class A	Per Section 6	150 KHz to 30 MHz	N/A
GR-1089-CORE	Per Section 3.2	10 KHz to 30 MHz	N/A

### ElectroStatic Discharge

EN61000-4-2	8 KV Contact, 15 KV Air discharge	Impulsive	B
-------------	-----------------------------------	-----------	---

### Radiated Immunity

EN61000-4-3	10 V/m (level measure unmodulated) 80% AM, 1 KHz	80 MHz to 1GHz	A
-------------	--	----------------	---

### Conducted Immunity

EN61000-4-6	3 V (level measured unmodulated) 80% AM, 1HKz	150 KHz to 80 MHz	A
-------------	---	-------------------	---

### Voltage Dips & Interruptions

EN61000-4-11	-100% for 10 ms @ 0°; -100% for 10 ms @ 180°; -60% for 100 ms; -30% for 500 ms; -100% for 5 s	Impulsive	B,C
--------------	---	-----------	-----

## AC Models

### Fast Transients

EN61000-4-4	5/50 ns 5 KHz pulse 1 KV direct	Impulsive	B
-------------	------------------------------------	-----------	---

### Surge

EN61000-4-5	1.2/50 μsec pulse 2 KV Line to Earth 1 KV Line to Line	Impulsive	B
-------------	--	-----------	---

## -48 Vdc Models

### Fast Transients

EN61000-4-4	5/50 ns 5 KHz pulse 500 V direct	Impulsive	B
-------------	-------------------------------------	-----------	---

### Surge

EN61000-4-5	1.2/50 μsec pulse 500 V Line to Earth 500 V Line to Line	Impulsive	B
-------------	--	-----------	---

## Mechanical Specifications (continued)

### Front Panel - MTC600-48

Input Connector:  
Positronics QB7W2MN7T2,  
FCI 10070158,  
or equivalent

Mating Connector:  
Positronics QB7W2F00QH0/AA,  
FCI 10070165,  
or equivalent

Pinout:  
P1: Return  
P2: -48 V  
1: Not Used  
2: Not Used

### Front Panel - MTC600-AC

Input Connector:  
IEC 320-C14,  
or equivalent

Mating Connector:  
IEC 320-C13,  
or equivalent

Pinout:  
L: Line  
N: Neutral  
G: Ground

### Front Panel Drawing for DC-input unit

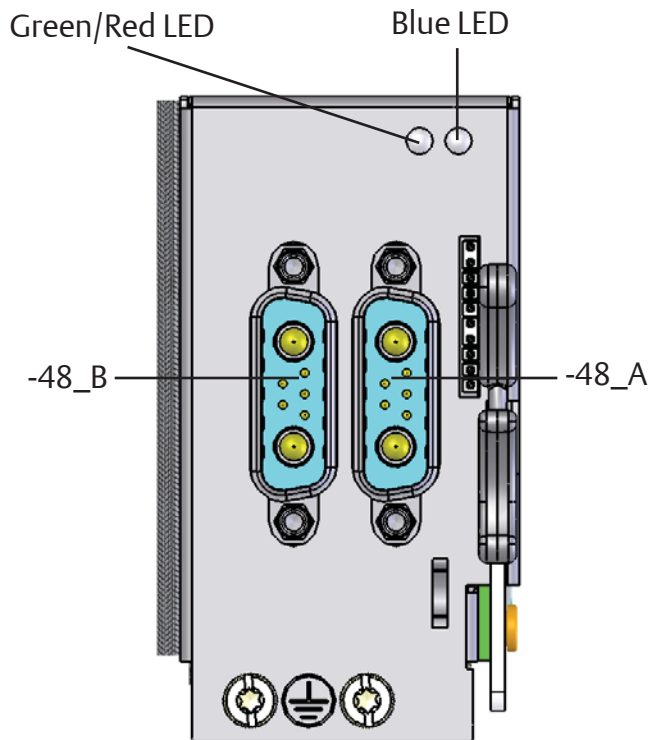

### Front Panel Drawing for AC-input unit

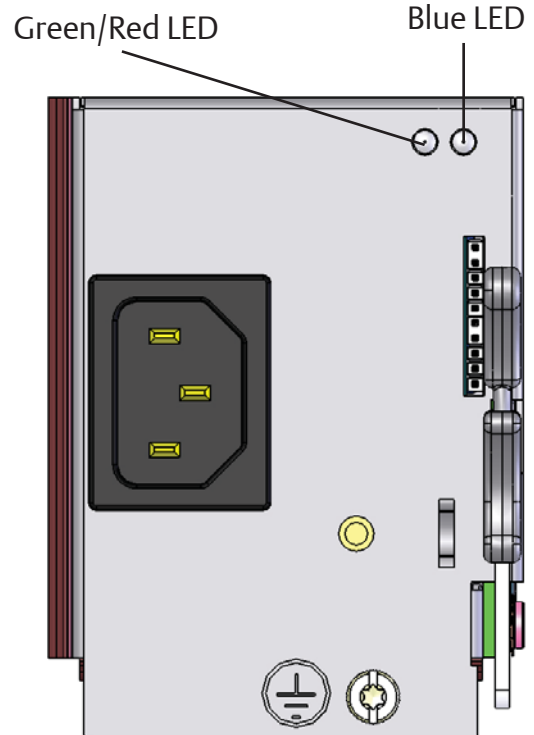

### General - MTC600-48

Weight: 25 oz. (700 grams) typical

### General - MTC600-AC

Weight: 30 oz. (850 grams) typical



## Mechanical Specifications (continued)

### Output Connector

Output Connector:

EPT P/N 501-50096-183,  
Tyco P/N 1469922-1,  
or equivalent

Mating Connector:

EPT P/N 502-50096-183,  
Tyco P/N 1469920-1,  
or equivalent

### Pinout

P1	PP_M1(2nd Mate)	PP_1(2nd Mate)	P13
P2	PP_CU1(2nd Mate)	PP_2(2nd Mate)	P14
P3	PP_CU2(2nd Mate)	PP_3(2nd Mate)	P15
P4	GND(1st Mate)	PP_4(2nd Mate)	P16
P5	GND(1st Mate)	PP_5(2nd Mate)	P17
P6	GND(1st Mate)	PP_6(2nd Mate)	P18
P7	GND(1st Mate)	PP_7(2nd Mate)	P19
P8	GND(1st Mate)	PP_8(2nd Mate)	P20
P9	GND(1st Mate)	PP_9(2nd Mate)	P21
P10	GND(1st Mate)	PP_10(2nd Mate)	P22
P11	GND(1st Mate)	PP_11(2nd Mate)	P23
P12	PP_M2(2nd Mate)	PP_12(2nd Mate)	P24

### Pin Description

PP_x	Payload Power (12V) for AMC/MCH/CU x
MP_x	Mgmt Power (3.3V) for AMC/MCH/CU x
GND	Output Return
PS_PM#	Last Mate Pin
GAx	Geographical address line x
PM_OK#	PM Present and OK [Output]
PMP_x#	PM x Present and OK [Input]
RST_PM_IN#	Resets PM EMMC [Input]
RST_PM_x#	Reset signal from PM x [Output]
PWR_ON_Mx	Power-On signal from MCH x
PS1_x#	Detects Presence of AMC/MCH/CU x
EN_x#	Enables (E)MMC of AMC/MCH/CU x
SCL_x	I2C Clock Line for Bus x
SDA_x	I2C Date Line for Bus x

1	PS_PM# (Last Mate)	PM_OK# (3rd Mate)	PS1_M1# (3rd Mate)	PS1_CU1# (3rd Mate)	EN_M1# (3rd Mate)	EN_CU1# (3rd Mate)	MP_M1# (3rd Mate)	MP_CU1# (3rd Mate)
2	N/C	PMP_A# (3rd Mate)	PS1_2# (3rd Mate)	PS1_1# (3rd Mate)	EN_2# (3rd Mate)	EN_1# (3rd Mate)	MP_2# (3rd Mate)	MP_1# (3rd Mate)
3	N/C	PMP_B# (3rd Mate)	PS1_4# (3rd Mate)	PS1_3# (3rd Mate)	EN_4# (3rd Mate)	EN_3# (3rd Mate)	MP_4# (3rd Mate)	MP_3# (3rd Mate)
4	N/C	PMP_C# (3rd Mate)	PS1_6# (3rd Mate)	PS1_5# (3rd Mate)	EN_6# (3rd Mate)	EN_5# (3rd Mate)	MP_6# (3rd Mate)	MP_5# (3rd Mate)
5	N/C	RST_PM_IN# (3rd Mate)	PS1_8# (3rd Mate)	PS1_7# (3rd Mate)	EN_8# (3rd Mate)	EN_7# (3rd Mate)	MP_8# (3rd Mate)	MP_7# (3rd Mate)
6	N/C	RST_PM_A# (3rd Mate)	PS1_10# (3rd Mate)	PS1_9# (3rd Mate)	EN_10# (3rd Mate)	EN_9# (3rd Mate)	MP_10# (3rd Mate)	MP_9# (3rd Mate)
7	GA0 (3rd Mate)	RST_PM_B# (3rd Mate)	PS1_12# (3rd Mate)	PS1_11# (3rd Mate)	EN_12# (3rd Mate)	EN_11# (3rd Mate)	MP_12# (3rd Mate)	MP_11# (3rd Mate)
8	GA1 (3rd Mate)	RST_PM_C# (3rd Mate)	PS1_M2# (3rd Mate)	PS1_CU2# (3rd Mate)	EN_M2# (3rd Mate)	EN_CU2# (3rd Mate)	MP_M2# (3rd Mate)	MP_CU2# (3rd Mate)
9	GA2 (3rd Mate)	SMP (3rd Mate)	SCL_B (3rd Mate)	SDA_B (3rd Mate)	SCL_A (3rd Mate)	SDA_A (3rd Mate)	PWR_ON_M2 (3rd Mate)	PWR_ON_M2 (3rd Mate)
	<b>A</b>	<b>B</b>	<b>C</b>	<b>D</b>	<b>E</b>	<b>F</b>	<b>G</b>	<b>H</b>

## Mechanical Specifications

### MTC600-48

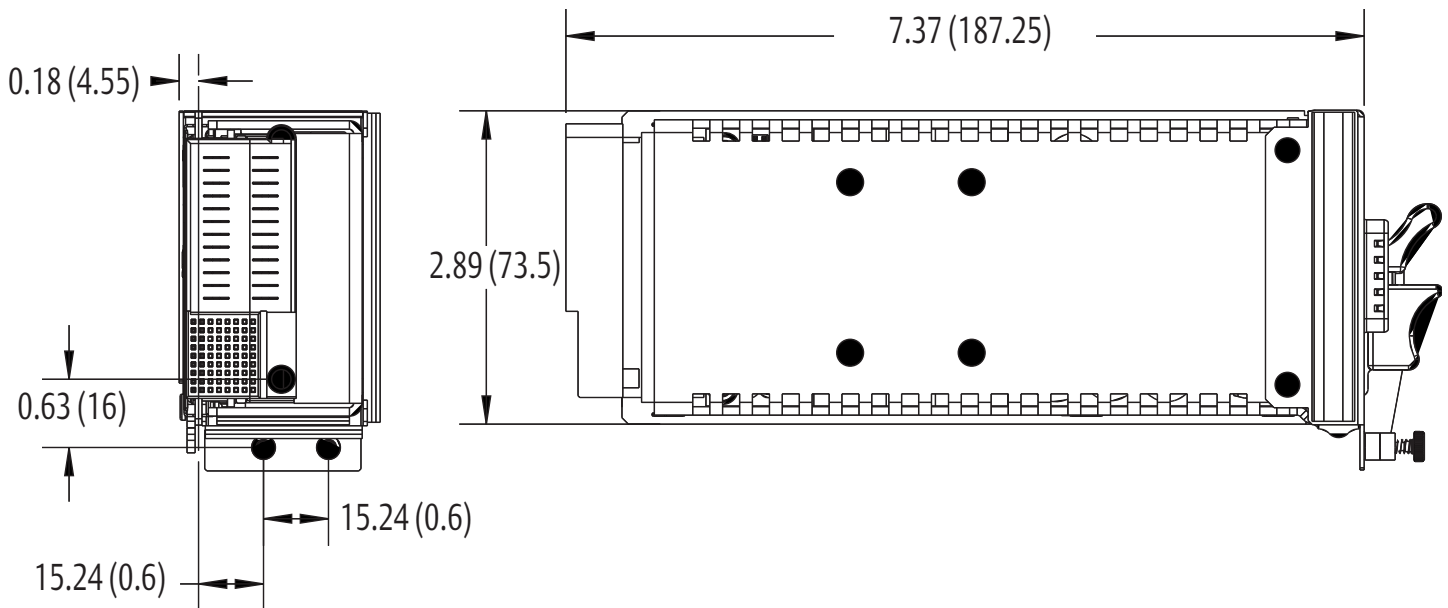

### MTC600-AC

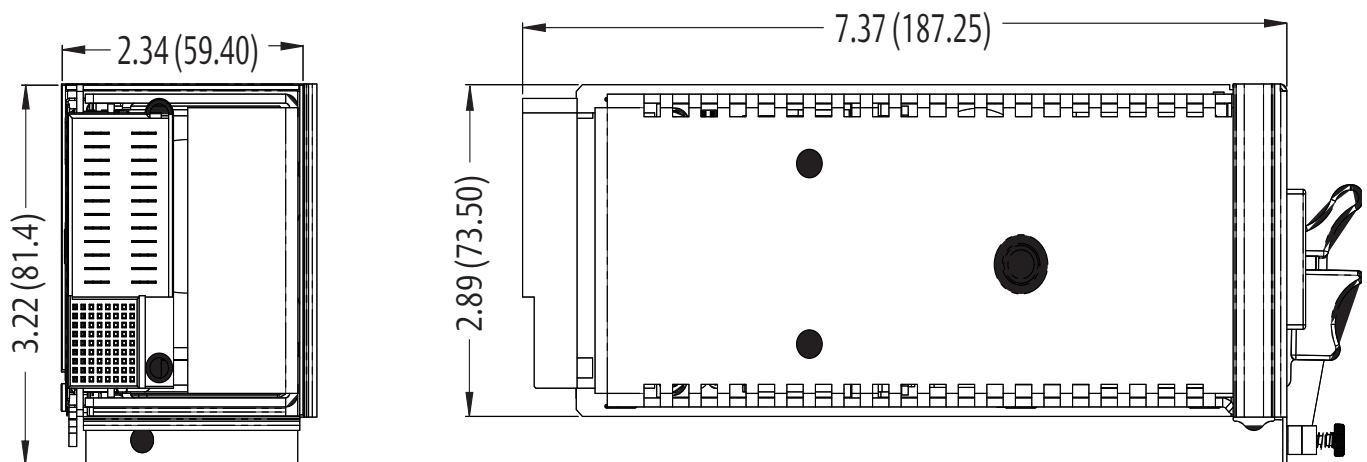

## Ordering Information

Power Level	Input Voltage	Redundant	Channel Count	Width	Height	Reserved
<b>MTC</b> <b>ppp</b> - <b>vv</b> <b>rr</b> <b>nn</b> <b>w</b> <b>h</b> <b>xx</b> <b>J</b>						
600 = 600 W	48 = -48 Vdc AC = 90-264 Vac	RR = Redundant Input and Redundant Output NR = Non- Redundant Input and Redundant Output	16 = 16ch	S = Single Width	9 = 9 HP 1 = 12 HP	For modified standards

MTC600-48RR16S9J  
600 W, -48 Vin, Redundant I/P, Redundant O/P, 16 channel, SW 9 HP

MTC600-ACNR16S1J  
600 W, AC-in, Non-Redundant I/P, Redundant O/P, 16 channel, SW 12 HP

### Americas

5810 Van Allen Way  
Carlsbad, CA 92008  
USA  
Telephone: +1 760 930 4600  
Facsimile: +1 760 930 0698

### Europe (UK)

Waterfront Business Park  
Merry Hill, Dudley  
West Midlands, DY5 1LX  
United Kingdom  
Telephone: +44 (0) 1384 842 211  
Facsimile: +44 (0) 1384 843 355

### Asia (HK)

16th - 17th Floors, Lu Plaza  
2 Wing Yip Street, Kwun Tong  
Kowloon, Hong Kong  
Telephone: +852 2176 3333  
Facsimile: +852 2176 3888

For global contact, visit:

[www.astecpower.com](http://www.astecpower.com)

[www.artesyn.com](http://www.artesyn.com)

[technicalsupport@astec.com](mailto:technicalsupport@astec.com)

[technicalsupport@artesyn.com](mailto:technicalsupport@artesyn.com)

While every precaution has been taken to ensure accuracy and completeness in this literature, Emerson Network Power assumes no responsibility, and disclaims all liability for damages resulting from use of this information or for any errors or omissions.

Printed in U.S.A.  
Issue SF3

**Emerson Network Power.**  
The global leader in enabling  
business-critical continuity.

- AC Power
- Connectivity
- DC Power
- **Embedded Power**
- Inbound Power
- Integrated Cabinet Solutions
- Outside Plant
- Precision Cooling
- Site Monitoring and Services

**EmersonNetworkPower.com**

Emerson Network Power and the Emerson Network Power logo are trademarks and service marks of Emerson Electric Co.  
©2006 Emerson Electric Co.

This is a Preliminary Datasheet. Emerson Network Power reserves the right to make changes to the information contained herein without notice and assumes no liability as a result of its use or application.