

Features

- Compact size: 6 mm diameter, 8 mm length
- Low capacitance and insertion loss
- Switch-Grade Fail-Short option available
- RoHS compliant*
-  UL Recognized

Applications

- Telecommunications equipment
- Industrial equipment/electronics
- Consumer electronics

2056 Series Light Duty 3-Electrode Gas Discharge Tube

Characteristics

Test Methods per ITU-T K.12 and IEC 61643-311.

Characteristic	Model No.				
	2056-09	2056-14	2056-20	2056-23	2056-25
DC Sparkover $\pm 20\%$ @ 100 V/s	90 V	145 V	200 V	230 V	250 V
Impulse Sparkover					
100 V/ μ s	< 750 V	< 750 V	< 600 V	< 600 V	< 600 V
1000 V/ μ s	< 850 V	< 850 V	< 700 V	< 700 V	< 700 V

Characteristic	Model No.				
	2056-35	2056-40	2056-42	2056-47	2056-60
DC Sparkover $\pm 20\%$ @ 100 V/s	350 V	400 V	420 V	470 V	600 V
Impulse Sparkover					
100 V/ μ s	< 650 V	< 700 V	< 700 V	< 800 V	< 900 V
1000 V/ μ s	< 750 V	< 800 V	< 800 V	< 900 V	< 1000 V

Insulation Resistance (IR) NOTE 1	50 / 100 / 250 Vdc	> 1 G Ω
Glow Voltage	10 mA	~ 70 V
Arc Voltage	1 A	~ 10 V
Glow-Arc Transition Current		< 1 A
Maximum Capacitance	1 MHz	< 2 pF
Maximum Impulse Discharge Current	5,000 A, 8/20 μ s	10 operations
Nominal Alternating Discharge Current	5 A, 50 Hz, 1 second	1 operation
Impulse Life	200 A 10/1000 μ s	100 operations
DC Holdover Voltage NOTE 2		< 150 ms
Operating Temperature		-30 to +85 °C
Storage Temperature		-40 to +115 °C
Climatic Category (IEC 60068-1)		40 / 90 / 21

Notes:

- UL Recognized component, UL File E153537.
- At delivery AQL 0.65, level II DIN ISO 2859
- Line to Line voltage is approximately 1.8 to 2 times the stated Line to Ground voltage.
- Discharge current rating is total current equally divided between Each Line To Ground (ELTG).

Note 1:	<u>DC Sparkover Voltage</u>	<u>IR Measuring Voltage</u>
	90 V	50 V
	145–400 V	100 V
	420–600 V	250 V

Note 2:	<u>Network Applied</u>	<u>DC Holdover Voltage</u>
	90–145 V	52 V
	200–250 V	135 V
	350–600 V	150 V

*RoHS Directive 2002/95/EC Jan. 27, 2003 including annex and RoHS Recast 2011/65/EU June 8, 2011.
 Specifications are subject to change without notice.
 Customers should verify actual device performance in their specific applications.

2056 Series Light Duty 3-Electrode Gas Discharge Tube

BOURNS®

Product Dimensions

2056-xx-A

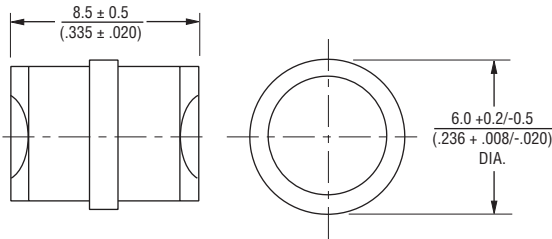

2056-xx-B3 0.8 mm dia., 3.8 mm spacing

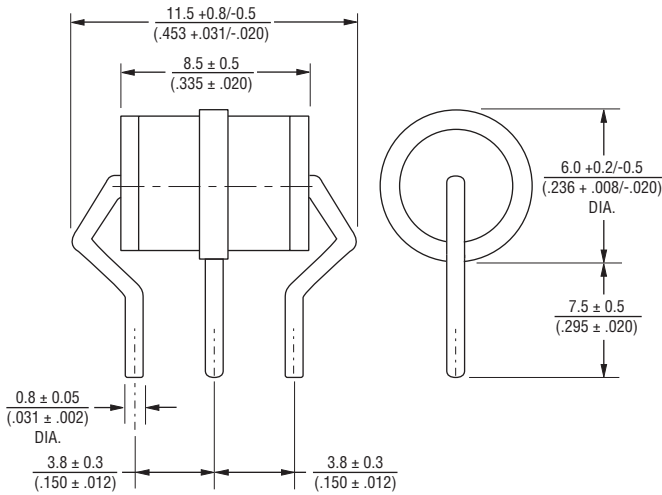

2056-xx-B2 0.8 mm dia., 4.4 mm spacing (B2FLF Switch-Grade Fail-Short Configuration Shown)

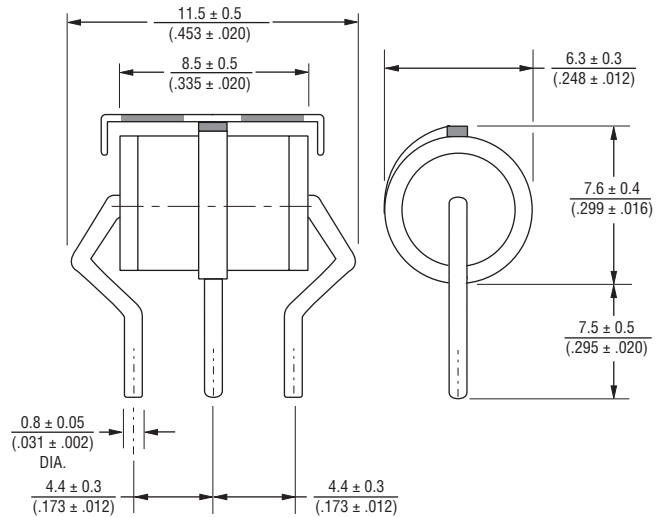

DIMENSIONS: $\frac{\text{MM}}{\text{(INCHES)}}$

How to Order

2056 - xx - xx (F) LF

Model Number Designator _____

Voltage (Divided by 10) _____

09 = 90 V	35 = 350 V
14 = 145 V	40 = 400 V
20 = 200 V	42 = 420 V
23 = 230 V	47 = 470 V
25 = 250 V	60 = 600 V

Leads _____

A = No leads/Cassette Applications
 B2 = 0.8 mm dia., 4.4 mm spacing
 B3 = 0.8 mm dia., 3.8 mm spacing

Switch-Grade Fail-Short Option _____

(Blank) = None
 F = Fail-Short Device (Optional)

RoHS Compliancy _____

LF = RoHS Compliant Product

Packaging Specifications

Model 2056 ships standard bulk pack, 100 pieces per tray; 5 trays per box, 2 boxes per outer pack (1K units).

BOURNS®

Asia-Pacific: Tel: +886-2 2562-4117 • Fax: +886-2 2562-4116

Europe: Tel: +41-41 768 5555 • Fax: +41-41 768 5510

The Americas: Tel: +1-951 781-5500 • Fax: +1-951 781-5700

www.bourns.com

REV. A 06/12

Specifications are subject to change without notice.
 Customers should verify actual device performance in their specific applications.