



# SDAS-01 series

## 1.5 To 15 Amp AC Current Sensor

- Zero insertion loss
- Inductive coupling to power line
- Choice of modes
  - Adjustable overcurrent sensor
  - Adjustable undercurrent sensor
- Solid state sensing circuit
- 1 Form C (SPDT) or 2 Form C (DPDT) internal relay

### Sensing Modes

**Overcurrent sensor** – Detects a current in excess of the value determined by the potentiometer setting. A built-in time delay, 200 ms, minimum, allows for normal starting and surge currents. Actual time delay is dependent upon potentiometer setting and magnitude of overcurrent. Any overcurrent lasting longer than this causes the internal relay of the SDAS-01 to energize. The relay will remain energized until sensor control voltage is removed, even if the overcurrent ceases to exist.

**Undercurrent sensor** – Reacts to a complete loss of sense current, or any current of less than the potentiometer setting. Upon application of sensor control voltage, there is a nominal 350ms delay during which time power line current must begin. This delay gives line components time to turn on. If, at the end of the delay, sense current should decrease to less than the potentiometer setting of the SDAS-01 and remain there for approximately 350 ms, the internal relay of the SDAS-01 will energize. It will remain energized until either sense control current again exceeds the potentiometer setting, or until sensor control voltage is removed.

### Engineering Data

**Control Voltage:** 24VAC 50/60 Hz /DC  $\pm$  10%.

**Sense-Current Range:** 1.5 to 15 amps AC.

**Internal Relay Contact Data:**

1 Form C (SPDT) type (code X1): 5A @ 28VDC or 2.5A @ 120VAC, res.

2 Form C (DPDT) type (code Y2): 2A @ 28VDC or 1A @ 120VAC, res.

**Set Point Variation:**  $\pm$ 25% over operating temperature range.

**Time Delay:**

**Overcurrent sensor:** 200 ms, min., after beginning of overcurrent. Actual delay is dependent upon potentiometer setting and magnitude of overcurrent (see Figure 1).

**Undercurrent sensor:** 350 ms, typ.; 200 ms, min., from beginning of undercurrent after control voltage is applied.

**Power Requirement:** 1.7W or 1.7VA @ 24VAC.

**Temperature Range:** **Storage:** -40°C to +85°C.

**Operating:** -25°C to +70°C.

**Enclosure:** Plastic dust cover.

**Mounting:** Socket. For sockets see KUP 3 pole sockets.

**Weight:** 3.17 oz. (90g) approximately.

Figure 1 – Typical Overcurrent Time Delay Curves

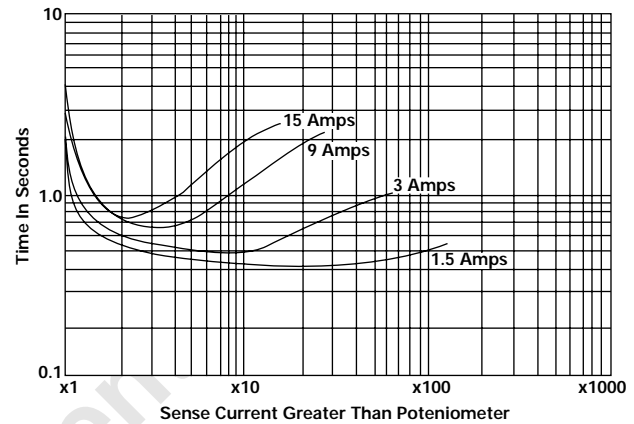

### Ordering Information – Boldface items are stocked.

**Undercurrent Sensors**

Part Number	Contacts	Mounting
<b>SDAS-01-7Y2S1024</b>	DPDT, 2A DC/1A AC	Socket
SDAS-01-7X1S1024	SPDT, 5A DC/2.5A AC	Socket

**Overcurrent Sensors**

Part Number	Contacts	Mounting
<b>SDAS-01-8Y2S1024</b>	DPDT, 2A DC/1A AC	Socket

### Outline Dimensions

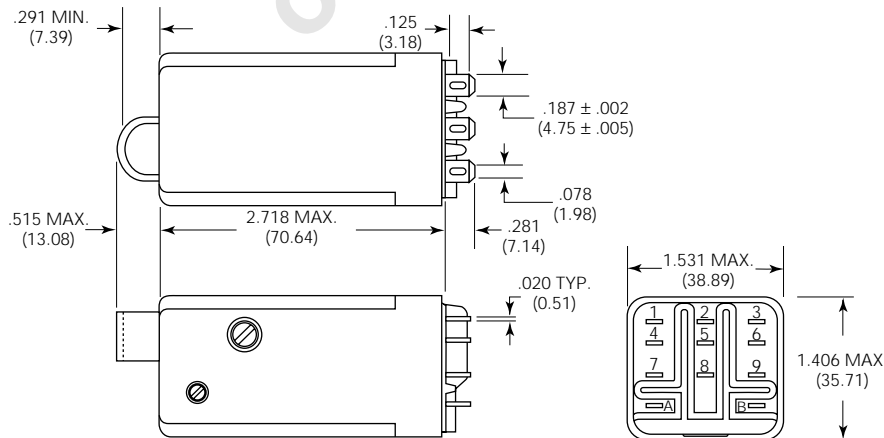

### Wiring Diagrams – Bottom Views

**1 Form C**

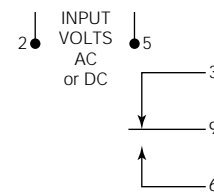

**2 Form C**

