

SERIES

PTHFxxxxR
PTKMxxxxR
PTHF
PTKM



Toroidal Power Chokes



Actual Size

Horizontal or Vertical Mounting

Excellent electromagnetic shielding

Applications Use Series PTHF for high DC saturation applications; use Series PTKM for low AC core loss applications.

DC Resistance at 25°C

Rated Idc based upon 40°C maximum rise from 90°C ambient with 0 Arms

Self Leads Solder coated along entire length

Mounting Toroids can be provided in a vertical or horizontal mount style. Suffix Part Number with "H" for horizontal mount.

dl Incremental Current is the value indicated in the table that will cause an approximate percentage drop in inductance

Marking DELEVAN and part number.

Example: PTHF50R-121
 DELEVAN PTHF50R-121

Physical Parameters on Next Page

*Complete part # must include series # PLUS the dash #
 For surface finish information, refer to www.delevanfinishes.com

PART NUMBER*	INDUCTANCE (μH) @ 1 kHz ±10%	RATED IDC (AMPS)	ΔL 10% dl ADC	ΔL 20% dl ADC	DC RESISTANCE MAXIMUM (OHMS)	SRF MINIMUM (MHz)
SERIES PTHF HIGH SATURATION CORE						
PTHF10-50	10	7.36	6.0	8.7	0.010	35.0
PTHF25-50	25	5.20	3.6	5.3	0.020	10.0
PTHF50-50	50	3.93	2.0	3.1	0.035	7.0
PTHF75-50	75	3.47	1.6	2.5	0.045	5.0
PTHF100-50	100	3.14	1.5	2.2	0.055	4.0
PTHF150-50	150	2.33	1.2	1.8	0.100	2.0
PTHF200-50	200	1.97	1.0	1.6	0.140	1.7
PTHF250-50	250	1.84	0.9	1.4	0.160	1.5
PTHF330-50	330	1.69	0.8	1.2	0.190	1.0
PTHF10-121	10	8.27	9.0	14.0	0.010	20.0
PTHF25-121	25	6.34	7.0	10.5	0.017	8.0
PTHF50-121	50	4.77	3.9	6.0	0.030	4.0
PTHF75-121	75	3.90	3.9	5.8	0.045	3.0
PTHF100-121	100	3.24	3.4	4.7	0.065	2.0
PTHF150-121	150	2.68	3.3	4.8	0.095	1.5
PTHF250-121	250	2.07	2.2	3.2	0.160	1.0
PTHF10-59	10	14.50	15.0	20.0	0.008	20.0
PTHF25-59	25	9.80	11.0	16.0	0.011	8.0
PTHF50-59	50	6.90	8.3	12.0	0.022	4.0
PTHF75-59	75	5.90	6.7	9.1	0.030	3.0
PTHF100-59	100	4.90	6.5	8.2	0.044	2.0
PTHF150-59	150	4.50	4.2	6.0	0.052	1.0
PTHF250-59	250	3.50	4.0	5.6	0.088	1.0
PTHF500-59	500	2.60	2.7	3.8	0.160	0.8
PTHF750-59	750	2.10	1.8	2.7	0.240	0.6
PTHF25-894	25	12.80	13.5	20.0	0.008	8.0
PTHF50-894	50	9.90	10.8	15.2	0.016	4.0
PTHF75-894	75	8.00	8.0	12.0	0.023	3.0
PTHF100-894	100	8.00	7.1	10.6	0.023	2.0
PTHF150-894	150	6.50	6.0	9.0	0.035	1.0
PTHF250-894	250	5.00	4.6	6.8	0.060	1.0
PTHF500-894	500	3.40	3.1	4.6	0.131	0.8
PTHF750-894	750	3.00	2.7	4.0	0.160	0.6
PTHF1000-894	1000	2.40	2.3	3.5	0.235	0.4
SERIES PTKM FERROUS ALLOY CORE						
PTKM10-50	10	7.36	1.70	3.30	0.010	35.0
PTKM25-50	25	5.20	1.00	1.90	0.020	10.0
PTKM50-50	50	3.93	0.70	1.30	0.035	7.0
PTKM75-50	75	3.47	0.60	1.10	0.045	5.0
PTKM100-50	100	3.14	0.50	0.96	0.055	4.0
PTKM150-50	150	2.33	0.40	0.78	0.100	2.0
PTKM200-50	200	1.97	0.35	0.65	0.140	1.7
PTKM250-50	250	1.84	0.31	0.59	0.160	1.5
PTKM330-50	330	1.69	0.27	0.50	0.190	1.0
PTKM10-121	10	8.27	5.30	9.10	0.010	20.0
PTKM25-121	25	6.34	3.30	5.70	0.017	8.0
PTKM50-121	50	4.77	2.30	4.00	0.030	4.0
PTKM75-121	75	3.90	1.80	3.10	0.045	3.0
PTKM100-121	100	3.24	1.60	2.80	0.065	2.0
PTKM150-121	150	2.68	1.30	2.20	0.095	1.5
PTKM250-121	250	2.07	0.90	1.70	0.160	1.0
PTKM10-59	10	14.50	7.60	13.00	0.008	20.0
PTKM25-59	25	9.80	4.70	8.30	0.011	8.0
PTKM50-59	50	6.90	3.30	5.70	0.022	4.0
PTKM75-59	75	5.90	3.00	4.90	0.030	3.0
PTKM100-59	100	4.90	2.40	4.20	0.044	2.0
PTKM150-59	150	4.50	1.90	3.40	0.052	1.0
PTKM250-59	250	3.50	1.50	2.70	0.088	1.0
PTKM500-59	500	2.60	1.10	1.80	0.160	0.8
PTKM750-59	750	2.10	0.90	1.60	0.240	0.6
PTKM25-894	25	12.80	6.60	11.00	0.008	8.0
PTKM50-894	50	9.90	4.20	7.40	0.016	4.0
PTKM75-894	75	8.00	3.70	6.40	0.023	3.0
PTKM100-894	100	8.00	3.50	6.00	0.023	2.0
PTKM150-894	150	6.50	2.30	4.30	0.035	1.0
PTKM250-894	250	5.00	1.90	3.20	0.060	1.0
PTKM500-894	500	3.40	1.40	2.50	0.131	0.8
PTKM750-894	750	3.00	1.20	2.10	0.160	0.6
PTKM1000-894	1000	2.40	1.00	1.80	0.235	0.4



SERIES

PTHFxxxxR & PTKMxxxxR
PTHF & PTKM

RoHS
Compliant

Traditional
First Quality

Toroidal Power Chokes – Horizontal or Vertical Mount

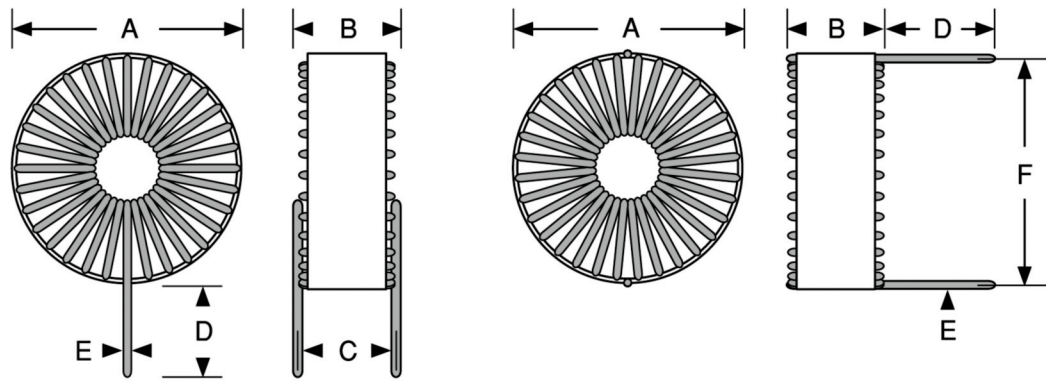

Vertical Configuration

Horizontal Configuration

PHYSICAL PARAMETERS

* **Nominal Dimensions** Allow up to 10% of nominal for maximum size

** **Part Number** Insert HF of KM for complete part number, and suffix "H" for horizontal mounting

Electrical Information on Preceding Page

PART NUMBER	A Nominal*		B Nominal*		C Typical		D Nominal*		E Nominal*		F Nominal*	
	Inches	mm	Inches	mm	Inches	mm	Inches	mm	Inches	mm	Inches	mm
PT**10-50	0.625	15.88	0.300	7.62	0.250	6.35	0.500	12.70	0.036	0.91	0.600	15.24
PT**25-50	0.625	15.88	0.300	7.62	0.250	6.35	0.500	12.70	0.032	0.81	0.600	15.24
PT**50-50	0.625	15.87	0.300	7.62	0.250	6.35	0.500	12.70	0.028	0.71	0.600	15.24
PT**75-50	0.625	15.87	0.300	7.62	0.250	6.35	0.500	12.70	0.025	0.63	0.600	15.24
PT**100-50	0.625	15.87	0.300	7.62	0.250	6.35	0.500	12.70	0.025	0.63	0.600	15.24
PT**150-50	0.625	15.87	0.300	7.62	0.250	6.35	0.500	12.70	0.020	0.51	0.600	15.24
PT**200-50	0.625	15.87	0.300	7.62	0.250	6.35	0.500	12.70	0.018	0.46	0.600	15.24
PT**250-50	0.625	15.87	0.300	7.62	0.250	6.35	0.500	12.70	0.018	0.46	0.600	15.24
PT**330-50	0.625	15.87	0.300	7.62	0.250	6.35	0.500	12.70	0.018	0.46	0.600	15.24
PT**10-121	0.820	20.83	0.400	10.16	0.320	8.13	0.500	12.70	0.040	1.02	0.780	19.81
PT**25-121	0.820	20.83	0.400	10.16	0.320	8.13	0.500	12.70	0.040	1.02	0.780	19.81
PT**50-121	0.820	20.83	0.400	10.16	0.320	8.13	0.500	12.70	0.036	0.91	0.780	19.81
PT**75-121	0.820	20.83	0.400	10.16	0.320	8.13	0.500	12.70	0.032	0.81	0.780	19.81
PT**100-121	0.820	20.83	0.400	10.16	0.320	8.13	0.500	12.70	0.028	0.71	0.780	19.81
PT**150-121	0.850	21.59	0.400	10.16	0.320	8.13	0.500	12.70	0.025	0.63	0.780	19.81
PT**250-121	0.850	21.59	0.400	10.16	0.320	8.13	0.500	12.70	0.023	0.58	0.780	19.81
PT**10-59	1.100	27.94	0.475	12.06	0.370	9.40	0.500	12.70	0.051	1.30	1.050	26.67
PT**25-59	1.100	27.94	0.475	12.06	0.370	9.40	0.500	12.70	0.051	1.30	1.050	26.67
PT**50-59	1.100	27.94	0.475	12.06	0.370	9.40	0.500	12.70	0.045	1.14	1.050	26.67
PT**75-59	1.100	27.94	0.475	12.06	0.370	9.40	0.500	12.70	0.040	1.02	1.050	26.67
PT**100-59	1.100	27.94	0.475	12.06	0.370	9.40	0.500	12.70	0.036	0.91	1.050	26.67
PT**150-59	1.100	27.94	0.475	12.06	0.450	11.43	0.500	12.70	0.036	0.91	1.050	26.67
PT**250-59	1.150	29.21	0.475	12.06	0.450	11.43	0.500	12.70	0.032	0.81	1.050	26.67
PT**500-59	1.150	29.21	0.475	12.06	0.450	11.43	0.500	12.70	0.028	0.71	1.050	26.67
PT**750-59	1.150	29.21	0.475	12.06	0.450	11.43	0.500	12.70	0.025	0.63	1.050	26.67
PT**25-894	1.300	33.02	0.650	16.51	0.600	15.24	0.750	19.05	0.064	1.3	1.250	31.75
PT**50-894	1.300	33.02	0.650	16.51	0.600	15.24	0.750	19.05	0.051	1.30	1.250	31.75
PT**75-894	1.300	33.02	0.650	16.51	0.600	15.24	0.750	19.05	0.051	1.30	1.250	31.75
PT**100-894	1.300	33.02	0.650	16.51	0.600	15.24	0.750	19.05	0.051	1.30	1.250	31.75
PT**150-894	1.300	33.02	0.650	16.51	0.600	15.24	0.750	19.05	0.045	1.14	1.250	31.75
PT**250-894	1.300	33.02	0.650	16.51	0.600	15.24	0.750	19.05	0.040	1.02	1.250	31.75
PT**500-894	1.300	33.02	0.650	16.51	0.600	15.24	0.750	19.05	0.032	0.81	1.250	31.75
PT**750-894	1.300	33.02	0.650	16.51	0.600	15.24	0.750	19.05	0.032	0.81	1.250	31.75
PT**1000-894	1.300	33.02	0.650	16.51	0.600	15.24	0.750	19.05	0.028	0.71	1.250	31.75

