

Kyocera's series of Multilayer Ceramic Chip Capacitors are designed to meet a wide variety of needs. We offer a complete range of products for both general and specialized applications, including general-purpose CM series, high-voltage CF series, low profile CT series, and DM series for automotive uses.

## Features

- We have factories worldwide in order to supply our global customer bases quickly and efficiently and to maintain our reputation as one of the highest-volume producers in the industry.
- All our products are highly reliable due to their monolithic structure of high-purity and superfine uniform ceramics and their integral internal electrodes.
- By combining superior manufacturing technology and materials with high dielectric constants, we produce extremely compact components with exceptional specifications.
- Our stringent quality control in every phase of production from material procurement to shipping ensures consistent manufacturing and super quality.
- Kyocera components are available in a wide choice of dimensions, temperature characteristics, rated voltages, and terminations to meet specific configurational requirements.

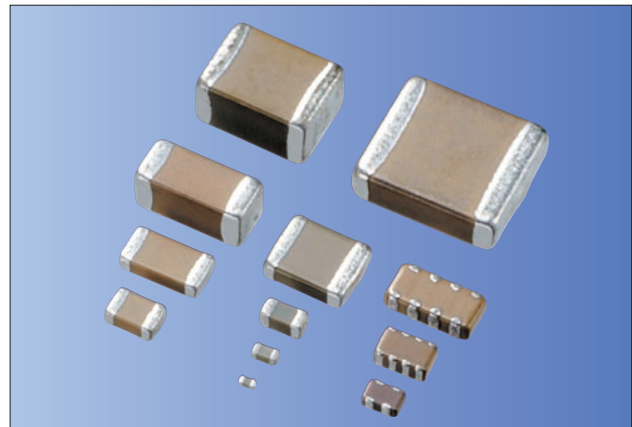

Pb Free

RoHS Compliant

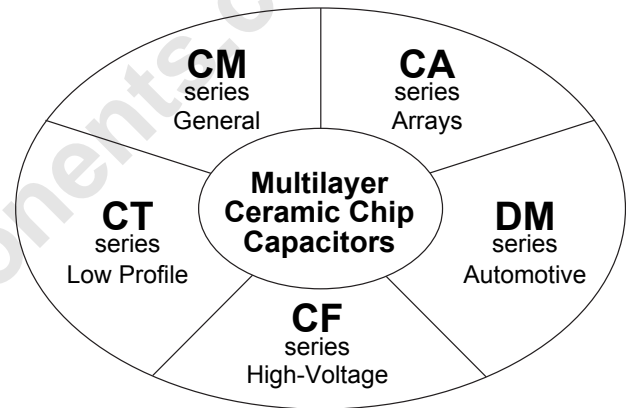

## Structure

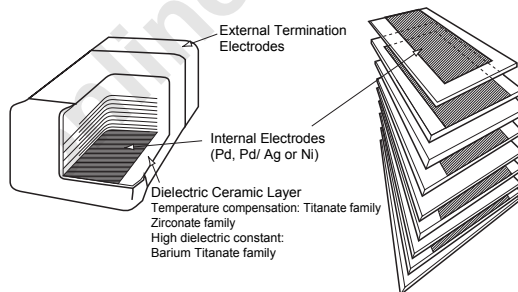

Nickel Barrier Termination Products

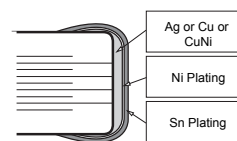

## Tape and Reel



## Bulk Cassette

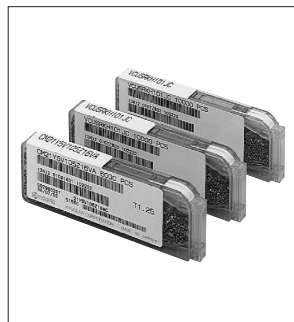

Please contact your local AVX, Kyocera sales office or distributor for specifications not covered in this catalog.

Our products are continually being improved. As a result, the capacitance range of each series is subject to change without notice. Please contact a sales representative to confirm compatibility with your application.

Kyocera Ceramic Chip Capacitors are available for different applications as classified below:

Series	Dielectric Options	Typical Applications	Features	Terminations	Available Size
CM	C0G (NP0) X5R X7R *X6S *X7S Y5V	General Purpose	Wide Cap Range	Nickel Barrier	0201, 0402, 0603 0805, 1206, 1210 1812
CF	C0G (NP0) X7R	High Voltage & Power Circuits	High Voltage 250VDC, 630VDC 1000VDC, 2000VDC 3000VDC, 4000VDC	Nickel Barrier	0805, 1206, 1210 1812, 2208, 1808 2220
CT	C0G (NP0) X5R X7R Y5V	PLCC (Decoupling)	Low Profile	Nickel Barrier	0402, 0603, 0805 1206, 1210
DM	X7R	Automotive	Thermal shock Resistivity High Reliability	Nickel Barrier	0603, 0805, 1206
CA	C0G (NP0) X5R, X7R	Digital Signal Pass line	Reduction in Placing Costs	Nickel Barrier	0405, 0508

\* option

onlinecomponents.com

## Dimensions

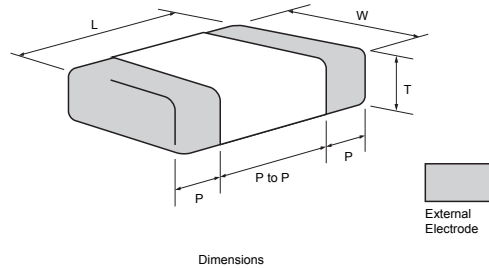

## Tape & Reel

Size	EIA CODE	JIS CODE	Dimensions (mm)					
			L	W	P min.	P max.	P to P min.	T max.
03	0201	0603	0.6±0.03	0.3±0.03	0.13	0.23	0.20	0.33
05	0402	1005	1.0±0.05	0.5±0.05	0.15	0.35	0.30	0.55
105	0603	1608	1.6±0.10	0.8±0.10	0.20	0.60	0.50	0.90
21	0805	2012	2.0±0.10	1.25±0.10	0.20	0.75	0.70	1.35
316	1206	3216	3.2±0.20	1.60±0.15	0.30	0.85	1.40	1.75
32	1210	3225	3.2±0.20	2.50±0.20	0.30	1.00	1.40	2.70
42	1808	4520	4.5±0.20	2.00±0.20	0.15	0.85	2.60	2.20
43	1812	4532	4.5±0.30	3.20±0.20	0.30	1.10	2.00	3.00
52	2208	5720	5.7±0.40	2.00±0.20	0.15	0.85	4.20	2.20
55	2220	5750	5.7±0.40	5.00±0.40	0.30	1.40	2.50	2.70

- T (Thickness) depends on capacitance value. Standard thickness is shown on the appropriate product pages.
- CA series (please refer applicable page)
- As for the size of the product specified individually, please contact us.

## Bulk Cassette

Size	EIA CODE	JIS CODE	L	W	T	P		P to P
						min.	max.	min.
05	0402	1005	1.0±0.05	0.5±0.05	0.5±0.05	0.15	0.35	0.30
105	0603	1608	1.6±0.07	0.8±0.07	0.8±0.07	0.20	0.60	0.50
21	0805	2012	2.0±0.1	1.25±0.1	1.25±0.1	0.20	0.75	0.70

Note) Regarding support for Bulk cases, please contact us for further information.

# Multilayer Ceramic Chip Capacitors Ordering Information



onlinecomponents.com

THE ONLINE DISTRIBUTOR OF ELECTRONIC COMPONENTS

## KYOCERA PART NUMBER:

CM 21 X7R 104 K 50 A T □□□

### SERIES CODE

CM = General Purpose      CA = Capacitor Arrays  
 CF = High Voltage  
 CT = Low Profile  
 DM = Automotive

### SIZE CODE

SIZE	EIA (JIS)	SIZE	EIA (JIS)	SIZE	EIA (JIS)
03	= 0201 (0603)	21	= 0805 (2012)	52	= 2208 (5720)
05	= 0402 (1005)	316	= 1206 (3216)	55	= 2220 (5750)
105	= 0603 (1608)	32	= 1210 (3225)	D11	= 0405 (1012)/ 2cap
F12	= 0508 (1220)/ 4cap	42	= 1808 (4520)	D12	= 0508 (1220)/ 2cap
		43	= 1812 (4532)		

### DIELECTRIC CODE

CODE	EIA CODE		
CG	= C0G (NPO)	X7S	= X7S (Option)
X5R	= X5R	X6S	= X6S (Option)
X7R	= X7R	Y5V	= Y5V

Negative dielectric types are available on request.

### CAPACITANCE CODE

Capacitance expressed in pF. 2 significant digits plus number of zeros.

For Values < 10pF, Letter R denotes decimal point,

eg. 100000pF = 104      1.5pF = 1R5  
 0.1μF = 104      0.5pF = R50  
 4700pF = 472      100μF = 107

### TOLERANCE CODE

A = ±0.05pF (option)	D = ±0.5pF	J = ±5%	Z = -20 to +80%
B = ±0.1pF (option)	F = ±1pF	K = ±10%	
C = ±0.25pF	G = ±2% (option)	M = ±20%	

### VOLTAGE CODE

04 = 4VDC	100 = 100VDC	1000 = 1000VDC
06 = 6.3VDC	250 = 250VDC	2000 = 2000VDC
10 = 10VDC	400 = 400VDC	3000 = 3000VDC
16 = 16VDC	630 = 630VDC	4000 = 4000VDC
25 = 25VDC		
35 = 35VDC		
50 = 50VDC		

### TERMINATION CODE

A = Nickel Barrier

### PACKAGING CODE

B = Bulk	L = 13" Reel Taping & 4mm Cavity pitch
C = Bulk Cassette (option)	H = 7" Reel Taping & 2mm Cavity pitch
T = 7" Reel Taping & 4mm Cavity pitch	N = 13" Reel Taping & 2mm Cavity pitch

### OPTION

Thickness max. value is indicated in CT series

EX. 125 → 1.25mm max.  
 095 → 0.95mm max.

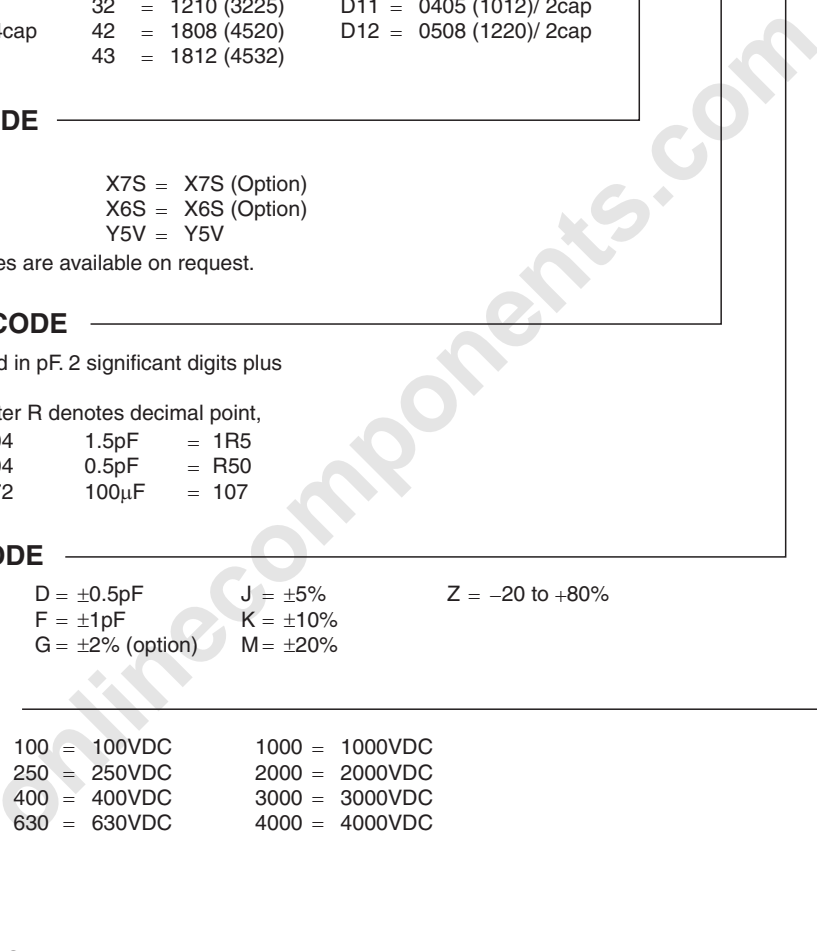

### High Dielectric Constant

EIA Dielectric	Temperature Range	$\Delta C$ max.
X5R	-55 to 85°C	±15%
X7R	-55 to 125°C	
*X7S	-55 to 125°C	±22%
*X6S	-55 to 105°C	
Y5V	-30 to 85°C	-82 to +22%

\* option

### Temperature Compensation Type

Electric Code Value (pF)	COG	U $\Delta$ N750	SL +350 to -1000
0.5 to 2.7	CK	UK	SL
3.0 to 3.9	CJ	UJ	SL
4.0 to 9.0	CH	UJ	SL
≥10	CG	UJ	SL

K = ±250ppm/°C, J = ±120ppm/°C, H = ±60ppm/°C, G = ±30ppm/°C  
e.g. CG = 0±30ppm/°C

Note: All parts will be marked as "CG" but will conform to the above table.

### Available Tolerances

Dielectric materials, capacitance values and tolerances are available in the following combinations only:

EIA Dielectric	Tolerance	Capacitance
COG	C=±0.25pF	*1 <10pF
	D=±0.50pF	
	F=±1pF	
	*3 A=±0.05pF	<0.5pF
	B=±0.1pF	≤5pF
X5R X6R X7R	*3 G=±2%	≥10pF
	J=±5%	E12 Series
	K=±10%	
X5R X6R X7R	*2 K=±10%	E6 Series
X7R	M=±20%	
Y5V	Z=-20% to +80%	E3 Series

Note:

\*1 Nominal values below 10pF are available in the standard values of 0.5pF, 1.0pF, 1.5pF, 2.0pF, 3.0pF, 4.0pF, 5.0pF, 6.0pF, 7.0pF, 8.0pF, 9.0pF

\*2 J = ±5% for X7R (X5R) is available on request.

\*3 option

### E Standard Number

E3	E6	E12	E24 (Option)	
1.0	1.0	1.0	1.0	1.1
		1.2	1.2	1.3
	1.5	1.5	1.5	1.6
		1.8	1.8	2.0
2.2	2.2	2.2	2.2	2.4
		2.7	2.7	3.0
	3.3	3.3	3.3	3.6
		3.9	3.9	4.3
4.7	4.7	4.7	4.7	5.1
		5.6	5.6	6.2
	6.8	6.8	6.8	7.5
		8.2	8.2	9.1

## Features

We offer a diverse product line ranging from ultra-compact (0.6×0.3mm) to large (4.3×3.2mm) components configured for a variety of temperature characteristics, rated voltages, and packages. We offer the choice and flexibility for almost any applications.

## Applications

This standard type is ideal for use in a wide range of applications, from commercial to industrial equipment.

## Temperature Compensation Dielectric

Size (EIA Code)	CM03 (0201)					CM05 (0402)			CM105 (0603)		CM21 (0805)			
	C <sub>Δ</sub>		U <sub>Δ</sub>		SL	C <sub>Δ</sub>	U <sub>Δ</sub>	SL	C <sub>Δ</sub>		C <sub>Δ</sub>			
Rated Voltage (VDC)	25	50	16	25	25	50	50	50	50	100	16	25	50	100
Capacitance (pF)														
R20	0.2													
R50	0.5													
1R0	1.0													
1R5	1.5													
	2.0													
	3.0													
	4.0													
	5.0													
	6.0													
	7.0													
	8.0													
	9.0													
100	10													
120	12													
	15													
	18													
	22													
	27													
	33													
	39													
	47													
	56													
	68													
	82													
	100													
101	120													
121	150													
	180													
	220													
	270													
	330													
	390													
	470													
	560													
	680													
	820													
102	1000													
122	1200													
	1500													
	1800													
	2200													
	2700													
	3300													
	3900													
	4700													
	5600													
	6800													
	8200													
103	10000													
123	12000													
	15000													
	18000													

## Thickness and standard package quantity

Size	*03	*05	105	*105	21, 316, 32									
Thickness (mm)	A	B	C	C	D	E	F	G	H	I	J	K	L	
	0.3±0.03	0.5±0.05	0.8±0.1	0.8±0.1	0.6±0.1	0.85±0.1	1.15±0.1	1.25±0.1	1.4 max.	1.6 max.	1.6±0.15	2.0±0.2	2.5±0.2	
Taping (180 dia reel)	15kp (P8)	10kp (P8)	4kp (P8)	8kp (P8)	4kp (P8)	4kp (P8)	3kp (E8)	3kp (E8)	3kp (E8)	2.5kp (E8)	2.5kp (E8)	2kp (E8)	1kp (E8)	
Taping (330 dia reel)	50kp (P8)	50kp (P8)	10kp (P8)	20kp (P8)	10kp (P8)	10kp (P8)	10kp (E8)	10kp (E8)	10kp (E8)	5kp (E8)	5kp (E8)	5kp (E8)	—	

Size	43			
Thickness (mm)	J	K	L	M
	1.6±0.15	2.0±0.2	2.5±0.2	2.8±0.2
Taping (180 dia reel)	1kp (E12)	1kp (E12)	0.5kp (E12)	0.5kp (E12)
Taping (330 dia reel)	—	—	—	—

Note: P8 = 8mm width paper tape  
E8 = 8mm width plastic tape  
E12 = 12mm width plastic tape

\* Carrier tape 2mm pitch from one capacitor to another.

X5R Dielectric

Size (EIA Code)	CM03 (0201)					CM05 (0402)						CM105 (0603)						CM21 (0805)					
	4	6.3	10	16	25	4	6.3	10	16	25	50	4	6.3	10	16	25	50	4	6.3	10	16	25	50
101 151					A																		
102 152			A	A						B	B												
103 153																							
104 154																							
105 155																							
106 156																							
476																							

Size (EIA Code)	CM316 (1206)					CM32 (1210)						CM43 (1812)	
	6.3	10	16	25	50	4	6.3	10	16	25	50	6.3	50
104 154					F								
105 155				J						H K L			L
106 156	J	J	J	J			L	K L	I L				
107												M	

Optional Spec.

Thickness and standard package quantity

Size	*03	*05	105	*105	21, 316, 32								
	A	B	C	C	D	E	F	G	H	I	J	K	L
Thickness (mm)	0.3±0.03	0.5±0.05	0.8±0.1	0.8±0.1	0.6±0.1	0.85±0.1	1.15±0.1	1.25±0.1	1.4 max.	1.6 max.	1.6±0.15	2.0±0.2	2.5±0.2
Taping (180 dia reel)	15kp (P8)	10kp (P8)	4kp (P8)	8kp (P8)	4kp (P8)	4kp (P8)	3kp (E8)	3kp (E8)	3kp (E8)	2.5kp (E8)	2.5kp (E8)	2kp (E8)	1kp (E8)
Taping (330 dia reel)	50kp (P8)	50kp (P8)	10kp (P8)	20kp (P8)	10kp (P8)	10kp (P8)	10kp (E8)	10kp (E8)	10kp (E8)	5kp (E8)	5kp (E8)	5kp (E8)	—

Size	43			
Thickness (mm)	J	K	L	M
	1.6±0.15	2.0±0.2	2.5±0.2	2.8±0.2
Taping (180 dia reel)	1kp (E12)	1kp (E12)	0.5kp (E12)	0.5kp (E12)
Taping (330 dia reel)	—	—	—	—

Note: P8 = 8mm width paper tape  
E8 = 8mm width plastic tape  
E12 = 12mm width plastic tape

\* Carrier tape 2mm pitch from one capacitor to another.

## X7R, Dielectric

Size (EIA Code)	CM03 (0201)			CM05 (0402)			CM105 (0603)					CM21 (0805)							
Rated Voltage (VDC)	10	16	25	16	25	50	6.3	10	16	25	50	100	6.3	10	16	25	50	100	
Capacitance (pF)																			
101 100																			
151 150		A	A																
220 220		A	A																
330 330		A	A																
470 470		A	A																
680 680		A	A																
102 1000		A	A																
152 1500	A																		
2200 2200	A																		
3300 3300	A																		
4700 4700	A																		
6800 6800	A																		
103 10000																			
153 15000																			
22000 22000																			
33000 33000																			
47000 47000																			
68000 68000																			
104 100000																			
154 150000																			
220000 220000																			
330000 330000																			
470000 470000																			
105 1000000																			
155 1500000																			
2200000 2200000																			
3300000 3300000																			
4700000 4700000																			
106 10000000																			

Size (EIA Code)	CM316 (1206)						CM32 (1210)				CM43 (1812)		
Rated Voltage (VDC)	6.3	10	16	25	50	100	10	16	25	50	100	50	100
Capacitance (pF)													
103 10000													
22000 22000													
47000 47000													
104 100000													
220000 220000													
470000 470000													
105 1000000													
2200000 2200000													
4700000 4700000													
106 10000000													
22000000 22000000													

Optional Spec.

## Y5V Dielectric

Size (EIA Code)	CM03 (0201)	CM05 (0402)			CM105 (0603)				CM21 (0805)				CM316 (1206)			CM32 (1210)					
Rated Voltage (VDC)	6.3	10	10	16	25	50	10	16	25	50	10	16	25	50	10	16	25	10	16	25	
Capacitance (pF)																					
102 1000																					
2200 2200		A																			
472 4700		A																			
103 10000	A																				
22000 22000																					
473 47000																					
104 100000																					
220000 220000																					
474 470000																					
105 1000000																					
2200000 2200000																					
475 4700000																					
106 10000000																					
22000000 22000000																					
476 47000000																					

## Thickness and standard package quantity

Size	*03	*05	105	*105	21, 316, 32								
Thickness (mm)	A	B	C	C	D	E	F	G	H	I	J	K	L
	0.3±0.03	0.5±0.05	0.8±0.1	0.8±0.1	0.6±0.1	0.85±0.1	1.15±0.1	1.25±0.1	1.4 max.	1.6 max.	1.6±0.15	2.0±0.2	2.5±0.2
Taping (180 dia reel)	15kp (P8)	10kp (P8)	4kp (P8)	8kp (P8)	4kp (P8)	4kp (P8)	3kp (E8)	3kp (E8)	3kp (E8)	2.5kp (E8)	2.5kp (E8)	2kp (E8)	1kp (E8)
Taping (330 dia reel)	50kp (P8)	50kp (P8)	10kp (P8)	20kp (P8)	10kp (P8)	10kp (P8)	10kp (E8)	10kp (E8)	10kp (E8)	5kp (E8)	5kp (E8)	5kp (E8)	—

Size	43			
Thickness (mm)	J	K	L	M
	1.6±0.15	2.0±0.2	2.5±0.2	2.8±0.2
Taping (180 dia reel)	1kp (E12)	1kp (E12)	0.5kp (E12)	0.5kp (E12)
Taping (330 dia reel)	—	—	—	—

Note: P8 = 8mm width paper tape  
E8 = 8mm width plastic tape  
E12 = 12mm width plastic tape

\* Carrier tape 2mm pitch from one capacitor to another.



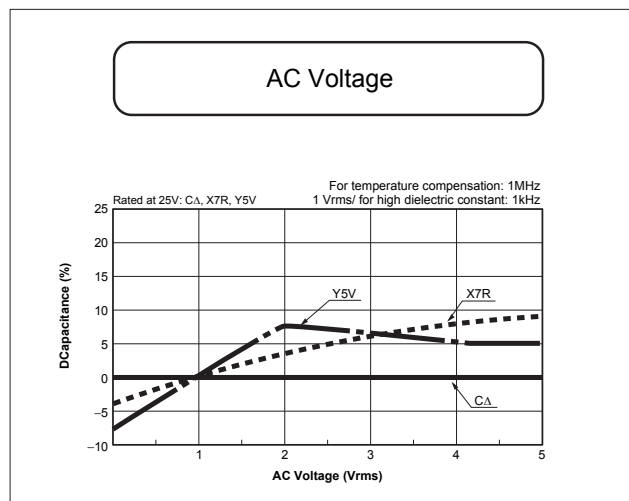
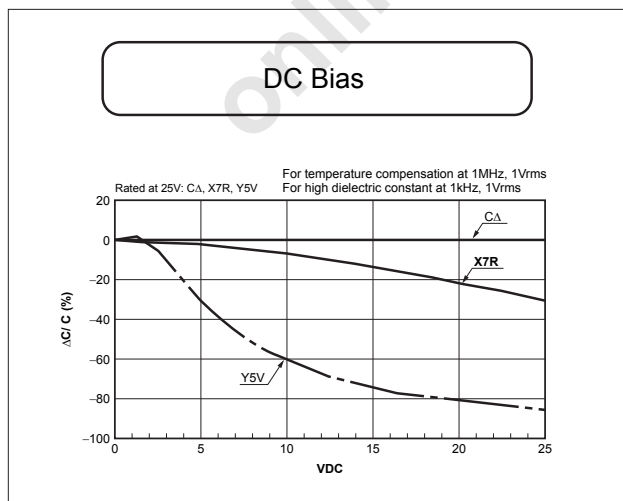
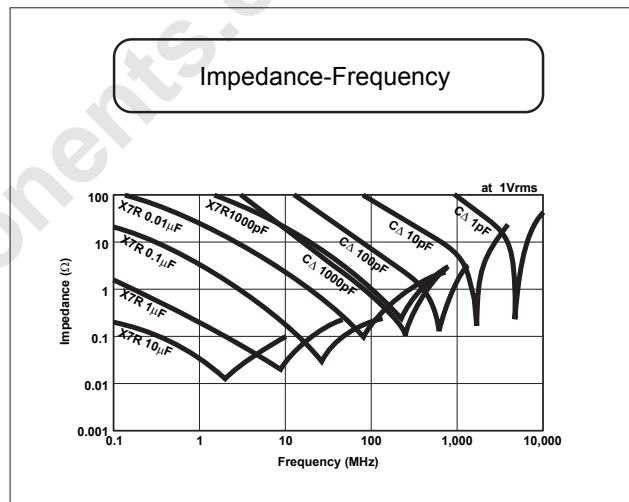
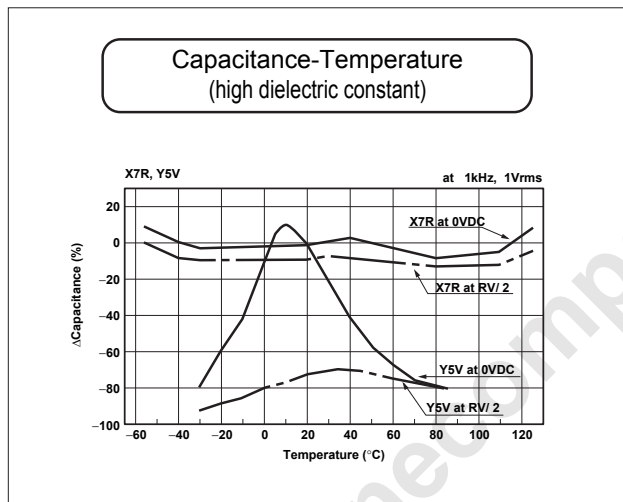
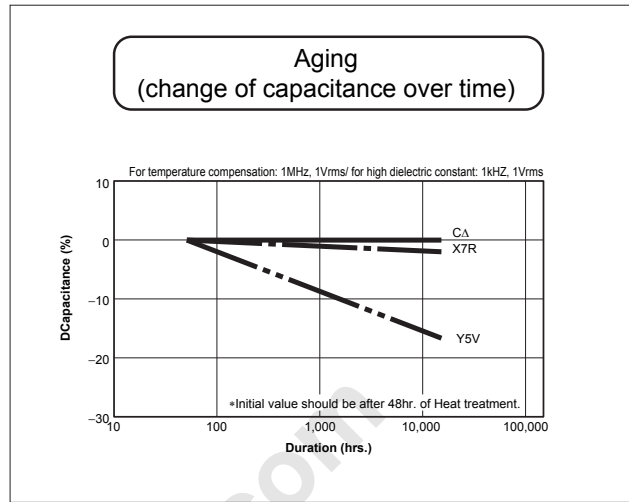
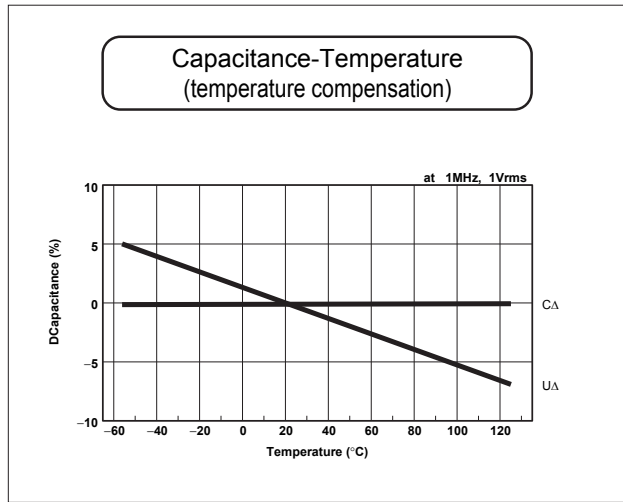

Please verify individual characteristics at the design stage to ensure total suitability.

## Test Conditions and Specifications for Temperature Compensation type (CΔ to UΔ • SL Characteristics)

Test Items		Specifications (C: nominal capacitance)	Test Conditions								
Capacitance Value		Within tolerance	<table border="1"> <tr> <td>C≤1000pF</td> <td>1MHz±10%</td> <td rowspan="2">0.5 to 5Vrms</td> </tr> <tr> <td>C&gt;1000pF</td> <td>1kHz±10%</td> </tr> </table>	C≤1000pF	1MHz±10%	0.5 to 5Vrms	C>1000pF	1kHz±10%			
C≤1000pF	1MHz±10%	0.5 to 5Vrms									
C>1000pF	1kHz±10%										
Q		C≥30pF: Q≥1000 C<30pF: Q≥400+20C									
Insulation resistance (IR) (*5)		10,000MΩ or 500MΩ • μF min., whichever is less	Measured after the rated voltage is applied for one minute at normal room temperature and humidity. (*3)								
Dielectric resistance (*5)		No problem observed	(*1) Apply 3 times of the rated voltage for 1 to 5 seconds.								
Appearance		No problem observed	Microscope (10×magnification)								
Termination strength		No problem observed	Apply a sideward force of 500g (5N) (*2) to a PCB-mounted sample.								
Bending strength		No mechanical damage at 1mm bent	Glass epoxy PCB (t=1.6mm); fulcrum Spacing: 90mm; for 10 seconds.								
Vibration test	Appearance	No significant change is detected	Vibration frequency: 10 to 55 (Hz) Amplitude: 1.5mm Sweeping condition: 10→55→10Hz/ min. In X, Y and Z directions: 2 hours each Total 6 hours								
	ΔC	Within tolerance									
	Q	C≥30pF: Q≥1000 C<30pF: Q≥400+20C									
Soldering heat resistance	Appearance	No significant change is detected	Soak the sample in 260°C±5°C solder for 10±0.5 seconds and place in a room at normal temperature and humidity; measure after 24±2 hours. (Preheating Conditions)								
	ΔC	±2.5% or ±0.25pF max., whichever is larger									
	Q	C≥30pF: Q≥1000 C<30pF: Q≥400+20C									
	IR (*5)	10,000MΩ or 500MΩ • μF min., whichever is smaller									
	Withstand voltage(*5)	Resists without problem									
Solderability	Ni/ Br termination: 90% min.		Soaking Condition								
			<table border="1"> <tr> <th>Order</th> <th>Temperature</th> <th>Time</th> </tr> <tr> <td>1</td> <td>80 to 100°C</td> <td>2 minutes</td> </tr> <tr> <td>2</td> <td>150 to 200°C</td> <td>2 minutes</td> </tr> </table>	Order	Temperature	Time	1	80 to 100°C	2 minutes	2	150 to 200°C
Order	Temperature	Time									
1	80 to 100°C	2 minutes									
2	150 to 200°C	2 minutes									
Temperature cycle	Appearance	No significant change is detected	(Cycle) Normal room temperature (3 min.) → Lowest operation temperature (30 min.) → Normal room temperature (3 min.) → Highest operation temperature (30 min.) → After five cycles, measure after 24±2 hours.								
	ΔC	±2.5% or ±0.25pF max., whichever is larger									
	Q	C≥30pF: Q≥1000 C<30pF: Q≥400+20C									
	IR (*5)	10,000MΩ or 500MΩ • μF min., whichever is smaller									
	Withstand voltage(*5)	Resists without problem									
Load humidity test (*4)	Appearance	No significant change is detected	After applying rated voltage for 500+24/ -0 hours in pre-condition at 40±2°C, humidity 90 to 95%RH allow parts to stabilize for 48±4 hours, at room temperature before making measurements.								
	ΔC	±7.5% or ±0.75pF max., whichever is larger									
	Q	C≥30pF: Q≥200 C<30pF: Q≥100+10C/ 3									
	IR (*5)	500MΩ or 25MΩ • μF min., whichever is smaller									
High-temperature with loading	Appearance	No significant change is detected	After applying (*1) twice of the rated voltage at a temperature of 125±3°C for 1000+48/ -0 hours, measure the sample after storing 24±2 hours.								
	ΔC	±3% or ±0.3pF max., whichever is larger									
	Q	C≥30pF: Q≥350 10pF≤C<30pF: Q≥275+5C/ 2 C<10pF: Q≥200+10C									
	IR (*5)	1,000MΩ or 50MΩ • μF min., whichever is smaller									

\*1 For the CF series, use 1.5 times when the rated voltage is 250V; use/ 1.2 times when the rated voltage exceeds 630V.

\*2 2N at 0201 Size

\*3 Apply 500V for 1 minute in case the rated voltage is 630V or higher.

\*4 Except CF series.

\*5 The charge and discharge current of the capacitor must not exceed 50mA.

# Multilayer Ceramic Chip Capacitors Test Conditions and Standards

onlinecomponents.com



## Test Conditions and Specifications for High Dielectric Type (X5R, X7R, Y5V)

Test Items	Specifications		Test Conditions									
	X7R/ X5R	Y5V										
Capacitance Value	Within tolerance		Do previous treatment (*8, *14) <table border="1"> <thead> <tr> <th>Capacitance</th> <th>Fire</th> <th>Vol</th> </tr> </thead> <tbody> <tr> <td>C≤10μF</td> <td>1kHz±10%</td> <td>1.0±0.2Vrms</td> </tr> <tr> <td>C&gt;10μF</td> <td>120Hz±10%</td> <td>0.5±0.2Vrms</td> </tr> </tbody> </table>	Capacitance	Fire	Vol	C≤10μF	1kHz±10%	1.0±0.2Vrms	C>10μF	120Hz±10%	0.5±0.2Vrms
Capacitance	Fire	Vol										
C≤10μF	1kHz±10%	1.0±0.2Vrms										
C>10μF	120Hz±10%	0.5±0.2Vrms										
tanδ (%)	2.5% max., 3.5% max. (*2), 7.0% max. (*12) 5.0% max. (*3), 7.5% max. (*17)	5.0% max., 7.0% max. (*13) 9.0% max. (*4), 12.5% max. (*5)	Measured after the rated voltage is applied for 2 minutes at normal room temperature and humidity. (*10)									
Insulation resistance (IR) (*15)	10,000MΩ or 500MΩ · μF min., whichever is less		(*1) Apply 2.5 times of the rated voltage for 1 to 5 seconds.									
Dielectric resistance (*15)	No problem observed											
Appearance	No problem observed		Microscope (10×magnification)									
Termination strength (*6)	No problem observed		Apply a sideward force of 500g (5N) (*16) to a PCB-mounted sample.									
Bending strength test (*6)	No problem observed at 1mm bent		Glass epoxy PCB (*03, 05 type and CA Series: T=0.8mm); fulcrum Spacing: 90mm; for 10 seconds.									
Vibration test	Appearance	No significant change is detected	Vibration frequency: 10 to 55 (Hz) Amplitude: 1.5mm Sweeping condition: 10→55→10Hz/ min. In X, Y and Z directions: 2 hours each Total 6 hours									
	ΔC	Within tolerance										
	tanδ (%)	Satisfies the initial value										
Soldering heat resistance	Appearance	No significant change is detected	Do previous treatment (*8) Soak the sample in 260°C±5°C solder for 10±0.5 seconds and place in a room at normal temperature and humidity; measure after 48±4 hours. (Preheating Conditions) <table border="1"> <thead> <tr> <th>Order</th> <th>Temperature</th> <th>Time</th> </tr> </thead> <tbody> <tr> <td>1</td> <td>80 to 100°C</td> <td>2 minutes</td> </tr> <tr> <td>2</td> <td>150 to 200°C</td> <td>2 minutes</td> </tr> </tbody> </table>	Order	Temperature	Time	1	80 to 100°C	2 minutes	2	150 to 200°C	2 minutes
	Order	Temperature		Time								
	1	80 to 100°C		2 minutes								
	2	150 to 200°C		2 minutes								
	ΔC	Within ±7.5%		Within ±20%								
tanδ (%)	Satisfies the initial value											
IR (*15)	10,000MΩ or 500MΩ · μF min., whichever is smaller											
Withstand voltage (*15)	Resists without problem											
Solderability	Ni/ Br termination: 90% min.		Soaking Condition <table border="1"> <thead> <tr> <th>Solder</th> <th>Temperature</th> <th>Time</th> </tr> </thead> <tbody> <tr> <td>Sn63 Solder</td> <td>235±5°C</td> <td>2±0.5 sec.</td> </tr> <tr> <td>Sn-3Ag-0.5Cu</td> <td>245±5°C</td> <td>3±0.5 sec.</td> </tr> </tbody> </table>	Solder	Temperature	Time	Sn63 Solder	235±5°C	2±0.5 sec.	Sn-3Ag-0.5Cu	245±5°C	3±0.5 sec.
	Solder	Temperature	Time									
Sn63 Solder	235±5°C	2±0.5 sec.										
Sn-3Ag-0.5Cu	245±5°C	3±0.5 sec.										
Temperature cycle	Appearance	No significant change is detected	Do previous treatment (*8) (Cycle) Normal room temperature (3 min.) → Lowest operation temperature (30 min.) → Normal room temperature (3 min.) → Highest operation temperature (30 min.) → After five cycles, measure after 48±4hours.									
ΔC	Within ±7.5%	Within ±20%										
tanδ (%)	Satisfies the initial value											
IR (*15)	10,000MΩ or 500MΩ · μF min., whichever is smaller											
Withstand voltage (*15)	Resists without problem											
Load humidity test (*11)	Appearance	No significant change is detected	Do previous treatment (*9) After applying rated voltage at 40±2°C and humidity 90 to 95%RH, for 500+24/ -0 hours and keep at room condition for 48±4 hours then measure and check the specification limits.									
	ΔC	Within ±12.5%		Within ±30%								
	tanδ (%)	200% max. of initial value		150% max. of initial value								
	IR (*15)	500MΩ or 25MΩ · μF min., whichever is smaller										
High-temperature with loading	Appearance	No significant change is detected	Do previous treatment (*9) After applying twice (*7) of the rated voltage at the highest operating temperature for 1000+48/ -0 hours, measure the sample after storing 48±4 hours.									
	ΔC	Within ±12.5%		Within ±30%								
	tanδ (%)	200% max. of initial value		150% max. of initial value								
	IR (*15)	1,000MΩ or 50MΩ · μF min., whichever is smaller										

- \*1 Use 1.5 times when the rated voltage is 250V or over.  
Use 1.2 times when the rated voltage is 630V or over.
- \*2 X7R 16V/ 25V type.
- \*3 Apply to X5R16V/ 25V type, X7R 6.3V/ 10V type.
- \*4 Apply to Y5V 16V type, CM32Y5V335 to 106 (25V Type).
- \*5 Apply to Y5V 6.3V/ 10V type. Apply 16% max. to CM21Y5V106/ CM316Y5V226.
- \*6 Exclude CT series with thickness of less than 0.66mm and CA series.
- \*7 Use 1.5 times when the rated voltage is 4V/ 6.3V/ 10V/ 250V and 100V (32X7R474/ 43X7R105/ 55X7R105).  
Use 1.2 times when the rated voltage is 630V or over.
- \*8 Keep specimen at 150°C+0/ -10°C for one hour, leave specimen at room ambient for 48±4 hours.
- \*9 Apply the same test condition for one hour, then leave the specimen at room ambient for 48±4 hours.

- \*10 For the CF series over 630V, apply 500V for 1 minute at room ambient.
- \*11 Except CF series.
- \*12 Apply to X5R 10V type.
- \*13 Apply to 25V series of CM105Y5V154 over, CM21Y5V105 over, 316Y5V155 over.
- \*14 Measurement condition 1kHz, 1Vrms for Y5V, C<47μF type.
- \*15 The charge/ discharge current of the capacitor must not exceed 50mA.
- \*16 2N at 0201 Size
- \*17 Apply to X5R 4V and 6.3V type.

\* The above test conditions and standards do not apply to products with optional specifications.

# Multilayer Ceramic Chip Capacitors Packaging Options



onlinecomponents.com  
THE ONLINE DISTRIBUTOR OF ELECTRONIC COMPONENTS

## Tape and Reel

• Reel

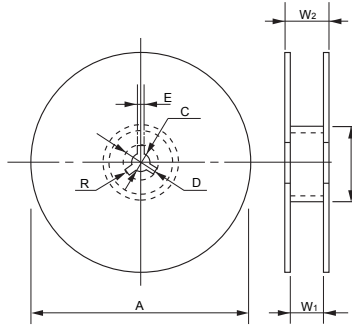

## Reel

(Unit: mm)

Code Reel	A	B	C	D
7-inch Reel (CODE: T, H)	180 <sup>+0</sup> <sub>-2.0</sub>	φ60 min.	13±0.5	21±0.8
13-inch Reel (CODE: L, N)	330±2.0	φ100±1.0		
Code Reel	E	W <sub>1</sub>	W <sub>2</sub>	R
7-inch Reel (CODE: T, H)	2.0±0.5	10.0±1.5	16.5 max.	1.0
13-inch Reel (CODE: L, N)		9.5±1.0		

\* Carrier tape width 8mm.

For size 42 (1808) or over, Tape width 12mm and W<sub>1</sub>: 14±1.5, W<sub>2</sub>: 18.4mm max.

F=2mm (03, 05, 105 Type)

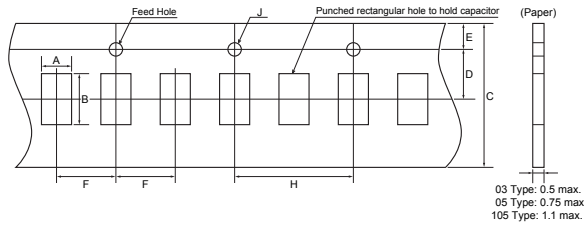

F=4mm (105, D11, D12, F12, 21, 316, 32, 42, 52 Type)

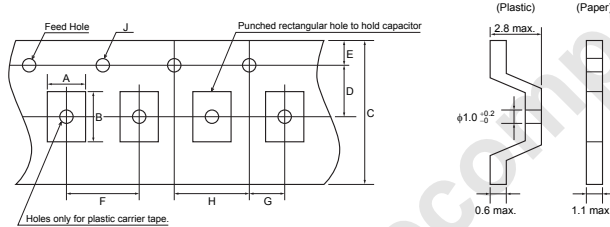

F=8mm (43, 55 Type)

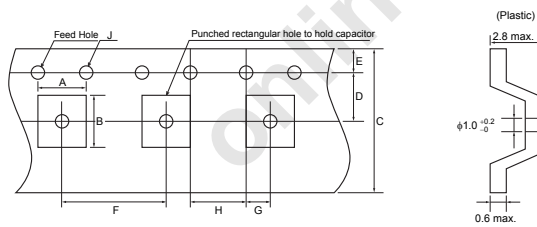

## Bulk Cassette

(Unit: mm)

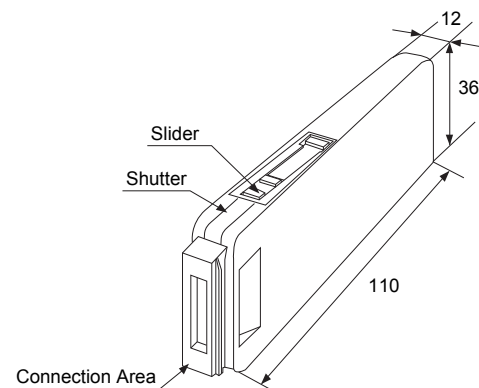

## Carrier Tape

(Unit: mm)

Type	A	B	F
03 (0.6×0.3)	0.37±0.03	0.67±0.03	2.0±0.05
05 (1.0×0.5)	0.65±0.1	1.15±0.1	2.0±0.05
105 (1.6×0.8)	1.0±0.2	1.8±0.2	4.0±0.1
D11 (1.37×1.0)	1.15±0.2	1.55±0.2	4.0±0.1
D12 (1.25×2.0)	1.5±0.2	2.3±0.2	4.0±0.1
F12 (1.25×2.0)	1.5±0.2	2.3±0.2	4.0±0.1
21 (2.0×1.25)	1.5±0.2	2.3±0.2	4.0±0.1
316 (3.2×1.6)	2.0±0.2	3.6±0.2	4.0±0.1
32 (3.2×2.5)	2.9±0.2	3.6±0.2	4.0±0.1
42 (4.5×2.0)	2.4±0.2	4.9±0.2	4.0±0.1
43 (4.5×3.2)	3.6±0.2	4.9±0.2	8.0±0.1
52 (5.7×2.0)	2.4±0.2	6.0±0.2	4.0±0.1
55 (5.7×5.0)	5.3±0.2	6.0±0.2	8.0±0.1

(Unit: mm)

F	Carrier Tape	C	D	E	G	H	J
2.0 ±0.05	8mm Paper	8.0 ±0.3	3.5 ±0.05				
4.0 ±0.1	8mm Plastic			1.75 ±0.1	2.0 ±0.05	4.0 ±0.1	1.5 +0.1/-0
8.0 ±0.1	12mm Plastic	12.0 ±0.3	5.5 ±0.05				

## Circuit Design

1. Once application and assembly environments have been checked, the capacitor may be used in conformance with the rating and performance which are provided in both the catalog and the specifications. Use exceeding that which is specified may result in inferior performance or cause a short, open, smoking, or flaming to occur, etc.
2. Please consult the manufacturer in advance when the capacitor is used in devices such as: devices which deal with human life, i.e. medical devices; devices which are highly public orientated; and devices which demand a high standard of liability.  
Accident or malfunction of devices such as medical devices, space equipment and devices having to do with atomic power could generate grave consequence with respect to human lives or, possibly, a portion of the public. Capacitors used in these devices may require high reliability design different from that of general purpose capacitors.
3. Please use the capacitors in conformance with the operating temperature provided in both the catalog and the specifications.  
Be especially cautious not to exceed the maximum temperature. In the situation the maximum temperature set forth in both the catalog and specifications is exceeded, the capacitor's insulation resistance may deteriorate, power may suddenly surge and short-circuit may occur. The capacitor has a loss, and may self-heat due to equivalent series resistance when alternating electric current is passed therethrough. As this effect becomes especially pronounced in high frequency circuits, please exercise caution.  
When using the capacitor in a (self-heating) circuit, please make sure the surface of the capacitor remains under the maximum temperature for usage. Also, please make certain temperature rises remain below 20°C.
4. Please keep voltage under the rated voltage which is applied to the capacitor. Also, please make certain the peak voltage remains below the rated voltage when AC voltage is super-imposed to the DC voltage.  
In the situation where AC or pulse voltage is employed, ensure average peak voltage does not exceed the rated voltage.  
Exceeding the rated voltage provided in both catalog and specifications may lead to defective withstanding voltage or, in worst case situations, may cause the capacitor to smoke or flame.
5. When the capacitor is to be employed in a circuit in which there is continuous application of a high frequency voltage or a steep pulse voltage, even though it is within the rated voltage, please inquire to the manufacturer.  
In the situation the capacitor is to be employed using a high frequency AC voltage or a extremely fast rising pulse voltage, even though it is within the rated voltage, it is possible capacitor reliability will deteriorate.
6. It is a common phenomenon of high-dielectric products to have a deteriorated amount of static electricity due to the application of DC voltage. Due caution is necessary as the degree of deterioration varies depending on the quality of capacitor materials, capacity, as well as the load voltage at the time of operation.
7. Do not use the capacitor in an environment where it might easily exceed the respective provisions concerning shock and vibration specified in the catalog and specifications.  
In addition, it is a common piezo phenomenon of high dielectric products to have some voltage due to vibration or to have noise due to voltage change. Please contact sales in such case.
8. If the electrostatic capacity value of the delivered capacitor is within the specified tolerance, please consider this when designing the respective product in order that the assembled product function appropriately.
9. Please contact us upon using conductive adhesives.

## Storage

1. If the component is stored in minimal packaging (a heat-sealed or chuck-type plastic bag), the bag should be kept closed. Once the bag has been opened, reseal it or store it in a desiccator.
2. Keep storage place temperature +5 to +35 degree C, humidity 45 to 70% RH.
3. The storage atmosphere must be free of gas containing sulfur and chlorine. Also, avoid exposing the product to saline moisture. If the product is exposed to such atmospheres, the terminals will oxidize and solderability will be effected.
4. Precautions 1) to 3) apply to chip capacitors packaged in carrier tapes and bulk cases.
5. The solderability is assured for 12 months from our shipping date (six months for silver palladium) if the above storage precautions are followed.
6. Chip capacitors may crack if exposed to hydrogen (H<sub>2</sub>) gas while sealed or if coated with silicon, which generates hydrogen gas.

## Dimensions for recommended typical land

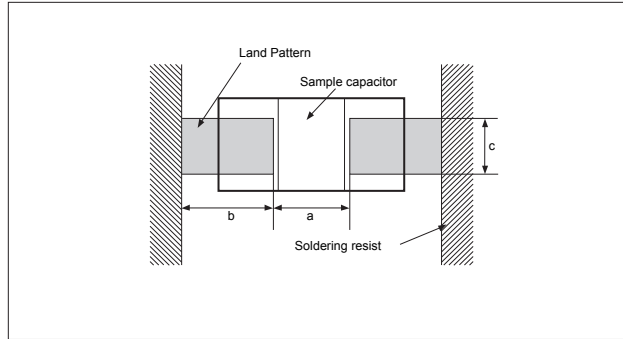

## Standard

(Unit: mm)

Size	L×W	a	b	c
03	0.6×0.3	0.20 to 0.30	0.25 to 0.35	0.30 to 0.40
05	1.0×0.5	0.30 to 0.50	0.35 to 0.45	0.40 to 0.60
105	1.6×0.8	0.70 to 1.00	0.80 to 1.00	0.60 to 0.80
21	2.0×1.25	1.00 to 1.30	1.00 to 1.20	0.80 to 1.10
316	3.2×1.6	2.10 to 2.50	1.10 to 1.30	1.00 to 1.30
32	3.2×2.5	2.10 to 2.50	1.10 to 1.30	1.90 to 2.30
42	4.5×2.0	2.50 to 3.20	1.80 to 2.30	1.50 to 1.80
43	4.5×3.2	2.50 to 3.20	1.80 to 2.30	2.60 to 3.00
52	5.7×2.0	4.20 to 4.70	2.00 to 2.50	1.50 to 1.80
55	5.7×5.0	4.20 to 4.70	2.00 to 2.50	4.20 to 4.70

\* CA series: Please refer applicable page.

When mounting the capacitor to the substrate, it is important to consider carefully that the amount of solder (size of fillet) used has a direct effect upon the capacitor once it is mounted.

- The greater the amount of solder, the greater the stress to the elements. As this may cause the substrate to break or crack, it is important to establish the appropriate dimensions with regard to the amount of solder when designing the land of the substrate.
- In the situation where two or more devices are mounted onto a common land, separate the device into exclusive pads by using soldering resist.

## Automotive Series

(Unit: mm)

Size	L×W	a	b	c
105	1.6×0.8	0.60 to 0.90	0.80 to 1.00	0.70 to 1.00
21	2.0×1.25	0.90 to 1.20	0.80 to 1.20	0.90 to 1.40
316	3.2×1.6	1.40 to 1.90	1.00 to 1.30	1.30 to 1.80

## Ideal Solder Thickness

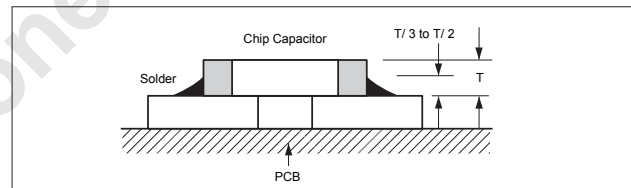

## Typical mounting problems

Item	Not recommended example	Recommended example/ Separated by solder
Multiple parts mount		
Mount with leaded parts		
Wire soldering after mounting		
Overview		

## Mounting Design

The chip could crack if the PCB warps during processing after the chip has been soldered.

## Recommended chip position on PCB to minimize stress from PCB warpage



## Actual Mounting

- 1) If the position of the vacuum nozzle is too low, a large force may be applied to the chip capacitor during mounting, resulting in cracking.
- 2) During mounting, set the nozzle pressure to a static load of 100 to 300 gf.
- 3) To minimize the shock of the vacuum nozzle, provide a support pin on the back of the PCB to minimize PCB flexure.



- 4) Bottom position of pick up nozzle should be adjusted to the top surface of a substrate which camber is corrected.
- 5) To reduce the possibility of chipping and cracks, minimize vibration to chips stored in a bulk case.
- 6) The discharge pressure must be adjusted to the part size. Verify the pressure during setup to avoid fracturing or cracking the chips capacitors.

## Resin Mold

- 1) If a large amount of resin is used for molding the chip, cracks may occur due to contraction stress during curing. To avoid such cracks, use a low shrinkage resin.
- 2) The insulation resistance of the chip will degrade due to moisture absorption. Use a low moisture absorption resin.
- 3) Check carefully that the resin does not generate a decomposition gas or reaction gas during the curing process or during normal storage. Such gases may crack the chip capacitor or damage the device itself.

## Soldering Method

- 1) Ceramic is easily damaged by rapid heating or cooling. If some heat shock is unavoidable, preheat enough to limit the temperature difference (Delta T) to within 130 degree Celsius.
- 2) The product size 1.0×0.5mm to 3.2×1.6mm can be used in reflow and wave soldering, and the product size of over 3.2×2.5mm, 0.6×0.3mm, and capacitor arrays can be used in reflow.  
Circuit shortage and smoking can be created by using capacitors which are used neglecting the above caution.
- 3) Please see our recommended soldering conditions.
- 4) In case of using Sn-Zn Solder, please contact us in advance.

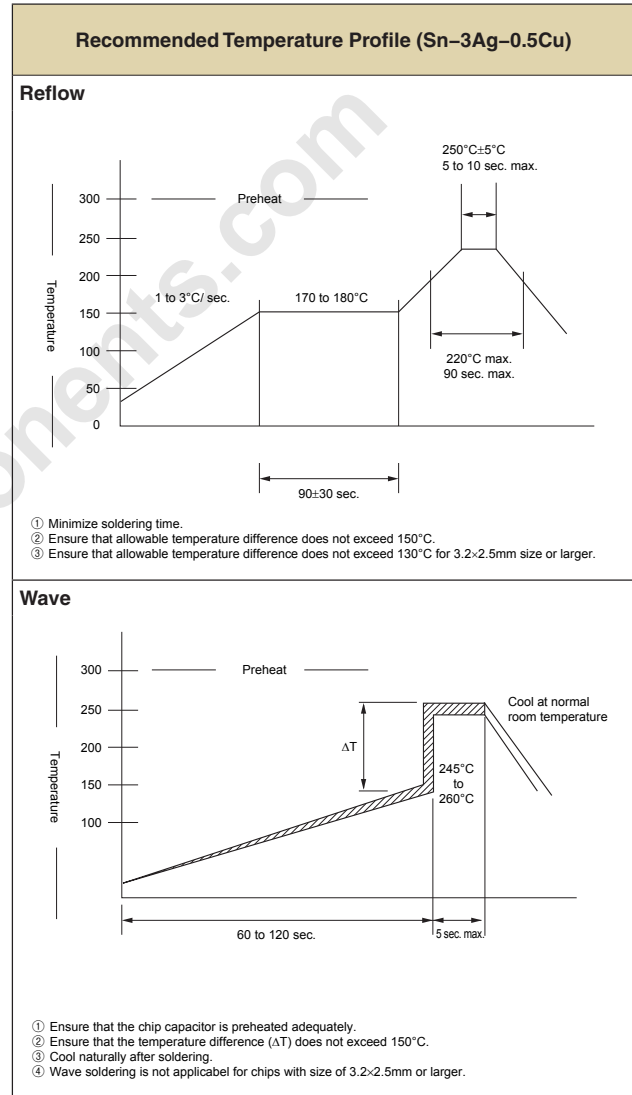
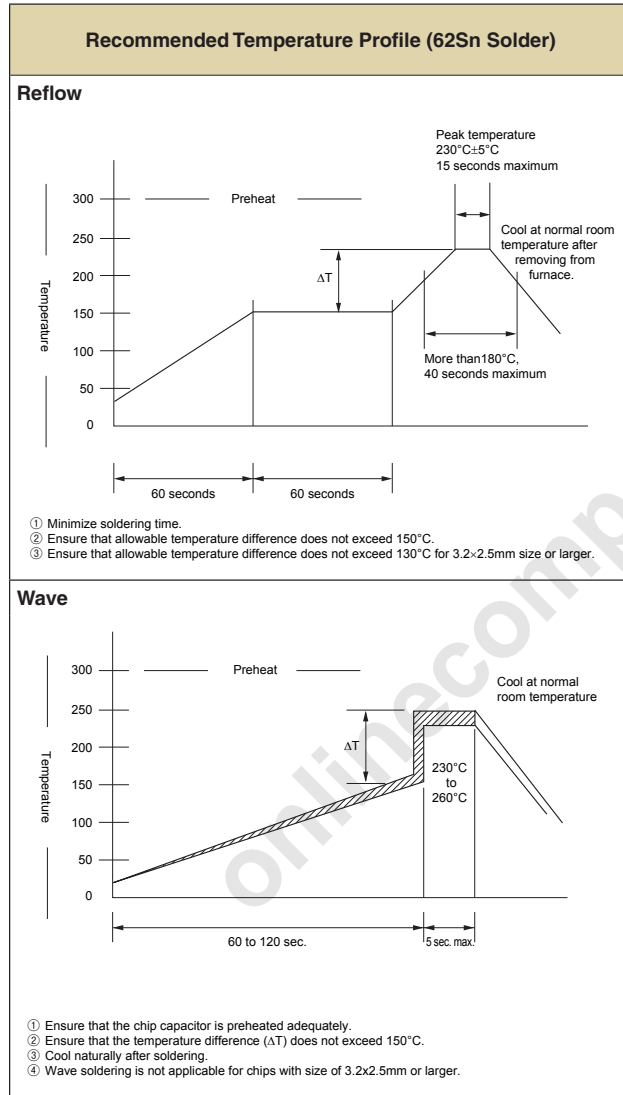

## Soldering iron

- |                                |             |   |
|--------------------------------|-------------|---|
| 1) Temperature of iron chip    | 380°C max.  | 5) Cautions   |
| 2) Wattage                     | 80W max.    | a) Pre-heating is necessary Rapid heating must be avoided.<br>Delta T ≤ 150°C |
| 3) Tip shape of soldering iron | φ3.0mm max. | b) Avoid direct touching to capacitors.                                       |
| 4) Soldering Time              | 3 sec. max. | c) Avoid rapid cooling after soldering. Natural cooling is recommended.       |