

REVISIONS			
LTR	DESCRIPTION	DATE	APPROVED
F1	REVISED PER ECO-11-005139	29MAR11	HMR

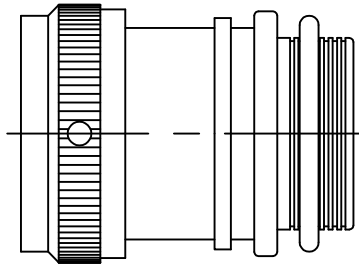

**CODE 18
STRAIGHT ADAPTER**

NOTES:

1. THIS PRODUCT IS DESIGNED TO TERMINATE A BRAIDED CABLE SHIELD AND A HEAT SHRINKABLE LIPPED BOOT TO A CONNECTOR.
2. SEE CH00-0250-008 FOR ORDERING INFORMATION, MODIFICATIONS AND ADDITIONAL DIMENSIONS.
3. SEE DRAWING "TR" FOR DETAIL ON TINEL-LOCK RING. RINGS ARE DESIGNED TO BE HEATED ELECTRICALLY. ALL RINGS ARE MARKED WITH THERMOCHROMIC PAINT WHICH CHANGES COLOR WHEN INSTALLATION TEMPERATURE IS REACHED.
4. ADAPTER TO BE PERMANENTLY MARKED WITH CODE IDENT. NO. AND PART NO. LESS RING DESIGNATOR (E.G.: 06090-TXR18AB00-1406). RINGS SHALL BEAR NO MARKING.
5. FOR LARGER ENTRY SIZES, A 2 PIECE ADAPTER (TYPE II) IS SUPPLIED.
6. ADAPTER MATES TO MIL-C-5015D, CLASS A, E & R, MS3100, MS3101 & MS3106. RESILIENT INSERT, SOLDER TYPE & BENDIX 10-214, CANNON CA-RX COMMERCIAL CRIMP TYPE.
7. ADDITIONAL PIECE(S) SUPPLIED WHEN CONNECTOR MANUFACTURER IS UNKNOWN ("D" IN TABLE III) AND ENTRY SIZE DOES NOT EXCEED VALUE IN TABLE I. SEE FIGURE A PAGE 2 OF 4.
8. ALL THREAD SIZES FOR ORDER NO. APPLY.
9. ANTI-ROTATIONAL SET SCREW, 3 THREADED HOLES 120°±5° APART, SINGLE MATING SET SCREW SUPPLIED: AN565DC4H2. NOT REQUIRED FOR TYPE II ADAPTERS.

IF THIS DOCUMENT IS PRINTED IT BECOMES UNCONTROLLED
CHECK FOR THE LATEST REVISION

TINEL-LOCK™ is a trademark of TE CONNECTIVITY.

©2005,2011 Tyco Electronics Corporation.a TE connectivity Ltd.company. All rights reserved.

SPECIFICATION CONTROL DRAWING

UNLESS OTHERWISE SPECIFIED DIMENSIONS ARE IN INCHES. METRIC DIMENSIONS ARE IN BRACKETS. DECIMALS .XXX ± 0.005 [0.13 mm] .XX ± 0.01 [0.25 mm] .X ± 0.1 [0.50 mm] ANGLES .X ± 0.5 DEG	DRAWN R. RAMIREZ 04-19-93	TE Connectivity 300 Constitution Drive Menlo Park, CA. 94025 U.S.A.	
	CHECKED --- ---		
	APPROVED W.C.GAY 04-19-93	TITLE TINEL-LOCK ADAPTER	
	REVISED MFORONDA 2/24/05 CAD NAME: R050057A.dwg	SIZE A CODE IDENT. NO. 06090 DWG. NO. TXR18	REV F1
THIRD ANGLE PROJECTION 	DO NOT SCALE THIS DRAWING		SHEET 1 OF 4

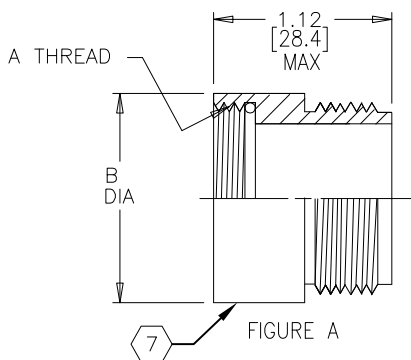
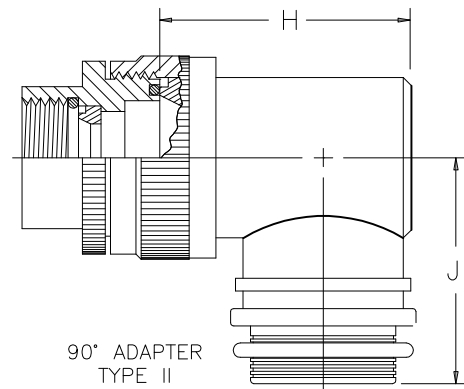
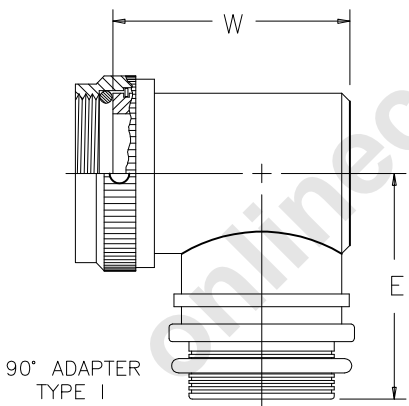
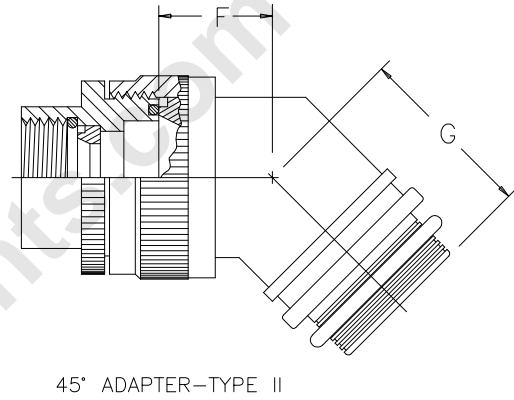
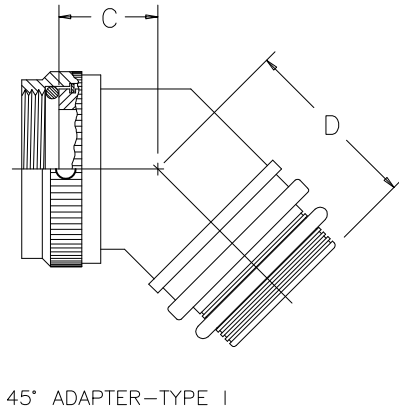
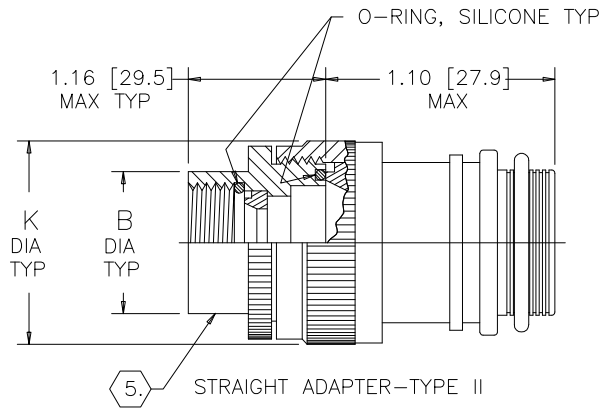
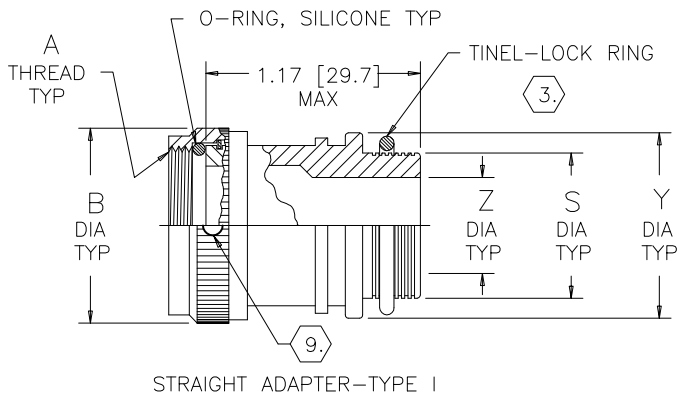

IF THIS DOCUMENT IS PRINTED IT BECOMES UNCONTROLLED
CHECK FOR THE LATEST REVISION

SPECIFICATION CONTROL DRAWING

SIZE A	CODE IDENT. NO. 06090	DWG. NO. TXR18	REV F1
DO NOT SCALE THIS DRAWING		CAD NAME: R050057B.dwg	SHEET 2 OF 4

TABLE I

ORDER NO.	SHELL SIZE	MFR CODE TABLE III	MAX ENTRY SIZE TYPE I	A THREAD CLASS 2B	B DIA MAX	C MAX	D MAX	E MAX			
08	8S	B	04	.375-32 UNEF	.73 [18.5]	.80 [20.3]	.92 [23.4]	1.23 [31.2]			
		C		.438-28 UNEF							
		A,R		.438-27 UNS							
		D (7)		(8)							
10	10S	-	06	.500-28 UNEF	.79 [20.1]	.83 [21.1]	.95 [24.1]	1.23 [31.2]			
11	10SL	C	07	.562-24 UNEF	.85 [21.6]	.83 [21.1]	.95 [24.1]	1.23 [31.2]			
		A,B,R		.625-24 UNEF	.92 [23.4]						
		D (7)		(8)	.92 [23.4]						
12	12 & 12S	B,C	08	.625-24 UNEF	.92 [23.4]	.83 [21.1]	.95 [24.1]	1.23 [31.2]			
		A,R		.688-24 UNEF	.98 [24.9]				.86 [21.8]	.98 [24.9]	1.30 [33.0]
		D (7)		(8)	.98 [24.9]				.86 [21.8]	.98 [24.9]	1.30 [33.0]
14	14 & 14S	-	10	.750-20 UNEF	1.04 [26.4]	.86 [21.8]	.98 [24.9]	1.30 [33.0]			
16	16 & 16S	-	12	.875-20 UNEF	1.23 [31.2]	.89 [22.6]	1.02 [25.9]	1.42 [36.1]			
18	18	-	12	1.000-20 UNEF	1.35 [34.3]	.92 [23.4]	1.05 [26.7]	1.48 [37.6]			
20	20	A,B,C	16	1.125-18 UNEF	1.48 [37.6]	.95 [24.1]	1.08 [27.4]	1.55 [39.4]			
		R		1.125-24 UNS							
		D (7)		(8)							
22	22	-	18	1.250-18 UNEF	1.60 [40.6]	.98 [24.9]	1.11 [28.2]	1.61 [40.9]			
24	24	-	20	1.375-18 UNEF	1.73 [43.9]	.98 [24.9]	1.11 [28.2]	1.67 [42.4]			
28	28	-	22	1.625-18 UNEF	2.10 [53.3]	1.08 [27.4]	1.17 [29.7]	1.86 [47.2]			
32	32	B,C	24	1.875-16 UN	2.23 [56.6]	1.11 [28.2]	1.23 [31.2]	1.92 [48.8]			
		A,R		1.906-18 UN							
		D (7)		(8)							
36	36	B	24	2.062-16 UNS	2.48 [63.0]	1.23 [31.2]	1.27 [32.3]	2.05 [52.1]			
		R		2.062-20 UNS							
		C		2.125-16 UN							
		A		2.125-18 UNS							
		D (7)		(8)							
40	40	B	24	2.312-16 UNS	2.73 [69.3]	1.27 [32.3]	1.30 [33.0]	2.17 [55.1]			
		A,R		2.375-16 UN							
		D (7)		(8)							
44	44	-	24	2.625-16 UN	3.23 [82.0]	1.34 [34.0]	1.36 [34.5]	2.42 [61.5]			
48	48	C	24	2.812-18 UNS	3.23 [82.0]	1.34 [34.0]	1.36 [34.5]	2.42 [61.5]			
		A,R		2.875-16 UN							
		D (7)		(8)							

IF THIS DOCUMENT IS PRINTED IT BECOMES UNCONTROLLED
CHECK FOR THE LATEST REVISION

SPECIFICATION CONTROL DRAWING

SIZE A	CODE IDENT. NO. 06090	DWG. NO. TXR18	REV F1
DO NOT SCALE THIS DRAWING		CAD NAME: R050057C.dwg	SHEET 3 OF 4

TABLE II

ENTRY SIZE	Z +.010 -.020	S DIA	Y ±.015 [±0.38]	W MAX	F MAX	G MAX	J MAX	H MAX	K MAX
04	.250 [6.35]	.376 [9.56] .370 [9.39]	.550 [13.97]	1.24 [31.5]	N/A	N/A	N/A	N/A	N/A
05	.312 [7.92]	.438 [11.13] .432 [10.97]	.612 [15.54]	1.35 [34.3]	.77 [19.6]	.93 [23.6]	1.16 [29.5]	1.19 [30.2]	.80 [20.3]
06	.375 [9.52]	.501 [12.73] .495 [12.57]	.675 [17.14]	1.41 [35.8]	.77 [19.6]	.93 [23.6]	1.16 [29.5]	1.19 [30.2]	.80 [20.3]
07	.437 [11.09]	.563 [14.31] .556 [14.12]	.737 [18.71]	1.47 [37.3]	.80 [20.3]	.95 [24.1]	1.22 [31.0]	1.38 [35.1]	.92 [23.4]
08	.500 [12.70]	.626 [15.91] .619 [15.72]	.800 [20.32]	1.54 [39.1]	.80 [20.3]	.95 [24.1]	1.22 [31.0]	1.38 [35.1]	.92 [23.4]
10	.625 [15.87]	.752 [19.11] .742 [18.84]	.925 [23.49]	1.63 [41.4]	.84 [21.3]	1.00 [25.4]	1.35 [34.3]	1.51 [38.4]	1.18 [30.0]
12	.750 [19.05]	.877 [22.28] .867 [22.02]	1.050 [26.67]	1.79 [45.5]	.86 [21.8]	1.01 [25.7]	1.40 [35.6]	1.63 [41.4]	1.35 [34.3]
14	.875 [22.23]	1.002 [25.46] .991 [25.17]	1.175 [29.84]	1.92 [48.8]	.88 [22.4]	1.04 [26.4]	1.46 [37.1]	1.78 [45.2]	1.41 [35.8]
16	1.000 [25.40]	1.127 [28.63] 1.116 [28.34]	1.300 [33.02]	2.04 [51.8]	.91 [23.1]	1.06 [26.9]	1.53 [38.9]	1.88 [47.8]	1.60 [40.6]
18	1.125 [28.57]	1.252 [31.81] 1.241 [31.52]	1.425 [36.19]	2.16 [54.9]	.93 [23.6]	1.09 [27.7]	1.59 [40.4]	2.01 [51.1]	1.66 [42.2]
20	1.250 [31.75]	1.377 [34.98] 1.366 [34.69]	1.550 [39.37]	2.29 [58.2]	.98 [24.9]	1.13 [28.7]	1.78 [45.2]	2.13 [54.1]	2.04 [51.8]
22	1.375 [34.93]	1.502 [38.15] 1.488 [37.79]	1.675 [42.55]	2.63 [66.8]	1.03 [26.2]	1.38 [35.1]	1.85 [47.0]	2.29 [58.2]	2.23 [56.6]
24	1.500 [38.10]	1.627 [41.33] 1.613 [40.97]	1.800 [45.72]	2.76 [70.1]	1.08 [27.4]	1.44 [36.6]	1.92 [48.8]	2.42 [61.5]	2.23 [56.6]

TABLE III

MFR CODE	CONNECTOR MANUFACTURER (MS 3100, MS 3101 & MS 3106)
A	AMPHENOL-CLASS A
B	BENDIX-CLASS A, E & R
C	CANNON-CLASS A, E & R
D	MFR UNKNOWN, CLASS A, E & R
R	AMPHENOL-CLASS R
—	MFR CODE NOT REQUIRED

SPECIFICATION CONTROL DRAWING

IF THIS DOCUMENT IS PRINTED IT BECOMES UNCONTROLLED
CHECK FOR THE LATEST REVISION

© 2005,2011 Tyco Electronics Corporation.a TE connectivity Ltd.company. All rights reserved.

SIZE	CODE IDENT. NO.	DWG. NO.	REV
A	06090	TXR18	F1
DO NOT SCALE THIS DRAWING		CAD NAME: R050057D.dwg	SHEET 4 OF 4