



Industrial Connectors For Harsh Environments



DEUTSCH



Specialised Capability and Innovation

Deutsch is well known for its high performance connectors and has built a solid reputation world wide in the wire termination and custom integrated interconnection market.

Our expertise has developed over many years of involvement with

- **Building and Construction equipment**
- **Heavy goods vehicles**
- **Off road and marine equipment**
- **Agricultural tractors and farm machinery**
- **Special purpose vehicles**
- **Coaches, buses and commercial vehicles**



In all cases the environments can be tough and life expectancy is long term. Special attention is paid to connector material choice, the operating environments, temperature ranges and above all sealability.

Specific applications such as engine management systems, hydraulic controls, chassis and engine wiring, cab bulkhead through connections, vehicle ABS & EBS, diagnostic and multiplexing are well understood. Deutsch design and development ensures that the right product is offered when working closely with our customers.

Special interfaces are continually being developed for sensors, solenoids, switches, lights, electronic enclosures and fuel systems. In these areas particular attention has to be paid to vibration, through pin sealing and high electrical integrity.



DT Series Standard Products

Deutsch DT Series of environmentally sealed connectors designed for wire to wire applications on engine, transmission, chassis and cab.

There are two versions identified by different colours:-

Grey - Plug with orange wedge lock, Receptacle with green wedge lock. **Black** (preferred) - With enhanced seal retention and green secondary locks.

Note: Component parts are not intermountable but in the fully assembled condition, both grey and black parts are intermateable and interchangeable thus maintaining the higher levels of sealability expected within the Construction, Off-road, Heavy Goods vehicle and Agricultural market.

Wire Sealing Range

Standard - 2.24mm - 3.68mm wire insulation diameter. **Thin wall** - 1.35mm - 3.05mm wire insulation diameter (Identified by an 'E' on the Seal/End Cap).

Part Nos. - Plugs

No. of Ways	Basic Part No.	Standard				With End Cap								
		Grey		Orange Wedge	Black		Grey		Orange Wedge	Black		Green Wedge		
		Std.	Thin wall		Std.	Thin wall	Std.	Thin wall		Std.	Thin wall			
2	DT06-2S	-P004	-C015	W2S	-P012	-CE06	W2S	-P012	-EP04	-CE01	W2S	-EP06	-CE05	W2S-P012
3	DT06-3S	-P004	-C015	W3S	-P012	-CE06	W3S	-P012	-EP04	-CE01	W3S	-EP06	-CE05	W3S-P012
4	DT06-4S	-P004	-C015	W4S	-P012	-CE06	W4S	-P012	-EP04	-CE01	W4S	-EP06	-CE05	W4S-P012
6	DT06-6S	-P004	-C015	W6S	-P012	-CE06	W6S	-P012	-EP04	-CE01	W6S	-EP06	-CE05	W6S-P012
8	DT06-8SA*	-P004	-C015	W8S	-EP07	-CE10	W8S	-P012	-EP04	-CE01	W8S	-EP08	-CE11	W8S-P012
12	DT06-12SA*	-P004	-C015	W12S	-EP07	-CE10	W12S	-P012	-EP04	-CE01	W12S	-EP08	-CE11	W12S-P012

*Available with B, C & D Keyways in Black, Green & Brown respectively.

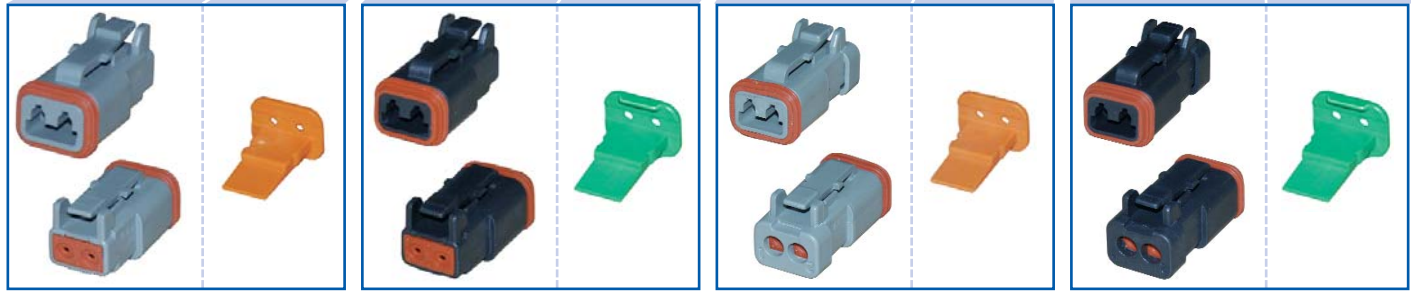

Part Nos. - Receptacles

No. of Ways	Basic Part No.	Standard				With End Cap				
		Grey		Black		Grey		Black		Green Wedge
		Std.	Thin wall	Std.	Thin wall	Std.	Thin wall	Std.	Thin wall	
2	DT04-2P	-P004	-C015	-E004	-CE02	-EP04	-CE01	-E005	-CE03	W2P
3	DT04-3P	-P004	-C015	-E004	-CE02	-EP04	-CE01	-E005	-CE03	W3P
4	DT04-4P	-P004	-C015	-E004	-CE02	-EP04	-CE01	-E005	-CE03	W4P
6	DT04-6P	-P004	-C015	-E004	-CE02	-EP04	-CE01	-E005	-CE03	W6P
8	DT04-8PA*	-P004	-C015	-E004	-CE02	-EP04	-CE01	-E005	-CE03	W8P
12	DT04-12PA*	-P004	-C015	-E004	-CE02	-EP04	-CE01	-E005	-CE03	W12P

*Available with B, C & D Keyways in Black, Green & Brown respectively.



DT Series

Flanges



The DT Flanged Receptacle Series of sealed connectors is available in grey and black with standard or thin wall wire seals. Each receptacle requires a secondary contact lock - e.g. W3P through to W12P coloured green.

Wire Sealing Range

Standard - 2.24mm - 3.68mm wire insulation diameter

Thin wall - 1.35mm - 3.05mm wire insulation diameter

***Note:** Contact Sales Office for 6 Way Drawing

Part Nos. - Receptacles Only

No. of Ways	Basic Part No.	Grey		Black		Green Wedge
		Std.	Thin wall	Std.	Thin wall	
3	DT04-3P	-L012	-CL03	-LE14	-CL06	W3P
4	DT04-4P	-L012	-CL03	-LE14	-CL06	W4P
*6	DT04-6P	-L012	-CL03	-LE14	-CL06	W6P
8	DT04-8PA	-L012	-CL03	-LE14	-CL06	W8P
12	DT04-12PA	-L012	-CL03	-LE14	-CL06	W12P

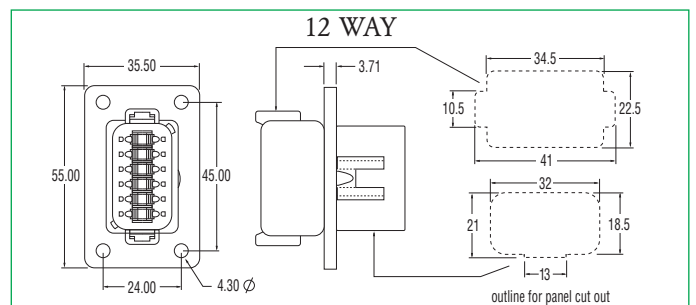
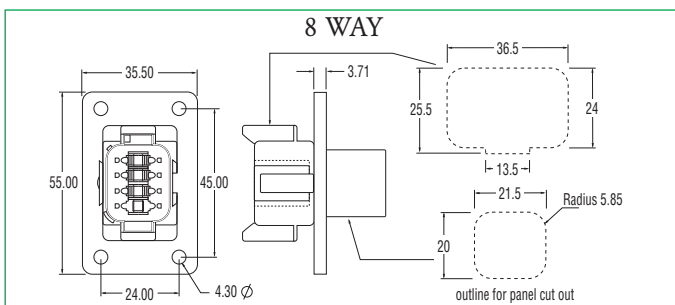
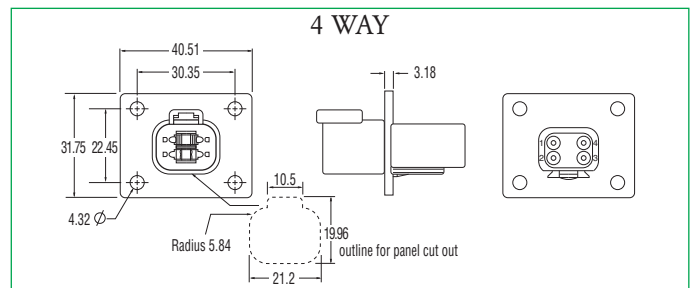
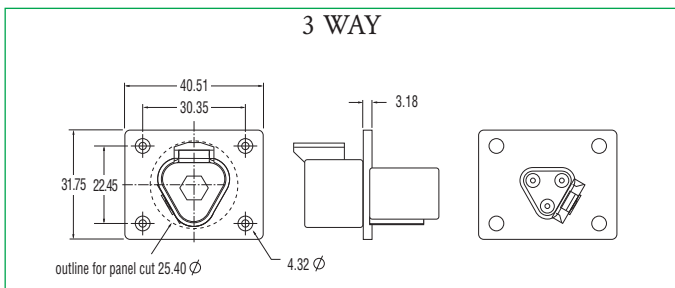

DT Series

Boot Adaptors



To meet the application requirements where wires are to be protected, the DT Series may be supplied with boot adaptors. These will accept shaped boots / sleeves or shrink tubing. Parts for standard or thin wall wire are available.

Wire Sealing Range **Standard** - 2.24mm - 3.68mm wire insulation diameter **Thin wall** - 1.35mm - 3.05mm wire insulation diameter

Part Nos. - Plugs

No. of Ways	Basic Part No.	Grey		Orange Wedge	Black		Green Wedge
		Std.	Thin wall		Std.	Thin wall	
2	DT06-2S	-E008	-CE04	W2S	-EP11	-CE13	W2S -P012
3	DT06-3S	-E008	-CE04	W3S	-EP11	-CE13	W3S -P012
4	DT06-4S	-E008	-CE04	W4S	-EP11	-CE13	W4S -P012
8	DT06-8SA	-E008	-CE04	W8S	-EP11	-CE12	W8S -P012
12	DT06-12SA	-E008	-CE04	W12S	-EP11	-CE12	W12S -P012

Part Nos. - Receptacles

No. of Ways	Basic Part No.	Grey		Black		Wedges
		Std.	Thin wall	Std.	Thin wall	
2	DT04-2P	-E008	-CE04	-EE01	-CE09	W2P
3	DT04-3P	-E008	-CE04	-EE01	-CE09	W3P
4	DT04-4P	-E008	-CE04	-EE01	-CE09	W4P
8	DT04-8PA	-E008	-CE04	-EE01	-CE09	W8P
12	DT04-12PA	-E008	-CE04	-EE01	-CE09	W12P

2 WAY

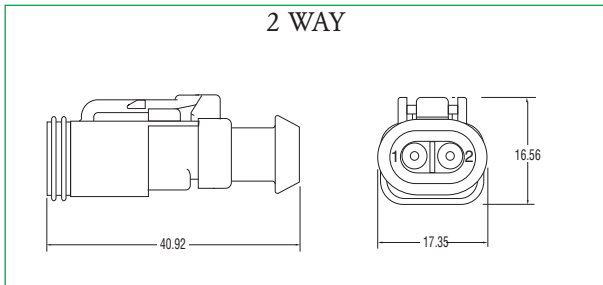

3 WAY

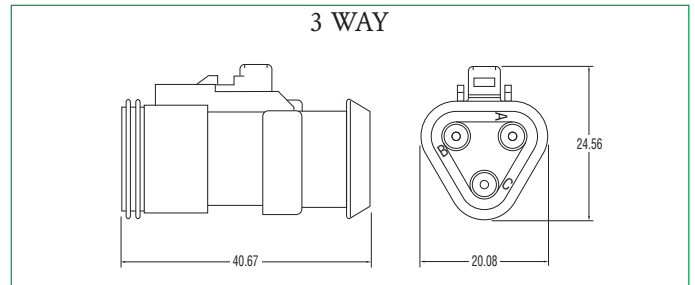

4 WAY

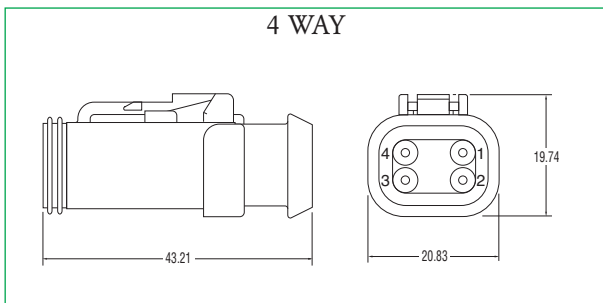

8 WAY

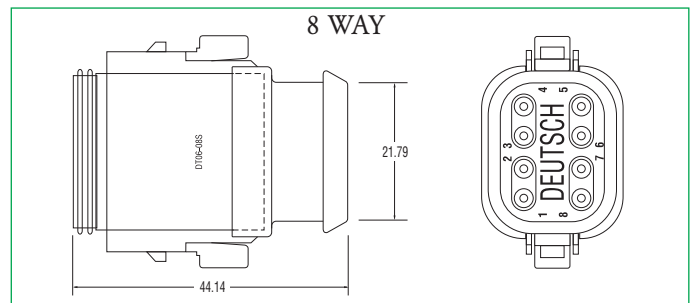

Conduit Adaptors

The Deutsch range of Conduit Adaptors are designed to snap fix onto the full range of Standard DT Connectors (i.e. without end caps). They are available for both plugs and receptacles and the options include Straight and Right Angled Adaptors for 2, 3, 4, 6, 8 & 12 way, plus a Strain Relief version for Jacketed Cables in 2, 3, 4 & 6 way.

2-, 4- and 6 Way

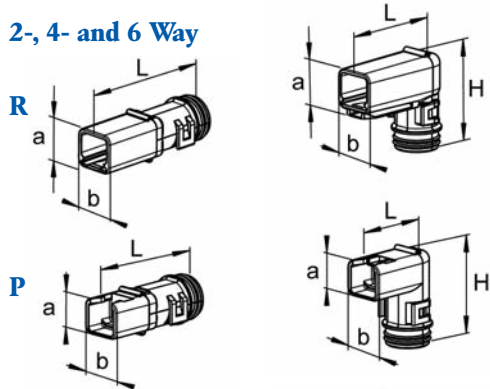

3 Way

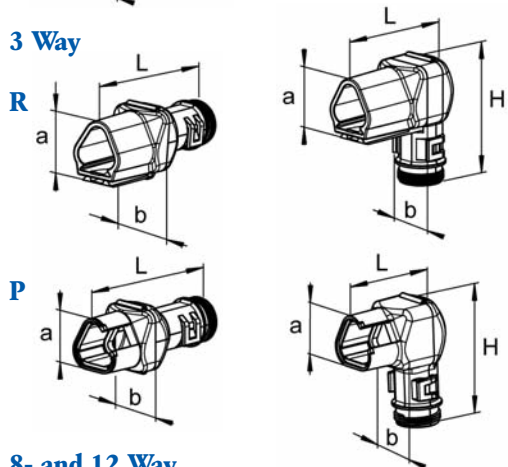

8- and 12 Way

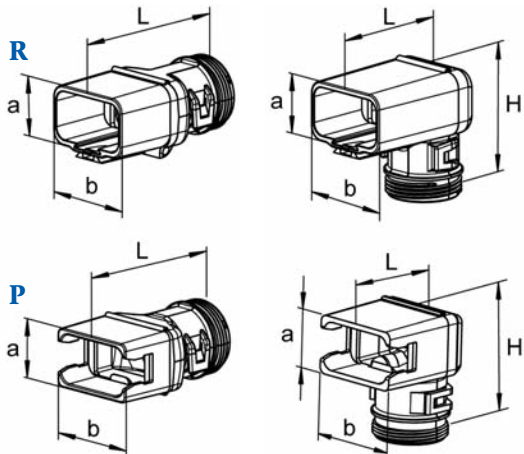

Tube sizes and length additions

(mm added to the tube length for **each** backshell)

	2-way	3-way	4-way	6-way	8-way	12-way
NW6	L+ 16	L+ 18	L+ 16	L+ 18		
NW 7.5	L+ 16	L+ 18	L+ 16	L+ 18		
NW 8.5	L+ 10	L+ 12.5	L+ 10	L+ 12.5	L+ 20	
NW 10	L+ 5	L+ 7	L+ 5	L+ 7	L+ 14	L+ 24.5
NW 13					L+ 8	L+ 16
NW 17						L+ 10

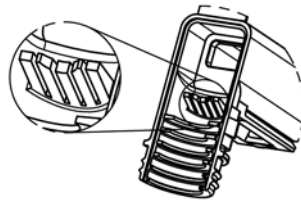

- R** = Receptacle side
- P** = Plug side
- X** = with strain relief for jacketed cable
- Y** = without strain relief

Part Nos. - Plugs

Type:	a	b	L	H	Art.-No.	-X	-Y
2R 180°	18	17	54.5	-	61031-	-23	-33
2R 90°	18	17	41	37	61031-	-24	-34
2P 180°	14	17	45.5	-	61031-	-25	-35
2P 90°	14	17	31	37	61031-	-26	-36
3R 180°	25	23	64.5	-	61051-	-23	-33
3R 90°	25	23	44	48	61051-	-24	-34
3P 180°	21	23	56	-	61051-	-25	-35
3P 90°	21	23	36	48	61051-	-26	-36
4R 180°	22	22	59.5	-	61048-	-23	-33
4R 90°	22	22	43	45	61048-	-24	-34
4P 180°	20	22	55	-	61048-	-25	-35
4P 90°	20	22	33.5	45	61048-	-26	-36
6R 180°	26.5	22	62	-	61057-	-23	-33
6R 90°	26.5	22	46.5	49	61057-	-24	-34
6P 180°	24	22	53.5	-	61057-	-25	-35
6P 90°	24	22	38	49.5	61057-	-26	-36
8R 180°	27.5	28	62	-	61049-		-33
8R 90°	27.5	28	47.5	50.5	61049-		-34
8P 180°	24.5	28.5	57	-	61049-		-35
8P 90°	24.5	28.5	39.5	49	61049-		-36
12R 180°	26	35.5	63.5	-	61052-		-33
12R 90°	26	35.5	54	50.5	61052-		-34
12P 180°	23	36	57.5	-	61052-		-35
12P 90°	23	36	43.5	50.5	61052-		-36

DRB Series

Bulkhead



The 48, 60 or 102 way high density bulkhead connectors are provided with 3 basic parts, a central bulkhead flange and two independent plug and socket assemblies complete with contact secondary locks. Insert arrangements use multiple sizes of contacts from the standard range and may be mounted in either environmental or non

environmental versions. Plug and receptacle mate with a single sturdy jack screw.

No specific tools are required for either insertion or extraction of contacts

Special Products

Diodes

Modules with moulded in semi conductor devices can be mated with the DT Series providing a fully sealed and compact package. Peak reverse voltages up to 600 volts and average forward current up to 4 amps.

2 way: DT04 - 2P - RT01 or RT02. 4 way: DT04 - 4P - RT01 or RT03



Bussing Connectors

These sealed standard DT receptacles feature internal pin type contact buss bar arrangements which eliminate the need for wire splicing. 3 to 12 ways in either nickel or gold plate are available. All will mate with the appropriate DT connectors.



Boxes

Environmentally sealed with either 12 or 24 way DTM interfaces. The flanged header features 90° pins.

Enclosure: EEC - 325X4A (Black with vent hole).
EEC - 325X4B (Black without vent hole).
EEC - 325X4B - E016 (Clear without vent hole).

12 Pin Receptacle - DTM13 - 12PA - R008.

24 Pin Receptacle - DTM13 - 12PA - 12PB - R008



HDP Series

-L015 and -L017

The composite circular connectors may be supplied with threaded or plain adaptors which are colour coded according to wire sealing capability.

Green: Standard (N) **Blue:** Thin Wall (E)

Part Nos. eg.

A 23 way plug and receptacle suitable for size 16AWG contacts.

Plug - for standard wires.

HDP26 - 24 - 23SN - L015

- for thin wall European wires.

HDP26 - 24 - 23SE - L015

Receptacle - for standard wires.

HDP24 - 24 - 23PN - L015

- for thin wall European wires.

HDP24 - 24 - 23PE - L015

Part No. - L017

e.g. Typical Part No. HDP26 - 24 - 23SE - L017

For further details please refer to the HD and HDP Connector Brochure which includes conduit backshells.

Conduit Adaptor

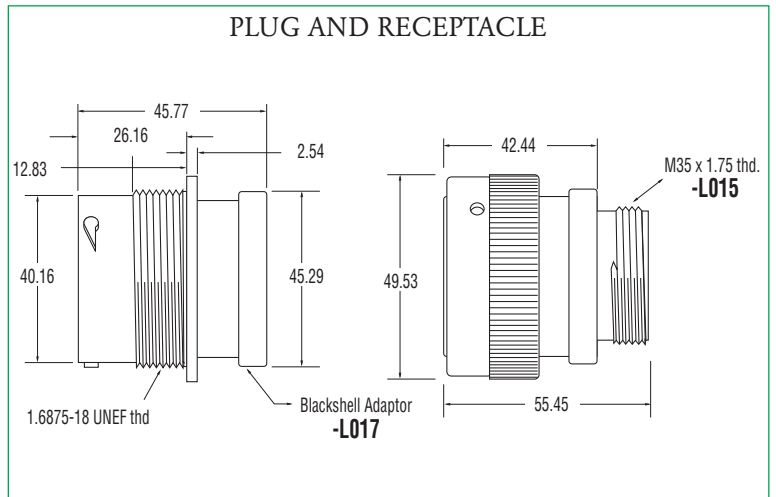

Special Products

Multiplex Connectors

J1939 & ISO/CD 11783-2

A range of components designed to be compatible with the requirements of the 250k bits/sec control and communications networking for Trucks, Buses, Tractors and Agricultural Machinery.

Parts include flange mounted and polarised connectors, "T" splitters and bus terminators. Both shielded and unshielded twisted pair cable can be accommodated.

Further details from our sales office.

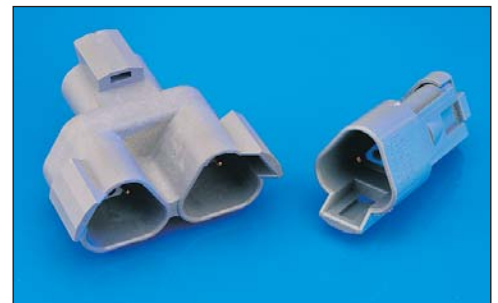

PCB Flangeless Connectors

The DTF Series flangeless headers are designed to be potted into PCB enclosures where space is limited. Parts are environmentally sealed when mated to the Deutsch DT06 plugs. 2, 3, 4, 6 & 12 way will be available (13 amp).

DTMF15-48P is a compact PCB connector with 4 banks of 12 way in A, B, C & D keyway. (7 amp).



How to Strip a Wire for use with the HDT48-00 Crimp Tool



Step 1:

Choose the correct AWG for the contact being used. (See chart).

Step 2:

Measure from the end of the wire **(A)** the recommended strip length according to the contact size. (See chart).

Step 3:

Place the wire into the stripping tool at the recommended strip length. Strip the wire according to the stripping tool instructions.

Step 4:

After stripping, a small piece of insulation should come off **(B)**.

Step 5:

Check for any broken strands or for a dent in the wire. If either exist, the wire is damaged and should be cut and stripped again.

Step 6:

Measure the exposed strands to be sure the crimp length is correct **(C)**.

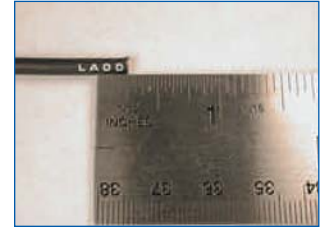

A

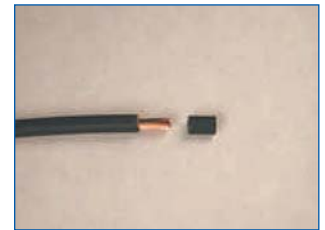

B

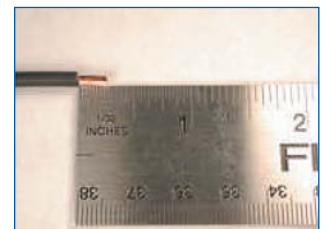

C

Solid Contacts

Contact Part Number	Size & Type	Wire Gauge Range	Recommended Strip Length	Hand Crimp Tool	Production Crimp Tool
0460-202-20141	20 Pin	20 & 24 AWG (0.5 - 0.2mm ²)	.156 - .218 (3.96 - 5.54mm)	HDT-48-00	HDP-400
0462-201-20141	20 Socket	20 & 24 AWG (0.5 - 0.2mm ²)	.156 - .218 (3.96 - 5.54mm)	HDT-48-00	HDP-400
0460-202-16141	16 Pin	16, 18 & 20 AWG (1.0 - 0.5mm ²)	.250 - .312 (6.35 - 7.92mm)	HDT-48-00	HDP-400
0462-201-16141	16 Socket	16, 18 & 20 AWG (1.0 - 0.5mm ²)	.250 - .312 (6.35 - 7.92mm)	HDT-48-00	HDP-400
0460-215-16141	16 Pin	14 & 16 AWG (2.0 - 1.0mm ²)	.250 - .312 (6.35 - 7.92mm)	HDT-48-00	HDP-400
0462-209-16141	16 Socket	14 & 16 AWG (2.0 - 1.0mm ²)	.250 - .312 (6.35 - 7.92mm)	HDT-48-00	HDP-400
0460-204-12141	12 Pin	12 & 14 AWG (3.0 - 2.0mm ²)	.222 - .284 (5.64 - 7.21mm)	HDT-48-00	HDP-400
0462-203-12141	12 Socket	12 & 14 AWG (3.0 - 2.0mm ²)	.222 - .284 (5.64 - 7.21mm)	HDT-48-00	HDP-400
0460-204-08141	8 Pin	8 & 10 AWG (8.0 - 5.0mm ²)	.430 - .492 (10.9 - 12.5mm)	HDT-04-08	HDP-400
0462-203-08141	8 Socket	8 & 10 AWG (8.0 - 5.0mm ²)	.430 - .492 (10.9 - 12.5mm)	HDT-04-08	HDP-400
0460-204-0490	4 Pin	6 AWG (13.0mm ²)	.430 - .492 (10.9 - 12.5mm)	HDT-04-08	HDP-400
0462-203-04141	4 Socket	6 AWG (13.0mm ²)	.430 - .492 (10.9 - 12.5mm)	HDT-04-08	HDP-400

How to Crimp

with the HDT48-00 Hand Tool

Step 1:

Strip insulation from wire.

Please refer to the instructions 'How to Strip a Wire for the HDT48-00 Crimp Tool' on page 9.

Step 2:

Raise selector knob and rotate until arrow is aligned with **wire gauge** to be crimped. **(A)**.

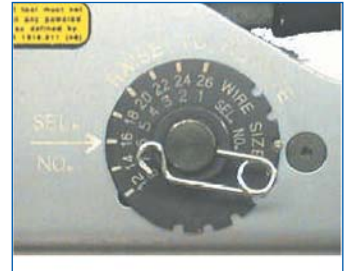

A

Step 3:

Loosen lock nut, turn adjusting screw in until it stops. **(B)**.

Step 4:

Insert contact (**See C for insertion point**), turn adjusting screw clockwise out until contact is flush or a bit above flush with indenter cover. Tighten lock nut.

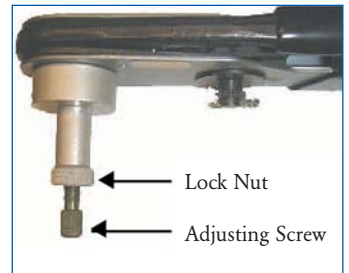

B

Step 5:

Insert wire in contact **(D)**. Contact must be centered between indicators. Close handles until the handles stop.

Step 6:

Release handles and remove crimped contact.

Step 7:

When completed, correct assembly can be checked visually. The removed insulation should expose a conductor length that will pass beyond the inspection hole in the contact. There should be about .025" to .100" of conductor between the contact and the insulation of the wire.

The following should be checked for after crimping:

1. Damaged wire strands.
2. Missing wire strands.
3. Wire strands not entering the contact barrel or splayed wires.
4. Wire not inserted to the correct depth in the contact, i.e. not visible through inspection hole.

If any of the above conditions exist, please discard the contact, re-cut and strip the wire and start the crimping process over.

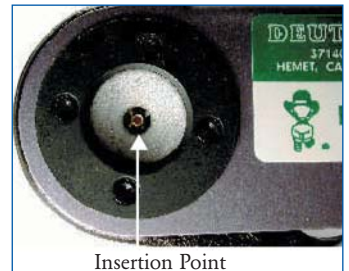

Insertion Point

C



D

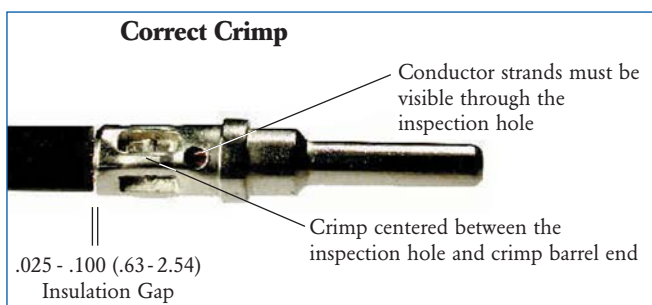

Stamped & Formed Contacts

The Deutsch range of Stamped & Formed contacts are designed primarily for use where wire termination costs are of primary concern without sacrificing the reliability and maintainability of the normal operating electrical circuits.

Design and Materials Selection

Deutsch engineers have combined the process of superior material selection with outstanding mechanical Cad-Cam Designs to present stamped & formed contacts that exceed the demands of today's truck, bus and off-highway electrical systems.

The selection of copper alloys, finished after forming with nickel plating

provides superior durability, performance, corrosion and oxidation resistance.

To achieve air-tight crimps that eliminate the need to solder after wire terminations, Deutsch engineers have specified that the core-wing ends be formed in the direction of the crimp, thus assuring resistance to crimp relaxation and displacement of metal, crimp after crimp.

True to all Deutsch terminals, the split socket (female) tines, protected by a closed entry stainless steel sleeve, ensure controlled contact pressure for maximum conductivity with minimum surface wear.

In keeping with the Deutsch commitment to quality, all stamped & formed contacts are manufactured using SPC controls and are subjected to extensive programs of rigid testing, including field performance feedback.

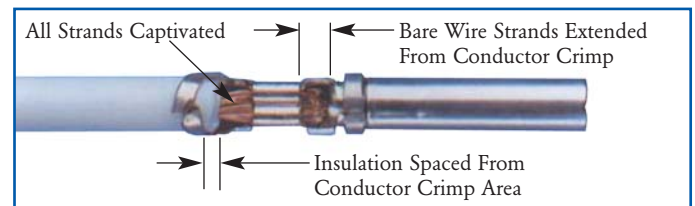
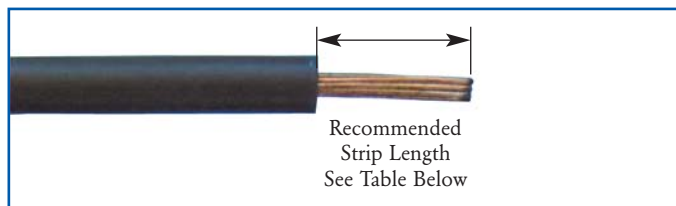

Features

Benefits

Stainless Steel Socket Sleeve	Provides closed entry design preventing probe damage.
Contact Tines are in Socket Member, Not Pin	Terminal contact points are protected from handling and assembly damage.
No Lances / Tangs	Contact retention is designed in the connector body, eliminating retention problems during handling and rework.
Bullet (Rounded) Pin Nose	Prevents mismatching and bent pins.
Nickel Plating	Reduces oxidations, thus improving conductivity performance.
Plated After Forming	No base metal is exposed to corrosion.
Optional Gold Plating	Available for dry circuit application.
No Individual wire Seal Grommets	Wire seals are designed as an integral component of the connector, thus reducing wire terminating costs.
Pre-Bent Core Wings	Provides an air-tight crimp joint.
Improved Die Stop Gap	Allows application die to position wire for proper crimp length.
Off-Set Configuration	Provides centre wire alignment between conductor and insulation.
Copper Alloy Materials	Prevents material relaxation over time, providing reliable crimp joints and increased durability

Stamped & Formed Contacts

Contact Part Number	Size & Type	Wire Gauge Range	Insulation O.D.	Recommended Strip Length	Hand Crimp Tool	Production Crimp Tool
1060-20-0122	20 Pin	16, 18 & 20 AWG (1.0-0.5mm ²)	0.075-0.125 (1.90-3.15mm)	.150-2.00 (3.81-5.08mm)	DTT-20-00	DCT20-02-00
1060-20-0122	20 Socket	16, 18 & 20 AWG (1.0-0.5mm ²)	0.075-0.125 (1.90-3.15mm)	.150-2.00 (3.81-5.08mm)	DTT-20-00	DCT20-02-00
1060-20-0222	20 Pin	16, 18 & 20 AWG (1.0-0.5mm ²)	0.050-0.085 (1.3-2.15mm)	.150-2.00 (3.81-5.08mm)	DTT-20-00	DCT20-02-00
1060-20-0222	20 Socket	16, 18 & 20 AWG (1.0-0.5mm ²)	0.050-0.085 (1.3-2.15mm)	.150-2.00 (3.81-5.08mm)	DTT-20-00	DCT20-02-00
1060-16-0622	16 Pin	16, 18 & 20 AWG (0.50-1.0mm ²)	.055-.083 (1.40-2.10mm)	.150-2.00 (3.81-5.08mm)	DTT-16-00	DCT16-02-00
1060-16-0622	16 Socket	16, 18 & 20 AWG (0.50-1.0mm ²)	.055-.083 (1.40-2.10mm)	.150-2.00 (3.81-5.08mm)	DTT-16-00	DCT16-02-00
1060-16-0122	16 Pin	16 & 18 AWG (0.75-1.5mm ²)	.075-0.115 (1.90-2.92mm)	.150-2.00 (3.81-5.08mm)	DTT-16-00	DCT16-02-00
1060-16-0122	16 Socket	16 & 18 AWG (0.75-1.5mm ²)	.075-0.115 (1.90-2.92mm)	.150-2.00 (3.81-5.08mm)	DTT-16-00	DCT16-02-00
1060-14-0122	16 Pin	14 & 16 AWG (2.0-1.0mm ²)	.095-0.150 (2.41-3.81mm)	.150-2.00 (3.81-5.08mm)	DTT-16-00	DCT16-02-00
1060-14-0122	16 Socket	14 & 16 AWG (2.0-1.0mm ²)	.095-0.150 (2.41-3.81mm)	.150-2.00 (3.81-5.08mm)	DTT-16-00	DCT16-02-00
1060-12-0166	12 Pin	12 & 14 AWG (4.0-2.0mm ²)	.113-0.170 (2.87-4.32mm)	.225-.275 (5.72-6.99mm)	DTT-12-00	DCT12-02-00
1060-12-0166	12 Socket	12 & 14 AWG (4.0-2.0mm ²)	.113-0.170 (2.87-4.32mm)	.225-.275 (5.72-6.99mm)	DTT-12-00	DCT12-02-00

DEUTSCH DISTRIBUTION NETWORK

Contact your local distribution outlet for sales and further information:



AUSTRALIA
EP&DE
401a Lal Lal Street
Ballarat, VIC 3350
AUSTRALIA
Tel: +61 3 5331 4700



GERMANY
Compagnie Deutsch GMBH
Fraunhoferstrabe.11b
82152 Martinsried
GERMANY
Tel: +49 89 89 91 570



ISRAEL
Deutsch ECM
P.O. Box 5010
Ashkelon 78150
Southern Industrial Zone
ISRAEL
Tel: +972 8 671 0903



ITALY
Deutsch Italia
9 Piazzale Lugano
20158 Milano
ITALY
Tel: +39 0239 322 240



JAPAN
Deutsch Japan Ltd.
44-10 Ohyamakanai-cho
Itabashi-ku
Tokyo 173-0024
JAPAN
Tel: +81 3 5995 5192



UNITED KINGDOM
Deutsch UK
Stanier Road
St Leonards on Sea
East Sussex TN38 9RF
UK
Tel: +44 (0) 1424 852722



USA
Deutsch IPD
3850 Industrial Ave
Hemet CA 92545
USA
Tel: +1 951 765 2250



Stanier Road, St Leonards on Sea
East Sussex TN38 9RF UK
Tel: +44 (0) 1424 852722
Fax: +44 (0) 1424 855979
Email: waterproof@deutsch.net
www.deutsch.net

SB1K08