

LM1247

150 MHz I²C Compatible RGB Preamp with Internal 512 Character OSD ROM, 512 Character RAM and 4 DACs

General Description

The LM1247 pre-amp is an integrated CMOS CRT preamp. It has an I²C compatible interface which allows control of all the parameters necessary to directly setup and adjust the gain and contrast in the CRT display. Brightness and bias can be controlled through the DAC outputs which are well matched to the LM2479 and LM2480 integrated bias clamp ICs. The LM1247 preamp is also designed to be compatible with the LM246x high gain driver family.

Black level clamping of the video signal is carried out directly on the AC coupled input signal into the high impedance preamplifier input, thus eliminating the need for additional clamp capacitors. Horizontal and vertical blanking of the outputs is provided. Vertical blanking is optional and its duration is register programmable.

The IC is packaged in an industry standard 24 lead DIP molded plastic package.

Features

- Internal 512 character OSD ROM usable as either (a) 384 2-color plus 128 4-color characters, (b) 640 2-color characters, or (c) some combination in between
- Internal 512 character RAM, which can be displayed as one single or two independent windows

- I²C compatible microcontroller interface
- OSD override allows OSD messages to override video and the use of burn-in screens with no video input
- 4 DAC outputs (8-bit resolution) for bus controlled CRT bias and brightness
- Spot killer which blanks the video outputs when V_{CC} falls below the specified threshold
- Suitable for use with discrete or integrated clamp, with software configurable brightness mixer
- Horizontal blanking and OSD synchronization directly from deflection signals. The blanking can be disabled, if desired
- Vertical blanking and OSD synchronization directly from deflection signals. The blanking width is register programmable and can be disabled, if desired
- Power Saving Mode with 65% power reduction
- Matched to LM246x driver and LM2479/80 bias IC's

Applications

- Low end 15" and 17" bus controlled monitors with OSD
- 1024x768 displays up to 85 Hz requiring OSD capability
- Very low cost systems with LM246x driver

Internal Block Diagram

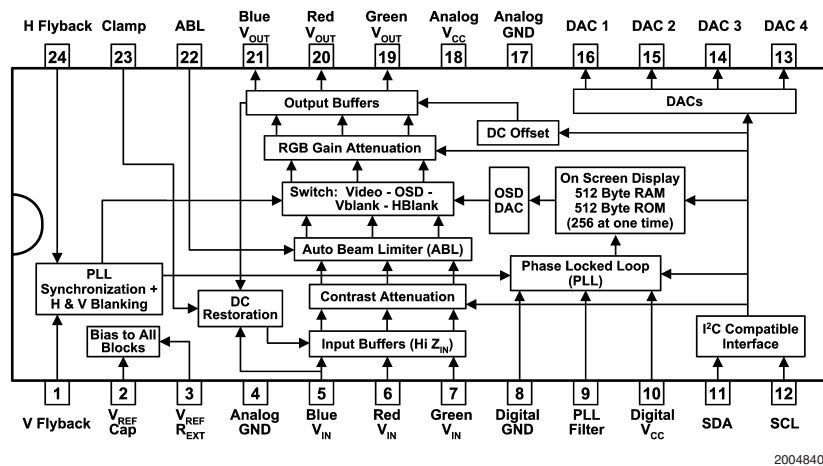

FIGURE 1. Order Number LM1247AAG/NA
See NS Package Number N24D

Absolute Maximum Ratings (Notes 1, 3)

If Military/Aerospace specified devices are required, please contact the National Semiconductor Sales Office/ Distributors for availability and specifications.

Supply Voltage V_{CC} , Pins 10 and 18	6.0V	ESD Susceptibility (Note 4)	3.0 kV
Peak Video DC Output Source Current (Any One Amp) Pins 19, 20 or 21	1.5 mA	ESD Machine Model (Note 13)	350V
Voltage at Any Input Pin (V_{IN})	$V_{CC} + 0.5 \geq V_{IN} \geq -0.5V$	Storage Temperature	$-65^{\circ}C$ to $+150^{\circ}C$
Video Inputs (pk-pk)	$0.0 \leq V_{IN} \leq 1.2V$	Lead Temperature (Soldering, 10 sec.)	$265^{\circ}C$
Thermal Resistance to Ambient (θ_{JA})	$51^{\circ}C/W$	Operating Ratings (Note 2)	
Power Dissipation (P_D) (Above $25^{\circ}C$ Derate Based on θ_{JA} and T_J)	2.4W	Temperature Range	$0^{\circ}C$ to $+70^{\circ}C$
Thermal Resistance to case (θ_{JC})	$32^{\circ}C/W$	Supply Voltage V_{CC}	$4.75V \leq V_{CC} \leq 5.25V$
Junction Temperature (T_J)	$150^{\circ}C$	Video Inputs (pk-pk)	$0.0V \leq V_{IN} \leq 1.0V$

Video Signal Electrical Characteristics

Unless otherwise noted: $T_A = 25^{\circ}C$, $V_{CC} = +5.0V$, $V_{IN} = 0.70 V_{P-P}$, $V_{ABL} = V_{CC}$, $C_L = 8$ pF, Video Outputs = $2.0 V_{P-P}$. Setting numbers refer to the definitions in *Table 1*. See (Note 7) for Min and Max parameters and (Note 6) for Typicals.

Symbol	Parameter	Conditions	Min	Typ	Max	Units
I_S	Supply Current	Test Setting 1, both supplies, no output loading. See (Note 8).		195	250	mA
I_{S-PS}	Supply Current, Power Save Mode	Test Setting 1, both supplies, no output loading. See (Note 8).		55	85	mA
$V_{O\ BLK}$	Active Video Black Level Output Voltage	Test Setting 4, no AC input signal, DC offset (register 0x8438 set to 0xd5).		1.2		VDC
$V_{O\ BLK\ STEP}$	Active Video Black Level Step Size	Test Setting 4, no AC input signal.		100		mVDC
$V_O\ Max$	Maximum Video Output Voltage	Test Setting 3, Video in = $0.70 V_{P-P}$	4.0	4.3		V
LE	Linearity Error	Test Setting 4, staircase input signal (see (Note 9)).		5		%
t_r	Video Rise Time	(Note 5), 10% to 90%, Test Setting 4, AC input signal.		3.1		ns
OS_R	Rising Edge Overshoot	(Note 5), Test Setting 4, AC input signal.		2		%
t_f	Video Fall Time	(Note 5), 90% to 10%, Test Setting 4, AC input signal.		2.9		ns
OS_F	Falling Edge Overshoot	(Note 5), Test Setting 4, AC input signal.		2		%
BW	Channel bandwidth (-3 dB)	(Note 5), Test Setting 4, AC input signal.		150		MHz
$V_{SEP\ 10\ kHz}$	Video Amplifier 10 kHz Isolation	(Note 14), Test Setting 8.		-60		dB
$V_{SEP\ 10\ MHz}$	Video Amplifier 10 MHz Isolation	(Note 14), Test Setting 8.		-50		dB
$A_V\ Max$	Maximum Voltage Gain	Test Setting 8, AC input signal.	3.8	4.1		V/V
$A_V\ C-50\%$	Contrast Attenuation @ 50%	Test Setting 5, AC input signal.		-5.2		dB
$A_V\ Min/A_V\ Max$	Maximum Contrast Attenuation (dB)	Test Setting 2, AC input signal.		-20		dB
$A_V\ G-50\%$	Gain Attenuation @ 50%	Test Setting 6, AC input signal.		-4.0		dB
$A_V\ G-Min$	Maximum Gain Attenuation	Test Setting 7, AC input signal.		-11		dB
$A_V\ Match$	Maximum Gain Match between channels	Test Setting 3, AC input signal.		± 0.5		dB
$A_V\ Track$	Gain Change between channels	Tracking when changing from Test Setting 8 to Test Setting 5. See (Note 11).		± 0.5		dB

Video Signal Electrical Characteristics (Continued)

Unless otherwise noted: $T_A = 25^\circ\text{C}$, $V_{CC} = +5.0\text{V}$, $V_{IN} = 0.70 V_{P-P}$, $V_{ABL} = V_{CC}$, $C_L = 8 \text{ pF}$, Video Outputs = $2.0 V_{P-P}$. Setting numbers refer to the definitions in *Table 1*. See (Note 7) for Min and Max parameters and (Note 6) for Typical.

Symbol	Parameter	Conditions	Min	Typ	Max	Units
$V_{ABL \text{ TH}}$	ABL Control Range upper limit	(Note 12), Test Setting 4, AC input signal.		4.8		V
$V_{ABL \text{ Range}}$	ABL Gain Reduction Range	(Note 12), Test Setting 4, AC input signal.		2.8		V
$A_{V \ 3.5}/A_{V \ \text{Max}}$	ABL Gain Reduction at 3.5V	(Note 12), Test Setting 4, AC input signal. $V_{ABL} = 3.5\text{V}$		-2		dB
$A_{V \ 2.0}/A_{V \ \text{Max}}$	ABL Gain Reduction at 2.0V	(Note 12), Test Setting 4, AC input signal. $V_{ABL} = 2.0\text{V}$		-12		dB
$I_{ABL \text{ Active}}$	ABL Input bias current during ABL	(Note 12), Test Setting 4, AC input signal. $V_{ABL} = V_{ABL \text{ MIN GAIN}}$			10	μA
$I_{ABL \text{ Max}}$	ABL input current sink capability	(Note 12), Test Setting 4, AC input signal.			1.0	mA
$V_{ABL \text{ Max}}$	Maximum ABL Input voltage during clamping	(Note 12), Test Setting 4, AC input signal. $I_{ABL} = I_{ABL \text{ MAX}}$			$V_{CC} + 0.1$	V
$A_V \text{ ABL Track}$	ABL Gain Tracking Error	(Note 9), Test Setting 4, $0.7 V_{P-P}$ input signal, ABL voltage set to 4.5V and 2.5V.			4.5	%
R_{IP}	Minimum Input resistance (pins 5, 6, 7)	Test Setting 4.		20		$\text{M}\Omega$

OSD Electrical Characteristics

Unless otherwise noted: $T_A = 25^\circ\text{C}$, $V_{CC} = +5.0\text{V}$. See (Note 7) for Min and Max parameters and (Note 6) for Typical.

Symbol	Parameter	Conditions	Min	Typ	Max	Units
$V_{OSD \text{ HIGH max}}$	Maximum OSD Level with OSD Contrast 11	Palette Set at 111, OSD Contrast = 11, Test Setting 3		4.5		V
$V_{OSD \text{ HIGH 10}}$	Maximum OSD Level with OSD Contrast 10	Palette Set at 111, OSD Contrast = 10, Test Setting 3		3.9		V
$V_{OSD \text{ HIGH 01}}$	Maximum OSD Level with OSD Contrast 01	Palette Set at 111, OSD Contrast = 01, Test Setting 3		3.2		V
$V_{OSD \text{ HIGH 00}}$	Maximum OSD Level with OSD Contrast 00	Palette Set at 111, OSD Contrast = 00, Test Setting 3		2.4		V
$\Delta V_{OSD} \text{ (Black)}$	Difference between OSD Black Level and Video Black Level (same channel)	Register 08=0x18, Input Video = Black, Same Channel, Test Setting 8		20		mV
$\Delta V_{OSD} \text{ (White)}$	Output Match between Channels	Palette Set at 111, OSD Contrast = 11, Maximum difference between R, G and B		3		%
$V_{OSD \text{-out (Track)}}$	Output Variation between Channels	OSD contrast varied from max to min		3		%

DAC Output Electrical Characteristics

Unless otherwise noted: $T_A = 25^\circ\text{C}$, $V_{CC} = +5.0\text{V}$, $V_{IN} = 0.7\text{V}$, $V_{ABL} = V_{CC}$, $C_L = 8 \text{ pF}$, Video Outputs = $2.0 V_{P-P}$. See (Note 7) for Min and Max parameters and (Note 6) for Typical. DAC parameters apply to all 4 DACs.

Symbol	Parameter	Conditions	Min	Typ	Max	Units
$V_{\text{Min DAC}}$	Min output voltage of DAC	Register Value = 0x00		0.5	0.7	V
$V_{\text{Max DAC Mode 00}}$	Max output voltage of DAC	Register Value = 0xFF, DCF[1:0] = 00b	3.7	4.2		V
$V_{\text{Max DAC Mode 01}}$	Max output voltage of DAC in DCF mode 01	Register Value = 0xFF, DCF[1:0] = 01b	1.85	2.35		V

DAC Output Electrical Characteristics (Continued)

Unless otherwise noted: $T_A = 25^\circ\text{C}$, $V_{CC} = +5.0\text{V}$, $V_{IN} = 0.7\text{V}$, $V_{ABL} = V_{CC}$, $C_L = 8\text{ pF}$, Video Outputs = 2.0 V_{P-P} . See (Note 7) for Min and Max parameters and (Note 6) for Typicals. DAC parameters apply to all 4 DACs.

Symbol	Parameter	Conditions	Min	Typ	Max	Units
$\Delta V_{\text{Max DAC}}$ (Temp)	Variation in voltage of DAC with temperature	$0 < T < 70^\circ\text{C}$ ambient		± 0.5		mV/ $^\circ\text{C}$
$\Delta V_{\text{Max DAC}}(V_{CC})$	DAC output voltage variation with V_{CC}	V_{CC} varied from 4.75V to 5.25V, DAC register set to mid-range (0x7F)		50		mV
Linearity	Linearity of DAC over its range			5		%
Monotonicity	Monotonicity of the DAC Excluding dead zones			± 0.5		LSB
I_{MAX}	Max Load Current		-1.0		1.0	mA

System Interface Signal Characteristics

Unless otherwise noted: $T_A = 25^\circ\text{C}$, $V_{CC} = +5.0\text{V}$, $V_{IN} = 0.7\text{V}$, $V_{ABL} = V_{CC}$, $C_L = 8\text{ pF}$, Video Outputs = 2.0 V_{P-P} . See (Note 7) for Min and Max parameters and (Note 6) for Typicals. DAC parameters apply to all 4 DACs.

Symbol	Parameter	Conditions	Min	Typ	Max	Units
$V_{\text{VTH+}}$	VFLYBACK positive switching guarantee	Vertical Blanking triggered	2.0			V
V_{SPOT}	Spot Killer Voltage	(Note 17), V_{CC} Adjusted to Activate	3.4	3.9	4.3	V
V_{Ref}	V_{Ref} Output Voltage (pin 2)		1.25	1.45	1.65	V
V_{IL} (SCL, SDA)	Logic Low Input Voltage		-0.5		1.5	V
V_{IH} (SCL, SDA)	Logic High Input Voltage		3.0		$V_{CC} + 0.5$	V
I_{L} (SCL, SDA)	Logic Low Input Current	SDA or SCL, Input Voltage = 0.4V		± 10		μA
I_{H} (SCL, SDA)	Logic High Input Current	SDA or SCL, Input Voltage = 4.5V		± 10		μA
V_{OL} (SCL, SDA)	Logic Low Output Voltage	$I_O = 3\text{ mA}$		0.5		V
$f_{\text{H Min}}$	Minimum Horizontal Frequency	PLL & OSD Operational; PLL Range = 0		25		kHz
$f_{\text{H Max}}$	Maximum Horizontal Frequency	PLL & OSD Operational; PLL Range = 3		110		kHz
$I_{\text{HFB IN Max}}$	Horizontal Flyback Input	Current Absolute Maximum During Flyback			5	mA
I_{IN}	Peak Current during flyback	Design Value		4		mA
$I_{\text{HFB OUT Max}}$	Horizontal Flyback Input Current	Absolute Maximum During Scan	-700			μA
I_{OUT}	Peak Current during Scan	Not exact - Duty Cycle Dependent		-550		μA
$I_{\text{IN THRESHOLD}}$	I_{IN} H-Blank Detection Threshold			0		μA
$t_{\text{H-BLANK ON}}$	H-Blank Time Delay - On	+ Zero crossing of I_{HFB} to 50% of output blanking start. $I_{24} = +1.5\text{mA}$		45		ns
$t_{\text{H-BLANK OFF}}$	H-Blank Time Delay - Off	- Zero crossing of I_{HFB} to 50% of output blanking end. $I_{24} = -100\mu\text{A}$		85		ns
$V_{\text{BLANK Max}}$	Maximum Video Blanking Level	Test Setting 4, AC input signal	0		0.25	V
f_{FREERUN}	Free Run H Frequency, including H Blank			42		kHz
$t_{\text{PW CLAMP}}$	Minimum Clamp Pulse Width	See (Note 15)	200			ns
$V_{\text{CLAMP MAX}}$	Maximum Low Level Clamp Pulse Voltage	Video Clamp Functioning			2.0	V
$V_{\text{CLAMP MIN}}$	Minimum High Level Clamp Pulse Voltage	Video Clamp Functioning	3.0			V
$I_{\text{CLAMP Low}}$	Clamp Gate Low Input Current	$V_{23} = 2\text{V}$		-0.4		μA
$I_{\text{CLAMP High}}$	Clamp Gate High Input Current	$V_{23} = 3\text{V}$		0.4		μA
$t_{\text{CLAMP-VIDEO}}$	Time from End of Clamp Pulse to Start of Video	Referenced to Blue, Red and Green inputs	50			ns

System Interface Signal Characteristics (Continued)

- Note 1:** Limits of Absolute Maximum Ratings indicate below which damage to the device must not occur.
- Note 2:** Operating ratings indicate conditions for which the device is functional, but do not guarantee specific performance limits.
- Note 3:** All voltages are measured with respect to GND, unless otherwise specified.
- Note 4:** Human body model, 100 pF discharged through a 1.5 kΩ resistor.
- Note 5:** Input from signal generator: $t_r, t_f < 1$ ns.
- Note 6:** Typical specifications are specified at +25°C and represent the most likely parametric norm.
- Note 7:** Datasheet min/max specification limits are guaranteed by design, test, or statistical analysis. The guaranteed specifications apply only for the test conditions listed. Some performance characteristics may change when the device is not operated under the listed test conditions.
- Note 8:** The supply current specified is the quiescent current for V_{CC} and 5V Dig with $R_L = \infty$. Load resistors are not required and are not used in the test circuit, therefore all the supply current is used by the pre-amp.
- Note 9:** Linearity Error is the maximum variation in step height of a 16 step staircase input signal waveform with a 0.7 V_{P-P} level at the input. All 16 steps equal, with each at least 100 ns in duration.
- Note 10:** $dt/dV_{CC} = 200 * (t_{5.5V} - t_{4.5V}) / ((t_{5.5V} + t_{4.5V}) \%V$, where: $t_{5.5V}$ is the rise or fall time at $V_{CC} = 5.5V$, and $t_{4.5V}$ is the rise or fall time at $V_{CC} = 4.5V$.
- Note 11:** ΔA_V track is a measure of the ability of any two amplifiers to track each other and quantifies the matching of the three gain stages. It is the difference in gain change between any two amplifiers with the contrast set to $A_V C - 50\%$ and measured relative to the A_V max condition. For example, at A_V max the three amplifiers' gains might be 12.1 dB, 11.9 dB, and 11.8 dB and change to 2.2 dB, 1.9 dB and 1.7 dB respectively for contrast set to $A_V C - 50\%$. This yields a typical gain change of 10.0 dB with a tracking change of ± 0.2 dB.
- Note 12:** The ABL input provides smooth decrease in gain over the operational range of 0 dB to -5 dB: $\Delta A_{ABL} = A(V_{ABL} = V_{ABL \text{ MAX GAIN}}) - A(V_{ABL} = V_{ABL \text{ MIN GAIN}})$. Beyond -5 dB the gain characteristics, linearity and pulse response may depart from normal values.
- Note 13:** Machine Model ESD test is covered by specification EIAJ IC-121-1981. A 200 pF cap is charged to the specific voltage, then discharged directly into the IC with no external series resistor (resistance of discharge path must be under 50Ω).
- Note 14:** Measure output levels of the other two undriven amplifiers relative to the driven amplifier to determine channel separation. Terminate the undriven amplifier inputs to simulate generator loading. Repeat test at $f_{IN} = 10$ MHz for V_{SEP} 10 MHz.
- Note 15:** A minimum pulse width of 200 ns is the guaranteed minimum for a horizontal line of 15 kHz. This limit is guaranteed by design. If a lower line rate is used then a longer clamp pulse may be required.
- Note 16:** Adjust input frequency from 10 MHz (A_V max reference level) to the -3 dB corner frequency ($f_{-3 \text{ dB}}$).
- Note 17:** Once the spot killer has been activated, the LM1247 remains in the off state until V_{CC} is cycled (reduced below 0.5V and then restored to 5V).

Hexadecimal and Binary Notation

Hexadecimal numbers appear frequently throughout this document, representing slave and register addresses, and register values. These appear in the format "0x...". For example, the slave address for writing the registers of the LM1247 is hexadecimal BA, written as 0xBA. On the other hand, binary values, where the individual bit values are shown, are indicated by a trailing "b". For example, 0xBA is equal to 10111010b. A subset of bits within a register is referred to by the bit numbers in brackets following the

register value. For example, the OSD contrast bits are the fourth and fifth bits of register 0x8438. Since the first bit is bit 0, the OSD contrast register is 0x8438[4:3].

Register Test Settings

Table 1 shows the definitions of the Test Settings 1–8 referred to in the specifications sections. Each test setting is a combination of five hexadecimal register values, Contrast, Gain (Blue, Red, Green) and DC offset.

TABLE 1. Test Settings

Control	No. of Bits	Test Settings							
		1	2	3	4	5	6	7	8
Contrast	7	0x7F (Max)	0x00 Min	0x7F (Max)	0x7F (Max)	0x40 (50.4%)	0x7F (Max)	0x7F (Max)	0x7F (Max)
B, R, G Gain	7	0x7F (Max)	0x7F (Max)	0x7F (Max)	Set V_O to 2 V_{P-P}	0x7F (Max)	0x40 (50.4%)	0x00 (Min)	0x7F (Max)
DC Offset	3	0x00 (Min)	0x05	0x07 (Max)	0x05	0x05	0x05	0x05	0x05

LM1253A and LM1237 Compatibility

In order to maintain register compatibility with the LM1253A and LM1237 preamplifier datasheet assignments for bias and brightness, the color assignments are recommended as

shown in *Table 2*. If datasheet compatibility is not required, then the DAC assignments can be arbitrary.

TABLE 2. LM1253A/LM1237 Compatibility

	DAC Bias Outputs			
LM1247 Pin:	DAC 1	DAC 2	DAC 3	DAC 4
Assignment:	Blue	Green	Red	Brightness

OSD vs Video Intensity

The OSD amplitude has been increased over the LM1237 level. During monitor alignment, the three gain registers are used to achieve the desired front of screen color balance. This also causes the OSD channels to be adjusted accordingly, since these are inserted into the video channels prior to the gain attenuators. This provides the means to fine tune the intensity of the OSD relative to the video as follows. If a typical starting point for the alignment is to have the gains at maximum (0x7F) and the contrast at 0x55, the resultant OSD intensity will be higher than if the starting point is with the gains at 0x55 and the contrast at maximum (0x7F). This tradeoff allows fine tuning the final OSD intensity relative to the video. In addition, the OSD contrast register, 0x8438 [4:3], provides 4 major increments of intensity. Together, these allow setting the OSD intensity to the most pleasing level.

ESD Protection

The LM1247 features a 3.0 KV ESD protection level (see (Notes 4, 13)). This is provided by special internal circuitry which activates when the voltage at any pin goes beyond the supply rails by a preset amount. At that time the protection is applied to all pins, including SDA and SCL. If any signal other than these two is applied to the LM1247 while the V_{CC} is near zero, such as horizontal and vertical deflection pulses of sufficient amplitude, this protection will activate and prevent any communication on the I²C bus common to the LM1247, until the other signal or signals are removed. Normally, with all other pins unenergized, the LM1247 will not affect I²C communication when it is powered down.

Typical Performance Characteristics $V_{CC} = 5V, T_A = 25^\circ C$ unless otherwise specified

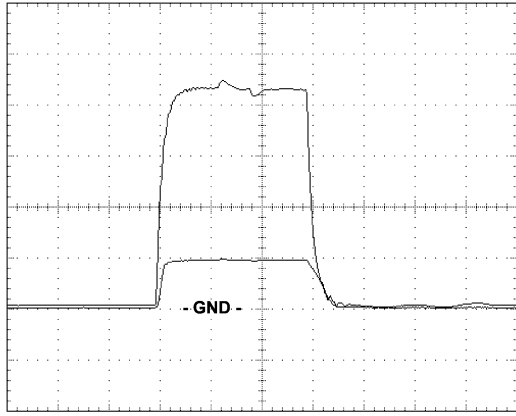

Horizontal: 500 nSec/div Vertical: 1 V/div (both)
20048402

FIGURE 2. Logic Horizontal Blanking

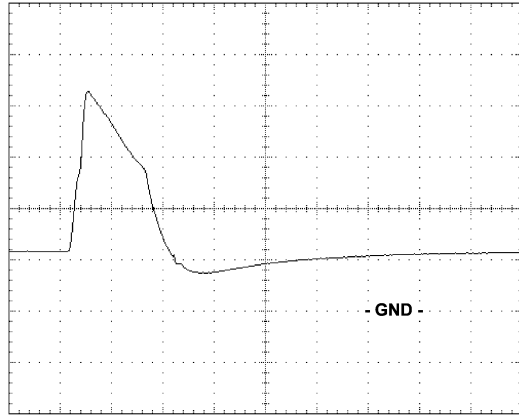

Horizontal: 100 µsec/div Vertical: 1 V/div
20048405

FIGURE 5. Deflection Vertical Blanking

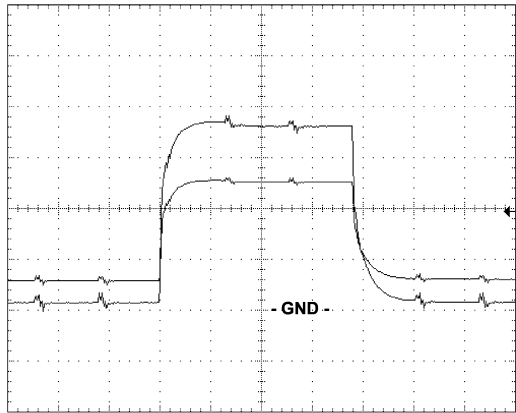

Horizontal: 10 µSec/div Vertical: 1 V/div (both)
20048403

FIGURE 3. Logic Vertical Blanking

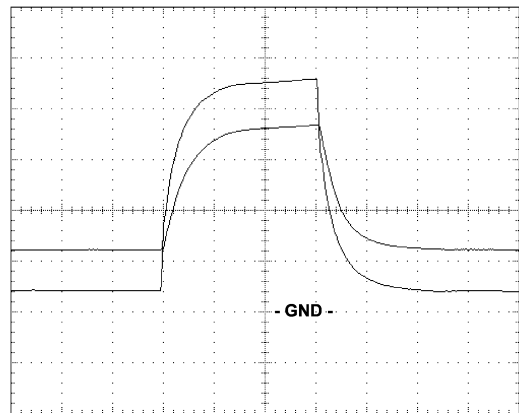

Horizontal: 100 nSec/div Vertical: 1 V/div (both)
20048406

FIGURE 6. Logic Clamp Pulse

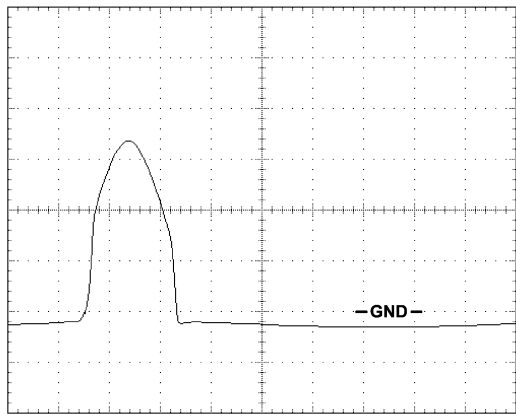

Horizontal: 1 µsec/div Vertical: 500 mV/div
20048404

FIGURE 4. Deflection Horizontal Blanking

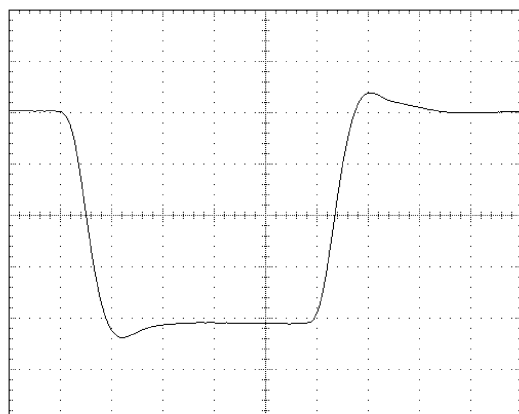

Horizontal: 12.5 nSec/div Vertical: 10 V/div
20048407

FIGURE 7. Red Cathode Response

Typical Performance Characteristics $V_{CC} = 5V$, $T_A = 25^\circ C$ unless otherwise specified (Continued)

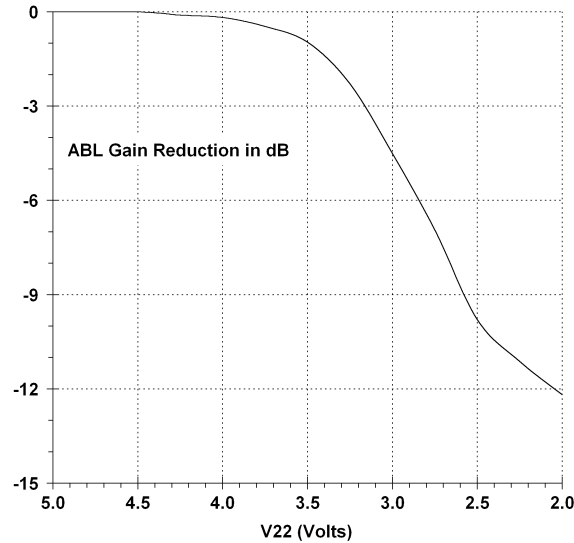

20048408

FIGURE 8. ABL Gain Reduction Curve

SYSTEM INTERFACE SIGNALS

The Horizontal and Vertical Blanking and the Clamping input signals are important for proper functionality of the LM1247. Both blanking inputs must be present for OSD synchronization. In addition, the Horizontal blanking input also assists in setting the proper cathode black level, along with the Clamping pulse. The Vertical blanking input initiates a blanking level at the LM1247 outputs which is programmable from 3 to 127 lines (we recommend at least 10). Both horizontal and vertical blanking can be individually disabled, if desired.

Figure 2 and Figure 3 show the case where the Horizontal and Vertical inputs are logic levels. Figure 2 shows the smaller pin 24 voltage superimposed on the horizontal blanking pulse input to the neck board with $R_H = 4.7k$ and $C_{17} = 0.1 \mu F$. Note where the voltage at pin 24 is clamped to about 1 volt when the pin is sinking current. Figure 3 shows the smaller pin 1 voltage superimposed on the vertical blanking input to the neck board with C_4 jumpered and $R_V = 4.7k$. These component values correspond to the application circuit of Figure 9.

Figure 4 and Figure 5 show the case where the horizontal and vertical inputs are from deflection. Figure 4 shows the pin 24 voltage which is derived from a horizontal flyback pulse of 35V peak to peak with $R_H = 8.2k$ and C_{17} jumpered. Figure 5 shows the pin 1 voltage which is derived from a vertical flyback pulse of 55V peak to peak with $C_4 = 1500 pF$ and $R_V = 120k$.

Figure 6 shows the pin 23 clamp input voltage superimposed on the neck board clamp logic input pulse. $R_{31} = 1k$ and should be chosen to limit the pin 23 voltage to about 2.5V peak to peak. This corresponds to the application circuit given in Figure 9.

CATHODE RESPONSE

Figure 7 shows the response at the red cathode for the application circuit in Figures 9, 10. The input video risetime is 1.5 ns. The resulting leading edge has a 7.1 ns risetime and a 7.6% overshoot, while the trailing edge has a 7.1 ns risetime and a 6.9% overshoot with an LM2467 driver.

ABL GAIN REDUCTION

The ABL function reduces the contrast level of the LM1247 as the voltage on pin 22 is lowered from V_{CC} to around 2V. Figure 8 shows the amount of gain reduction as the voltage is lowered from V_{CC} (5.0V) to 2V. The gain reduction is small until V_{22} reaches the knee around 3.7V, where the slope increases. Many system designs will require about 3 dB to 5 dB of gain reduction in full beam limiting. Additional attenuation is possible, and can be used in special circumstances. However, in this case, video performance such as video linearity and tracking between channels will tend to depart from normal specifications.

OSD PHASE LOCKED LOOP

Table 3 shows the recommended horizontal scan rate ranges (in kHz) for each combination of PLL register setting, 0x843E [1:0], and the pixels per line register setting, 0x8401 [7:5]. These ranges are recommended for chip ambient temperatures of 25°C to 70°C. While the OSD PLL will lock for other register combinations and at scan rates outside these ranges, the performance of the loop will be improved if these recommendations are followed. NR means the combination of PLL and PPL is not recommended for any scan rate.

Typical Performance Characteristics $V_{CC} = 5V, T_A = 25^\circ C$ unless otherwise specified (Continued)

TABLE 3. OSD Register recommendations

	PPL=0	PPL=1	PPL=2	PPL=3	PPL=4	PPL=5	PPL=6	PPL=7
PLL=1	25 - 61	25 - 53	25 - 48	25 - 43	25 - 40	25 - 36	25 - 34	25 - 31
PLL=2	NR	NR	48 - 98	43 - 88	40 - 81	36 - 74	34 - 69	31 - 64
PLL=3	NR	NR	NR	88 - 110	81 - 110	74 - 110	69 - 110	64 - 110

Pin Descriptions and Application Information

Pin No.	Pin Name	Schematic	Description
1	V Flyback	<p>* ESD Protection</p>	<p>Required for OSD synchronization and is also used for vertical blanking of the video outputs. The actual switching threshold is about 35% of V_{CC}. For logic level inputs C_4 can be a jumper, but for flyback inputs, an AC coupled differentiator is recommended, where R_V is large enough to prevent the voltage at pin 1 from exceeding V_{CC} or going below GND. C_4 should be small enough to flatten the vertical rate ramp at pin 1. C_{24} may be needed to reduce noise.</p>
2	V_{REF} Bypass	<p>* ESD Protection to pin 3</p>	<p>Provides filtering for the internal voltage which sets the internal bias current in conjunction with R_{EXT}. A minimum of 0.1 μF is recommended for proper filtering. This capacitor should be placed as close to pin 2 and the pin 4 ground return as possible.</p>
3	V_{REF}	<p>* ESD Protection to pin 2</p>	<p>External resistor, 10k 1%, sets the internal bias current level for optimum performance of the LM1247. This resistor should be placed as close to pin 3 and the pin 4 ground return as possible.</p>
4	Analog Input Ground	<p>GND (Analog)</p>	<p>This is the ground for the input analog portions of the LM1247 internal circuitry.</p>
5 6 7	Blue Video In Red Video In Green Video In	<p>* ESD Protection</p>	<p>These video inputs must be AC coupled with a .0047 μF cap. Internal DC restoration is done at these inputs. A series resistor of about 33Ω and external ESD protection diodes should also be used for protection from ESD damage.</p>

Pin Descriptions and Application Information (Continued)

Pin No.	Pin Name	Schematic	Description
8 10	Digital Ground PLL V_{CC}		The ground pin should be connected to the rest of the circuit ground by a short but independent PCB trace to prevent contamination by extraneous signals. The V_{CC} pin should be isolated from the rest of the V_{CC} line by a ferrite bead and bypassed to pin 8 with an electrolytic capacitor and a high frequency ceramic.
9	PLL Filter		Recommended topology and values are shown to the left. It is recommended that both filter branches be bypassed to the independent ground as close to pin 8 as possible. Great care should be taken to prevent external signals from coupling into this filter from video, I^2C , etc.
11	SDA	<p style="text-align: center;">* ESD Protection</p>	The I^2C compatible data line. A pull-up resistor of about 2 k Ω should be connected between this pin and V_{CC} . A resistor of at least 100 Ω should be connected in series with the data line for additional ESD protection.
12	SCL	<p style="text-align: center;">* ESD Protection</p>	The I^2C compatible clock line. A pull-up resistor of about 2 k Ω should be connected between this pin and V_{CC} . A resistor of at least 100 Ω should be connected in series with the clock line for additional ESD protection.
13 14 15 16	DAC 4 Output DAC 2 Output DAC 3 Output DAC 1 Output	<p style="text-align: center;">* ESD Protection</p>	DAC outputs for cathode cut-off adjustments and brightness control. DAC 4 can be set to change the outputs of the other three DACs, acting as a brightness control. The DAC values and the special DAC 4 function are set through the I^2C compatible bus. A resistor of at least 100 Ω should be connected in series with these outputs for additional ESD protection.
17 18	Ground V_{CC}		Ground pin for the output analog portion of the LM1247 circuitry, and power supply pin for all the analog of the LM1247. Note the recommended charge storage and high frequency capacitors which should be as close to pins 17 and 18 as possible.

Pin Descriptions and Application Information (Continued)

Pin No.	Pin Name	Schematic	Description
19 20 21	Green Output Red Output Blue Output	<p style="text-align: center;">* ESD Protection</p>	These are the three video output pins. They are intended to drive the LM246x family of cathode drivers. Nominally, about 2V peak to peak will produce 40V peak to peak of cathode drive.
22	ABL	<p style="text-align: center;">* ESD Protection</p>	The Automatic Beam Limiter input is biased to the desired beam current limit by R_{ABL} and V_{BB} and normally keeps D_{INT} forward biased. When the current resupplying the CRT capacitance (averaged by C_{ABL}) exceeds this limit, then D_{INT} begins to turn off and the voltage at pin 22 begins to drop. The LM1247 then lowers the gain of the three video channels until the beam current reaches an equilibrium value.
23	CLAMP	<p style="text-align: center;">* ESD Protection</p>	This pin accepts either TTL or CMOS logic levels. The internal switching threshold is approximately one-half of V_{CC} . An external series resistor, R_{31} , of about 1K is recommended to avoid overdriving the input devices. In any event, R_{EXT} must be large enough to prevent the voltage at pin 23 from going higher than V_{CC} or below GND.
24	H Flyback	<p style="text-align: center;">* ESD Protection</p>	Proper operation requires current reversal. R_H should be large enough to limit the peak current at pin 24 to about +4 ma during blanking, and $-500 \mu A$ during scan. C_{17} is usually needed for logic level inputs and should be large enough to make the time constant, $R_H C_{17}$ significantly larger than the horizontal period. R_{34} and C_8 are typically 300Ω and 330 pF when the flyback waveform has ringing and needs filtering. C_{18} may be needed to filter extraneous noise and can be up to 100 pF .

Schematic Diagram

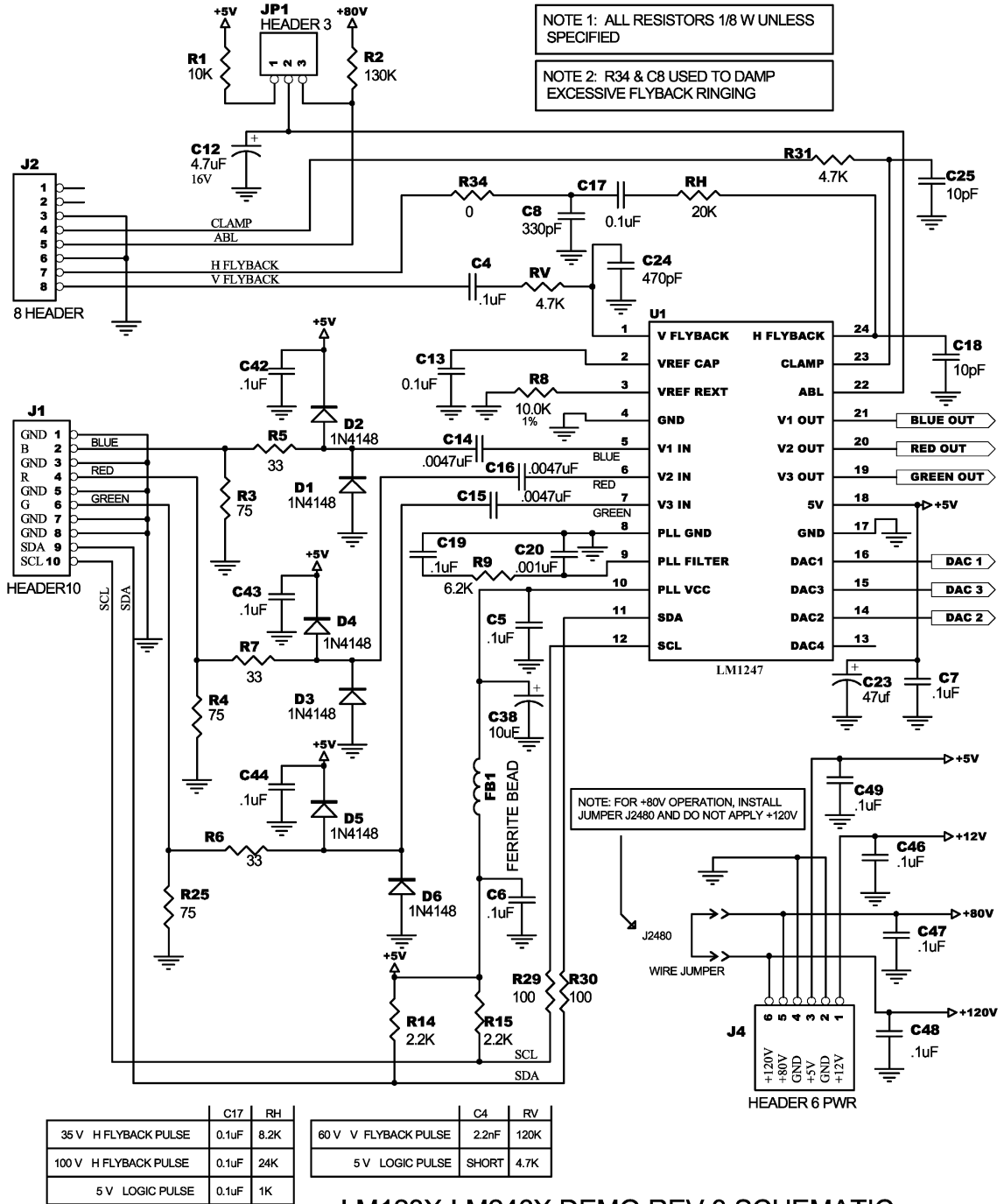

LM123X-LM246X DEMO REV 3 SCHEMATIC

20048424

FIGURE 9. LM123x/LM124x-LM246x Demo Board Schematic

Schematic Diagram

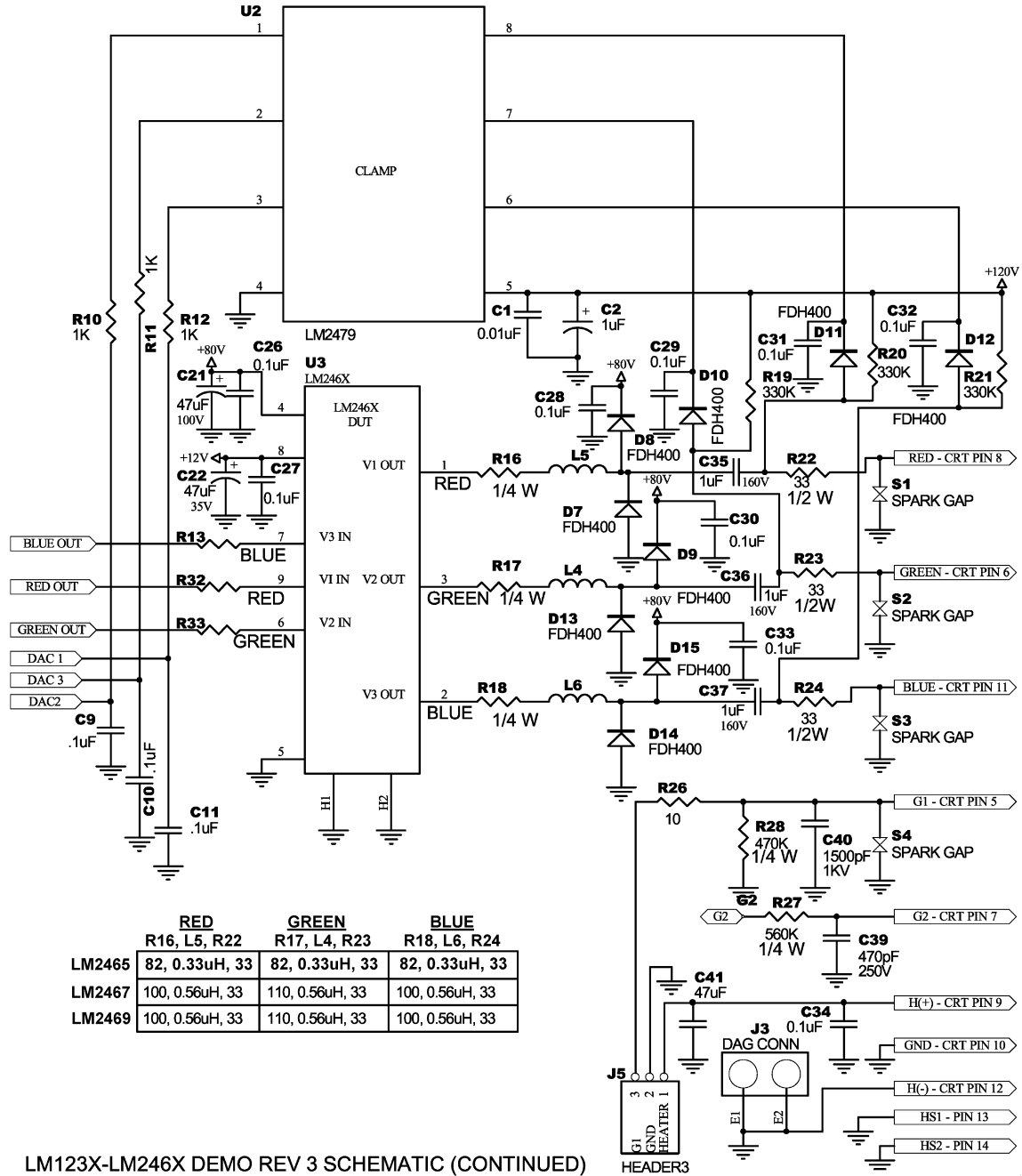

LM123X-LM246X DEMO REV 3 SCHEMATIC (CONTINUED)

20048425

FIGURE 10. LM123x/LM124x-LM246x Demo Board Schematic (continued)

PCB Layout

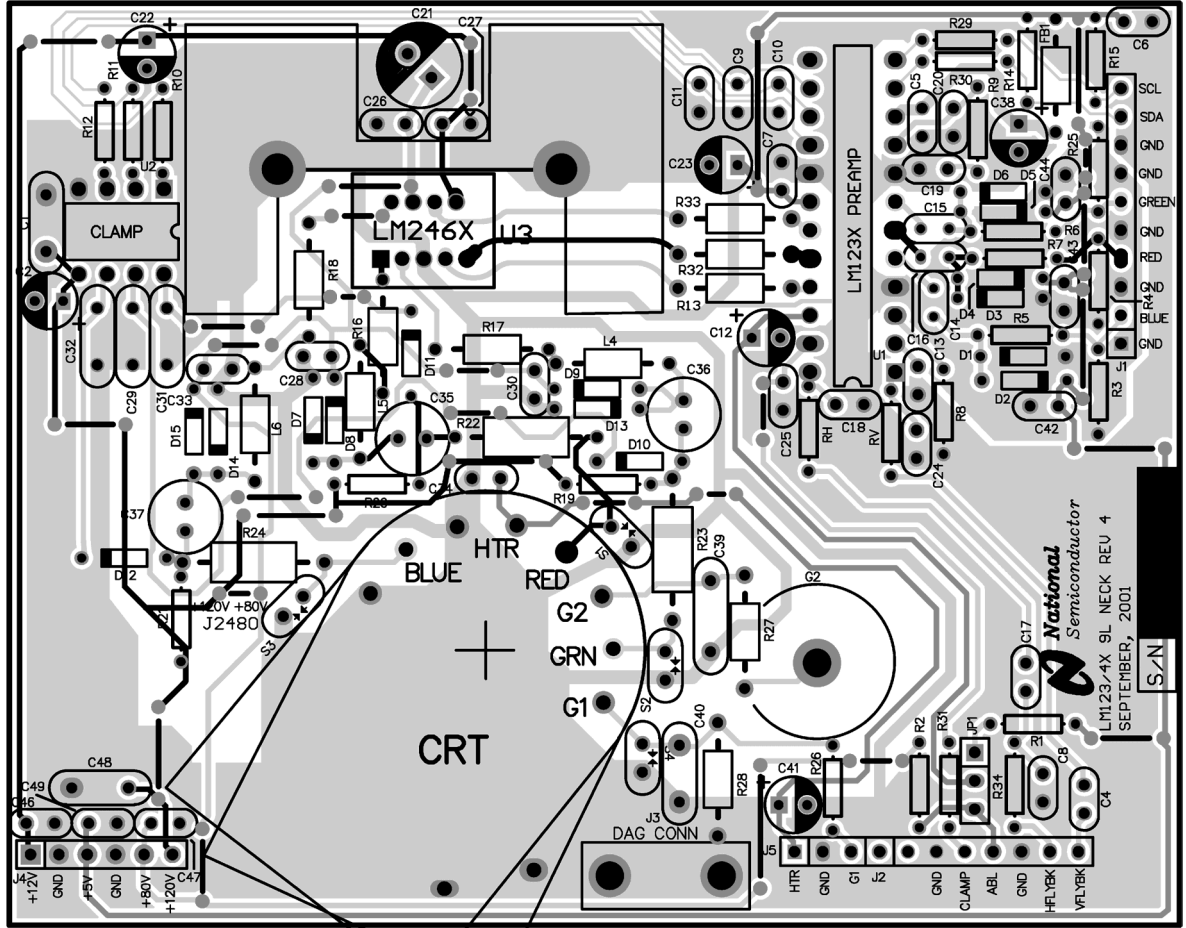

20048426

FIGURE 11. LM123x/LM124x-LM246x Demo Board Layout

OSD Generator Operation

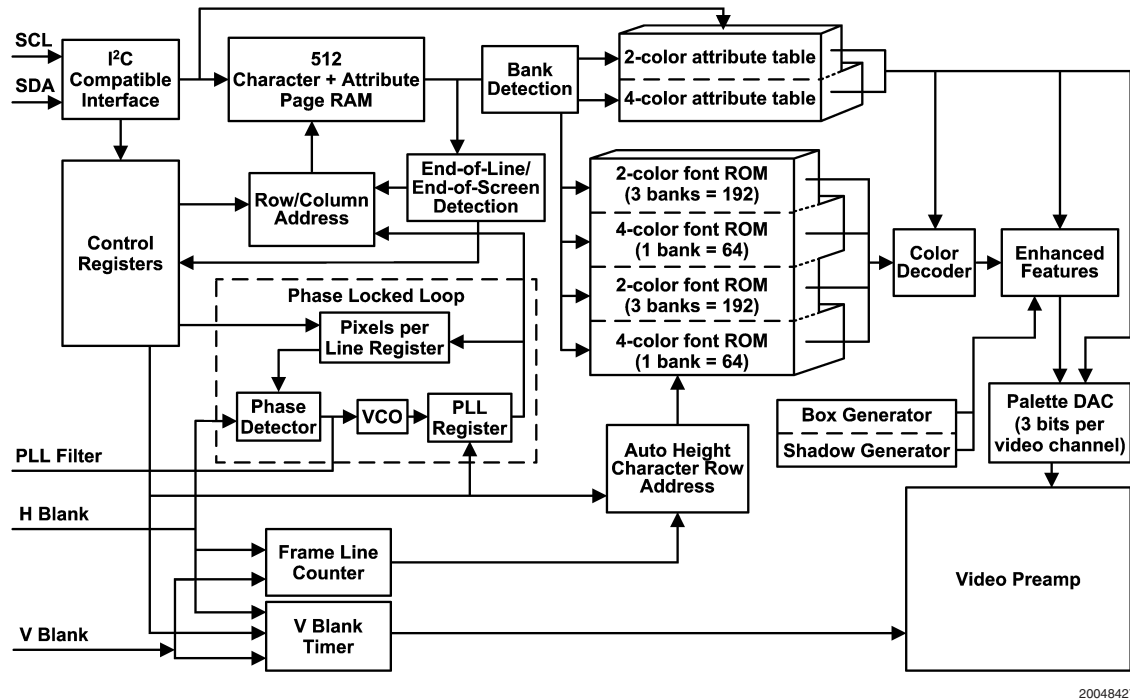

FIGURE 12. OSD Generator Block Diagram

PAGE OPERATION

Figure 12 shows the block diagram of the OSD generator. OSD screens are created using any of the 512 predefined characters stored in the mask programmed ROM. The OSD image is composed of up to 512 characters stored in page RAM, where each character has a unique 8-bit address. This means only half of the 512 ROM characters can be displayed at any one time. Since a 9 bit address is needed to select from 512 ROM addresses, a bank select register is used to convert the upper 2 bits of the character code into a 3 bit bank address which is combined with the other 6 bits to produce the necessary 9 bits. Also, since the lower 6 bits can address 64 characters, this gives a bank size of 64. Therefore, the ROM consists of 8 banks of 64 characters each, where 4 of these 8 banks are displayed by loading the 4 bank address registers with the appropriate 3 bit code. This allows the programmer to switch between two different OSD images, by simply reprogramming the bank addresses.

OSD ROM CONFIGURATION

The OSD ROM is equivalent to two 256 character ROMs of the type used in the LM1253A and LM1237. Because of the bank select method described earlier, each can be considered as a group of 3 banks (192) two-color characters followed by 1 bank (64) four-color characters. Physically, the combined ROM is then $192 \times 2 + 64 \times 4 + 192 \times 2 + 64 \times 4$. This is shown in Figure 12.

BANK ADDRESSING

A pictorial view of this addressing method is shown in Figure 13. On the left side is a section of the Page RAM with four different addresses in successive locations, which have been chosen to demonstrate accessing 4 of the 8 ROM banks using the Bank Select Registers. The first has 10b for

the two most significant bits, so the OSD generator looks in B2AD[2:0], located in Bank Select Register B, for its ROM bank address. Since B2AD[2:0] contains 101b, the character font is read from Bank 5. The complete font address is composed of this bank address, plus the lower six bits of the original byte in Page RAM, giving a ROM address of 101101110b. The remaining addresses demonstrate that the four selected banks can be displayed in any order.

END-OF-LINE AND END-OF-SCREEN CODES

There are two special character addresses used in the page RAM, 0x00 (End-of-Screen) and 0x01 (End-of-Line). The first must be used to terminate a window and the second to terminate a line. The LM1247 is different from the LM1253A and LM1237 in that these are now not actually encoded into ROM, but are instead detected by the logic as the OSD image is read from page RAM. This means that the two lowest locations in the bank which is currently selected by Bank Select Register 0, 0x8427[2:0], cannot be displayed in an OSD image. However, these two characters can be masked in the ROM, and if this bank is selected by Bank Select Registers 1, 2 or 3, then these two characters are usable on screen. The consequences of this is that only 254 ROM characters are displayable at one time.

DISPLAYING AN OSD IMAGE

Consecutive lines of characters make up the displayed window. These characters are stored in the page RAM through the I²C compatible bus. Each line can contain any number of characters up to the limit of the displayable line length (dependent on the pixels per line register), although some restrictions concerning the enhanced features apply on character lines longer than 32 characters. The number of characters across the width and height of the page can be

OSD Generator Operation (Continued)

varied under I²C compatible control, but the total number of characters that can be stored and displayed on the screen is

limited to 512 including any End-of-Line and End-of-Screen characters. The horizontal and vertical start position can also be programmed through the I²C compatible bus.

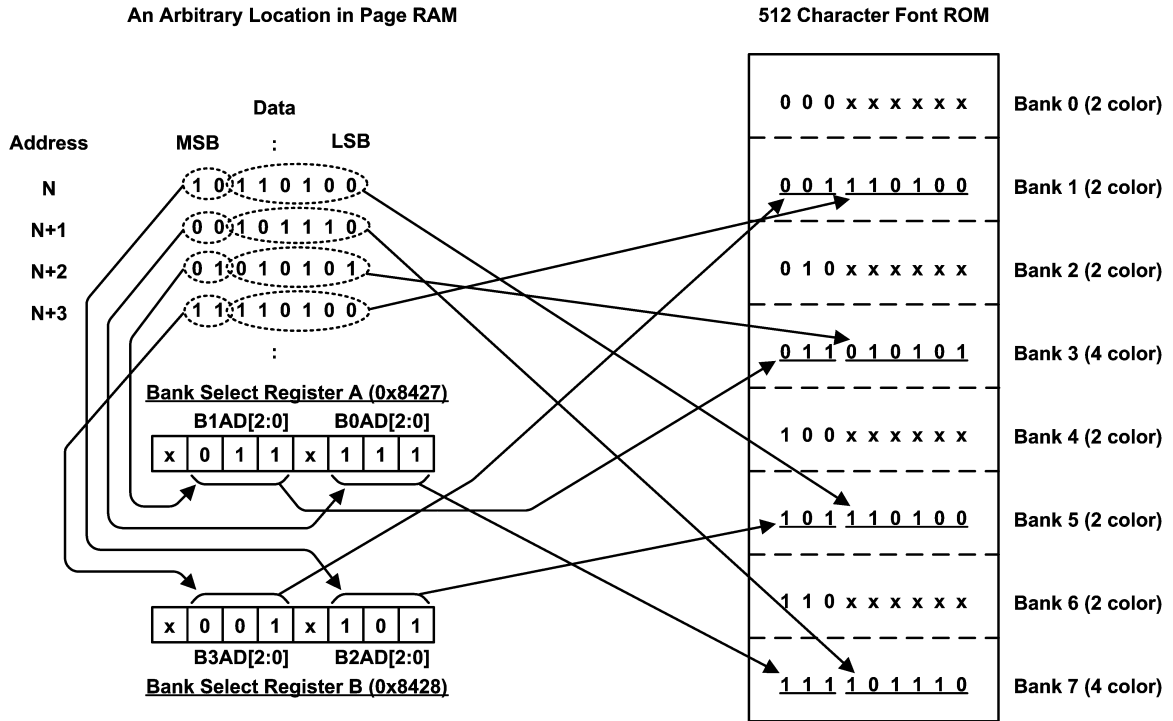

20048428

FIGURE 13. Bank Addressing

WINDOWS

Two separate windows can be opened, utilizing the data stored in the page RAM. Each window has its own horizontal and vertical start position, although the second window should be horizontally spaced at least two character spaces away from the first window, and should never overlap the first window when both windows are on. The OSD window must be placed within the active video.

OSD VIDEO DAC

The OSD DAC is controlled by the 9-bit (3x3 bits) OSD video information coming from the pixel serializer look-up table. The look-up table in the OSD palette is programmed to

select 4 color levels out of 8 linearly spaced levels per channel. The OSD DAC is shown in Figure 14, where the gain is programmable by the 2-bit OSD contrast register, in 4 stages to give the required OSD signal. The OSD DACs use the reference voltage, V_{REF}, to bias the OSD outputs.

OSD VIDEO TIMING

The OSD analog signal then goes to the switch, shown in Figure 14 and Figure 1 where the timing control switches from input video to OSD and back again as determined by the control registers. This is also where horizontal and vertical blanking are also inserted at their appropriate intervals.

OSD Generator Operation (Continued)

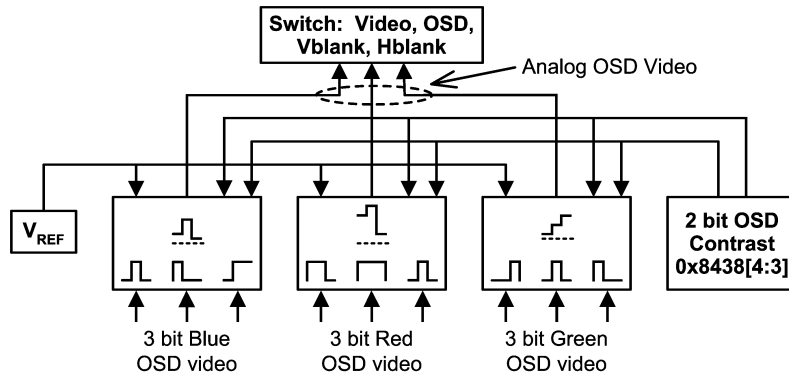

20048429

FIGURE 14. Block Diagram of OSD DACs

CHARACTER CELL

Each character is defined as a 12 column by 18 row matrix of picture elements, or "pixels". The character font is shown in Figure 29 through Figure 36. There are two types of characters defined in the character ROM:

1. Two-color: There are a total of 384 two-color characters in 6 banks (banks 0, 1, 2, 4, 5 and 6). Each pixel of these characters is defined by a single bit value. If the bit value is 0, then the color is defined as "Color 0" or the "background" color. If the bit value is 1, then the color is defined as "Color 1", or the "foreground" color. An example of a character is shown in Figure 15. The grid lines are shown for clarity to delineate individual pixels and are not part of the actual displayed character.
2. Four-color: There are a total of 128 four-color characters, in two banks of 64 (banks 3 and 7). Each pixel of the four-color character is defined by two bits of information, and thus can define four different colors, Color 0, Color 1, Color 2 and Color 3. Color 0 is defined as the "background" color. All other colors are considered "fore-

ground" colors, although for most purposes, any of the four colors may be used in any way. Because each four-color character has two bits, the LM1247 internally has a matrix of two planes of ROM as shown in Figure 16. In that figure, dark pixels indicate a logic "1" and light pixels which indicate a logic "0". The left side shows plane 0 which is the least significant bit and the middle figure shows plane 1 which is the most significant bit. The right side composite character formed when each pixel is represented by its two bits formed from the two planes. The color palette used in this example is "00" for white, "01" for black, "10" for blue and "11" for red.

3. By appropriately selecting the color attributes, it is possible to have two 2-color characters in one four color ROM location. If the required number of four color characters is less than 128, the remaining characters can be used to increase the number of two color characters from 384 to $384 + 2^N$, where N is the number of unused four color characters. This is explained in the next section.

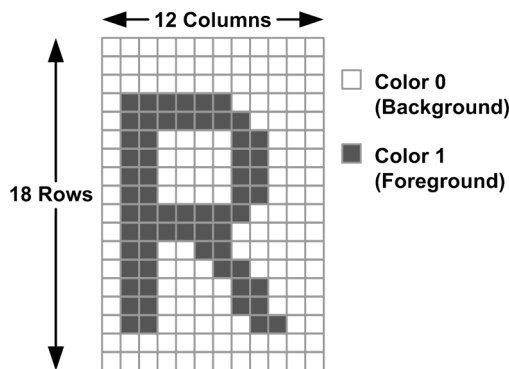

20048430

FIGURE 15. Two-Color Character

OSD Generator Operation (Continued)

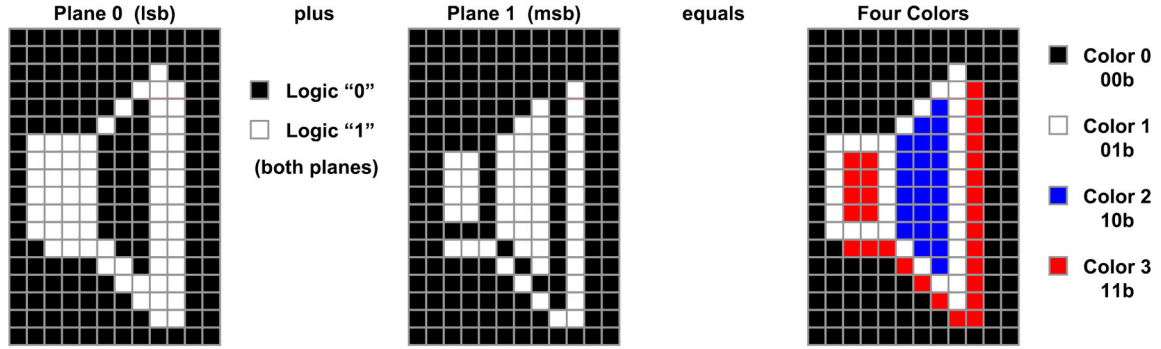

20048431

FIGURE 16. Four-Color Character

FOUR COLOR FONT AS TWO 2-COLOR

Using a 4 color character as two 2 color characters is achieved by careful assignment of the four colors. When two 2 color characters are combined, there will be four pixel colors:

- Color 0: Those that are background pixels for both characters,
- Color 1: Those that are foreground pixels in character one and background pixels in character two,
- Color 2: Those that are foreground pixels in character two and background pixels in character one,
- Color 3: Those that are foreground pixels for both characters.

In order to identify which pixels are which, both characters should be drawn in one character cell using the same background color, and different background colors. In *Figure 17*, both "A" and a "B" are drawn separately, then superimposed,

with the final 4 color character on the right. Comparing it to the list of colors, it is seen that white is color 0, black is color 1, blue is color 2 and red is color 3. (These particular four colors were chosen for clarity).

Figure 18 shows the composite four color character in the center and the palette choices on the left and the right which result in the display of the two original characters.

To display character 1, which has a foreground color 1, character 2 must be hidden by setting its foreground color (color 2) to equal the background (color 0) to equal the background (color 1). In this case, color 0 and color 2 are black and color 1 and color 3 are white.

To display character 2, set color 1 = color 0 (to hide character 1) and color 3 = color 2. Other than this, there is no restriction on the choice of the actual colors used.

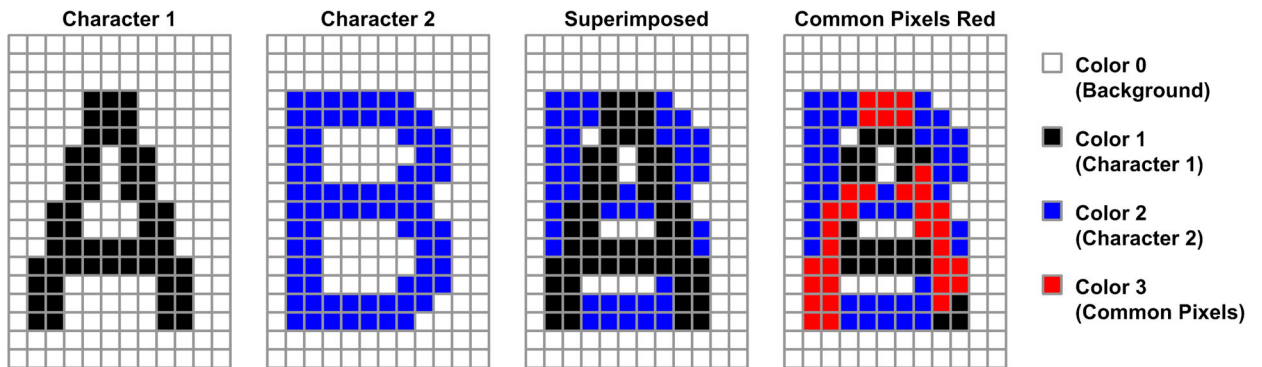

20048432

FIGURE 17. Four Color Character as a 2 x 2 Color

OSD Generator Operation (Continued)

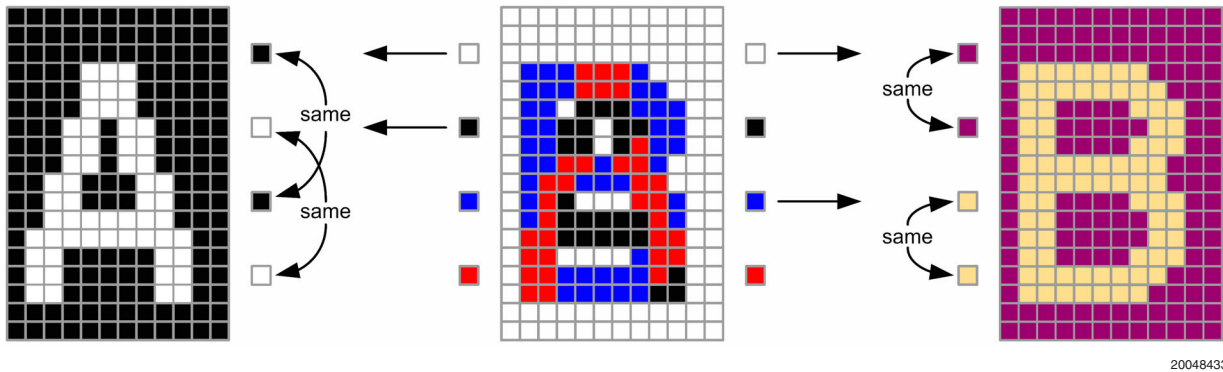

FIGURE 18. Displaying Each Character Individually

ATTRIBUTE TABLES

Each character has an attribute value assigned to it in the page RAM. The attribute value is 4 bits wide, making each character entry in the page RAM 12 bits wide in total. The attribute value acts as an address which points to one of 16 entries in either the two-color attribute table RAM or the four-color attribute table RAM. The attribute word in the table contains the coding information which defines which color is represented by color 0 and color 1 in the two color attribute table and color 0, color 1, color 2, color 3 in the four-color attribute table. Each color is defined by a 9-bit value, with 3 bits assigned to each channel of RGB. A dynamic look-up table defines each of the 16 different color “palettes”. As the look-up table can be dynamically coded by the microcontroller over the I²C compatible interface, each color can be assigned to any one of 2⁹ (i.e. 512) choices. This allows a maximum of 64 different colors to be used within one page using the 4-color characters, with up to 4 different colors within any one character and 32 different colors using the 2-color characters, with 2 different colors within any one character.

TRANSPARENT DISABLE

In addition to the 9 lines of video data, a tenth data line is generated by the transparent disable bit. When this line is activated, the black color code will be translated as “transparent” or invisible. This allows the video information from the PC system to be visible on the screen when this is present. Note that this feature is enabled on any black color in of the first 8 attribute table entries.

ENHANCED FEATURES

In addition to the wide selection of colors for each character, additional character features can be selected on a character by character basis. There are 3 Enhanced Feature Registers, EF0, EF1 and EF2.

1. Button Boxes—The OSD generator examines the character string being displayed and if the “button box” at-

tributes have been set in the Enhanced feature byte, then a box creator selectively substitutes the character pixels in either or both the top and left most pixel line or column with a button box pixel. The shade of the button box pixel depends upon whether a “depressed” or “raised” box is required, and can be programmed through the I²C compatible interface. The raised pixel color (“highlight”) is defined by the value in the color palette register, EF1 (0x8405 - 0x8406), which is normally set to white. The depressed pixel (“lowlight”) color by the value in the color palette register, EF2 (0x8407 - 0x8408), which is normally set to gray. See *Figure 19* for detail and *Figure 20* for the on-screen effect.

2. Heavy Button Boxes—When heavy button boxes are selected, the color palette value stored in register EF3 (0x8409 - 0x840A) is used for the depressed (“lowlight”) pixel color instead of the value in register EF2.
3. Shadowing—Shadowing can be added to two-color characters by choosing the appropriate attribute value for the character. When a character is shadowed, a shadow pixel is added to the lower right edges of the color 1 image, as shown in *Figure 21*. The color of the shadow is determined by the value in the color palette register EF3, which is normally set to black.
4. Bordering—A border can be added to the two-color characters. When a character is bordered, a border pixel is added at every horizontal, vertical or diagonal transition between color 0 and color 1. See *Figure 22*. The color of the border is determined by the value in the color palette register EF3 (normally black).
5. Blinking—If blinking is enabled as an attribute, all colors within the character except the button box pixels which have been overwritten will alternately switch to color 0 and then back to the correct color at a rate determined by the microcontroller through the I²C compatible interface.

OSD Generator Operation (Continued)

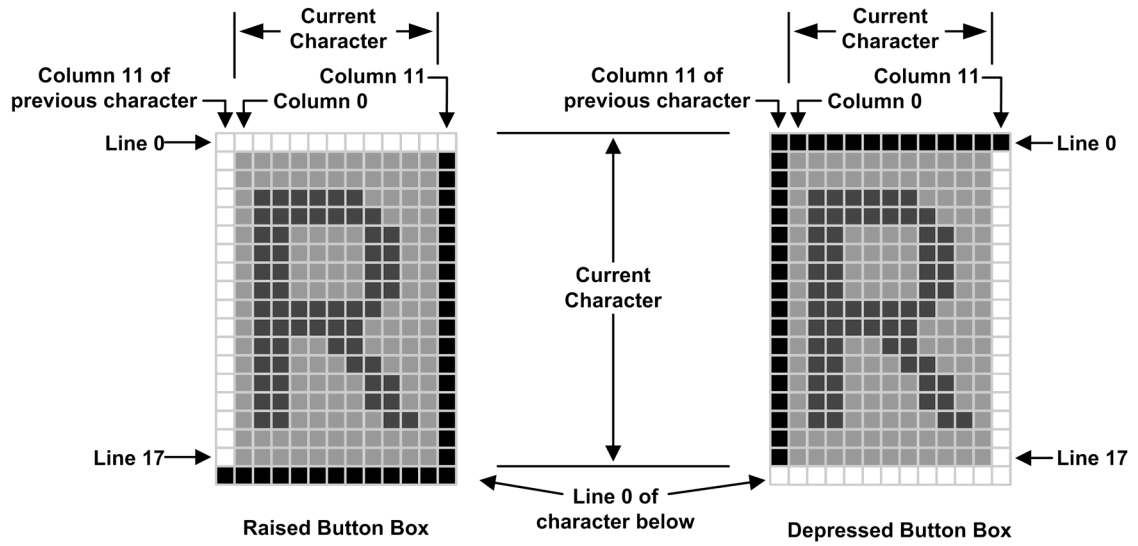

20048434

FIGURE 19. Button Box Detail

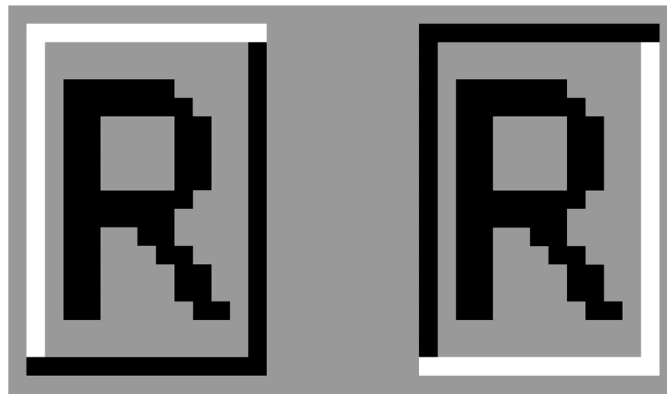

20048435

FIGURE 20. On-Screen Effect of Button Boxes

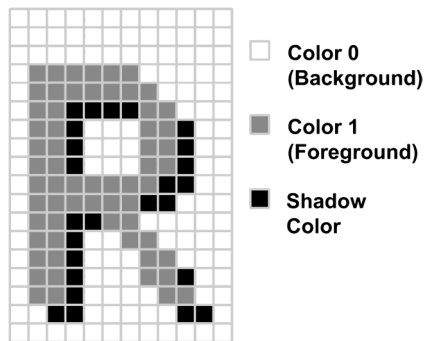

20048436

FIGURE 21. Shadowing

OSD Generator Operation (Continued)

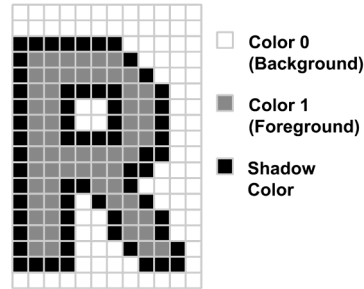

20048437

FIGURE 22. Bordering

Microcontroller Interface

The microcontroller interfaces to the LM1247 preamp using the I²C compatible interface. The protocol of the interface begins with a Start Pulse followed by a byte comprised of a seven bit Slave Device Address and a Read/Write bit. Since the first byte is composed of both the address and the read/write bit, the address of the LM1247 for writing is 0xBA (10111010b) and the address for reading is 0xBB (10111011b). The development software provided by National Semiconductor will automatically take care of the difference between the read and write addresses if the target address under the communications tab is set to 0xBA. Figure 19 and Figure 20 show a write and read sequence on the I²C compatible interface.

WRITE SEQUENCE

The write sequence begins with a start condition which consists of the master pulling SDA low while SCL is held high. The Slave Device Write Address, 0xBA, is sent next. Each byte that is sent is followed by an acknowledge. When SCL is high the master will release the SDA line. The slave must pull SDA low to acknowledge. The register to be written to is next sent in two bytes, the least significant byte being sent first. The master can then send the data, which consists of one or more bytes. Each data byte is followed by an

acknowledge bit. If more than one data byte is sent the data will increment to the next address location. See Figure 23.

READ SEQUENCE

Read sequences are comprised of two I²C compatible transfer sequences: The first is a write sequence that only transfers the two byte address to be accessed. The second is a read sequence that starts at the address transferred in the previous address only write access and increments to the next address upon every data byte read. This is shown in Figure 24. The write sequence consists of the Start Pulse, the Slave Device Address (0xBA), and the Acknowledge bit; the next byte is the least significant byte of the address to be accessed, followed by its Acknowledge bit. This is then followed by a byte containing the most significant address byte, followed by its Acknowledge bit. Then a Stop bit indicates the end of the address only write access. Next the read data access will be performed beginning with the Start Pulse, the Slave Device Read Address (0xBB), and the Acknowledge bit. The next 8 bits will be the read data driven out by the LM1247 preamp associated with the address indicated by the two address bytes. Subsequent read data bytes will correspond to the next increment address locations. Data should only be read from the LM1247 when both OSD windows are disabled.

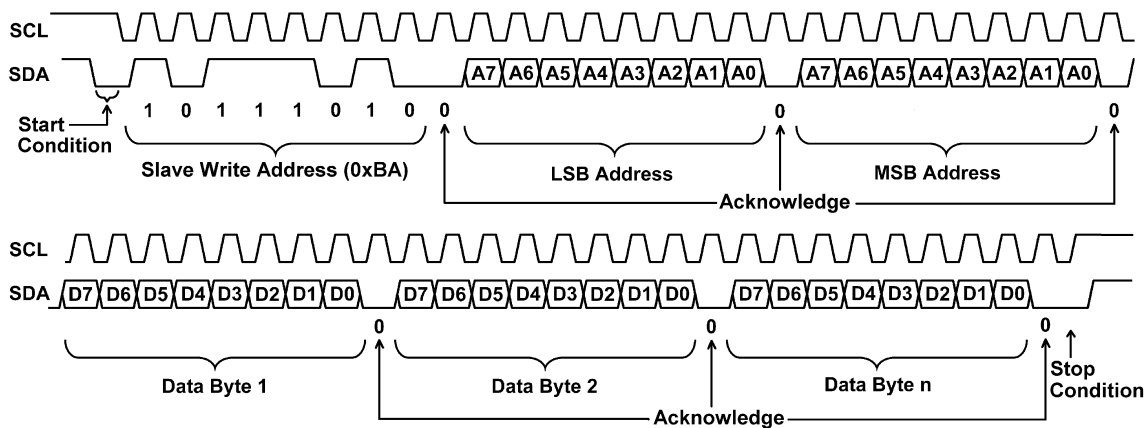

20048438

FIGURE 23. I²C Compatible Write Sequence

Microcontroller Interface (Continued)

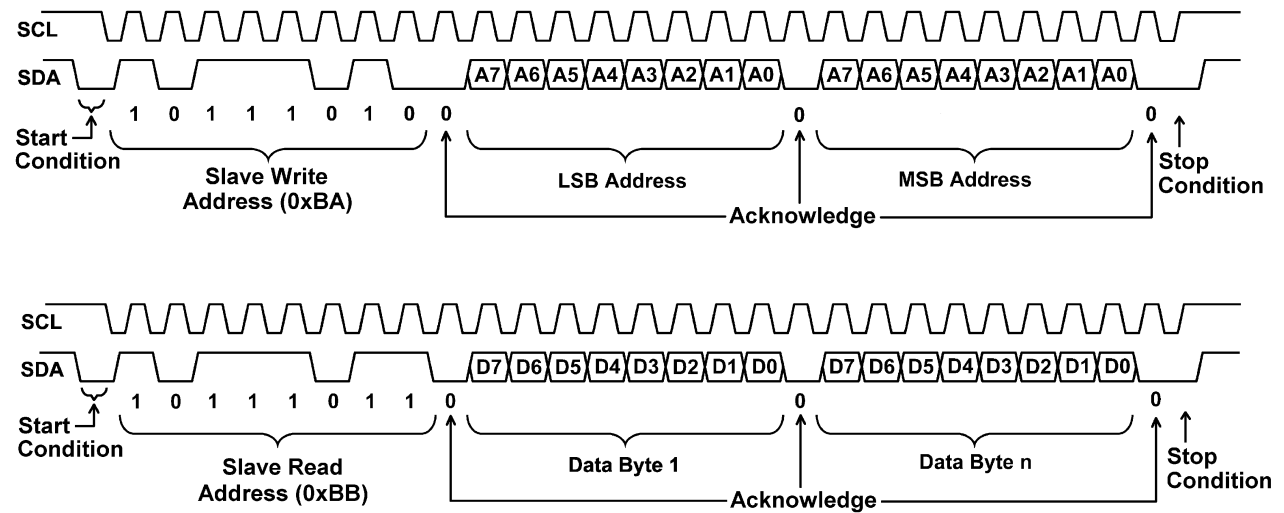

20048439

FIGURE 24. I²C Compatible Read Sequence

LM1247 Address Map

CHARACTER ROM

The 512 font characters from 0x0000 to 0x7FFF can be read from ROM by addressing the individual pixel rows of the desired character. Since the characters have 12 columns, it takes two bytes to read a given row of pixels within one character. Since the characters have 18 rows, a total of 36 bytes are needed to read the entire character. The 16 bit address for reading a row of pixels is formed as follow:

$$\text{Address} = (N * 0x1000) + (I * 0x40) + (R * 0x02) + H$$

where: N = bank number ($0x0 \leq N \leq 0x7$)

I = Character Index within its respective bank ($0x00 \leq I \leq 0x3F$)

R = row of pixels within the character ($0x00 \leq R \leq 0x11$)

H = 0 for low byte, 1 for high byte

Note that bit 0 of the Character Font Access Register, 0x8402, needs to be set to 0 to read the 2-color fonts. In order to read the four-color fonts, two complete reads are needed. Set bit 0 of the Character Font Access Register, 0x8402, to a 0 to read the least significant plane and to a 1 to read the most significant plane. See *Table 4*.

TABLE 4. Character ROM Addressing

Address Range	R/W	Description	0x8402[0]	N
0x0000–0x2FFF	R	These are the first 3 banks of two-color, read-only ROM character fonts. There are 192 total characters in this range.	0	0x0 0x1 0x2
0x3000–0x3FFF	R	This is bank 3 of four-color, read-only ROM character fonts. There are 64 total characters in this range.	0/1	0x3
0x4000–0x6FFF	R	These are banks 4, 5 and 6 of two-color read-only ROM character fonts. There are 192 characters in this range.	0	0x4 0x5 0x6
0x7000–0x7FFF	R	This is bank 7 of four-color, read-only ROM character fonts. There are 64 total characters in this range.	0/1	0x7

When read back, the low byte will contain the first eight pixels of the row with data bit 0 corresponding to the left most bit in the pixel row. The high byte will contain the remaining four pixels in the least significant nibble. The remaining 4 bits, shown as "X", are "don't care" bits, and should be discarded. Bit 3 of the high byte corresponds to the right most pixel in the pixel row. This is shown in *Table 5*.

LM1247 Address Map (Continued)

TABLE 5. Character ROM Read Data

Register	Address	D7	D6	D5	D4	D3	D2	D1	D0
Fonts - 2 Color	0x0000–0x2FFE	PIXEL[7:0]							
	+1	X	X	X	X	PIXEL[11:8]			
Fonts - 4 Color	0x3000–0x3FFE	PIXEL[7:0]							
	+1	X	X	X	X	PIXEL[11:8]			
Fonts - 2 Color	0x4000–0x6FFE	PIXEL[7:0]							
	+1	X	X	X	X	PIXEL[11:8]			
Fonts - 4 Color	0x7000–0x7FFE	PIXEL[7:0]							
	+1	X	X	X	X	PIXEL[11:8]			

DISPLAY PAGE RAM

This address range (0x8000–0x81FF) contains the 512 characters which comprise the displayable OSD screens. There must be at least one End-of-Screen code (0x00) in this range to prevent unpredictable behaviour. **NOTE:** To avoid any unpredictable behaviour, this range should be cleared by writing a 0 to bit 3 of the FRMCTRL1 Register, 0x8400, immediately after power up. There may also be one or more pairs of End-of-Line and Skip Line codes. The codes and characters are written as 8 bit bytes but are stored with their attributes in groups of 12 bits. When writing, one byte describes a displayed character (CC), Attribute Code (AC), End-of-Screen (EOS), End-of-Line (EOL) or Skip Line (SL) code. The type of code is determined by the write sequence, which must conform to the allowable sequences shown in *Table 6*. To simplify the table, CC represents one or more character codes in sequence. A single write operation is enclosed in brackets [], and the both bytes of the Page Ram Address are shown as one symbol, ADDR.

TABLE 6. Page RAM Write Sequences

OSD Image Consists of	Write Sequence(s)
One Line of Characters Only.	[ADDR-AC-SL-CC-EOS]
One Line of Characters with Attribute Change.	[ADDR-AC-SL-CC] [ADDR-AC-CC-EOS]
Two Lines of Characters with one Attribute.	[ADDR-AC-SL-CC-EOL-SL-CC-EOS]
Two Lines of Characters Separated with Skip Line.	[ADDR-AC-SL-CC-EOL-AC-SL-EOL-AC-SL-CC-EOS]
Two Lines of Characters, each with its own Attribute.	[ADDR-AC-SL-CC-EOL] [ADDR-AC-SL-CC-EOS]
Changing a Character String in a Displayed Screen.	[ADDR-AC-CC]
Changing Only an Attribute in a Displayed Screen.	[ADDR-CC] (CC is the currently displayed character)

When reading characters from RAM, bit 1 of the Character Font Access Register (0x8402) determines whether the character code or its attribute code is returned. *Table 7* gives the character code format read when bit 1 of the Character Font Access Register is a 0. *Table 8* gives the attribute format read when this bit is set to a 1.

TABLE 7. Page RAM Character Read Data

Address Range	D7	D6	D5	D4	D3	D2	D1	D0
0x8000–0x81FF	CHAR_CODE[7:0]							

TABLE 8. Page RAM Attribute Read Data

Address	D7	D6	D5	D4	D3	D2	D1	D0
0x8000–0x81FF	x	x	x	x	ATTR_CODE[3:0]			

RAM DATA FORMAT

Each of the 512 locations in the page RAM is comprised of a 12-bit code consisting of an 8-bit character or control code, and a 4-bit attribute code. Each of the characters are stored in sequence in the page RAM in bits 7:0. Special codes are used between lines to show where one line ends and the next begins, and also to allow blank (or “skipped”) single scan lines to be added between character lines. *Table 9* shows the format of a character stored in RAM. Note that even though this is a 12 bit format, reading and writing characters and codes is done in 8 bytes.

LM1247 Address Map (Continued)

TABLE 9. Page RAM Format

ATTRIBUTE CODE	CHARACTER CODE	
	BANK SEL.	BANK CHARACTER
ATT[3:0]	CC[7:6]	CC[5:0]

Bits 7-6 determine which Bank Select Register is used to look up the 3 bit address of the bank where the character will be called from. Bits 5-0 determine which of the 64 characters is called from that bank. Bits 11-8 address one of the 16 attributes in the table containing the colors and enhanced features to be used for this particular character. Two separate attribute tables are used, one for 2-color characters, the other for 4-color characters. Note there are 16 available attributes for 2-color characters and a different set of 16 available attributes for 4-color characters. It is the bank number in the register called by the Bank Select bits, which determines whether the character has a 2-color or 4-color attribute.

ATTRIBUTE CODE

The attribute code to be used for subsequent characters is written just as a character code or control code, but is stored with each of the characters which are subsequently written to the Page RAM until the write operation ends. The attribute code is identified as the first byte sent in a write operation. This attribute code addresses one of 16 locations in the attribute table, and is shown in *Table 10*. This code is used for all following characters until a new attribute code is written with a new write operation.

TABLE 10. Attribute Code

ATTRIBUTE CODE				
X	X	X	X	ATT[3:0]

Bits 7-4 of this byte are reserved and should be written as zeros. Bits 3-0 are stored in bits 11:8 of the Page RAM, along with its corresponding character codes and selects one of the 16 entries in the attribute table (described later).

END-OF-LINE CODE

To signify the end of a line of characters, a special End-of-Line (EOL) code is used in place of a character code. This code, shown in *Table 11* tells the OSD generator that the character and attribute codes which follow must be placed on a new line in the displayed window. Bits 7-1 are zeros, bit 0 is a one. The attribute which is stored in Page RAM along with this code is not used.

TABLE 11. End-of-Line Code

ATTRIBUTE CODE	END-OF-LINE CODE								
ATT[3:0]	0	0	0	0	0	0	0	0	1

SKIP-LINE CODE

In order to allow finer control of the vertical spacing of character lines, each displayed line of characters may have up to 15 skipped (i.e., blank) lines between it and the line beneath it. Each skipped line is treated as a single character pixel line, so multiple scan lines may actually be displayed in order to maintain accurate size relative to the character cell. An internal algorithm maintains vertical height proportionality (see the section on Constant Character Height Mechanism). To specify the number of skipped lines, the first character in each new line of characters is interpreted differently than the others in the line. Its data are interpreted as shown in *Table 12*, with the attribute bits setting the color of the skipped lines.

TABLE 12. Skipped-Line Code

ATTRIBUTE CODE	NUMBER OF SKIPPED LINES				
ATT[3:0]	X	X	X	X	SL[3:0]

Bits 7-4 are reserved and should be set to zero. Bits 3-0 determine how many blank pixel lines will be inserted between the present line of display characters and the next. A range of 0-15 may be selected. Bits 11-8 determine which attribute the pixels in the skipped lines will have, which is always called from the two-color attribute table. The pixels will have the background color (Color 0) of the selected attribute table entry.

Note that the pixels in the first line immediately below the character may be overwritten by the pixel override system that creates the button box. (Refer to the Button Box Formation Section for more information).

After the first line, each new line always starts with an SL code, even if the number of skipped lines to follow is zero. This means an SL code must always follow an EOL code. An EOL code may follow an SL code if several "transparent" lines are required between sections of the window. See example 3 below for a case where skipped lines of zero characters are displayed, resulting in one window being displayed in two segments.

LM1247 Address Map (Continued)

END-OF-SCREEN CODE

To signify the end of the window, a special End-of-Screen (EOS) code is used in place of a End-of-Line (EOL) code. There must be at least one EOS code in the Page RAM to avoid unpredictable behaviour. This can be accomplished by clearing the RAM by writing a 0 to bit 3 of the FRMCTRL1 Register, 0x8400, immediately after power up.

TABLE 13. End-of-Screen Code

ATTRIBUTE CODE	END-OF-SCREEN CODE							
ATT[3:0]	0	0	0	0	0	0	0	0

Bits 7-0 are all zeros. Bits 11-0 will have the previously entered AC but this is not used and so these bits are “don't cares”.

OSD CONTROL REGISTERS

These registers, shown in *Table 14*, control the size, position, enhanced features and ROM bank selection of up to two independent OSD windows. Any bits marked as “X” are reserved and should be written to with zeros and should be ignored when the register is read. Additional register detail is provided in the *Control Register Definitions Section*, later in this document.

TABLE 14. OSD Control Register Detail

Register	Address	Default	D7	D6	D5	D4	D3	D2	D1	D0
FRMCTRL1	0x8400	0x10	X	X	X	TD	CDPR	D2E	D1E	OSE
FRMCTRL2	0x8401	0x80	PIXELS_PER_LINE[2:0]			BLINK_PERIOD[4:0]				
CHARFONTACC	0x8402	0x00	X	X	X	X	X	X	ATTR	FONT4
VLANKDUR	0x8403	0x10	X	VBLANK_DURATION[6:0]						
CHARHTCTRL	0x8404	0x51	CHAR_HEIGHT[7:0]							
BBHLCTRLB0	0x8405	0xFF	B[1:0]		G[2:0]			R[2:0]		
BBHLCTRLB1	0x8406	0x01	X	X	X	X	X	X	X	B[2]
BBLLCTRLB0	0x8407	0x00	B[1:0]		G[2:0]			R[2:0]		
BBLLCTRLB1	0x8408	0x00	X	X	X	X	X	X	X	B[2]
CHSDWCTRLB0	0x8409	0x00	B[1:0]		G[2:0]			R[2:0]		
CHSDWCTRLB1	0x840A	0x00	X	X	X	X	X	X	X	B[2]
ROMSIGCTRL	0x840D	0x00	X	X	X	X	X	X	X	CRS
ROMSIGDATAB0	0x840E	0x00	CRC[7:0]							
ROMSIGDATAB1	0x840F	0x00	CRC[15:8]							
HSTR1	0x8410	0x13	HPOS[7:0]							
VSTR1	0x8411	0x14	VPOS[7:0]							
W1STR1ADRL	0x8412	0x00	ADDR[7:0]							
W1STR1ADRH	0x8413	0x00	X	X	X	X	X	X	X	ADDR[8]
COLWIDTH1B0	0x8414	0x00	COL[7:0]							
COLWIDTH1B1	0x8415	0x00	COL[15:8]							
COLWIDTH1B2	0x8416	0x00	COL[23:16]							
COLWIDTH1B3	0x8417	0x00	COL[31:24]							
HSTR2	0x8418	0x56	HPOS[7:0]							
VSTR2	0x8419	0x5B	VPOS[7:0]							
W2STR1ADRL	0x841A	0x00	ADDR[7:0]							
W2STR1ADRH	0x841B	0x01	X	X	X	X	X	X	X	ADDR[8]
COLWIDTH2B0	0x841C	0x00	COL[7:0]							
COLWIDTH2B1	0x841D	0x00	COL[15:8]							
COLWIDTH2B2	0x841E	0x00	COL[23:16]							
COLWIDTH2B3	0x841F	0x00	COL[31:24]							
Any registers in the range of 0x8420 - 0x8426 are for National Semiconductor internal use only and should not be written to under application conditions.										
BANKSEL_0-1	0x8427	0x10	X	B1AD[2:0]			X	B0AD[2:0]		
BANKSEL_2-3	0x8428	0x32	X	B3AD[2:0]			X	B2AD[2:0]		

LM1247 Address Map (Continued)

PREAMPLIFIER CONTROL

These registers, shown in *Table 15*, control the gains, DAC outputs, PLL, horizontal and vertical blanking, OSD contrast and DC offset of the video outputs. Any bits marked as "X" are reserved and should be written to with zeros and should be ignored when the register is read. Additional register detail is provided in the *Control Register Definitions Section*, later in this document.

TABLE 15. LM1247 Preamplifier Interface Registers

Register	Address	Default	D7	D6	D5	D4	D3	D2	D1	D0
BGAINCTRL	0x8430	0xE0	X	BGAIN[6:0]						
GGAINCTRL	0x8431	0xE0	X	GGAIN[6:0]						
RGAINCTRL	0x8432	0xE0	X	RGAIN[6:0]						
CONTRCTRL	0x8433	0xE0	X	CONTRAST[6:0]						
DAC1CTRL	0x8434	0x80	DAC1[7:0]							
DAC2CTRL	0x8435	0x80	DAC2[7:0]							
DAC3CTRL	0x8436	0x80	DAC3[7:0]							
DAC4CTRL	0x8437	0x80	DAC4[7:0]							
DACOSDDCOFF	0x8438	0x94	X	DCF[1:0]	OSD CONT[1:0]		DS OFFSET[1:0]			
GLOBALCTRL	0x8439	0x00	X	X	X	X	X	X	PS	BV
AUXCTRL	0x843A	0x07	X	X	X	X	X	X	ACD	HBD
PLLREQRNG	0x843E	0x16	X	X	CLMP	X	OOD	VBL	PFR[1:0]	
SRTSTCTRL	0x843F	0x00	X	A/D[0]	X	X	X	X	X	SRST[0]

TWO-COLOR ATTRIBUTE RAM

This address range (0x8440 - 0x8497) contains the attribute lookup tables used for displaying two-color characters. There are 16 groups of 4 bytes each according to the format shown in *Table 16*. The attributes are stored starting with Color 0 (background) and each color is stored red first, green second and then blue. They may be written or read using the following address format:

$$\text{Address} = 0x8440 + (N * 0x4) + B$$

where: N = Attribute number (0x0 ≤ N ≤ 0xF)

$$B = \text{Attribute byte number (0x0 ≤ B ≤ 0x3)}$$

When reading, it is OK to read only one, two, or all three bytes. When writing more than one 2-color attribute using the auto increment feature, all four bytes must be written. When writing, bytes 0 through 2 must be written in order. Bytes 0 through 2 will take effect after byte 2 is written. Since byte 3 contains all reserved bits, this byte may be written, but will have no effect. Any bits marked as "X" are reserved and should be written to with zeros and should be ignored when the register is read.

TABLE 16. LM1247 Two-Color Attribute Registers

Register	Address	D7	D6	D5	D4	D3	D2	D1	D0
ATT2C0n	0x8440 + 4n	C0B[1:0]		C0G[2:0]		C0R[2:0]			
ATT2C1n	+1	C1B[0]	C1G[2:0]		C1R[2:0]			C0B[2]	
ATT2C2n	+2	X	X	EF[3:0]			C1B[2:1]		
ATT2C3n	+3	X	X	X	X	X	X	X	X

FOUR-COLOR ATTRIBUTE RAM

This address range (0x8500 - 0x857F), contains the attribute lookup tables used for displaying four-color characters. There are 16 groups of 8 bytes each according to the format shown in *Table 17*. The attributes are stored starting with Color 0 (background) and each color is stored red first, green second and then blue. They may be written or read using the following address format:

$$\text{Address} = 0x8500 + (N * 0x8) + B$$

where: N = Attribute number (0x0 ≤ N ≤ 0xF)

$$B = \text{Attribute byte number (0x0 ≤ B ≤ 0x7)}$$

When writing, bytes 0 through 2 must be written in order and bytes 4 through 6 must be written in order. Bytes 0 through 2 will take effect after byte 2 is written. Bytes 4 through 6 will take effect after byte 6 is written. Since bytes 5 and 7 contain all reserved bits, these bytes may be written, but no effect will result. When reading, it is OK to read only one, two, or all three bytes. If writing more than one 4-color attributes using the auto increment feature, all eight bytes must be written. Any bits marked as "X" are reserved and should be written to with zeros and should be ignored when the register is read.

LM1247 Address Map (Continued)

TABLE 17. LM1247 Four-Color Attribute Registers

Register	Address	D7	D6	D5	D4	D3	D2	D1	D0
ATT4C0n	8500 + (n*8)	C0B[1:0]		C0G[2:0]		C0R[2:0]			
ATT4C1n	+1	C1B[0]	C1G[2:0]		C1R[2:0]			C0B[2]	
ATT4C2n	+2	X	X	EF[3:0]			C1B[2:1]		
ATT4C3n	+3	X	X	X	X	X	X	X	X
ATT4C4n	+4	C2B[1:0]		C2G[2:0]		C2R[2:0]			
ATT4C5n	+5	C3B[0]	C3G[2:0]		C3R[2:0]			C2B[2]	
ATT4C6n	+6	X	X	X	X	X	X	C3B[2:1]	
ATT4C7n	+7	X	X	X	X	X	X	X	X

Building Display Pages

THE OSD WINDOW

The Display Page RAM contains all of the 8-bit display character codes and their associated 4-bit attribute codes, and the special 12-bit page control codes—the End-of-Line, skip-line parameters and End-of-Screen characters. The LM1247 has a distinct advantage over many OSD Generators that it allows variable size and format windows. The window size is not dictated by a fixed geometry area of RAM. Instead, 512 locations of 12-bit words are allocated in RAM for the definition of the windows, with special control codes to define the window size and shape.

Window width can be any length supported by the number of pixels per line that is selected divided by the number of pixels in a character line. It must be remembered that OSD characters displayed during the monitor blanking time will not be displayed on the screen, so the practical limit to the number of horizontal characters on a line is reduced by the number of characters within the horizontal blanking period.

The EOS code tells the OSD generator that the character codes following belong to another displayed window at the next window location. A EOS code may follow normal characters or an SL code, but never an EOL control code, because EOL is always followed by an AC plus an SL code.

WRITING TO THE PAGE RAM

The Display Page RAM can contain up to 512 of the above listed characters and control codes. Each character, or control code will consume one of the possible 512 locations. For convenience, a single write instruction to bit 3 of the Frame Control Register (0x8400) can reset the page RAM value to all zero. This should be done at power up to avoid unpredictable behaviour.

Display Window 1 will also start at the first location (corresponding to the I²C address 0x8000). This location must always contain the Skip-Line (SL) code associated with the first row of Display Window 1. The attribute for this SL code must be written before the SL code itself, and will be stored in the lower four bits of this memory location. Subsequent locations should contain the characters to be displayed on line 1 of Display Window 1, until the EOL code or EOS code is written into the Display Page-RAM.

The skip-line parameters associated with the next line must always be written to the location immediately after the preceding line's End-of-Line character. The only exception to this rule is when a End-of-Screen character (value 0x0000) is encountered. It is important to note that an End-of-Line character should not precede an End-of-Screen character (otherwise the End-of-Screen character will be interpreted as the next line's skip-line code). Instead, the End-of-Screen code will end the line and also the window, making it unnecessary to precede it with a EOL. The I²C Format for writing a sequence of display characters is minimized by allowing sequential characters with the same attribute code to send in a string as follows:

Byte #1: I²C Slave Address

Byte #2: LSB Register Address

Byte #3: MSB Register Address

Byte #4: Attribute Table Entry to use for the following skip-line code or characters

Byte #5: First display character, SL parameter, EOL or EOS control code

Byte #6: Second display character, SL parameter, EOL or EOS control code

Byte #7: Third display character, SL parameter, EOL or EOS control code

Byte #n: Last display character in this color sequence, SL parameter, EOL or EOS control code to use the associated Attribute Table Entry.

The Attribute Table Entry (Byte #4, of the above) is automatically associated with each subsequent display character or SL code written. The following are examples of how the Display Page RAM associates to the actual On-Screen Display Window #1.

EXAMPLE 1

A 3x2 character matrix of gray characters on a black background is to be displayed on the screen, using 2-color character codes: The actual On-Screen Display of Window #1 is shown in *Figure 25*. Note the dotted white lines are not actually part of the OSD image to be displayed. They are shown here only to designate character boundaries.

Building Display Pages (Continued)

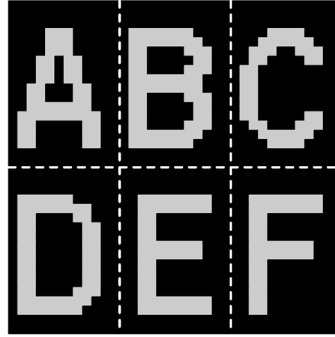

20048440

FIGURE 25. Example 1 OSD

Notes:

- The black background is Color 0 and the gray foreground is Color 1 which we will store in two-color attribute location 5 at 0x8454–0x8457.
- The Enhanced Feature portion will be set to Normal (no blinking, shadowing or button boxes, etc.)
- The character codes for “A”, “B”, etc. are from bank 4 of the sample font shown in *Figure 29* through *Figure 36*.
- For this example, bank 4 is selected by Bank Select Register 0, and therefore the two upper bits of the character codes are both 0.
- The data shown in *Table 18* is sent to the LM1247 in two transmissions, one for the attribute and one for the Page data. Also, additional data will need to be sent to position the OSD window and turn it on.
- Every line must begin with an AC and an SL code. The first location addressed by the Window 1 Start Address register must always be contain the SL for the first line of display window #1.
- Every line except the last line of a display window must end with an EOL code. The character immediately after an EOL is always the SL value for the next line, unless the window contains just one line.
- The last code in a display window must be an EOS character. The EOS must NOT follow an EOL character.
- The attributes that are associated with EOL and EOS characters are not used, so it is most efficient just to allow them to be the same value as the attribute associated with the previous display characters.
- See the Microcontroller Interface Section for I²C compatible start, stop and addressing information.

TABLE 18. Example 1 Data Transmissions

Data Sent	Description		RAM Address
	I ² C start condition		
0xBA	LM1247 Slave Write Address		
0x54	Two-color attribute location 5 address LSB		
0x84	Two-color attribute location 5 address MSB		
0x00	Attribute Byte 1 of 4	Background (Color 0): Red = 000b, Green = 000b and Blue = 000b. Foreground (Color 1): Red = 101b, Green = 101b, Blue = 101b, and Enhanced Feature = 0000b.	8454
0xDA	Attribute Byte 2 of 4		8455
0x02	Attribute Byte 3 of 4		8456
0x00	Attribute Byte 4 of 4		8457
	I ² C stop condition		
	I ² C start condition		
0xBA	LM1247 Slave Write Address		
0x00	Address LSB		
0x80	Address MSB		
0x05	Use Attribute 5 for the following characters		
0x00	Skip 0 lines code		8000
0x02	Character “A”		8001
0x03	Character “B”		8002

Building Display Pages (Continued)

TABLE 18. Example 1 Data Transmissions (Continued)

Data Sent	Description	RAM Address
0x04	Character "C"	8003
0x01	End-of-Line (EOL) code	8004
0x00	Skip 0 lines	8005
0x05	Character "D"	8006
0x06	Character "E"	8007
0x07	Character "F"	8008
0x00	End-of-Screen (EOS) code	8009
	I ² C stop condition	

EXAMPLE 2

A 3x2 character matrix of characters on a black background is to be displayed on the screen using 2-color character codes. Two gray skip lines are desired below the first line of characters, and 3 gray skip lines are desired below the second line. This is shown in *Figure 26*.

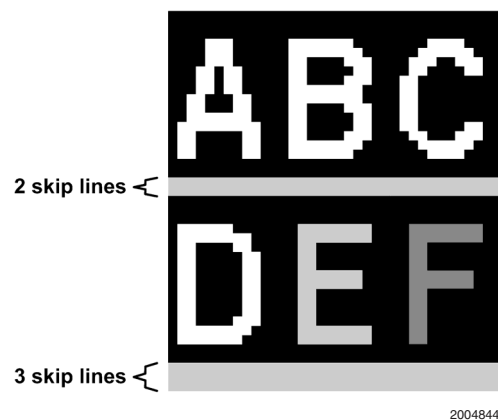

FIGURE 26. Example 2 OSD

The first line of characters will use attribute 0, the second line will use attribute 0 for the first character, attribute 1 for the second character, and attribute 2 for the third character. The skip lines will use attribute 3, which we choose to be the inverse of attribute 1.

Notes:

- The character codes for "A", "B", etc. are from bank 4 of the sample font shown in *Figure 29* through *Figure 36*.
- For this example, we assume bank 4 is selected by Bank Select Register 3, so the two upper bits of the character codes are both 1's. Therefore, the code stored in page RAM for the "A" will be 0xC2.
- Every line begins with an AC and an SL code. The first location addressed by the Window 1 Start Address register must always contain the SL for the first line of display window #1.
- If an I²C transmission finishes without an EOL code (in the middle of a line) the first byte sent in the next transmission is an AC.
- Every line except the last line of a display window ends with an EOL code. The character immediately after an EOL is always the SL value for the next line, unless the window contains just one line.
- The last character in a display window is an EOS code. The EOS must NOT follow an EOL character.
- *Table 19* shows the data sent to the LM1247 for the entire image, in 7 transmissions.

TABLE 19. Example 2 Data Transmissions

Data Sent	Description	RAM Address
	I ² C start condition	
0xBA	LM1247 Slave Write Address	
0x40	Two-color attribute location 0 address LSB	
0x84	Two-color attribute location 0 address MSB	

Building Display Pages (Continued)

TABLE 19. Example 2 Data Transmissions (Continued)

Data Sent	Description		RAM Address
0x00	Attribute Byte 1 of 4	Background (Color 0): Red = 000b, Green = 000b and Blue = 000b. Foreground (Color 1): Red = 111b, Green = 111b, Blue = 111b, and Enhanced Feature = 0000b.	0x8440
0xFE	Attribute Byte 2 of 4		0x8441
0x03	Attribute Byte 3 of 4		0x8442
0x00	Attribute Byte 4 of 4		0x8443
0x00	Attribute Byte 1 of 4	Background (Color 0): Red = 000b, Green = 000b and Blue = 000b. Foreground (Color 1): Red = 101b, Green = 101b, Blue = 101b, and Enhanced Feature = 0000b.	0x8444
0xDA	Attribute Byte 2 of 4		0x8445
0x02	Attribute Byte 3 of 4		0x8446
0x00	Attribute Byte 4 of 4		0x8447
0x00	Attribute Byte 1 of 4	Background (Color 0): Red = 000b, Green = 000b and Blue = 000b. Foreground (Color 1): Red = 011b, Green = 011b, Blue = 011b, and Enhanced Feature = 0000b.	0x8448
0xB6	Attribute Byte 2 of 4		0x8449
0x01	Attribute Byte 3 of 4		0x844A
0x00	Attribute Byte 4 of 4		0x844B
0x6D	Attribute Byte 1 of 4	Background (Color 0): Red = 101b, Green = 101b and Blue = 101b. Foreground (Color 1): Red = 000b, Green = 000b, Blue = 000b, and Enhanced Feature = 0000b.	0x844C
0x01	Attribute Byte 2 of 4		0x844D
0x00	Attribute Byte 3 of 4		0x844E
0x00	Attribute Byte 4 of 4		0x844F
	I ² C stop condition		
	I ² C start condition		
0xBA	LM1247 Slave Write Address		
0x00	Address LSB		
0x80	Address MSB		
0x03	Use Attribute 03 for the skip characters		
0x02	Skip 2 lines		0x8000
	I ² C stop condition		
	I ² C start condition		
0xBA	LM1247 Slave Write Address		
0x01	Address LSB		
0x80	Address MSB		
0x00	Use Attribute 0 for the first three characters		
0xC2	Character "A" (two most significant bits are the bank address)		0x8001
0xC3	Character "B"		0x8002
0xC4	Character "C"		0x8003
0x01	End-of-Line (EOL) code		0x8004
	I ² C stop condition		
	I ² C start condition		
0xBA	LM1247 Slave Write Address		
0x05	Address LSB		
0x80	Address MSB		
0x03	Use Attribute 3 for the skip lines		
0x03	Skip 3 lines Command		0x8005
	I ² C stop condition		
	I ² C start condition		
0xBA	LM1247 Slave Write Address		
0x06	Address LSB		

Building Display Pages (Continued)

TABLE 19. Example 2 Data Transmissions (Continued)

Data Sent	Description	RAM Address
0x80	Address MSB	
0x00	Use Attribute 0 for the "D"	
0xC5	Character "D"	0x8006
	I ² C stop condition	
	I ² C start condition	
0xBA	LM1247 Slave Write Address	
0x07	Address LSB	
0x80	Address MSB	
0x01	Use Attribute 1 for the "E"	
0xC6	Character "E"	0x8007
	I ² C stop condition	
	I ² C start condition	
0xBA	LM1247 Slave Write Address	
0x08	Address LSB	
0x80	Address MSB	
0x02	Use Attribute 2 for the "F"	
0xC7	Character "F"	0x8008
0x01	End-of-Line (EOL) Command	0x8009
0x00	End-of-Screen (EOS) Command	0x800A
	I ² C stop condition	

EXAMPLE 3

A blue message on a yellow background is to be displayed which has two lines of different lengths. Three transparent skipped lines are required between the character lines. Again, we will use 2-color characters. This is shown in *Figure 27*.

Notes:

- The character codes used are from bank 4 of the sample font shown in *Figure 29* through *Figure 36*. The bank select settings from Example 1 will be used.
- In order to center the first line with the second, two transparent blanks will begin the first line.
- The transparent skip lines and blank characters are obtained by using attribute 0 for the SL and the two blanks, and setting bit 4 of the Frame Control Register 1 to 0. (See Control Register Definitions section).
- If instead we used attributes 8 and 9 for this example, the black would not be transparent, since transparency only operates on black colors in the first 8 attributes.
- The data shown in *Table 20* is sent to the LM1247 in two I²C transmissions.

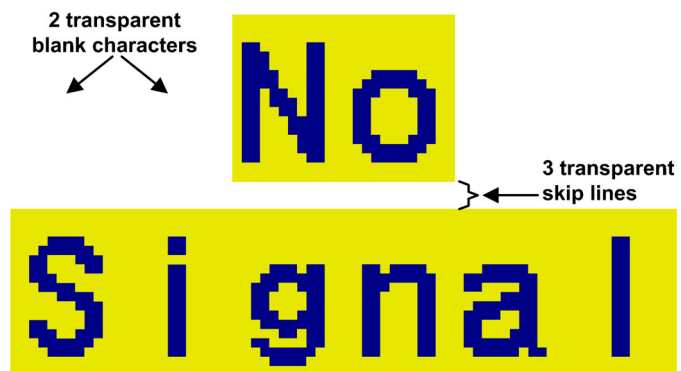

20048442

FIGURE 27. Example 3 OSD

Building Display Pages (Continued)

TABLE 20. Example 3 I²C Sequences

Data Sent	Description		RAM Address
	I ² C start condition		
0xBA	LM1247 Slave Write Address		
0x40	Two-color attribute location 0 address LSB		
0x84	Two-color attribute location 0 address MSB		
0x00	Attribute Byte 1 of 4	Background (Color 0): Red = 000b, Green = 000b and Blue = 000b. Foreground (Color 1): Red = 111b, Green = 111b, Blue = 111b, and Enhanced Feature = 0000b.	0x8440
0xFE	Attribute Byte 2 of 4		0x8441
0x03	Attribute Byte 3 of 4		0x8442
0x00	Attribute Byte 4 of 4		0x8443
0x3F	Attribute Byte 1 of 4	Background (Color 0): Red = 111b, Green = 111b and Blue = 111b. Foreground (Color 1): Red = 000b, Green = 000b, Blue = 100b, and Enhanced Feature = 0000b.	0x8444
0x00	Attribute Byte 2 of 4		0x8445
0x06	Attribute Byte 3 of 4		0x8446
0x00	Attribute Byte 4 of 4		0x8447
	I ² C stop condition		
	I ² C start condition		
0xBA	Chip Address		
0x00	Address LSB		
0x80	Address MSB		
0x00	Use Attribute 0x00 for the following characters		
0x03	Skip 2 lines Command		0x8000
0x80	Character “ ”		0x8001
0x80	Character “ ”		0x8002
	I ² C stop condition		
	I ² C start condition		
0xBA	Chip address		
0x03	Address LSB		
0x80	Address MSB		
0x01	Use Attribute 1 for the “No”		
0x0F	Character “N”		0x8003
0x30	Character “o”		0x8004
0x01	End-of-Line (EOL)		0x8005
0x00	Skip 0 lines		0x8006
0x14	Character “S”		0x8009
0x2A	Character “i”		0x800A
0x28	Character “q”		0x800B
0x2F	Character “r”		0x800C
0x22	Character “a”		0x800D
0x2D	Character “l”		0x800E
0x00	End-of-Screen (EOS) code		0x800F
	I ² C stop condition (See the Microcontroller Interface Section)		

Control Register Definitions

OSD INTERFACE REGISTERS

Frame Control Register 1:

FRMCTRL1 (0x8400)							
Reserved			trans	clear	win2	win1	OSD
X	X	X	TD	CDPR	D2E	D1E	OsE

Control Register Definitions (Continued)

Bit 0	On-Screen Display Enable. The On-Screen Display will be disabled when this bit is a zero. When this bit is a one the On-Screen Display will be enabled. This controls both Window 1 and Window 2.
Bit 1	Display Window 1 Enable. When this bit and Bit 0 of this register are both ones, Display Window 1 is enabled. If either bit is a zero, then Display Window 1 will be disabled.
Bit 2	Display Window 2 Enable. When this bit and Bit 0 of this register are both ones, Display Window 2 is enabled. If either bit is a zero, then Display Window 2 will be disabled.
Bit 3	Clear Display Page RAM. Writing a one to this bit will result in setting all of the Display Page RAM values to zero. This bit is automatically cleared after the operation is complete.
Bit 4	Transparent Disable. When this bit is a zero, a palette color of black (i.e., color palette look-up table value of 0x00) in the first 8 palette look-up table address locations (i.e., ATTO–ATT7) will be interpreted as transparent. When this bit is a one, the color will be interpreted as black.
Bits 7–5	Reserved (Should be set to zero)

Frame Control Register 2:

FRMCTRL1 (0x8401)	
Pixels per Line	Blink Period
PL[2:0]	BP[4:0]

Bits 4–0	Blinking Period. These five bits set the blinking period of the blinking feature, which is determined by multiplying the value of these bits by 8, and then multiplying the result by the vertical field rate.
Bits 7–5	Pixels per Line. These three bits determine the number of pixels per line of OSD characters. See <i>Table 21</i> which gives the maximum horizontal scan rate. Also see <i>Table 3</i> since the maximum recommended scan rate is also a function of the PLLFREQRNG register, 0x843E[1:0].

TABLE 21. OSD Pixels per Line

Bits 7–5	Description	Max Horizontal Frequency (kHz)
0x0	512 pixels per line	125
0x1	576 pixels per line	119
0x2	640 pixels per line	112
0x3	704 pixels per line	106
0x4	768 pixels per line	100
0x5	832 pixels per line	93
0x6	896 pixels per line	87
0x7	960 pixels per line	81

Character Font Access Register:

CHARFONTACC (0x8402)							
Reserved						Select	Plane
X	X	X	X	X	X	C/A	Bit

Bit 0	This is the Color Bit Plane Selector. This bit must be set to 0 to read or write a two-color attribute from the range 0x0000 to 0x2FFF. When reading or writing four-color attributes from the range 0x3000 to 0x3FFF, this bit is set to 0 for the least significant plane and to 1 for the most significant plane. It is also required to set this bit to read the individual bit planes of the four color character fonts in 0x3000 to 0x3FFF and 0x7000 to 0x7FFF.
Bit 1	This is the Character/Attribute Selector. This applies to reads from the Display Page RAM (address range 0x8000–0x81FF). When a 0, the character code is returned and when a 1, the attribute code is returned.
Bits 7–2	Reserved. These should be set to zero.

Vertical Blank Duration Register:

VBLANKDUR (0x8403)	
Res'd	Vertical Blanking Duration
X	VB[6:0]

Control Register Definitions (Continued)

Bits 6–0	This register determines the duration of the vertical blanking signal in scan lines. When vertical blanking is enabled, it is recommended that this register be set to a number greater than 0x0A.
Bit 7	Reserved. This bit should be set to zero.

Character Height Register:

CHARHTCTRL (0x8404)							
CH[7:0]							

Bits 7–0	This register determines the OSD character height as described in the section Constant Character Height Mechanism. The values of this register is equal to the approximate number of OSD height compensated lines required on the screen, divided by 4. This value is not exact due to the approximation used in scaling the character. Example: If approximately 384 OSD lines are required on the screen (regardless of the number of scan lines) then the Character Height Control Register is programmed with 81 (0x51).
----------	---

Enhanced Feature Register 1:

Button Box Highlight Color

BBHLCTRLB1 (0x8406)							BBHLCTRLB0 (0x8405)		
Reserved							Highlight - Green	Highlight - Red	Highlight - Blue
X	X	X	X	X	X	X	G[2:0]	R[2:0]	B[2:0]

Bits 8–0	These determine the button box highlight color.
Bits 15–9	Reserved. These bits should be set to zero.

Enhanced Feature Register 2:

Button Box Lowlight Color

BBLCTRLB1 (0x8408)							BBLCTRLB0 (0x8407)		
Reserved							Lowlight - Green	Lowlight - Red	Lowlight - Blue
X	X	X	X	X	X	X	G[2:0]	R[2:0]	B[2:0]

Bits 8–0	These determine the button box lowlight color.
Bits 15–9	Reserved. These bits should be set to zero.

Enhanced Feature Register 3:

Heavy Button Box Lowlight/Shading/Shadow

CHSDWCTRLB1 (0x840A)							CHSDWCTRLB0 (0x8409)		
Reserved							Shadow - Green	Shadow - Red	Shadow - Blue
X	X	X	X	X	X	X	G[2:0]	R[2:0]	B[2:0]

Bits 8–0	These registers determine the heavy button box lowlight, shading or shadow color.
Bits 15–9	Reserved. These bits should be set to zero.

ROM Signature Control Register:

ROMSIGCTRL (0x840D)							
Reserved							check
X	X	X	X	X	X	X	CRS

Bit 0	This controls the calculation of the ROM signature. Setting this bit causes the ROM to be read sequentially and a 16-bit checksum calculated over the 256 characters. The sum, modulo 65535, is stored in the ROM Signature Data Register, and this bit is then automatically cleared.
Bits 7–1	Reserved. These should be set to zero.

ROM Signature Data:

ROMSIGDATAB1 (0x840F)				ROMSIGDATAB0 (0x840E)			
16 Bit Checksum							
CRC[15:0]							

Bits 15–0	This is the checksum of the 256 ROM characters truncated to 16 bits (modulo 65535). All devices with the same masked ROM will have the same checksum.
-----------	---

Control Register Definitions (Continued)

Display Window 1 Horizontal Start Position:

HSTR1 (0x8410)
Window 1 Horizontal Start Position
1H[7:0]

Bits 7–0	There are two possible OSD windows which can be displayed simultaneously or individually. This register determines the horizontal start position of Window 1 in OSD pixels (not video signal pixels). The actual position, to the right of the horizontal flyback pulse, is determined by multiplying this register value by 4 and adding 30. Due to pipeline delays, the first usable start location is approximately 42 OSD pixels following the horizontal flyback time. For this reason, we recommend this register be programmed with a number larger than 2, otherwise improper operation may result.
----------	---

Display Window 1 Vertical Start Position:

VSTR1 (0x8411)
Window 1 Vertical Start Position
1V[7:0]

Bits 7–0	This register determines the Vertical start position of the Window 1 in constant-height character lines (not video scan lines). The actual position is determined by multiplying this register value by 2. (Note: each character line is treated as a single auto-height character pixel line, so multiple scan lines may actually be displayed in order to maintain accurate position relative to the OSD character cell size. See the Constant Character Height Mechanism section.) This register should be set so the entire OSD window is within the active video.
----------	--

Display Window 1 Start Address:

W1STRADRH (0x8413)							W1STRADRL (0x8412)				
Reserved							Window 1 Start Address				
X	X	X	X	X	X	X	1AD[8:0]				

Bits 8–0	This register determines the starting address of Display Window 1 in the Display Page RAM. The power-on default of 0x00 starts Window 1 at the beginning of the Page Ram (0x8000). This register is new for the LM1247 and allows Window 1 to start anywhere in the Page RAM rather than just at 0x8000. Note that the address this points to in Page RAM must always contain the SL code for the first line of Window 1.
Bits 15–9	These bits are reserved and should be set to zero.

Display Window 1 Column Width:

COLWIDTH1B3 (0x8417)							COLWIDTH1B2 (0x8416)				
Window 1 Column Width - High Bytes											
COL[31:16]											
COLWIDTH1B1 (0x8415)							COLWIDTH1B0 (0x8414)				
Window 1 Column Width - Low Bytes											
COL[15:0]											

Bits 31–0	These are the Display Window 1 Column Width 2x Enable Bits. These thirty-two bits correspond to columns 31–0 of Display Window 1, respectively. A value of zero indicates the column will have normal width (12 pixels). A “1” indicates the column will be twice as wide as normal (24 pixels). For the double wide case, each Character Font pixel location will be displayed twice, in two consecutive horizontal pixel locations. The user should note that if more than 32 display characters are programmed to reside on a line, then all display characters after the first thirty-two will have normal width (12 pixels).
-----------	---

Control Register Definitions (Continued)

Display Window 2 Horizontal Start Position:

HSTRT2 (0x8418)
Window 2 Horizontal Start Position
2H[7:0]

Bits 7–0	This register determines the horizontal start position of Window 2 in OSD pixels (not video signal pixels). The actual position, to the right of the horizontal flyback pulse, is determined by multiplying this register value by 4 and adding 30. Due to pipeline delays, the first usable start location is approximately 42 OSD pixels following the horizontal flyback time. For this reason, we recommend this register be programmed with a number larger than 2, otherwise improper operation may result.
----------	---

Display Window 2 Vertical Start Position:

VSTRT2 (0x8419)
Window 2 Vertical Start Position
2V[7:0]

Bits 7–0	This register determines the Vertical start position of Window 2 in constant-height character lines (not video scan lines). The actual position is determined by multiplying this register value by 2. (Note: each character line is treated as a single auto-height character pixel line, so multiple scan lines may actually be displayed in order to maintain accurate position relative to the OSD character cell size. (See the Constant Character Height Mechanism section.) This register should be set so the entire OSD window is within the active video.
----------	---

Display Window 2 Start Address:

W2STRTADRH (0x841B)							W2STRTADRL (0x841A)				
Reserved							Window 2 Start Address				
X	X	X	X	X	X	X	2AD[8:0]				

Bits 8–0	This register determines the starting address of Display Window 2 in the Display Page RAM. The power-on default of 0x100 starts Window 2 at the midpoint of the Page RAM (0x8100). This location always contains the SL code for the first line of Window 2.
Bits 15–9	These bits are reserved and should be set to zero.

Display Window 2 Column Width:

COLWIDTH2B3 (0x841F)							COLWIDTH2B2 (0x841E)				
Window 2 Column Width - High Bytes											
COL[31:16]											
COLWIDTH2B1 (0x841D)							COLWIDTH2B0 (0x841C)				
Window 2 Column Width - Low Bytes											
COL[15:0]											

Bits 31–0	These are the Display Window 2 Column Width 2x Enable Bits. These thirty-two bits correspond to columns 31–0 of Display Window 2, respectively. A value of zero indicates the column will have normal width (12 OSD pixels). A value of one indicates the column will be twice as wide as normal (24 OSD pixels). For the double wide case, each Character Font pixel location will be displayed twice, in two consecutive horizontal pixel locations. The user should note that if more than 32 display characters are programmed to reside on a row, then all display characters after the first thirty-two will have normal width (12 pixels).
-----------	---

ROM Bank Select Register A:

BANKSEL_0-1 (0x8427)			
Res'd	Bank Select 1	Res'd	Bank Select 0
X	B1AD[2:0]	X	B1AD[2:0]

Bits 2–0	This three bit field determines the ROM bank (0-7) selected when the upper two bits of the character address in Page RAM are 00 (Character Address = 00xxxxxb)
Bit 3	This bit is reserved and should be set to 0.

Control Register Definitions (Continued)

Bits 6–4	This three bit field determines the ROM bank (0-7) selected when the upper two bits of the character address in Page RAM are 01 (Character Address = 01xxxxxb)
Bit 7	This bit is reserved and should be set to 0.

ROM Bank Select Register B:

BANKSEL_2-3 (0x8428)			
Res'd	Bank Select 3	Res'd	Bank Select 2
X	B3AD[2:0]	X	B2AD[2:0]

Bits 2–0	This three bit field determines the ROM bank (0-7) selected when the upper two bits of the Page RAM addresses are 10 (Character Address = 10xxxxxb)
Bit 3	This bit is reserved and should be set to 0.
Bits 6–4	This three bit field determines the ROM bank (0-7) selected when the upper two bits of the Page RAM addresses are 11 (Character Address = 11xxxxxb)
Bit 7	This bit is reserved and should be set to 0.

The actual address for any character in ROM is formed, in logic, from the address in the Page RAM, by this sequence (also see *Figure 13*):

1. The upper 2 bits of the character address in Page RAM are used to address one of the four 3 bit fields in Bank Select Register A or Bank Select Register B. As shown in *Table 22*, depending on which of the four values is present, the corresponding 3 bit bank address is obtained from the BANKSEL_0, BANKSEL_1, BANKSEL_2, or BANKSEL_3 field shown in the last column.

TABLE 22. Address Lookup

Character Address in Page RAM	Upper Two Bits	Three Bit Bank Address Source
00xxxxxb	00b	B0AD[2:0]
01xxxxxb	01b	B1AD[2:0]
10xxxxxb	10b	B2AD[2:0]
11xxxxxb	11b	B3AD[2:0]

2. Then, the 3 bit address obtained from B0AD[2:0], B1AD[2:0], B2AD[2:0] and B3AD[2:0] are used to select four of the eight 2 or 4 color ROM banks as shown in *Table 23*. The BxAD[2:0] column gives the range of three bit addresses and the next two columns give the corresponding ROM address range and the character type.

TABLE 23. Resulting ROM Bank Address

BxAD[2:0]	Character ROM Address Range	ROM Character Type
000b	0x000 - 0x03F	2 Color
001b	0x040 - 0x07F	2 Color
010b	0x080 - 0x0BF	2 Color
011b	0x0C0 - 0x0FF	4 Color
100b	0x100 - 0x13F	2 Color
101b	0x140 - 0x17F	2 Color
110b	0x180 - 0x1BF	2 Color
111b	0x1C0 - 0x1FF	4 Color

3. In summary, the final ROM character address is formed by concatenating (combining end to end) the three bits of the corresponding Bank Address Register with the lower six bits of the original character address in RAM. Since just the two highest bits of the Page RAM address are used, only 4 banks can be addressed at one time.

Pre-Amplifier Interface Registers

Blue Channel Gain:

BGAINCTRL (0x8430)	
Res'd	Blue Gain
X	BG[6:0]

Bits 6–0	This register determines the gain of the blue video channel. This affects only the blue channel whereas the contrast register (0x8433) affects all channels.
Bit 7	Reserved and should be set to zero.

Green Channel Gain:

GGAINCTRL (0x8431)	
Res'd	Green Gain
X	GG[6:0]

Bits 6–0	This register determines the gain of the green video channel. This affects only the green channel whereas the contrast register (0x8433) affects all channels.
Bit 7	Reserved and should be set to zero.

Red Channel Gain:

RGAINCTRL (0x8432)	
Res'd	Red Gain
X	RG[6:0]

Bits 6–0	This register determines the gain of the red video channel. This affects only the red channel whereas the contrast register (0x8433) affects all channels.
Bit 7	Reserved and should be set to zero.

Contrast Control:

CONTRCTRL (0x8433)	
Res'd	Contrast
X	CG[6:0]

Bits 6–0	This register determines the contrast gain and affects all channels, blue, red and green.
Bit 7	Reserved and should be set to zero.

DAC 1 Output Level:

DAC1CTRL (0x8434)	
DAC 1 Output Level	
BC[7:0]	

Bits 7–0	This register determines the output of DAC 1. The full-scale output is determined by bit 5 of the DAC Config, OSD Contrast & DC Offset Register.
----------	--

DAC 2 Output Level:

DAC2CTRL (0x8435)	
DAC 2 Output Level	
GC[7:0]	

Bits 7–0	This register determines the output of DAC 2. The full-scale output is determined by bit 5 of the DAC Config, OSD Contrast & DC Offset Register.
----------	--

DAC 3 Output Level:

DAC3CTRL (0x8436)	
DAC 3 Output Level	
RC[7:0]	

Pre-Amplifier Interface Registers (Continued)

Bits 7–0	This register determines the output of DAC 3. The full-scale output is determined by bit 5 of the DAC Config, OSD Contrast & DC Offset Register (0x8438).
----------	---

DAC 4 Output Level:

DAC4CTRL (0x8437)
DAC 4 Output Level
BA[7:0]

Bits 7–0	This register determines the output of DAC 4. The output of this DAC can be scaled and mixed with the outputs of DACs 1–3 as determined by bit 6 of the DAC Config, OSD Contrast & DC Offset Register.
----------	--

DAC Config, OSD Contrast & DC Offset:

DACOSDDCOFF (0x8438)			
Res'd	DAC Options	OSD Contrast	DC Offset
X	DCF[1:0]	OSD[1:0]	DC[2:0]

Bits 2–0	These determine the DC offset of the three video outputs, blue, red and green.
Bits 4–3	These determine the contrast of the internally generated OSD.
Bit 5	When this bit is a 0, the full-scale outputs of DACs 1–3 are 0.5V to 4.5V. When it is a 1 the full-scale level is 0.5V to 2.5V.
Bit 6	When this bit is a 0, the DAC 4 output is independent. When it is a 1, the DAC 4 output is scaled by 50% and added to the outputs of DACs 1–3.
Bit 7	Reserved and should be set to zero.

Global Video Control:

GLOBALCTRL (0x8439)							
Reserved						Power	Blank
X	X	X	X	X	X	PS	BV

Bit 0	When this bit is a 1, the video outputs are blanked (set to black level). When it is a 0, video is not blanked.
Bit 1	When this bit is a 1, the analog sections of the preamplifier are shut down for low power consumption. When it is a 0, the analog sections are enabled.
Bits 7–2	Reserved and should be set to 0.

Auxiliary Control:

AUXCTRL (0x843A)							
Reserved						Int Clp	H Blnk
X	X	X	X	X	X	ACEn	HBEn

Bit 0	When this bit is a 1, the horizontal blanking input at pin 24 is gated to the video outputs to provide horizontal blanking. When it is a 0, the horizontal blanking at the outputs is disabled.
Bit 1	When this bit is a 1, the internal auxiliary clamp is enabled. This operates on the blue video input so that if its level falls below 0.8 VDC, then this turns the internal clamp on to raise the output level. This is not to be confused with the black level video clamp in the next register (0x843E).
Bit 2	This bit is reserved and should be set to a 1.
Bits 3–7	These bits are reserved and should be set to 0.

PLL Range:

PLLFREQRNG (0x843E)						
Reserved			Clamp	OSD	VBlank	PLL
X	X	X	CLMP	OOR	VBL	PFR[1:0]

Pre-Amplifier Interface Registers (Continued)

Bits 1–0	These determine the optimum frequency range of the Phase Locked Loop. Please see <i>Table 3</i> for recommended register values as a function of horizontal scan rate and the Pixels per Line register, 0x8401[7:5].
Bit 2	This is the Vertical Blanking register. When this bit is a 1, vertical blanking is gated to the video outputs. When set to a 0, the video outputs do not have vertical blanking.
Bit 3	This is the OSD override bit. This should be set to 0 for normal operation. When set to a 1, the video outputs are disconnected and OSD only is displayed. This is useful for the OSD display of special conditions such as “No Signal” and “Input Signal Out of Range”, to avoid seeing unsynchronized video.
Bit 4	Reserved and should be set to zero.
Bit 5	This is the Clamp Polarity bit. When set to a 0, the LM1247 expects a positive going clamp pulse. When set to a 1, the expected pulse is negative going.
Bits 7–6	Reserved and should be set to zero.

Software Reset and Test Control:

SRTSTCTRL (0x843F)							
Res'd		Reserved					Reset
X	AID	X	X	X	X	X	SRST

Bit 0	When this bit is a 1, all registers except this one are loaded with their default values. All operations are aborted, except data transfers in progress on the I ² C compatible bus. This bit clears itself when the reset is complete.
Bits 5–1	Reserved and should be set to zero.
Bit 6	This bit disables the register Auto-Increment feature of the I ² C compatible protocol. When set to a 1 Auto-Increment is disabled and when a 0, AI is enabled.
Bit 7	Reserved and should be set to zero.

Attribute Table and Enhanced Features

Each display character and SL in the Display Page RAM will have a 4-bit Attribute Table entry associated with it. The user should note that two-color display characters and four-color display characters use two different Attribute Tables, effectively providing 16 attributes for two-color display characters and 16 attributes for four-color display characters.

For two-color characters the attribute contains the code for the 9-bit foreground color (Color 1), the code for the 9-bit background color (Color 0), and the character's enhanced features (Button Box, Blinking, Heavy Box, Shadowing, Bordering, etc.).

For four-color characters the attribute contains the code for the 9-bit Color 0, the code for the 9-bit Color 1, the code for the 9-bit Color 2, the code for the 9-bit Color 3 and the character's enhanced features (Button Box, Blinking, Heavy Box, Shadowing, Bordering, etc.).

TWO COLOR ATTRIBUTE FORMAT

The address range for an attribute number, $0 \leq n \leq 15$, is provided in *Table 25*.

ATT2C3n (0x8443+n*4)								ATT2C2n (0x8442+n*4)					
Reserved								Enhanced Feature				Color 1 -	
X	X	X	X	X	X	X	X	X	X	X	X	EFB[3:0]	C1B[2:1]
ATT2C1n (0x8441+n*4)								ATT2C0n (0x8440+n*4)					
Blue	Color 1 - Green			Color 1 - Red			Color 0 - Blue			Color 0 - Green		Color 0 - Red	
C2B0	C1G[2:0]			C1R[2:0]			C0B[2:0]			C0G[2:0]		C0R[2:0]	

Bits 8–0	These nine bits determine the background color (color1) which is displayed when the corresponding OSD pixel is a 0.
Bits 17–9	These nine bits determine the foreground color (color2) which is displayed when the corresponding OSD pixel is a 1.
Bits 21–18	These are the enhanced feature (EF) bits which determine which feature is applied to the displayed character. The features and their corresponding codes are shown in <i>Table 24</i> .
Bits 31–22	Reserved and should be set to zero.

Attribute Table and Enhanced Features (Continued)

TABLE 24. Enhanced Feature Descriptions

Bits 21–18	Feature Description
0000b	Normal Display
0001b	Blinking
0010b	Shadowing
0011b	Bordering
0100b	RESERVED
0101b	RESERVED
0110b	RESERVED
0111b	RESERVED
1000b	Raised Box
1001b	Blinking and Raised Box
1010b	Depressed Box
1011b	Blinking and Depressed Box
1100b	Heavy Raised Box
1101b	Blinking and Heavy Raised Box
1110b	Heavy Depressed Box
1111b	Blinking and Heavy Depressed Box

FOUR COLOR ATTRIBUTE FORMAT

The address range for an attribute number, $0 \leq n \leq 15$, is provided in *Table 25*.

ATT4C7n (0x8507+n*4)								ATT4C6n (0x8506+n*4)							
Reserved														Color 3-	
X	X	X	X	X	X	X	X	X	X	X	X	X	X	X	C3B[2:1]
ATT4C5n (0x8505+n*4)								ATT4C4n (0x8504+n*4)							
Blue	Color 3 - Green			Color 3 - Red			Color 2 - Blue		Color 2 - Green		Color 2 - Red				
C3B0	C3G[2:0]			C3R[2:0]			C2B[2:0]		C2G[2:0]		C2R[2:0]				
ATT4C3n (0x8503+n*4)								ATT4C2n (0x8502+n*4)							
Reserved										Enhanced Features		Color 1 -			
X	X	X	X	X	X	X	X	X	X	EFB[3:0]		C1B[2:1]			
ATT4C1n (0x8501+n*4)								ATT4C0n (0x8500+n*4)							
Blue	Color 1 - Green			Color 1 - Red			Color 0 - Blue		Color 0 - Green		Color 0 - Red				
C1B0	C1G[2:0]			C1R[2:0]			C0B[2:0]		C0G[2:0]		C0R[2:0]				

Bits 8–0	These nine bits determine the color0 which is displayed when the corresponding OSD pixel code is 00b.
Bits 17–9	These nine bits determine the color1 which is displayed when the corresponding OSD pixel code is a 01b.
Bits 21–18	These are the enhanced feature (EF) bits which determine which feature is applied to the displayed character. The features and their corresponding codes are shown in <i>Table 24</i> .
Bits 31–22	Reserved and should be set to zero.
Bits 40–32	These nine bits determine the color2 which is displayed when the corresponding OSD pixel code is a 10b.
Bits 49–41	These nine bits determine the color3 which is displayed when the corresponding OSD pixel code is an 11b.
Bits 63–50	Reserved and should be set to zero.

TABLE 25. Attribute Tables and Corresponding Addresses

Attribute Number, (n)	Two-Color Attribute Table Address	Four-Color Attribute Table Address
0000b	0x8440–0x8443	0x8500–0x8507
0001b	0x8444–0x8447	0x8508–0x850F
0010b	0x8448–0x844B	0x8510–0x8517
0011b	0x844C–0x844F	0x8518–0x851F

Attribute Table and Enhanced Features (Continued)

TABLE 25. Attribute Tables and Corresponding Addresses (Continued)

Attribute Number, (n)	Two-Color Attribute Table Address	Four-Color Attribute Table Address
0100b	0x8450–0x8453	0x8520–0x8527
0101b	0x8454–0x8457	0x8528–0x852F
0110b	0x8458–0x845B	0x8530–0x8537
0111b	0x845C–0x845F	0x8538–0x853F
1000b	0x8460–0x8463	0x8540–0x8547
1001b	0x8464–0x8467	0x8548–0x854F
1010b	0x8468–0x846B	0x8550–0x8557
1011b	0x846C–0x846F	0x8558–0x855F
1100b	0x8470–0x8473	0x8560–0x8567
1101b	0x8474–0x8477	0x8568–0x856F
1110b	0x8478–0x847B	0x8570–0x8577
1111b	0x847C–0x847F	0x8578–0x857F

BUTTON BOX FORMATION

The value of the most significant Enhanced Feature Bit (EFB3) determines when to draw the left, right, bottom and top sides of a Box. EFB1 denotes whether a box is raised or depressed, and EFB2 denotes whether the box is normal or “heavy”. For normal boxes, the lowlight color is determined by the color code stored in the register EF2. For the heavy box feature, the lowlight is determined by the color code stored in register EF3. Boxes are created by a “pixel override” system that overwrites character cell pixel information with either the highlight color (EF1) or low light shadow (EF2 or EF3) of the box. Only the top pixel line of the character and the right edge of the character can be overwritten by the pixel override system.

To form a complete box, the left hand edge of a box is created by overwriting the pixels in the right most column of the preceding character to one being enclosed by the box. The bottom edge of a box is created by either—

- overwriting the pixels in the top line of the character below the character being enclosed by the box, or
- overwriting the pixels in the top line of the skipped lines below, in the case where skip lines are present below a boxed character.

Characters should be designed so that button boxes will not interfere with the character.

These are the limitations resulting from the button box formation methodology:

- No box may use the left most display character in the Display Window, or it will have no left side of the Box. To create a box around the left most displayed character, a transparent “blank” character must be used in the first character position. This character will not be visible on the screen, but allows the formation of the box.
- At least one skip line must be used beneath characters on the bottom row, if a box is required around any characters on this row in order to accommodate the bottom edge of the box.
- Skipped lines cannot be used within a box covering several rows.
- Irregular shaped boxes, (i.e., other than rectangular), may have some missing edges.

Operation of the Shadow Feature

The shadow feature is created as follows: As each 12-bit line in the character is called from ROM, the line immediately preceding it is also called and used to create a “pixel override” mask. Bits 11 through 1 of the preceding line are compared to bits 10 through 0 of the current character line. Each bit X in the current line is compared to bit X+1 in the preceding line (i.e., the pixel above and to the left of the current pixel). Note that bit 11 of the current line cannot be shadowed. A pixel override output mask is then created. When a pixel override output is 1 for a given pixel position, the color of that pixel must be substituted with the color code stored in the register EF3. Please see *Figure 28* for an example.

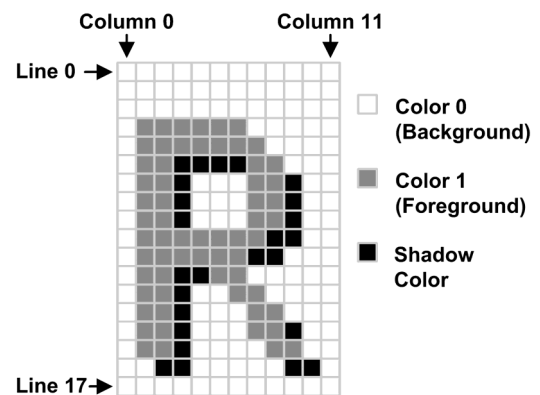

20048443

FIGURE 28. Operation of the Shadow Feature

Operation of the Bordering Feature

Borders are created in a similar manner to the shadows, using the pixel override system to overwrite pixel data with a pixel color set by EF3. However, instead of comparing just the previous line to the current line, all pixels surrounding a given pixel are examined.

The pixel override is created as follows: As each 12-bit line in the character is called from ROM, the character line immediately above and the line immediately below are also called. A “Pixel Override” output mask is then created by looking at

Attribute Table and Enhanced Features (Continued)

all pixels surrounding the pixel. When a black override output is 1 for a given pixel position, X, the color of that pixel changed to the color code stored in the register EF3.

Because the shadowing relies upon information about the pixels surrounding any given pixel, the bordering system may not operate correctly for pixels in the perimeter of the character (line 0 and 17, columns 0 and 11).

Constant Character Height Mechanism

The CRT monitor scan circuits ensure that the height of the displayed image remains constant so the physical height of a single displayed pixel row will decrease as the total number of image scan lines increases. As the OSD character matrix has a fixed number of lines, C, (where C = 18), then the character height will reduce as the number of scan lines increase, assuming a constant image height. To prevent this, the OSD generator repeats some of the lines in the OSD character in order to maintain a constant height percentage of the vertical image size.

In the LM1247, an approximation method is used to determine which lines are repeated, and how many times each line is repeated. The constant character height mechanism will not decrease the OSD character matrix to less than 18 lines.

Display Window 1 to Display Window 2 Spacing

There is no required vertical spacing between Display Window 1 and Display Window 2, but they should not overlap. There must be a two-character horizontal space between Display Window 1 and Display Window 2 for proper operation of both windows or undefined results may occur.

Evaluation Character Fonts

The character font for evaluation of the LM1247 is shown in Figure 29 through Figure 36, where each represents one of the 8 available ROM banks. Each bank is shown with increasing character address going from upper left to low right. The actual font will depend on customer customization requirements.

Note that the first two character codes of the two-color font in ROM bank 4 (0x00 and 0x01) are carried over from the LM1237 ROM where they were reserved for the End-of-Screen (EOS) and End-of-Line (EOL) codes respectively.

In the case of the LM1247, these two locations can be used for displayable characters as long as they are not needed when this bank is addressed from Bank Select Register 0. If it is addressed from Bank Select Registers 1, 2 or 3 then these two lower characters will be usable. Please see the section "END-OF-LINE AND END-OF-SCREEN CODES". Similarly, the first two characters in any bank which is addressed from Bank Select Register 0 will not be usable since those addresses will be interpreted as the EOL and EOS codes.

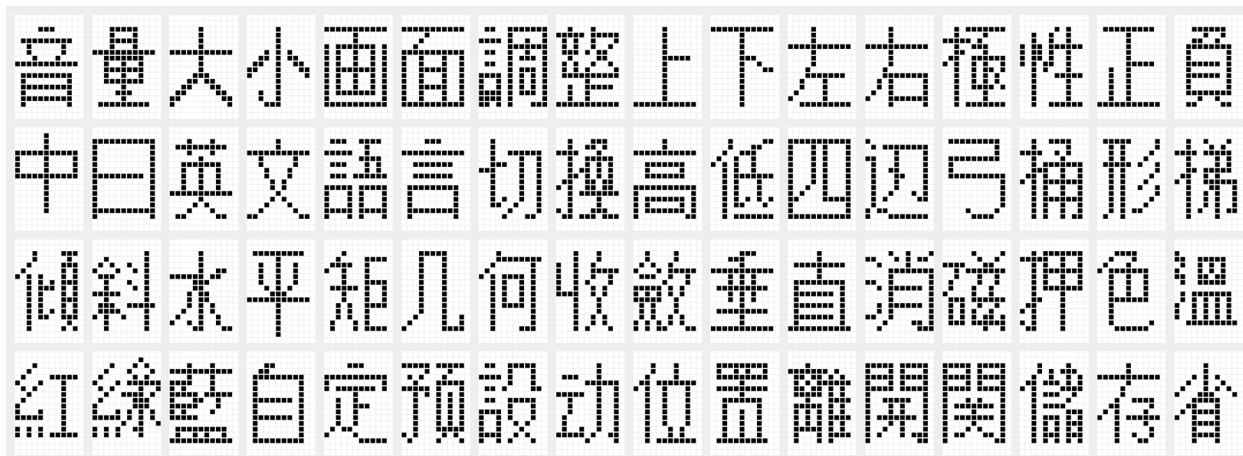

20048444

FIGURE 29. ROM Bank 0 Two Color Character Font

Attribute Table and Enhanced Features (Continued)



20048445

FIGURE 30. ROM Bank 1 Two Color Character Font

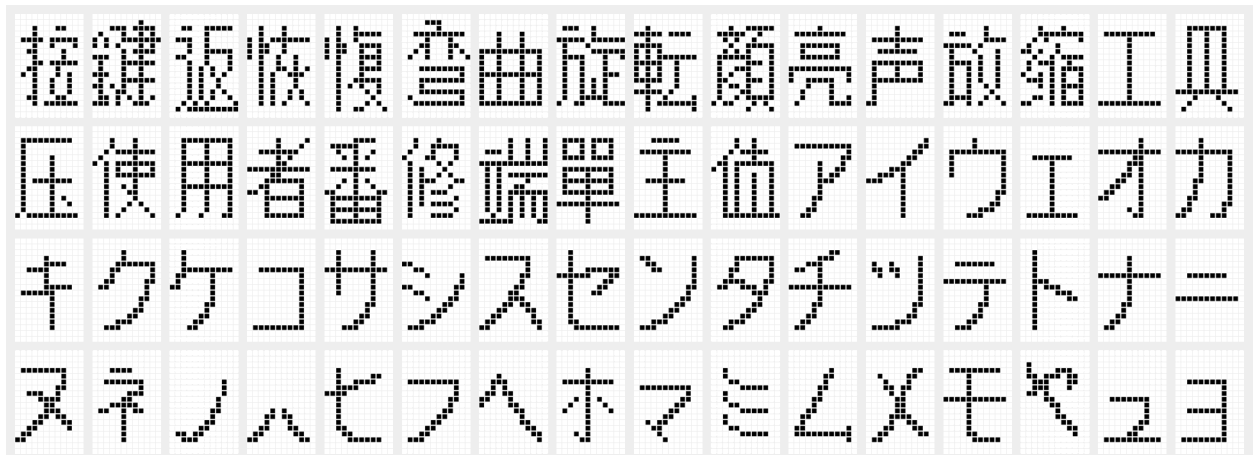

20048446

FIGURE 31. ROM Bank 2 Two Color Character Font

Attribute Table and Enhanced Features (Continued)



20048447

FIGURE 32. ROM Bank 3 Four Color Character Font



20048448

FIGURE 33. ROM Bank 4 Two Color Character Font

Attribute Table and Enhanced Features (Continued)

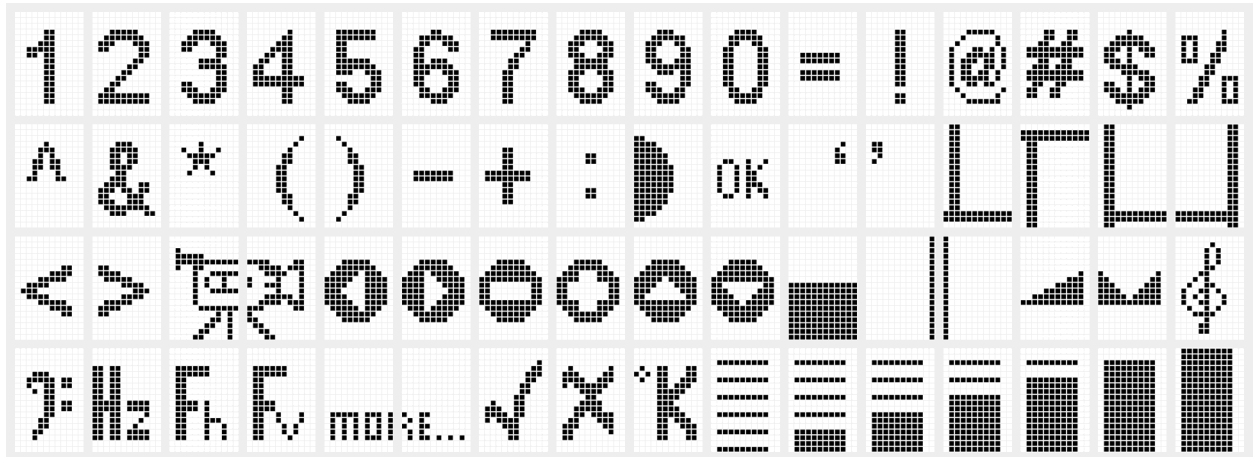

20048449

FIGURE 34. ROM Bank 5 Two Color Character Font

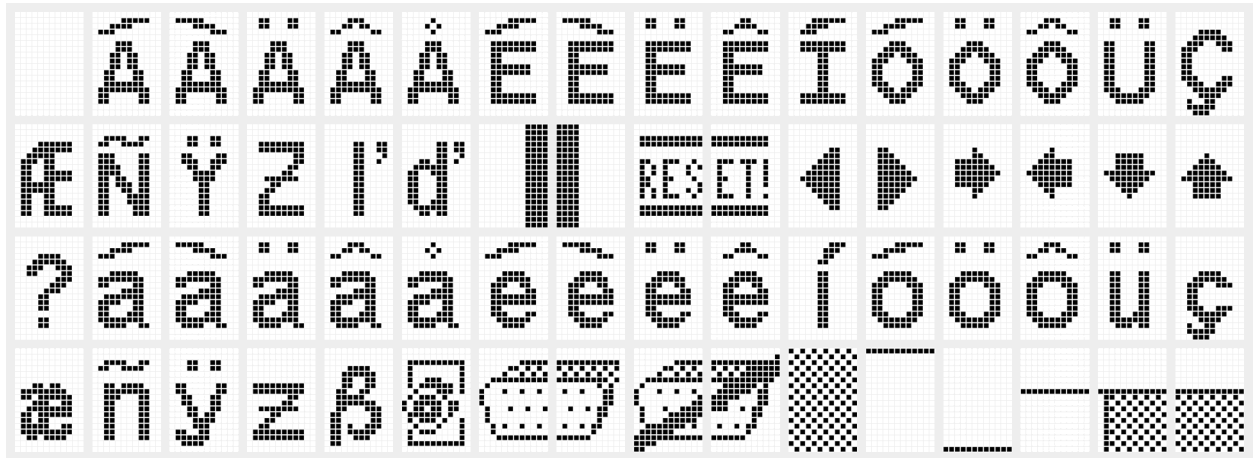

20048450

FIGURE 35. ROM Bank 6 Two Color Character Font

Attribute Table and Enhanced Features (Continued)

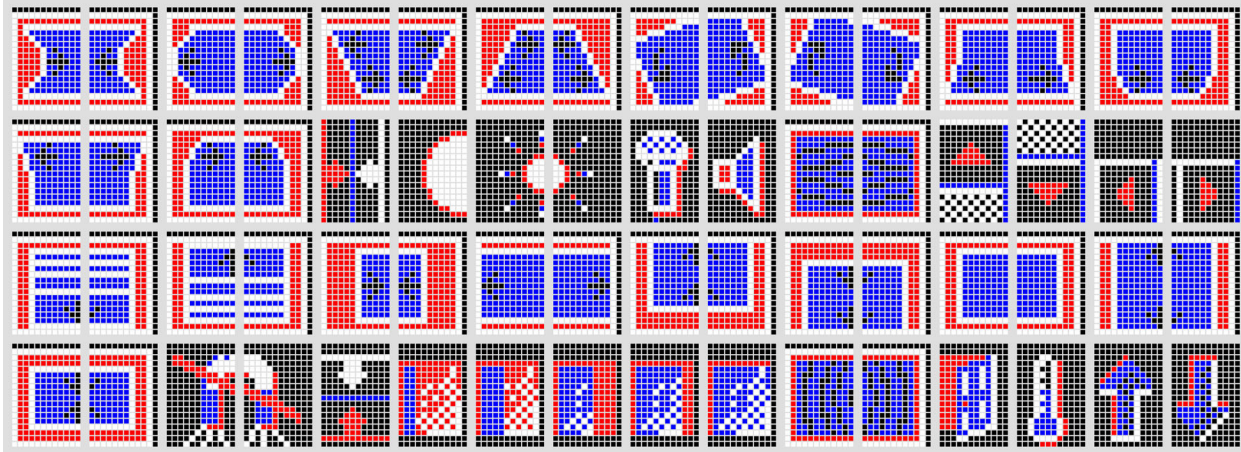

20048451

FIGURE 36. ROM Bank 7 Four Color Character Font

Physical Dimensions inches (millimeters)

unless otherwise noted

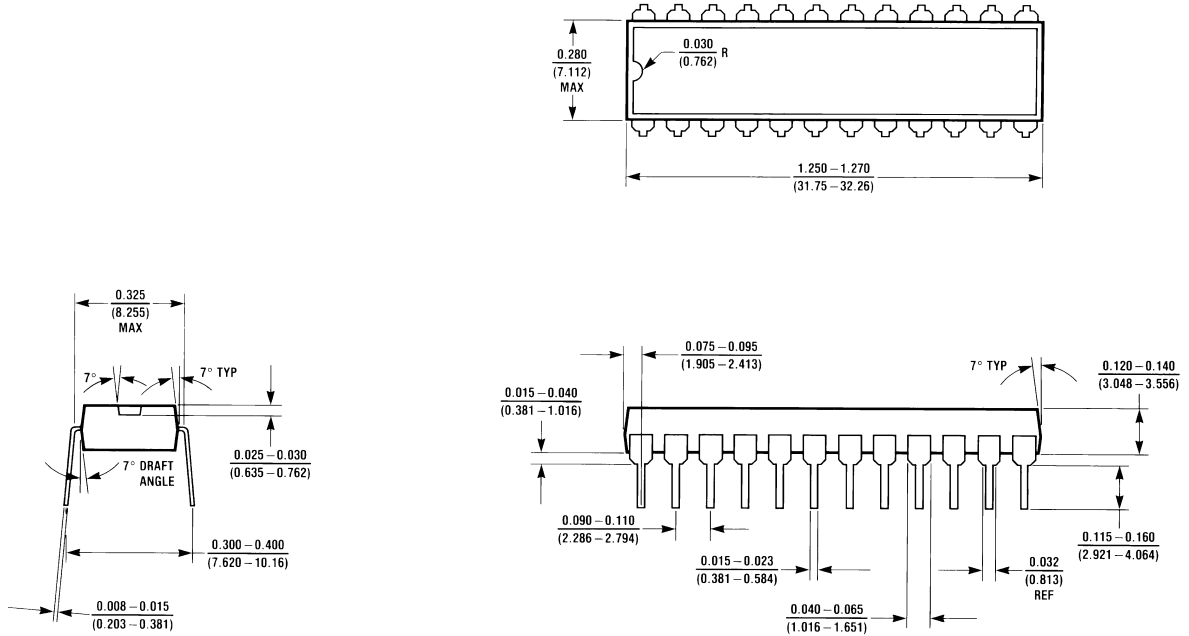

N24D (REV B)

LIFE SUPPORT POLICY

NATIONAL'S PRODUCTS ARE NOT AUTHORIZED FOR USE AS CRITICAL COMPONENTS IN LIFE SUPPORT DEVICES OR SYSTEMS WITHOUT THE EXPRESS WRITTEN APPROVAL OF THE PRESIDENT AND GENERAL COUNSEL OF NATIONAL SEMICONDUCTOR CORPORATION. As used herein:

1. Life support devices or systems are devices or systems which, (a) are intended for surgical implant into the body, or (b) support or sustain life, and whose failure to perform when properly used in accordance with instructions for use provided in the labeling, can be reasonably expected to result in a significant injury to the user.
2. A critical component is any component of a life support device or system whose failure to perform can be reasonably expected to cause the failure of the life support device or system, or to affect its safety or effectiveness.



National Semiconductor Corporation
Americas
Email: support@nsc.com

www.national.com

National Semiconductor Europe

Fax: +49 (0) 180-530 85 86
Email: europe.support@nsc.com
Deutsch Tel: +49 (0) 69 9508 6208
English Tel: +44 (0) 870 24 0 2171
Français Tel: +33 (0) 1 41 91 8790

National Semiconductor Asia Pacific Customer Response Group

Tel: 65-2544466
Fax: 65-2504466
Email: ap.support@nsc.com

National Semiconductor Japan Ltd.

Tel: 81-3-5639-7560
Fax: 81-3-5639-7507