

### FEATURES

- Wide Attenuator Gain Range (52dB) Between Transmit and Receive
- Low Voltage Operation (3V to 6V), Ideal for Line Powered Applications
- Improved Switching Sensitivity Utilizing Four Point Sensing
- Background Noise Monitors In Both Transmit and Receive Paths
- Microphone Amplifier with Adjustable Gain and Mute Feature
- Chip Disable for Power Conservation
- User Configurable Receive Channel Filter
- Dial Tone Detector
- Compatible with XR-T65119 Loudspeaker Amplifier

### APPLICATIONS

- Feature Phones
- Intercoms
- Voice Operated Switches
- Personal Notebook Computers

### GENERAL DESCRIPTION

The XR-T65118A Voice Switched Speakerphone Circuit includes all the active circuitry and control algorithms to implement an advanced hands free telephone system. The circuit includes a microphone amplifier with external gain set and muting, complimentary transmit and receive attenuators, quad peak detectors sensing signal levels at the inputs and outputs of both attenuators, and background noise monitors in both the transmit and receive channels. The receive background noise monitor is inhibited when dial tone is detected to prevent muting of the dial tone. Two line drive amplifiers in the transmit path are used with a coupling transformer to form an active hybrid network. A buffer in the receive path may be configured as a variety of filters to improve the signal quality from the line.

The XR-T65118A features 3V to 6V operation, and may be powered directly from a telephone line or an external power supply. A chip disable pin powers down the entire device and reduces operating current under idle conditions. An AGC circuit reduces receive channel gain at low supply voltages. It is also used to reduce supply current drain in the external loudspeaker and driver, which is especially useful for line powered applications. The XR-T65118A may be used as a stand alone speakerphone, connected to TIP and RING with a coupling transformer, or integrated into a handset speech network, as a building block of a feature phone.

### ORDERING INFORMATION

Part No.	Package	Operating Temperature Range
XR-T65118ACP	28 Lead 600 Mil PDIP	-20°C to +70°C
XR-T65118ACD	28 Lead (300 MIL JEDEC SOIC)	-20°C to +70°C

## BLOCK DIAGRAM

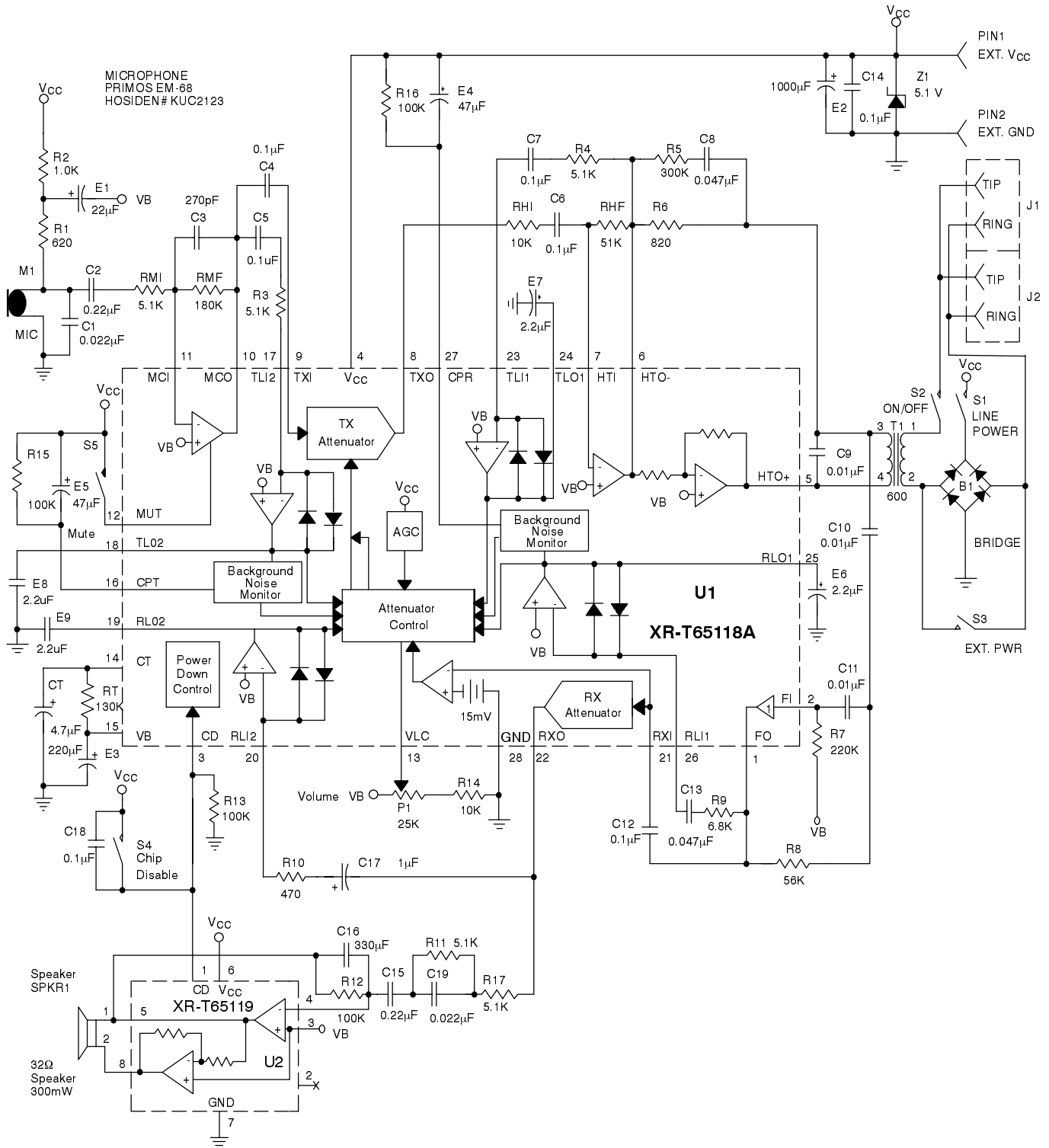
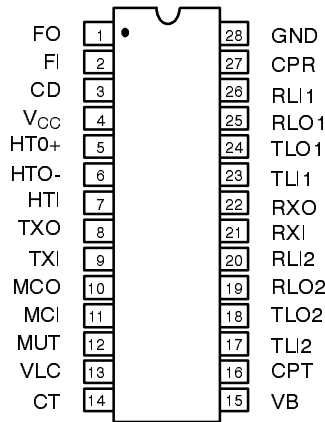
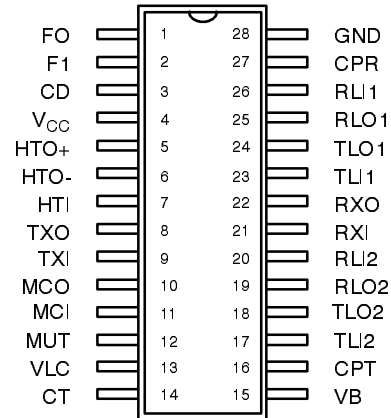

Figure 1. Block Diagram and Application Circuit

## PIN CONFIGURATION



**28 Lead PDIP (0.600")**



**28 Lead Jedec SOIC (300 mil)**

## PIN DESCRIPTION

Pin #	Symbol	Type	Description
1	FO	O	<b>Filter Output.</b> Output impedance less than 200Ω.
2	FI	I	<b>Filter Input.</b> Input impedance greater than 600kΩ.
3	CD	I	<b>Chip Disable.</b> Active high (>2V) disables IC. Low (<0.8V) sets normal operation. Input impedance is nominally 90kΩ. Refer to <i>Figure 17</i> . When in the power down mode, the microphone amplifier and hybrid amplifiers are disabled, and their outputs go into a high impedance state.
4	V <sub>CC</sub>	I	<b>Positive Supply.</b> Voltage range between 2.8V and 6.5V. An AGC circuit reduces receive gain by >25dB when V <sub>CC</sub> falls from 3.5V to 2.8V. This is desirable feature for line powered applications, where the available power is limited.
5	HTO+	O	<b>Second Hybrid Amplifier Output.</b> Gain internally set at -1.0 to provide a differential output, in conjunction with HTO-, to the hybrid transformer.
6	HTO-	O	<b>First Hybrid Amplifier Output.</b> Gain externally set. Refer to <i>Figure 1</i> .
7	HTI	I	<b>First Hybrid Amplifier Input.</b> DC level approx. VB.
8	TXO	O	<b>Transmit Attenuator Output.</b> DC level approx. VB. This signal is AC coupled to the First Hybrid Amplifier input.
9	TXI	I	<b>Transmit Attenuator Input.</b> Max. Signal level - 350mVrms. Input impedance is nominally 10kΩ.
10	MCO	O	<b>Microphone Amplifier Output.</b> Gain externally set. Refer to <i>Figure 1</i> .
11	MCI	I	<b>Microphone Amplifier Input.</b> DC level approx. VB.
12	MUT	I	<b>Mute Input.</b> Active high (>2V) mutes microphone amplifier AC gain. Low (<0.8V) sets normal operation. Input impedance is nominally 90kΩ.

## PIN DESCRIPTION (CONT'D)

Pin #	Symbol	Type	Description
13	VLC	I	<b>Receive Volume Control.</b> Sets receive channel gain. Does not affect transmit gain. When VLC=VB, receive gain is maximum. When VLC=0.3VB, gain is attenuated 35dB.
14	CT	I	<b>Response Time Adjust.</b> An RC at this pin sets the response time for the circuit to switch modes. Pin may be used to control the state of the system.
15	VB	O	<b>Reference Voltage.</b> Nominally $V_{CC}/2$ . Used as AC ground for system. Must be decoupled to GND for normal operation.
16	CPT	O	<b>Transmit Background Noise Monitor Adjust.</b> Time constant set with external RC.
17	TLI2	I	<b>2nd Transmit Level Detector Input.</b> Input of level detector, monitoring microphone amplifier output.
18	TLO2	O	<b>2nd Transmit Level Detector Output.</b> Output of level detector, monitoring microphone amplifier output.
19	RLO2	O	<b>2nd Receive Level Detector Output.</b> Output of level detector, monitoring loudspeaker amplifier output.
20	RLI2	I	<b>2nd Receive Level Detector Input.</b> Input of level detector, monitoring loudspeaker amplifier output.
21	RXI	I	<b>Receive Attenuator And Dial Tone Detector Input.</b> Max input level = 350mV(rms). Input impedance nominally 10k $\Omega$
22	RXO	O	<b>Receive Attenuator Output.</b> DC level nominally VB.
23	TLI1	I	<b>1st Transmit Level Detector Input.</b> Input of level detector, monitoring hybrid amplifier output.
24	TLO1	O	<b>1st Transmit Level Detector Output.</b> Output of level detector, monitoring hybrid amplifier output.
25	RLO1	O	<b>1st Receive Level Detector Output.</b> Output of level detector, monitoring received line signal.
26	RLI1	I	<b>1st Receive Level Detector Input.</b> Input of level detector, monitoring received line signal.
27	CPR	O	<b>Receive Background Noise Monitor Adjust.</b> Time constant set with external RC.
28	GND		<b>Ground Pin (0V)</b>

## DC ELECTRICAL CHARACTERISTICS

Test Conditions:  $T_A = 25^\circ\text{C}$ ,  $V_{CC} = 5.0\text{V} \pm 10\%$ ,  $CD < 0.8\text{V}$  unless noted otherwise.

Symbol	Parameter	Min.	Typ.	Max.	Unit	Condition
<b>General</b>						
$I_{VB}$	VB Output Current			500	$\mu\text{A}$	
VLC	Volume Control Input Voltage	0.3VB		VB	V	
$V_{IN}$	RX/TX Attenuator Input Voltage			350 500	mVrms mVp	
$G_{AMP}$	Microphone, Hybrid Amp Closed Loop Gain			40	dB	
$I_{OUT}$	Amplifier Output Current					
	@RXO, TXO	-2		2	mA	
	@MCO	-1		1	mA	
	@HTO+, HTO-	-5		5	mA	
<b>Power Supply</b>						
$V_{CC}$	Supply Voltage	3.5		6.5	V	For Normal Operation
$I_{CC}$	Supply Current		5.4	6.5	mA	$V_{CC} = 6.5\text{V}$ , $CD < 0.8\text{V}$
$I_{PD}$	Power Down Supply Current		0.4	0.6	mA	$V_{CC} = 6.5\text{V}$ , $CD > 2.0\text{V}$
$R_{CD}$	CD Input Resistance	50	90		$k\Omega$	
$V_{CDH}$	CD Input Voltage High	2.0			V	
$V_{CDL}$	CD Input Voltage Low			0.8	V	
VB	Reference Voltage	1.8	2.2	2.4	V	$V_{CC} = 5.0\text{V}$
			1.4		V	$V_{CC} = 3.5\text{V}$
$R_{VB}$	Reference Output Resistance		400		$\Omega$	$I_{VB} = 1\text{mA}$
$VB_{PSR}$	VB Power Supply Rejection		60		dB	$CVB = 200\mu\text{F}$ $F = 1\text{kHz}$
<b>Receive Attenuator</b>						
$G_{RXL}$	Receive Gain	4.0	6.0	8.0	dB	$V_{CC} = 3.5\text{V}$ , $R_{XI} = 150\text{mV}$
$G_{RXH}$	Receive Gain	4.0	6.0	8.0	dB	$V_{CC} = 5.0\text{V}$ , $R_{XI} = 150\text{mV}$
$G_{RXI}$	Idle Mode	-22	-20	-17	dB	$R_{XI} = 150\text{mV}$
$G_{RXD1}$	RX Gain Change	-0.5		0.5	dB	$3.5 < V_{CC} < 5.0\text{V}$
$G_{RXD2}$	RX Gain Change $V_{CC}$ AGC		-25	-15	dB	$2.8 < V_{CC} < 5.0\text{V}$
$G_{RXD3}$	RX Gain Range	49	52	54	dB	RX to TX mode.
$A_{VLC}$	Volume Control Range	22			dB	RX Mode; $0.3VB < V_{VLC} < VB$
$V_{RXO}$	RXO DC Voltage		VB		V	RX Mode
$V_{RXOD}$	RXO DC Voltage Change	-150		150	mV	RX to TX mode.
$V_{RXOH}$	RXO Output High Voltage	3.7			V	$I_{OUT} = -1\text{mA}$ , $R_{XI} = VB + 1.5\text{V}$
$V_{RXOL}$	RXO Output Low Voltage			VB-1	V	$I_{OUT} = +1\text{mA}$ , $R_{XI} = VB - 1\text{V}$
$R_{RXI}$	RXI Input Resistance	7.0	10.0	14.0	$k\Omega$	

## DC ELECTRICAL CHARACTERISTICS (CONT'D)

Symbol	Parameter	Min.	Typ.	Max.	Unit	Condition
<b>Transmit Attenuator</b>						
G <sub>TX</sub>	Transmit Gain	4.0	6.0	8.0	dB	V <sub>CC</sub> = 5.0V, TXI = 150mV
G <sub>TXI</sub>	Idle Mode	-22	-20	-17	dB	TXI = 150mV
G <sub>TXD</sub>	Gain Range	49	52	54	dB	TX to RX Mode
V <sub>TXO</sub>	TXO DC Voltage		VB		V	RX Mode
V <sub>TXOD</sub>	TXO DC Voltage Change	-150		150	mV	TX to RX Mode
V <sub>TXOH</sub>	TXO Output High Voltage	3.7			V	I <sub>OUT</sub> = -1mA, TXI = VB + 1.5V
V <sub>TXOL</sub>	TXO Output Low Voltage			VB-1	V	I <sub>OUT</sub> = +1mA, TXI = VB - 1V
G <sub>TR</sub>	Gain Tracking		± 0.1		dB	GRX+GTX, @TX,RX, Idle
R <sub>TXI</sub>	TXI Input Resistance	7.0	10.0	14.0	kΩ	TXI < 350 mVrms
<b>Attenuator Control</b>						
V <sub>CT</sub>	CT Voltage RX Mode	160	240	320	mV	VLC = VB
	CT Voltage Idle Mode	-100	0	100	mV	
	CT Voltage TX Mode	-320	-240	-160	mV	
I <sub>CTR</sub>	CT Source Current	-85	-60	-40	μA	
I <sub>CTT</sub>	CT Sink Current	40	60	85	μA	
I <sub>CTS</sub>	CT Idle		0		μA	
I <sub>VLC</sub>	VLC Input Current	-60			nA	
V <sub>DT</sub>	Dial Tone Threshold	10	15	20	mV	
<b>Microphone Amplifier (VMUT&lt;0.8V, AVCL=31dB unless noted otherwise)</b>						
V <sub>OSM</sub>	Output Offset (VMCO-VB)	-50		50	mV	RF 180kΩ
A <sub>VOLM</sub>	Open Loop Gain	70	80		dB	f < 100Hz
GBW <sub>M</sub>	Gain Bandwidth		1.0		MHz	
V <sub>MCOH</sub>	Output High Voltage	3.7			V	I <sub>OUT</sub> = +1mA
V <sub>MCOL</sub>	Output Low Voltage			200	mV	I <sub>OUT</sub> = -1mA
I <sub>BM</sub>	Input Bias Current		-40		nA	@MC1
G <sub>MUT</sub>	Muting Gain	-55			dB	f = 1kHz; VMUT = 2.0V
			-68		dB	300Hz < f < 10kHz
R <sub>MUT</sub>	MUT Input Resistance	50	70		kΩ	V <sub>CC</sub> = 6.5V, VMUT = 6.5V
V <sub>MUTH</sub>	MUT Input High	2.0		V <sub>CC</sub>	V	
V <sub>MUTL</sub>	MUT Input Low	0		0.8	V	
THD <sub>M</sub>	Distortion		0.15		%	300Hz < f < 10kHz

## DC ELECTRICAL CHARACTERISTICS (CONT'D)

Symbol	Parameter	Min.	Typ.	Max.	Unit	Condition
<b>Hybrid Amplifier</b>						
H <sub>VOS</sub>	HTO- Offset (VHTO- - VB)	-20		20	mV	RF = 51kΩ
H <sub>BVOS</sub>	HTO- to HTO+ Offset	-30		30	mV	RF = 51kΩ
A <sub>VOLH</sub>	Open Loop Gain	60	80		dB	HTI to HTO-
GBW <sub>H</sub>	Gain Bandwidth		1.0		MHz	
A <sub>VCLH</sub>	Close Loop Gain	-0.35	0	+0.35	dB	HTO- to HTO+
I <sub>BH</sub>	Input Bias Current		-30		nA	@HTI
V <sub>HT-H</sub>	HTO- High Voltage	3.7			V	I <sub>OUT</sub> = -5mA
V <sub>HT-L</sub>	HTO- Low Voltage			250	mV	I <sub>OUT</sub> = 5mA
V <sub>HT+H</sub>	HTO+High Voltage	3.7			V	I <sub>OUT</sub> = -5mA
V <sub>HT+L</sub>	HTO+Low Voltage			450	mV	I <sub>OUT</sub> = 5mA
THD <sub>H</sub>	Distortion		0.3		%	300Hz < f < 10kHz
<b>Level Detectors And Background Noise Monitors</b>						
I <sub>TH</sub>	TX/RX Switch Threshold <sup>1</sup>	0.8	1.0	1.2		
I <sub>LSO</sub>	Source Current @RLO1, RLO2, TLO1, TLO2		-2.0		mA	
I <sub>LSI</sub>	Sink Current @RLO1, RLO2, TLO1, TLO2		4.0		μA	
R <sub>CP</sub>	CPR, CPT Output Resistance		35		Ω	I <sub>OUT</sub> = 1.5mA
I <sub>CPLK</sub>	CPR, CPT Leakage Current		-0.2		μA	
<b>Filter</b>						
F <sub>O</sub> V <sub>OS</sub>	Voltage Offset @ FO (VFO-VB)	-100	0	100	mV	RF = 220kΩ
V <sub>FIN</sub>	Maximum Input Level			350 500	mVrms mVp	
I <sub>FO</sub>	FO Sink Current	150	260	400	μA	
I <sub>FI</sub>	FI Bias Current		-50		nA	
<b>System Distortion (f=1kHz)</b>						
THD <sub>R</sub>	RX Mode, From FI to RXO		0.5	3.0	%	FO to RXI
THD <sub>T</sub>	TX Mode, From MCI to HTO- and HTO+		0.8	3.0	%	

**Note**

<sup>1</sup> I<sub>RL1</sub> / I<sub>TL1</sub> or I<sub>RL2</sub> / I<sub>TL2</sub> with I<sub>TL1</sub>, I<sub>TL2</sub> = 20μA to cause TX to RX switching.

Specifications are subject to change without notice

## ABSOLUTE MAXIMUM RATINGS

Supply Voltage (Pin 4) ..... -0.5V to 7.0V  
 Maximum Voltage at Any Input Pin ..... (V<sub>CC</sub> +0.5V)

Minimum Voltage at Any Input Pin .... (GND -0.5V)  
 Storage Temperature Range ..... -65°C to +150°C

## SYSTEM DESCRIPTION

While using a handset, talking and listening can occur simultaneously, while in a speakerphone it can only occur in one direction at a time (half duplex). This is a fundamental difference between a speakerphone and handset. Higher path gains and acoustic coupling between the loudspeaker and microphone in a speakerphone would result in oscillation if full duplex operation is attempted. A handset, however, has lower path gains and considerably less acoustic coupling between the mouthpiece and earpiece which makes it less prone to oscillation. Earlier speakerphone designs achieved half duplex operation using a push to “talk” switch. The XR-T65118A implements voice controlled switching to achieve “hands free” operation by selecting the channel with speech presence. This is done by switching attenuators such that active channel gain is maximized while idle channel gain is minimized. Thus maintaining a loop gain less than unity. By providing fast response time speech detectors, unwanted word clipping is decreased and the interference in conversation due to circuit switching is reduced. Background noise monitoring circuits are included in both channels to reduce the gain of a noisy channel and allow switching to the other channel while detecting speech. *Figure 1* shows a block diagram and a typical application circuit for the device.

## ATTENUATORS

Complimentary attenuators are included in the transmit and receive paths. This in conjunction with the control block implements half duplex operation. When one attenuator is at maximum gain (+6.0dB) the other is at maximum attenuation (-46dB). The sum of the absolute value of the gains remains constant at 40dB, within an error band of +0.1dB.

The attenuators are non-inverting and have a 3dB point around 100kHz, with a nominal input impedance of 10kΩ (see *Figure 2*). Input level should be kept less than 350mV/rms to avoid distortion. Note that attenuator input level is independent of volume control setting and adjustment of the volume control merely affects output levels. Clamping diodes at the attenuator inputs limit negative going signals and set a maximum for the negative output swing. RXO Low Voltage and TXO Low Voltage are specified accordingly. Output impedance is typically less than 10Ω until output current limiting (around 2.5mA) occurs.

Operation of the attenuators is controlled by the CT (pin 14) output of the control block. The voltage present at this pin may be used to monitor system operation. The state of the Speakerphone (RX/TX) may be controlled by sourcing or sinking current into this pin by connecting a 20k resistor to V<sub>CC</sub> (RX) or ground (TX). (See *Table 1*.)

CT Voltage, (Referred to VB)	Operating Mode
+240mV	RX (attenuator at +6dB)
-240mV	TX (attenuator at +6dB)
0V	IDLE (both attenuators at -20dB)

**Table 1. Operating Mode**

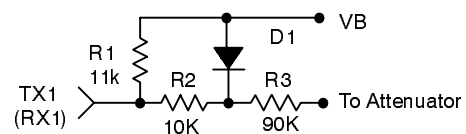

**Figure 2. Attenuator Input Circuit**

The inputs to the control block are seven:  
 2 from the comparators operated by the level detector,  
 2 from the background noise monitor,  
 1 from the volume control,  
 1 from the dial-tone detector and  
 1 from the AGC circuit.

A single output of the control block controls the receive or transmit attenuators. Out of the level detectors and noise monitors come four inputs (A1-A4) to the attenuator control block which is used to set the states of the speakerphone. These are:

- (1) “**Transmit**”: Transmit attenuator is fully on (+6dB) and receive attenuator is at (-46dB) gain.
- (2) “**Receive**”: both attenuators are controlled by the volume control. At maximum, the receive attenuator is at +6dB and the transmit attenuator is at -46dB gain.
- (3) “**Idle**”: speech has stopped in both receive and transmit paths. The attenuators are then slowly switched (1 second) to the idle mode.



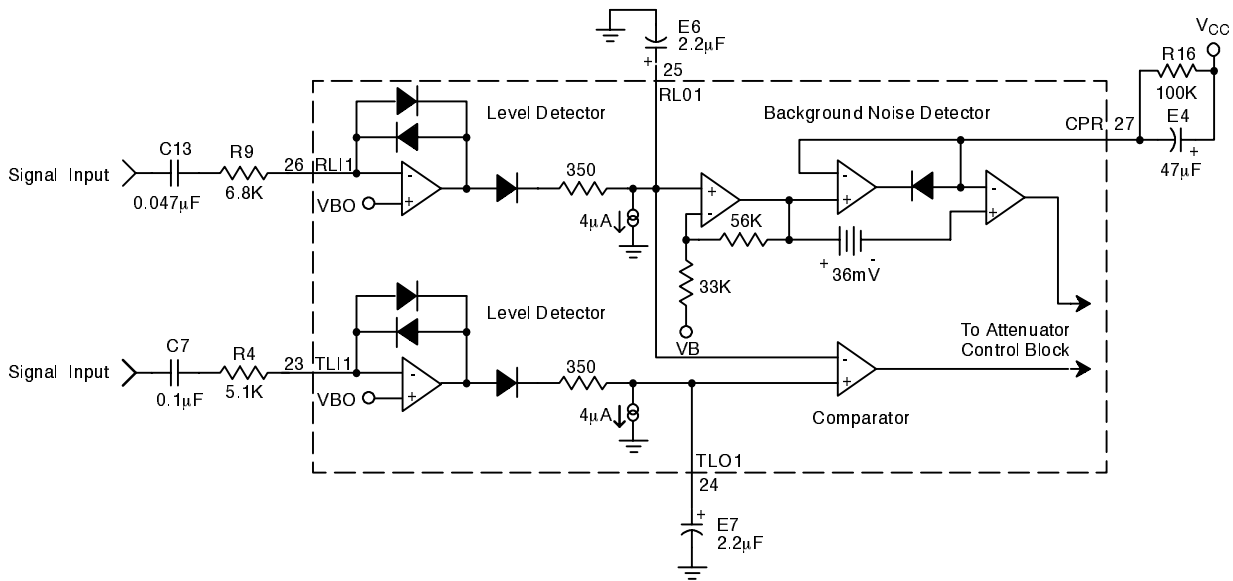

Figure 3. Level Detectors

**Switching Characteristics**

**Switch to Transmit:** Both of the transmit level detectors sense higher signal levels relative to the respective receive level detectors (TLI1 vs. RLI1, and TLI2 vs. RLI2) and the transmit background monitor indicates the presence of speech.

**Switch to Receive:** Both of the receive level detectors indicate higher signal levels relative to the respective transmit levels, and the receive background noise monitor indicates the presence of speech.

**Switch to Idle:** This condition occurs when both talkers are silent or when noise occurs in both channels.

The time required to switch between transmit, receive and idle is determined by the components at the CT (pin 14). (See Figure 4).

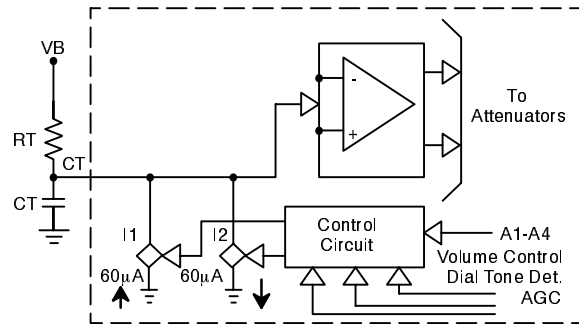

Figure 4. Attenuator Control Block Circuit

**Switch to Receive Mode:** I1 is on (I2 is off). CT charges to +240mV with respect to VB. Internal clamping prevents overcharging.

**Switch to Transmit Mode:** I2 is turned on (I1 is off). CT charges to -240mV with respect to VB. Internal clamp prevents undercharging.

**Switch to Idle Mode:** The current sources are turned off. The capacitor CT discharges to VB with a time constant of RT \* CT.

## LEVEL DETECTORS

The XR-T65118A uses four level detectors, two in the transmit path, two in the receive path. The level detectors are positioned at the inputs of the transmit and receive attenuators and at the outputs of the loudspeaker and hybrid amplifiers. The level detectors feed two comparators, which provide inputs to the attenuator control block. Each level detector is constructed from a high gain amplifier with back to back diodes as feedback. The level detectors feed two comparators, which provide inputs to the attenuator control block. Each level detector is constructed from a high gain amplifier with back to back diodes as feedback. The resulting nonlinear response allows operation over a wide dynamic range of speech levels. Refer to *Figure 10*, *Figure 11*, and *Figure 12* for amplifier AC and DC characteristics. The sensitivity of the peak detectors is adjustable with an external capacitor and resistor at the input of each amplifier (TLI1, TLI2, RLI1, RLI2). A storage capacitor, connected to the amplifier output, is charged via an internal diode and 350Ω limiting resistor, producing a DC level proportional to the AC input. The capacitor voltage has fast attack and slow decay times, defined by the internal 350Ω resistor, and a 4μA current source. The storage capacitors of each level detector should be matched to within 10% to prevent timing problems.

## BACKGROUND NOISE MONITOR

There are two background noise monitors; one for the receive path and the other for the transmit path. The main purpose of this circuitry is to distinguish speech (generally bursty in nature) from background noise (generally constant signal level). The receive background monitor input is taken from the RLI1-RLO1 level detector (i.e. TLI2-TLO2 for the transmit side). Refer to *Figure 1*. The noise level is established by storing a DC voltage representative of the noise level in a capacitor (R15, E5 or R16, E4). The voltages at these pins have slow rise times and fast decay times determined by the external network. For example, if the signal at RLI1 (TLI2) changes slowly, then the voltage at CPR or CPT will remain more positive than at the non-inverting input of the output comparator indicating noise. If speech is present, the voltage at the non-inverting input rises quicker than the voltage at the inverting input, which causes the output to change. As shown in *Figure 3*, a 36mV offset voltage of the background noise monitor keeps the comparator from changing state unless the speech level exceeds the background noise level by approximately 4dB. The time constant of the external RC (4.7 sec) determines the response time relative to background noise variations.

## VOLUME CONTROL

The volume control affects the attenuators of the receive side only and is referenced to VB. The idle and the transmit modes are not affected.

When in the receive mode and whenever VLC is equal to VB, the receive attenuator gain is set at +6dB (refer to *Figure 1*). As the voltage on VLC drops below VB, the gain of the receive path is reduced and that of the transmit path is increased, keeping their sum constant. The change of voltage at VLC is reflected by the voltage at CT which change correspondingly. The volume control setting does not affect the maximum attenuator input signal at which noticeable distortion occurs. The bias current of the VLC pin is typically 60nA and is not affected by the VLC voltage or the VCC setting.

## DIAL TONE DETECTOR

The Dial Tone Detector is a comparator whose inputs are RXI and VB. The purpose of this circuit is to prevent the dial tone from fading away, as the circuit would tend to switch to the idle mode after some time. When in the receive mode, and the incoming signal is greater than 15mV, the comparator changes state, and prevents the receive VCA from going into the idle mode. By doing this, the dial tone remains at the normally expected full level. The receive attenuator will then be set by the volume control.

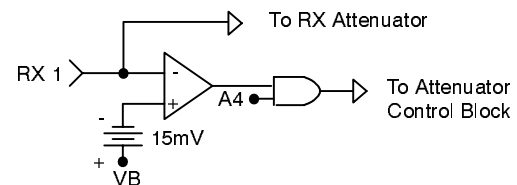

Figure 5. Dial Tone Detector

## AGC

This circuitry reduces the receive gain, whenever the supply voltage (VCC) falls below 3.5V. The purpose of this feature is to prevent erratic operation by reducing the speaker power. Whenever the supply voltage falls below 3.5V, the gain of the receive attenuator is reduced according to the graph of *Figure 14*. The transmit path attenuation changes such that the sum of the transmit and receive gains remains constant. This is a desirable feature when the speakerphone is connected to a

line-powered network, where the available power is limited.

**MICROPHONE AMPLIFIER**

This amplifier has a typical open loop gain of 80dB ( $f < 100\text{Hz}$ ) and a gain bandwidth of 1.5 MHz. The output stage is designed to maximize phase margin and gain bandwidth with an all NPN output configuration. The maximum p-p output swing is typically 1.0V less than  $V_{CC}$  with an output impedance of  $< 10\Omega$  until the current limit is reached (1.5mA). The MCI bias current is typically 40nA. Internally, the non-inverting input of the amplifier is connected to VB.

The muting function reduces the gain of the amplifier by approximately 68dB (with  $R_{MI} = 5.1\text{k}\Omega$ ). This is done by shorting the output to the non-inverting input. The mute input threshold is 1.5V typically and should be kept at ground when not in use.

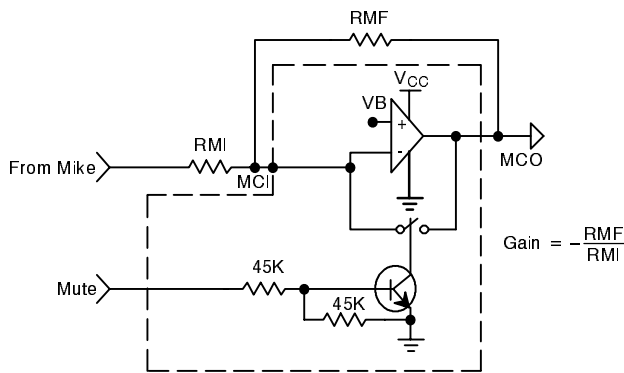

**Figure 6. Microphone Amplifier and Mute**

**HYBRID AMPLIFIERS**

These amplifiers, together with a transformer are intended to provide the two-to-four wire conversion necessary to interface to a telephone line. The gain of the first amplifier is set by the external resistor ratio of  $R_{HF}/R_{HI}$  as shown in *Figure 1*. The output of the first amplifier drives the second amplifier whose gain is internally set at -1.0. Similarly to the microphone amplifier, the hybrid amplifiers are designed with an all NPN output stage in order to maximize phase and gain margin. The open loop gain and frequency response is similar to the microphone amplifier. The maximum peak to peak voltage swing at the output is 1.2V less than  $V_{CC}$

The output current capability is 5mA. The bias current at HTI is typically 30nA.

**FILTER**

The filter circuit can be configured as a high-pass, low-pass or band-pass filter depending on the selection of the external components. The circuitry internal to the XR-T65118A is a buffer with a high input impedance ( $600\text{k}\Omega$ ) and low output impedance ( $200\Omega$ ). When configured as in *Figure 7*, the filter will remove 60Hz hum which can be picked up by telephone lines.

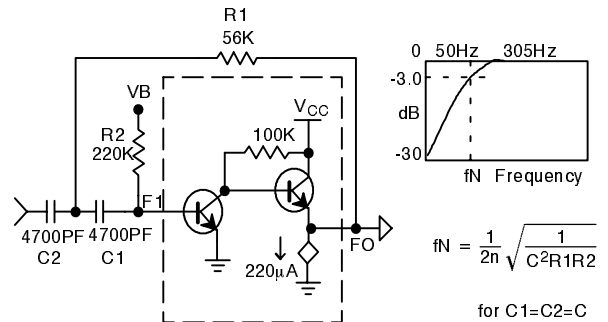

**Figure 7. High Pass Filter**

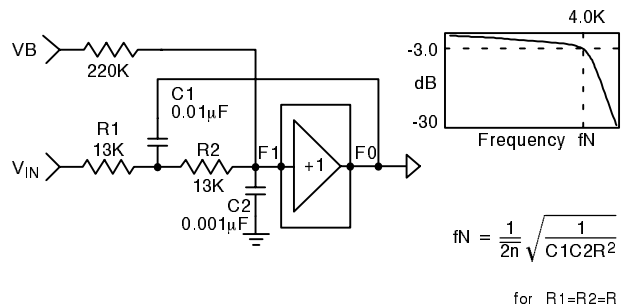

**Figure 8. Low Pass Filter**

A low pass filter as shown in *Figure 8*, can be used to roll off the high end frequencies in the receive circuit, which helps protect against acoustic feedback problems. To achieve a band-pass filter response, a coupling capacitor at the input to the low-pass filter can be used.

The supply voltage of the XR-T65118A should be kept between 3.5V and 6.5V for normal operation and down to 2.8V in reduced power operation (see *Figure 14* and the AGC section). The graph in *Figure 17* shows the power supply current necessary for both power-up and power-down modes. The output voltage at VB (pin 15) is approximately  $(V_{CC} - 0.7\text{V})/2$  and provides the AC ground

for the system. A capacitor connected to VB together with the output impedance (400Ω typically), forms a low-pass filter to improve the power supply rejection. The choice of this capacitor is application dependent and based on whether the circuit is powered by the telephone line or an external power source. The amount of supply rejection is important because VB biases the microphone and hybrid amplifiers. Also, the supply rejection of these amplifiers is directly proportional to the rejection of  $V_B$ . The IC can be

powered down (pin 3) to conserve power and/or for muting purposes (normal operation  $CD < 0.8V$ ; power down mode  $2.0V < CD < V_{CC}$ ). When in the power down mode, the microphone and hybrid amplifiers are disabled, and their outputs go into a high impedance state. The CD pin has an input impedance of 90kΩ, a threshold voltage of 1.5V and should be kept grounded (normal operation) when not in use, or at  $V_{CC}$  when in a power down mode.

Parameter	Typical Value @ 25°C	Typical Change -20°C to +70°C
$V_{CC}$ Supply Current (CD=0.8V)	5.4mA	-0.076%/°C
$V_{CC}$ Supply Current (CD=2.0V)	460μA	-0.27%/°C
VB Output Voltage	2.2V	0.054%/°C
Attenuator Gain (Max Gain)	6.1dB	-0.0021dB/°C
Attenuator Gain (Max Attenuation)	-45.7dB	-0.0004dB/°C
Attenuator Input Resistance @ TXI, RXI	9.9kΩ	0.46%/°C
Dial Tone Detect Threshold	15.5mV	0.034mV/°C
CT Source / Sink Current	69.6μA	0.29%/°C
Microphone / Hybrid Amplifier Offset	-1.4mV	0.02mV/°C
Hybrid Closed Loop Gain (HTO- to HTO+)	-0.06dB	-0.32%/°C

**Table 2. Temperature Characteristics**

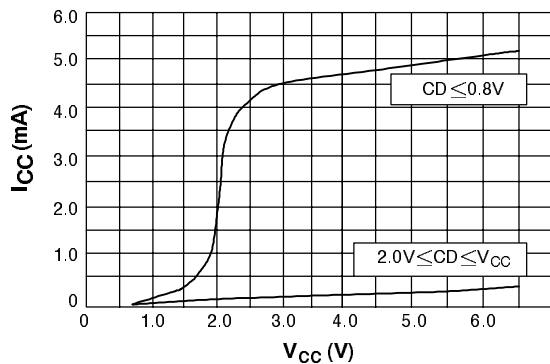

**Figure 9. Supply Current vs. Supply Voltage**

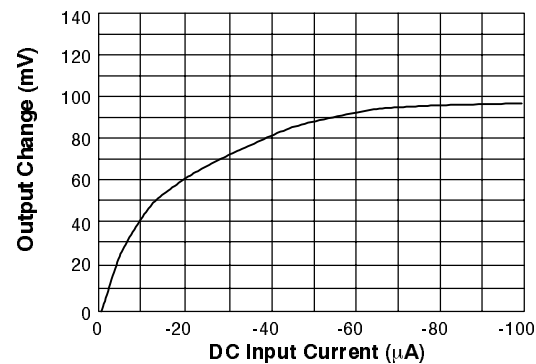

**Figure 10. Level Detector DC Transfer Characteristics**

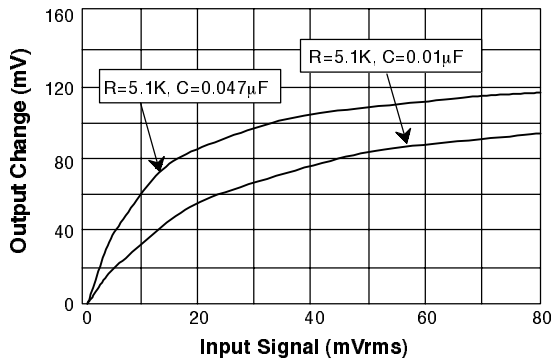

**Figure 11. Level Detector AC Transfer Characteristics**

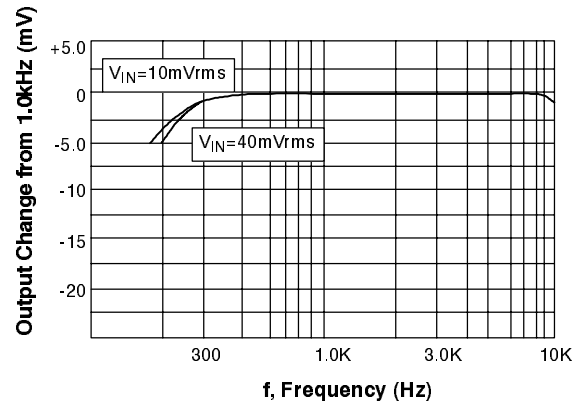

**Figure 12. Level Detector AC Transfer Characteristics vs. Frequency**

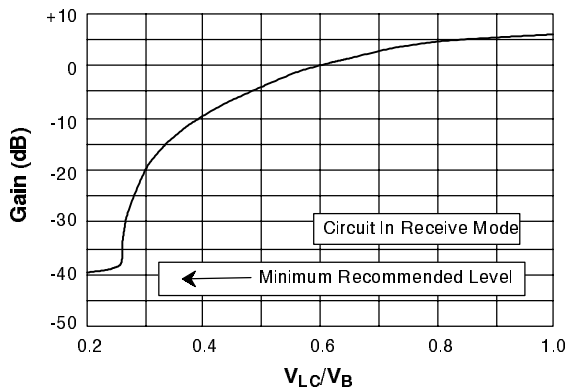

**Figure 13. Receive Attenuator vs. Volume Control**

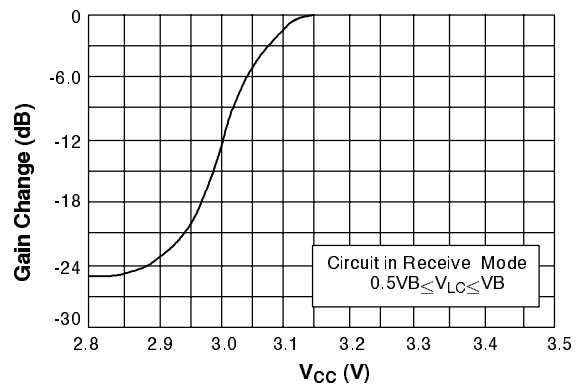

**Figure 14. Receive Attenuation Gain vs.  $V_{CC}$**

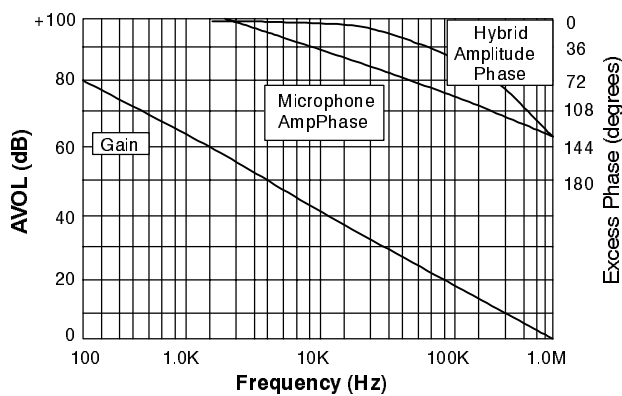

**Figure 15. Microphone Amplifier and 1st Hybrid Amplifier Open Loop Gain and Phase**

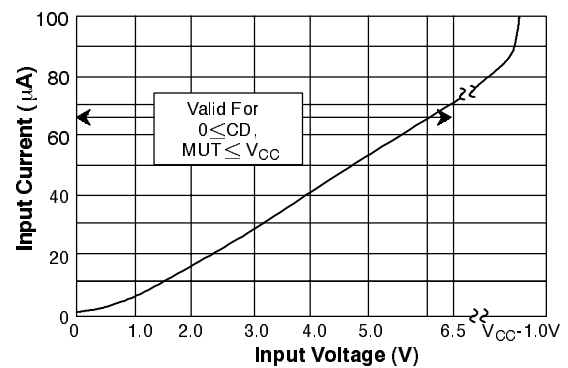

**Figure 16. Input Characteristics @ CD, Mut**

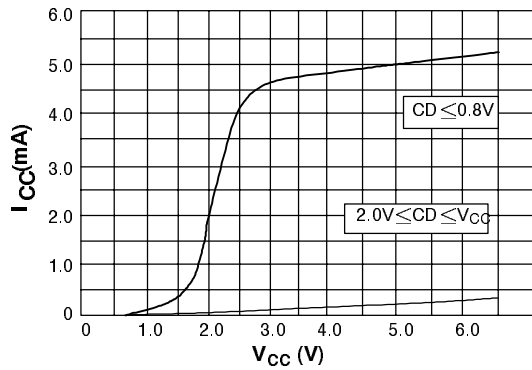

Figure 17. Supply Current vs. Supply Voltage

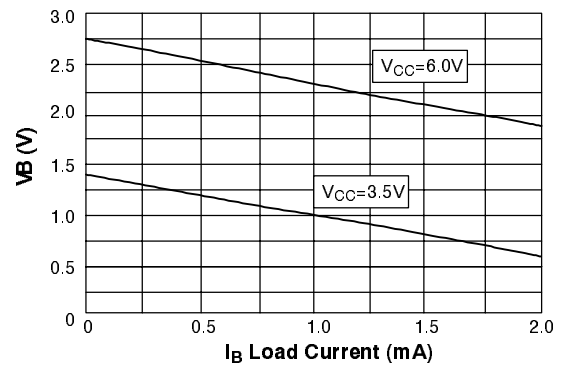

Figure 18. VB Output Characteristics

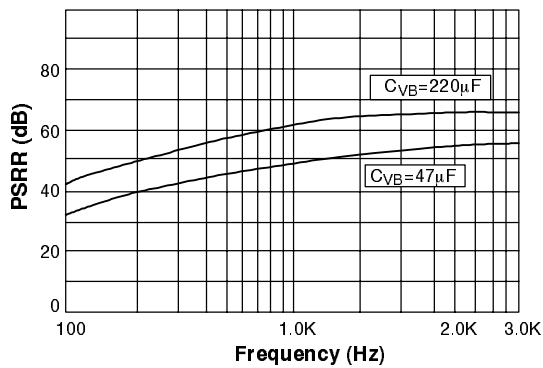

Figure 19. VB Power Supply Rejection vs. Frequency and VB Capacitor

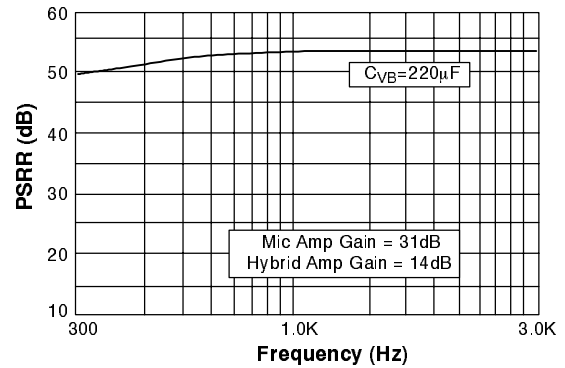

Figure 20. Power Supply Rejection of the Microphone and Hybrid Amplifiers

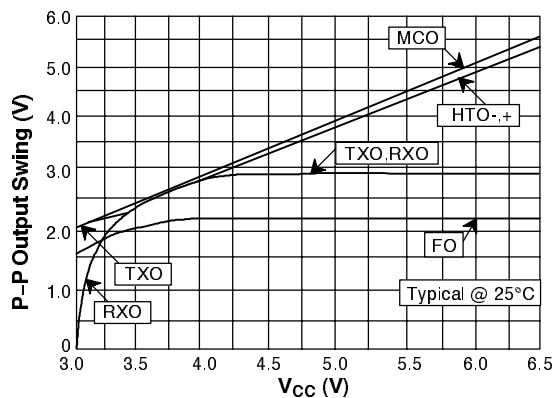
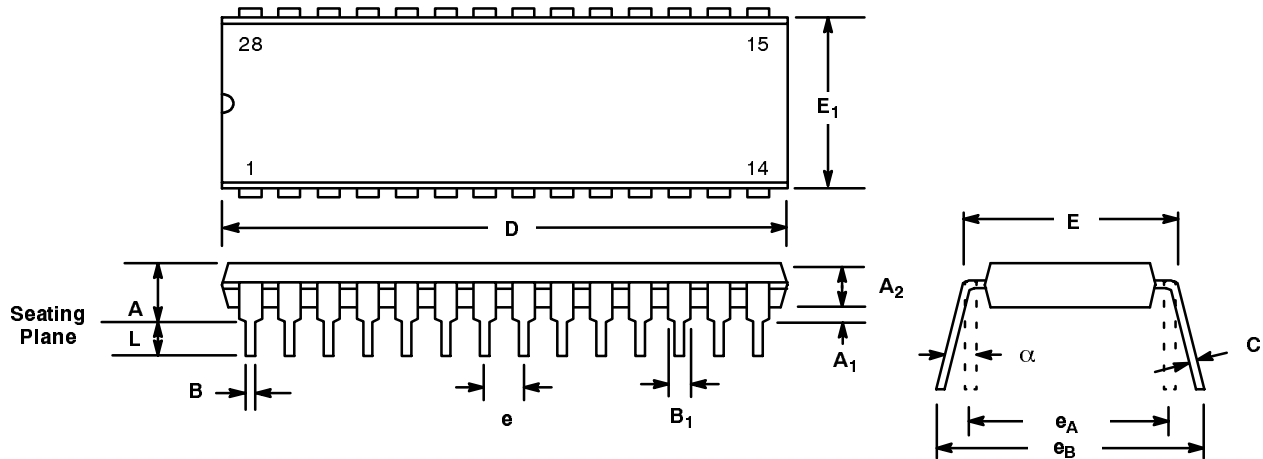

Figure 21. Typical Output Swing vs. V<sub>CC</sub>

**28 LEAD PLASTIC DUAL-IN-LINE  
(600 MIL PDIP)**

*Rev. 1.00*



SYMBOL	INCHES		MILLIMETERS	
	MIN	MAX	MIN	MAX
A	0.160	0.250	4.06	6.35
A <sub>1</sub>	0.015	0.070	0.38	1.78
A <sub>2</sub>	0.125	0.195	3.18	4.95
B	0.014	0.024	0.36	0.56
B <sub>1</sub>	0.030	0.070	0.76	1.78
C	0.008	0.014	0.20	0.38
D	1.380	1.565	35.05	39.75
E	0.600	0.625	15.24	15.88
E <sub>1</sub>	0.485	0.580	12.32	14.73
e	0.100 BSC		2.54 BSC	
e <sub>A</sub>	0.600 BSC		15.24 BSC	
e <sub>B</sub>	0.600	0.700	15.24	17.78
L	0.115	0.200	2.92	5.08
α	0°	15°	0°	15°

*Note: The control dimension is the inch column*

## 28 LEAD SMALL OUTLINE (300 MIL JEDEC SOIC)

Rev. 1.00

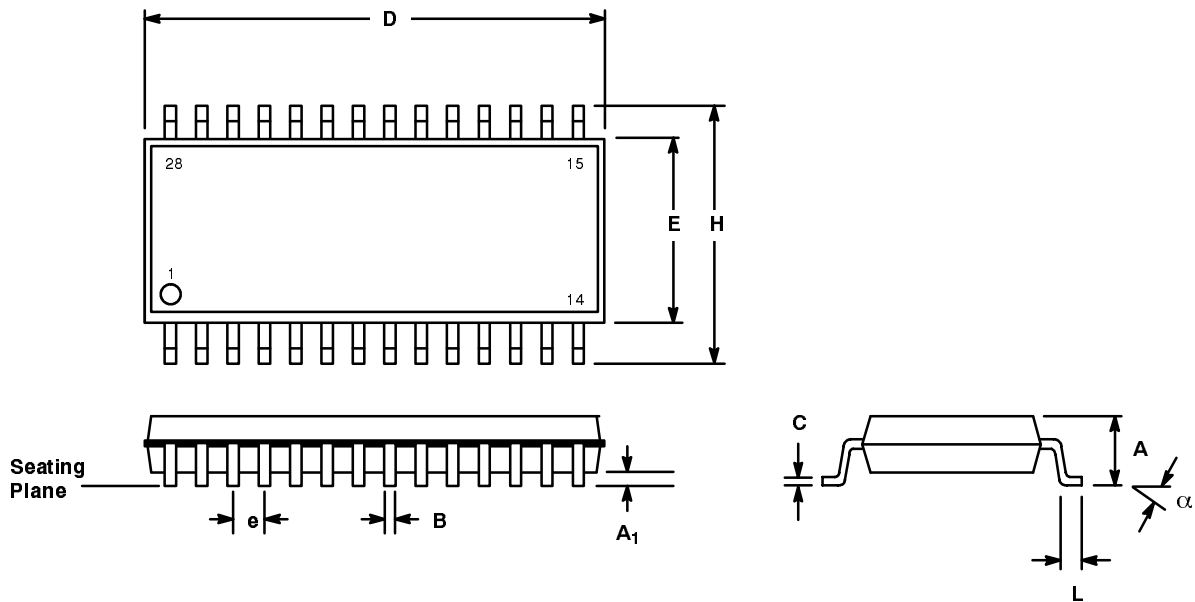

SYMBOL	INCHES		MILLIMETERS	
	MIN	MAX	MIN	MAX
A	0.093	0.104	2.35	2.65
A1	0.004	0.012	0.10	0.30
B	0.013	0.020	0.33	0.51
C	0.009	0.013	0.23	0.32
D	0.697	0.713	17.70	18.10
E	0.291	0.299	7.40	7.60
e	0.050 BSC		1.27 BSC	
H	0.394	0.419	10.00	10.65
L	0.016	0.050	0.40	1.27
$\alpha$	0°	8°	0°	8°

Note: The control dimension is the millimeter column



## NOTICE

EXAR Corporation reserves the right to make changes to the products contained in this publication in order to improve design, performance or reliability. EXAR Corporation assumes no responsibility for the use of any circuits described herein, conveys no license under any patent or other right, and makes no representation that the circuits are free of patent infringement. Charts and schedules contained here in are only for illustration purposes and may vary depending upon a user's specific application. While the information in this publication has been carefully checked; no responsibility, however, is assumed for inaccuracies.

EXAR Corporation does not recommend the use of any of its products in life support applications where the failure or malfunction of the product can reasonably be expected to cause failure of the life support system or to significantly affect its safety or effectiveness. Products are not authorized for use in such applications unless EXAR Corporation receives, in writing, assurances to its satisfaction that: (a) the risk of injury or damage has been minimized; (b) the user assumes all such risks; (c) potential liability of EXAR Corporation is adequately protected under the circumstances.

Copyright 1991 EXAR Corporation  
Datasheet June 1997

Reproduction, in part or whole, without the prior written consent of EXAR Corporation is prohibited.