

# LM2611

## 1.4MHz Cuk Converter

### General Description

The LM2611 is a current mode, PWM inverting switching regulator. Operating from a 2.7 - 14V supply, it is capable of producing a regulated negative output voltage of up to  $-(36 \cdot V_{IN(MAX)})$ . The LM2611 utilizes an input and output inductor, which enables low voltage ripple and RMS current on both the input and the output. With a switching frequency of 1.4MHz, the inductors and output capacitor can be physically small and low cost. High efficiency is achieved through the use of a low  $R_{DS(ON)}$  FET.

The LM2611 features a shutdown pin, which can be activated when the part is not needed to lower the  $I_q$  and save battery life. A negative feedback (NFB) pin provides a simple method of setting the output voltage, using just two resistors. Cycle-by-cycle current limiting and internal compensation further simplify the use of the LM2611.

The LM2611 is available in a small SOT23-5 package. It comes in two grades:

	Grade A	Grade B
Current Limit	1.2A	0.9A
$R_{DS(ON)}$	0.5 $\Omega$	0.7 $\Omega$

### Features

- 1.4MHz switching frequency
- Low  $R_{DS(ON)}$  DMOS FET
- 1mVp-p output ripple
- -5V at 300mA from 5V input
- Better regulation than a charge pump
- Uses tiny capacitors and inductors
- Wide input range: 2.7V to 14V
- Low shutdown current: <1 $\mu$ A
- 5-lead SOT-23 package

### Applications

- MR Head Bias
- Digital camera CCD bias
- LCD bias
- GaAs FET bias
- Positive to negative conversion

### Typical Application Circuit

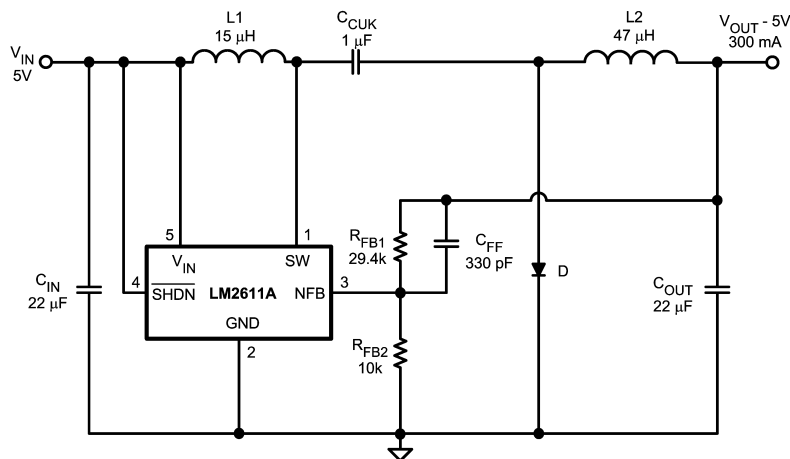

$C_{IN}$ : TAIYO YUDEN X5R JMK325BJ226MM  
 $C_{CUK}$ : TAIYO YUDEN X5R EMK316BJ105MF  
 $C_{OUT}$ : TAIYO YUDEN X5R JMK325BJ226MM  
 D: ON SEMICONDUCTOR MBR0520  
 L1: SUMIDA CR32-150  
 L2: SUMIDA CR32-470

20018117

## Connection Diagram

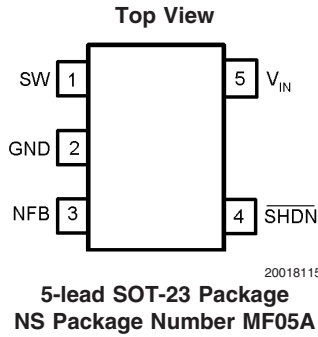

## Ordering Information

Order Number	Package Type	NSC Package Drawing	Supplied As	Package ID
LM2611AMF	SOT23-5	MF05A	1K Tape and Reel	S40A
LM2611AMFX			3K Tape and Reel	S40A
LM2611BMF			1K Tape and Reel	S40B
LM2611BMFX			3K Tape and Reel	S40B

## Pin Description

Pin	Name	Function
1	SW	Drain of internal switch. Connect at the node of the input inductor and C <sub>uk</sub> capacitor.
2	GND	Analog and power ground.
3	NFB	Negative feedback. Connect to output via external resistor divider to set output voltage.
4	SHDN	Shutdown control input. V <sub>IN</sub> = Device on. Ground = Device in shutdown.
5	V <sub>IN</sub>	Analog and power input. Filter out high frequency noise with a 0.1 μF ceramic capacitor placed close to the pin.

## Block Diagram

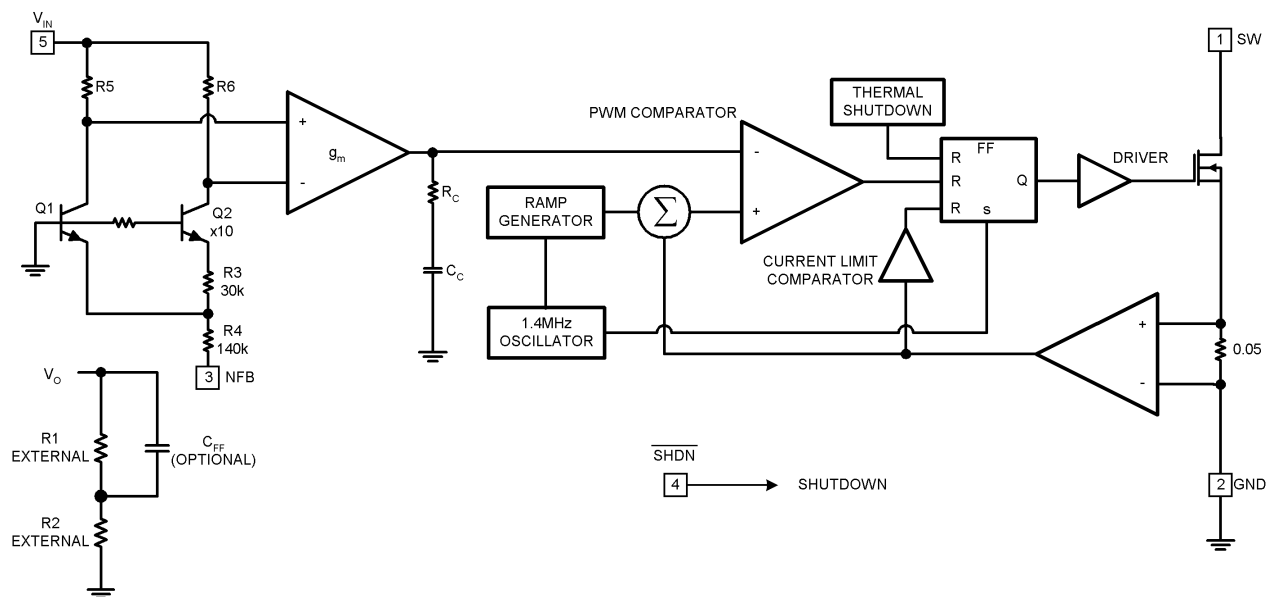

**Absolute Maximum Ratings** (Note 1)

If Military/Aerospace specified devices are required, please contact the National Semiconductor Sales Office/Distributors for availability and specifications.

$V_{IN}$	14.5V
SW Voltage	-0.4V to 36V
NFB Voltage	+0.4V to -6V
$\overline{SHDN}$ Voltage	-0.4V to 14.5V
Maximum Junction Temperature	125°C
Power Dissipation (Note 2)	Internally Limited
Lead Temperature	300°C

## ESD Susceptibility (Note 3)

Human Body Model	2kV
Machine Model	200V

**Operating Conditions**

Operating Junction Temperature Range	-40°C to +125°C
Storage Temperature	-65°C to +150°C
Supply Voltage	2.7V to 14V
$\theta_{JA}$	256°C/W

**Electrical Characteristics**

Specifications in standard type face are for  $T_J = 25^\circ\text{C}$  and those with **boldface type** apply over the Temperature Range  $T_J = -40^\circ\text{C}$  to  $+85^\circ\text{C}$ , unless otherwise specified.  $V_{IN} = 5.0\text{V}$  and  $I_L = 0\text{A}$ , unless otherwise specified.

Symbol	Parameter	Conditions	Min (Note 4)	Typ (Note 5)	Max (Note 4)	Units
$V_{IN}$	Input Voltage		<b>2.7</b>		<b>14</b>	V
$I_{SW}$	Switch Current Limit	Grade A	<b>1</b>	1.2	<b>2</b>	A
		Grade B	<b>0.7</b>	0.9		
$R_{DS(ON)}$	Switch ON Resistance	Grade A		0.5	0.65	$\Omega$
		Grade B		0.7	0.9	
$SHDN_{TH}$	Shutdown Threshold	Device enabled	<b>1.5</b>			V
		Device disabled			<b>0.50</b>	
$I_{SHDN}$	Shutdown Pin Bias Current	$V_{SHDN} = 0\text{V}$		0.0		$\mu\text{A}$
		$V_{SHDN} = 5\text{V}$		0.0	<b>1.0</b>	
NFB	Negative Feedback Reference	$V_{IN} = 3\text{V}$	<b>-1.205</b>	-1.23	<b>-1.255</b>	V
$I_{NFB}$	NFB Pin Bias Current	$V_{NFB} = -1.23\text{V}$	<b>-2.7</b>	-4.7	<b>-6.7</b>	$\mu\text{A}$
$I_q$	Quiescent Current	$V_{SHDN} = 5\text{V}$ , Switching		1.8	<b>3.5</b>	mA
		$V_{SHDN} = 5\text{V}$ , Not Switching		270	<b>500</b>	$\mu\text{A}$
		$V_{SHDN} = 0\text{V}$		0.024	<b>1</b>	$\mu\text{A}$
$\%V_{OUT}/\Delta V_{IN}$	Reference Line Regulation	$2.7\text{V} \leq V_{IN} \leq 14\text{V}$		0.02		$\%/V$
$f_s$	Switching Frequency		<b>1.0</b>	1.4	<b>1.8</b>	MHz
$D_{MAX}$	Maximum Duty Cycle		<b>82</b>	88		%
$I_L$	Switch Leakage	Not Switching			1	$\mu\text{A}$
		$V_{SW} = 5\text{V}$				

**Note 1:** Absolute maximum ratings are limits beyond which damage to the device may occur. Operating Ratings are conditions for which the device is intended to be functional, but device parameter specifications may not be guaranteed. For guaranteed specifications and test conditions, see the Electrical Characteristics.

**Note 2:** The maximum allowable power dissipation is a function of the maximum junction temperature,  $T_J(\text{MAX})$ , the junction-to-ambient thermal resistance,  $\theta_{JA}$ , and the ambient temperature,  $T_A$ . See the Electrical Characteristics table for the thermal resistance of various layouts. The maximum allowable power dissipation at any ambient temperature is calculated using:  $P_D(\text{MAX}) = (T_J(\text{MAX}) - T_A)/\theta_{JA}$ . Exceeding the maximum allowable power dissipation will cause excessive die temperature, and the regulator will go into thermal shutdown.

**Note 3:** The human body model is a 100 pF capacitor discharged through a 1.5k $\Omega$  resistor into each pin. The machine model is a 200pF capacitor discharged directly into each pin.

**Note 4:** All limits guaranteed at room temperature (standard typeface) and at temperature extremes (bold typeface). All room temperature limits are 100% tested or guaranteed through statistical analysis. All limits at temperature extremes are guaranteed via correlation using standard Statistical Quality Control (SQC) methods. All limits are used to calculate Average Outgoing Quality Level (AOQL).

**Note 5:** Typical numbers are at 25°C and represent the expected value of the parameter.

# Typical Performance Characteristics

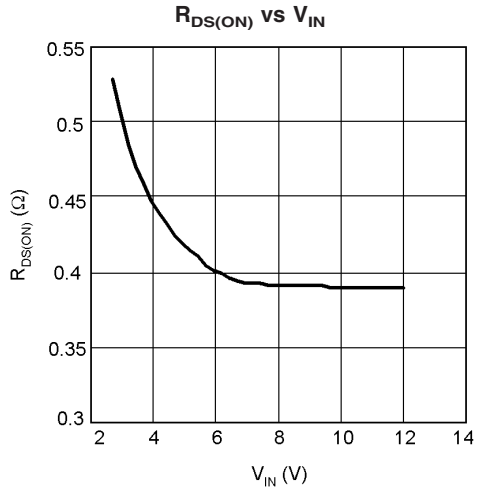

20018112

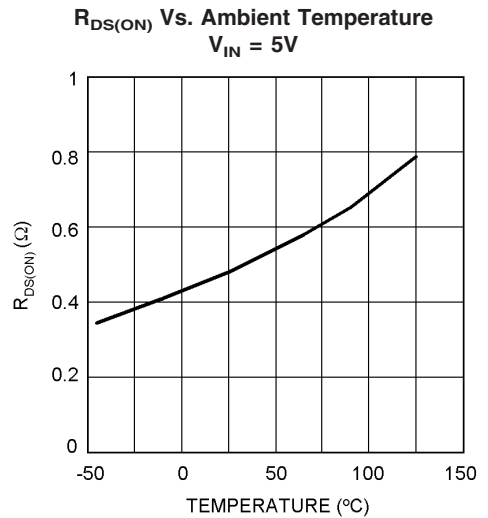

20018145

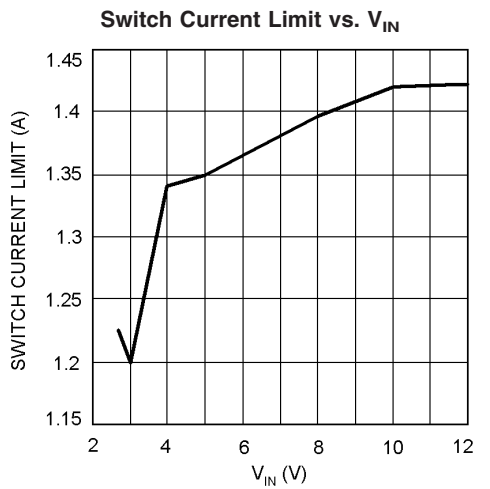

20018111

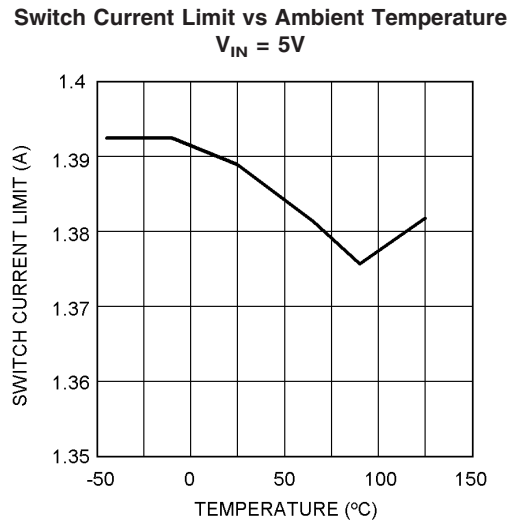

20018143

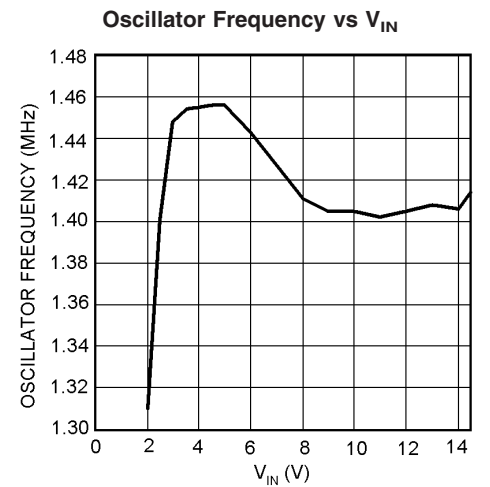

20018119

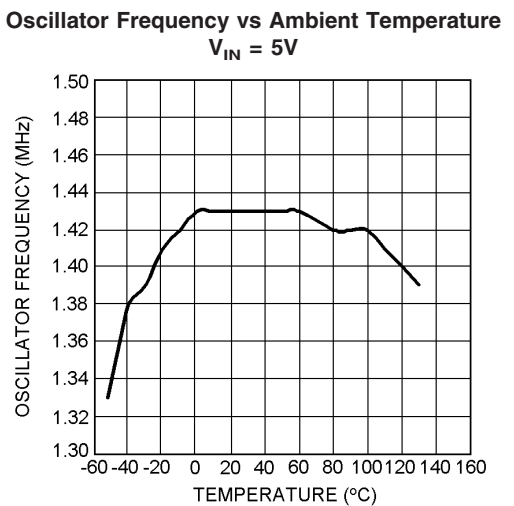

20018116

Typical Performance Characteristics (Continued)

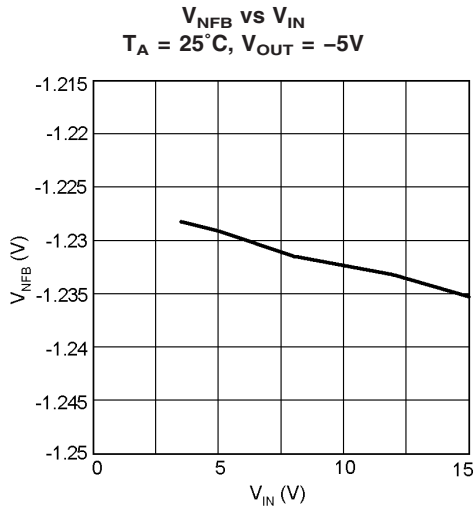

20018107

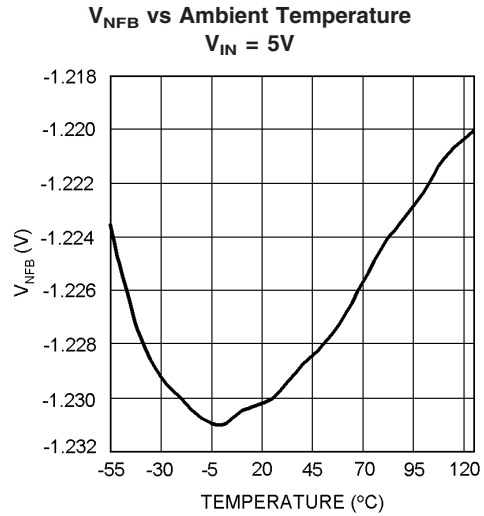

20018124

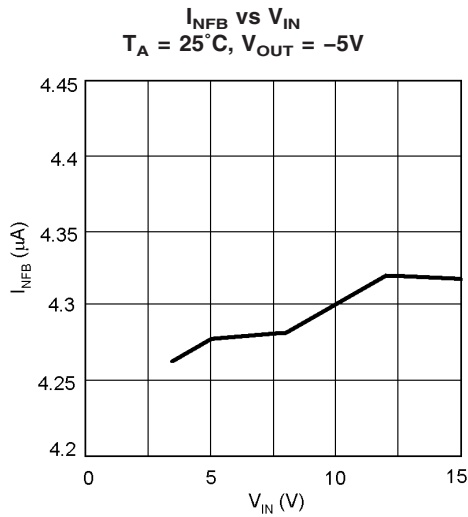

20018108

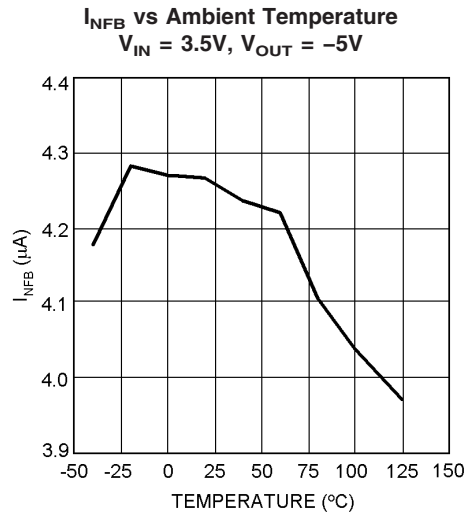

20018109

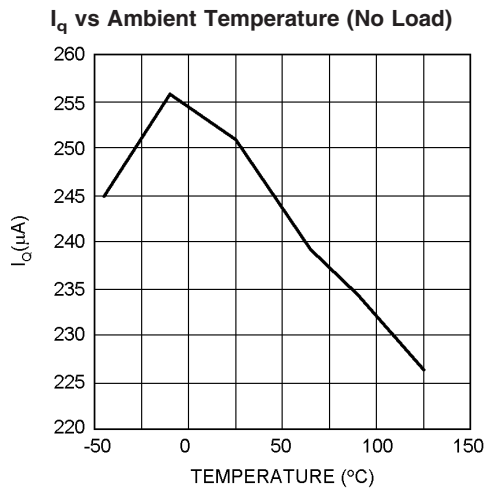

20018144

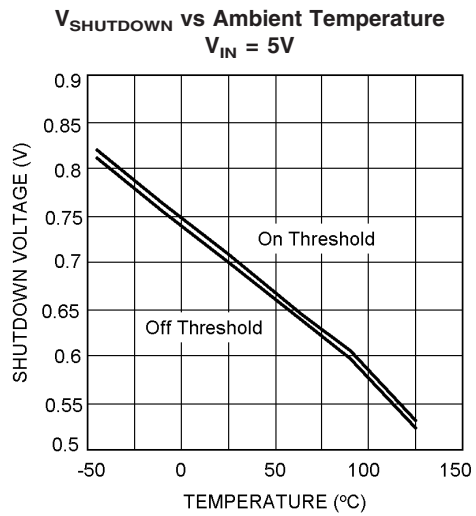

20018110

## Operation

### Cuk Converter

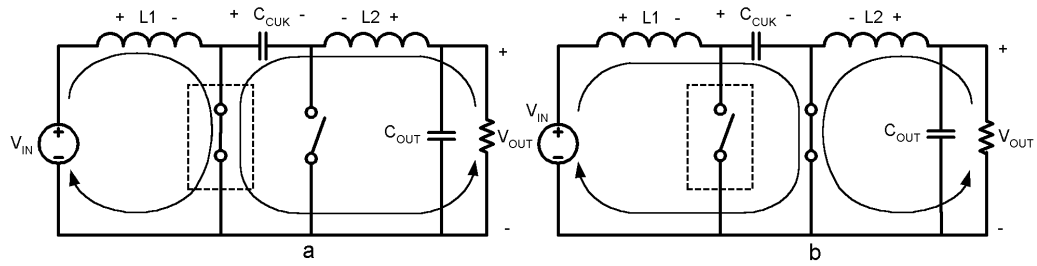

20018105

FIGURE 1. Operating Cycles of a Cuk Converter

The LM2611 is a current mode, fixed frequency PWM switching regulator with a  $-1.23\text{V}$  reference that makes it ideal for use in a Cuk converter. The Cuk converter inverts the input and can step up or step down the absolute value. Using inductors on both the input and output, the Cuk converter produces very little input and output current ripple. This is a significant advantage over other inverting topologies such as the buck-boost and flyback.

The operating states of the Cuk converter are shown in *Figure 1*. During the first cycle, the transistor switch is closed and the diode is open.  $L1$  is charged by the source and  $L2$  is charged by  $C_{\text{CUK}}$ , while the output current is provided by  $L2$ . In the second cycle,  $L1$  charges  $C_{\text{CUK}}$  and  $L2$  discharges through the load. By applying the volt-second balance to either of the inductors, the relationship of  $V_{\text{OUT}}$  to the duty cycle ( $D$ ) is found to be:

$$V_{\text{OUT}} = -V_{\text{IN}} \frac{D}{1-D}$$

The following sections review the steady-state design of the LM2611 Cuk converter.

#### Output and Input Inductor

*Figure 2* and *Figure 3* show the steady-state voltage and current waveforms for  $L1$  and  $L2$ , respectively. Referring to *Figure 1* (a), when the switch is closed,  $V_{\text{IN}}$  is applied across  $L1$ . In the next cycle, the switch opens and the diode becomes forward biased, and  $V_{\text{OUT}}$  is applied across  $L1$  (the voltage across  $C_{\text{CUK}}$  is  $V_{\text{IN}} - V_{\text{OUT}}$ ).

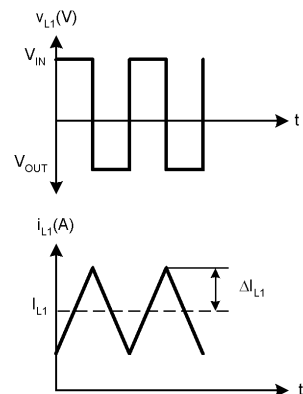

20018103

FIGURE 2. Voltage and Current Waveforms in Inductor  $L1$  of a Cuk Converter

The voltage and current waveforms of inductor  $L2$  are shown in *Figure 3*. During the first cycle of operation, when the switch is closed,  $V_{\text{IN}}$  is applied across  $L2$ . When the switch opens,  $V_{\text{OUT}}$  is applied across  $L2$ .

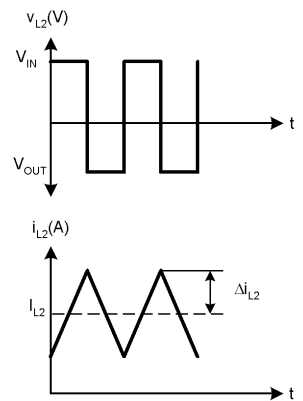

20018104

FIGURE 3. Voltage and Current Waveforms in Inductor  $L2$  of a Cuk Converter

## Operation (Continued)

The following equations define values given in *Figure 2* and *Figure 3*:

$$I_{L2} = I_{OUT}$$

$$\Delta i_{L2} = \frac{V_{IN} \times D \times T_S}{2 \times L_2}$$

$$I_{L1} = \frac{D}{1-D} I_{L2} = \frac{D}{1-D} I_{OUT}$$

$$\Delta i_{L1} = \frac{V_{IN} \times D \times T_S}{2 \times L_1}$$

Use these equations to choose correct core sizes for the inductors. The design of the LM2611's internal compensation assumes L1 and L2 are equal to 10 - 22  $\mu$ H, thus it is recommended to stay within this range.

### Switch Current Limit

The LM2611 incorporates a separate current limit comparator, making current limit independent of any other variables. The current limit comparator measures the switch current versus a reference that represents current limit. If at any time the switch current surpasses the current limit, the switch opens until the next switching period. To determine the maximum load for a given set of conditions, both the input and output inductor currents must be considered. The switch current is equal to  $i_{L1} + i_{L2}$ , and is drawn in *Figure 4*. In summary:

$$i_{SW(PEAK)} = i_{L1} + i_{L2} = I_{L1} + I_{L2} + \Delta i_{L1} + \Delta i_{L2}$$

$$= I_{OUT} \times \left(1 + \frac{D}{1-D}\right) + \frac{V_{IN} \times D \times T_S}{2} \times \left(\frac{1}{L_1} + \frac{1}{L_2}\right)$$

$i_{SW(PEAK)}$  must be less than the current limit (1.2A typical), but will also be limited by the thermal resistivity of the LM2611's SOT23-5 package ( $\theta_{JA} = 265^\circ\text{C/W}$ ).

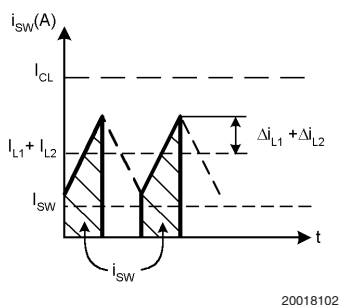

**FIGURE 4. Switch Current Waveform in a Cuk Converter. The peak value is equal to the sum of the average currents through L1 and L2 and the average-to-peak current ripples through L1 and L2.**

### Input Capacitor

The input current waveform to a Cuk converter is continuous and triangular, as shown in *Figure 2*. The input inductor insures that the input capacitor sees fairly low ripple currents. However, as the input inductor gets smaller, the input ripple goes up. The RMS current in the input capacitor is given by:

$$I_{CIN(RMS)} = \frac{1}{2\sqrt{3}} \frac{V_{IN}}{f_s L_1 \left(\frac{V_i}{|V_o|} + 1\right)}$$

The input capacitor should be capable of handling the RMS current. Although the input capacitor is not so critical in a Cuk converter, a 10 $\mu$ F or higher value good quality capacitor prevents any impedance interactions with the input supply. A 0.1 $\mu$ F or 1 $\mu$ F ceramic bypass capacitor is also recommended on the  $V_{IN}$  pin (pin 5) of the IC. This capacitor must be connected very close to pin 5 (within 0.2 inches).

### Output Capacitor

Like the input current, the output current is also continuous, triangular, and has low ripple (see  $i_{L2}$  in *Figure 3*). The output capacitor must be rated to handle its RMS current:

$$I_{COUT(RMS)} = \frac{\Delta i_{L2}}{\sqrt{3}} = \frac{1}{2\sqrt{3}} \frac{V_{IN}}{f_s L_2 \left(\frac{V_i}{|V_o|} + 1\right)}$$

For example,  $I_{COUT(RMS)}$  can range from 30mA to 180mA with  $10\mu\text{H} \leq L_{1,2} \leq 22\mu\text{H}$ ,  $-10\text{V} \leq V_{OUT} \leq -3.3\text{V}$ , and  $2.7\text{V} \leq V_{IN} \leq 30\text{V}$  ( $V_{IN}$  may be 30V if using separate power and analog supplies, see Split Supply Operation in the APPLICATIONS section). The worst case conditions are with  $L_{1,2}$ ,  $V_{OUT(MAX)}$ , and  $V_{IN(MAX)}$ . Many capacitor technologies will provide this level of RMS current, but ceramic capacitors are ideally suited for the LM2611. Ceramic capacitors provide a good combination of capacitance and equivalent series resistance (ESR) to keep the zero formed by the capacitance and ESR at high frequencies. The ESR zero is calculated as:

$$f_{ESR} = \frac{1}{2\pi C_{OUT} ESR} \text{ (Hz)}$$

A general rule of thumb is to keep  $f_{ESR} > 80\text{kHz}$  for LM2611 Cuk designs. Low ESR tantalum capacitors will usually be rated for at least 180mA in a voltage rating of 10V or above. However the ESR in a tantalum capacitor (even in a low ESR tantalum capacitor) is much higher than in a ceramic capacitor and could place  $f_{ESR}$  low enough to cause the LM2611 to run unstable.

### Improving Transient Response/Compensation

The compensator in the LM2611 is internal. However, a zero-pole pair can be added to the open loop frequency response by inserting a feed forward capacitor,  $C_{FF}$ , in parallel to the top feedback resistor ( $R_{FB1}$ ). Phase margin and bandwidth can be improved with the added zero-pole pair. This intum will improve the transient response to a step load change (see *Figure 5* and *Figure 6*). The position of the zero-pole pair is a function of the feedback resistors and the capacitor value:

## Operation (Continued)

$$\omega_z = \frac{1}{C_{FF}R_{FB1}} \text{ (rad/s)} \quad (1)$$

$$\omega_p = \frac{1}{C_{FF}R_{FB1}} \left(1 + \frac{R_{FB1}}{R_{FB2}}\right) \text{ (rad/s)} \quad (2)$$

The optimal position for this zero-pole pair will vary with circuit parameters such as  $D$ ,  $I_{OUT}$ ,  $C_{OUT}$ ,  $L1$ ,  $L2$ , and  $C_{CUK}$ . For most cases, the value for the zero frequency is between 5 kHz to 20 kHz. Notice how the pole position,  $\omega_p$ , is dependant on the feedback resistors  $R_{FB1}$  and  $R_{FB2}$ , and therefore also dependant on the output voltage. As the output voltage becomes closer to  $-1.26V$ , the pole moves towards the zero, tending to cancel it out. If the absolute magnitude of the output voltage is less than 3.3V, adding the zero-pole pair will not have much effect on the response.

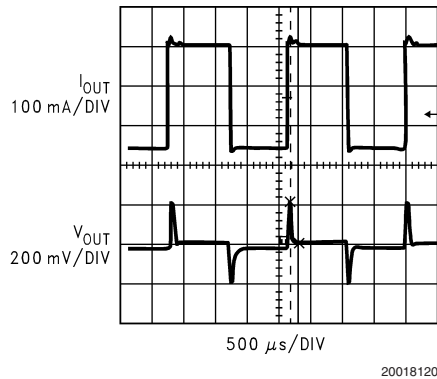

FIGURE 5. 130mA to 400mA Transient Response of the circuit in Figure 9 with  $C_{FF} = 1nF$

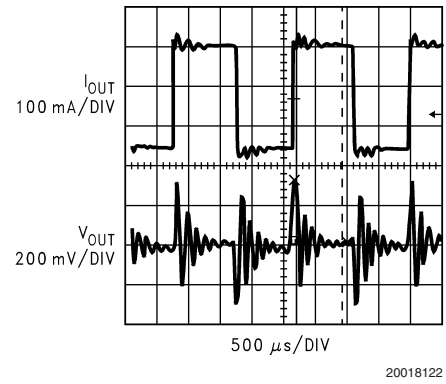

FIGURE 6. 130mA to 400mA Transient Response of the circuit in Figure 9 with  $C_{FF}$  disconnected

### Hysteretic Mode

As the output current decreases, there will come a point when the energy stored in the Cuk capacitor is more than the energy required by the load. The excess energy is absorbed by the output capacitor, causing the output voltage to increase out of regulation. The LM2611 detects when this happens and enters a pulse skipping, or hysteretic mode. In hysteretic mode, the output voltage ripple will increase, as illustrated in Figure 7 and Figure 8.

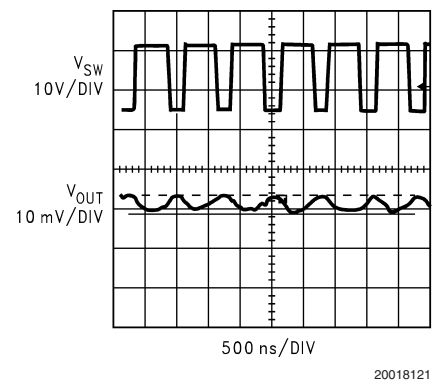
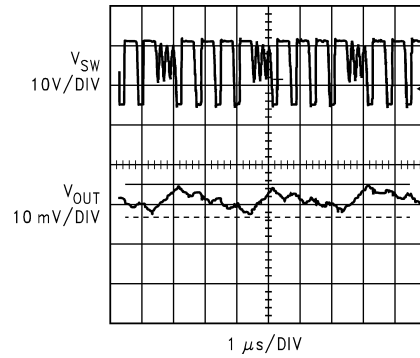

FIGURE 7. The LM2611 in PWM mode has very low ripple



## Operation (Continued)



20018123

**FIGURE 8. At low loads, the LM2611 enters a pulse-skipping mode. The output ripple slightly increases in this mode.**

### Thermal Shutdown

If the junction temperature of the LM2611 exceeds  $163^{\circ}\text{C}$ , it will enter thermal shutdown. In thermal shutdown, the part deactivates the driver and the switch turns off. The switch

remains off until the junction temperature drops to  $155^{\circ}\text{C}$ , at which point the part begins switching again. It will typically take 10ms for the junction temperature to drop from  $163^{\circ}\text{C}$  to  $155^{\circ}\text{C}$  with the switch off.

# Application Circuits

## 5V to -5V Inverting Converter

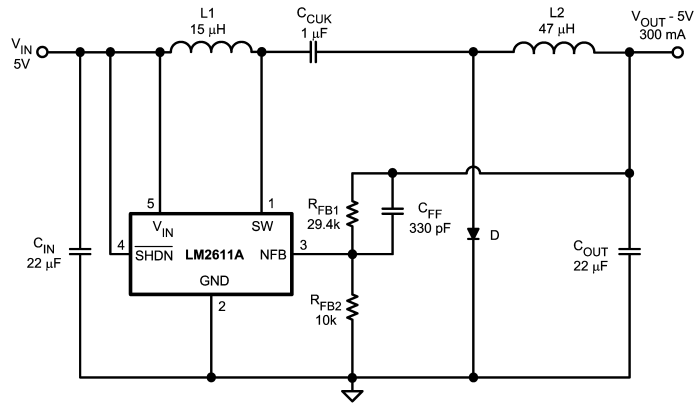

$C_{IN}$ : TAIYO YUDEN X5R JMK325BJ226MM  
 $C_{CUK}$ : TAIYO YUDEN X5R EMK316BJ105MF  
 $C_{OUT}$ : TAIYO YUDEN X5R JMK325BJ226MM  
 D: ON SEMICONDUCTOR MBR0520  
 L1: SUMIDA CR32-150  
 L2: SUMIDA CR32-470

20018117

### Efficiency vs Load Current

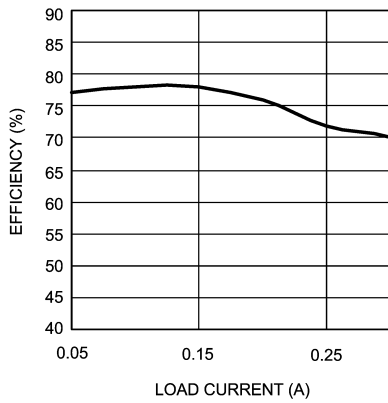

20018158

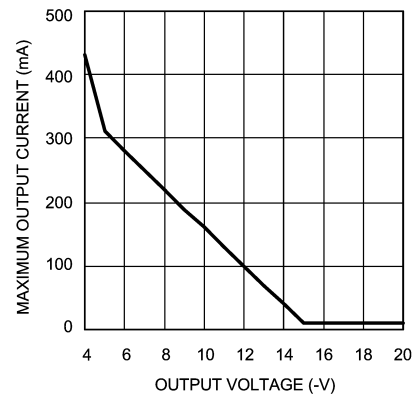

20018160

**FIGURE 9. The Maximum Output Current vs Output Voltage (Adjust  $R_{FB2}$  to Set a Different Output Voltage) When The Input Voltage is 5V**

Application Circuits (Continued)

9V to -5V Inverting Converter

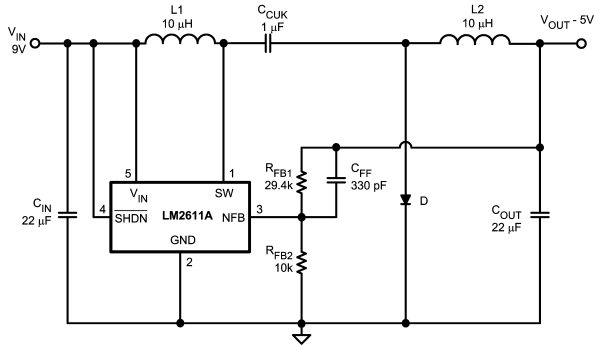

C<sub>IN</sub>: TAIYO YUDEN X5R JMK325BJ226MM  
 C<sub>CUK</sub>: TAIYO YUDEN X5R EMK316BJ105MF  
 C<sub>OUT</sub>: TAIYO YUDEN X5R JMK325BJ226MM  
 D: ON SEMICONDUCTOR MBR0520  
 L1: SUMIDA CR32-100  
 L2: SUMIDA CR32-100

20018164

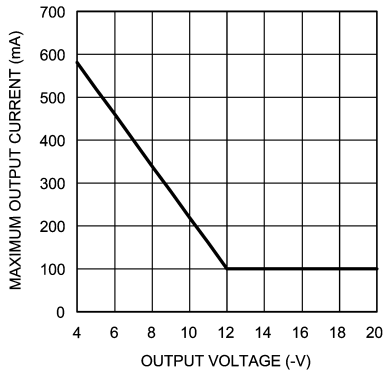

20018161

FIGURE 10. The Maximum Output Current vs Output Voltage (Adjust R<sub>FB2</sub> to Set a Different Output Voltage) When The Input Voltage is 9V

12V to -5V Inverting Converter

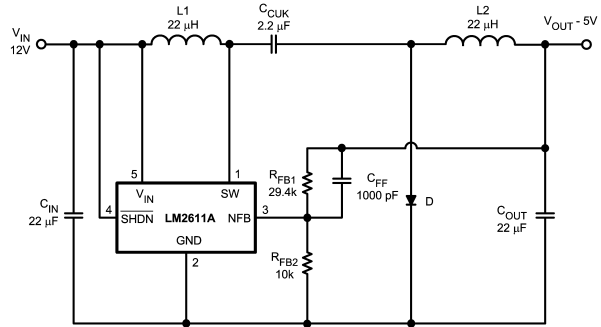

C<sub>IN</sub>: TAIYO YUDEN X5R JMK325BJ226MM  
 C<sub>CUK</sub>: TAIYO YUDEN X5R EMK316BJ225ML  
 C<sub>OUT</sub>: TAIYO YUDEN X5R JMK325BJ226MM  
 D: ON SEMICONDUCTOR MBR0520  
 L1: SUMIDA CR32-220  
 L2: SUMIDA CR32-220

20018163

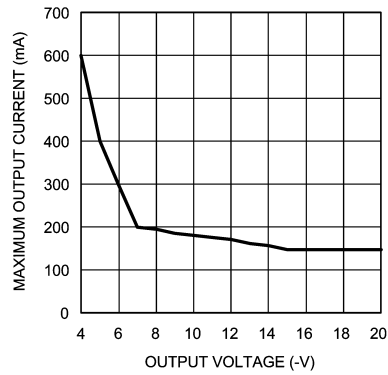

20018162

FIGURE 11. The Maximum Output Current vs Output Voltage (Adjust R<sub>FB2</sub> to Set a Different Output Voltage) When The Input Voltage is 12V

## Application Circuits (Continued)

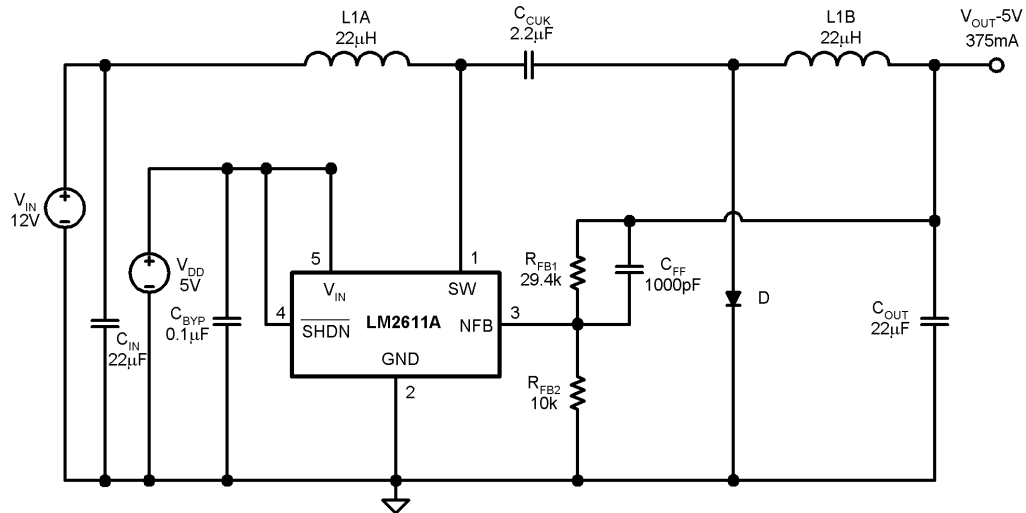

$C_{IN}$ : VISHAY/SPRAGUE 595D226X0020C2T  
 $C_{CUK}$ : TAIYO YUDEN X5R EMK316BJ225ML  
 $C_{OUT}$ : TAIYO YUDEN X5R JMK325BJ226MM  
 D: ON SEMICONDUCTOR MBR0520  
 L1: SUMIDA CR32-220

20018114

FIGURE 12. LM2611 Operating with Separate Power and Biasing Supplies

**Split Supply Operation**

The LM2611 may be operated with separate power and bias supplies. In the circuit shown in *Figure 12*,  $V_{IN}$  is the power supply that the regulated voltage is derived from, and  $V_{DD}$  is a low current supply used to bias the LM2611. Conditions for the supplies are:

$$2.7V \leq V_{DD} \leq 14V$$

$$0V \leq V_{IN} \leq (36 - |V_{OUT}|) V$$

As the input voltage increases, the maximum output current capability increases. Using a separate, higher voltage supply for power conversion enables the LM2611 to provide higher output currents than it would with a single supply that is limited in voltage by  $V_{IN(MAX)}$ .

**Shutdown/Soft Start**

A soft start circuit is used in switching power supplies to limit the input inrush current upon start-up. Without a soft-start circuit, the inrush current can be several times the steady-state load current, and thus apply unnecessary stress to the input source. The LM2611 does not have soft-start circuitry, but implementing the circuit in *Figure 13* will lower the peak inrush current. The  $\overline{SHDN}$  pin is coupled to the output through  $C_{SS}$ . The LM2611 is toggled between shutdown and run states while the output slowly decreases to its steady-state value. The energy required to reach steady-state is spread over a longer time and the input current spikes decrease (see *Figure 14* and *Figure 15*).

Application Circuits (Continued)

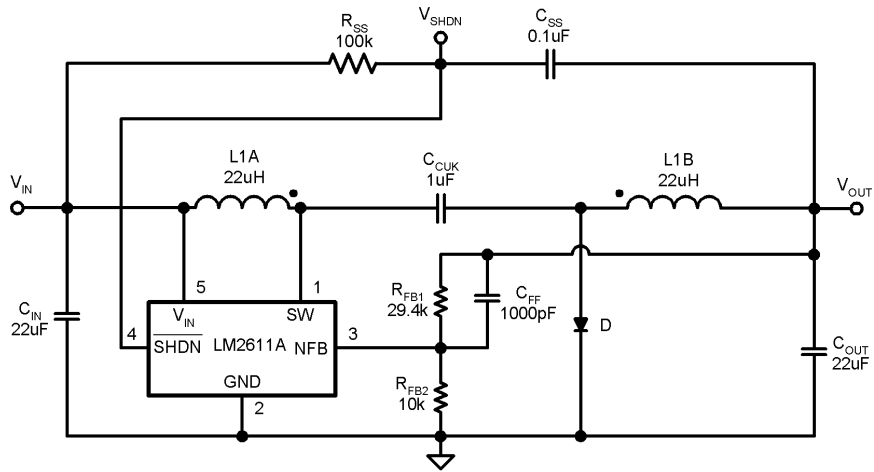

20018125

FIGURE 13. LM2611 Soft Start Circuit

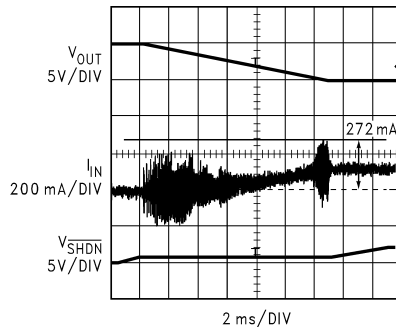

20018142

FIGURE 14. Start-Up Waveforms with Soft Start Circuit

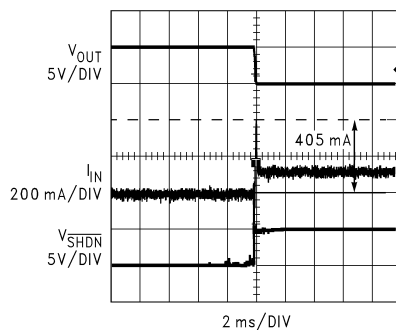

20018141

FIGURE 15. Start-Up Waveforms without Soft Start Circuit

## Application Circuits (Continued)

### High Duty Cycle/Load Current Operation

The circuit in *Figure 16* is used for high duty cycles ( $D > 0.5$ ) and high load currents. The duty cycle will begin to increase beyond 50% as the input voltage drops below the absolute

magnitude of the output voltage.  $R_{FB3}$  and  $C_{FF2}$  are added to the feedback network to introduce a low frequency lag compensation (pole-zero pair) necessary to stabilize the circuit under the combination of high duty cycle and high load currents.

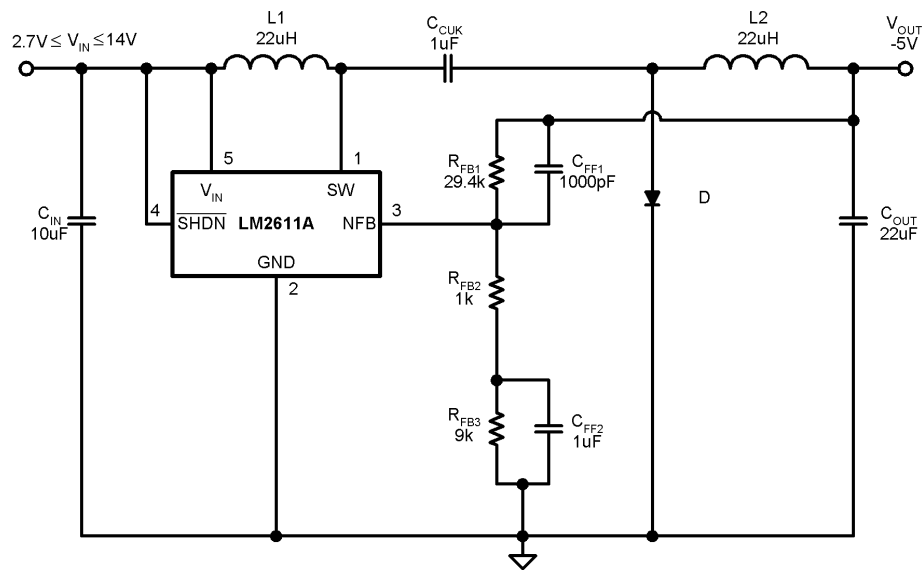

$C_{IN}$ : TAIYO YUDEN X5R JMK325BJ106MN  
 $C_{CUK}$ : TAIYO YUDEN X5R TMK316BJ105ML  
 $C_{OUT}$ : TAIYO YUDEN X5R JMK325BJ226MM  
 D: ON SEMICONDUCTOR MBR0520  
 L1, L2: SUMIDA CDRH6D28-220

20018129

FIGURE 16. LM2611 High Current Schematic

## Physical Dimensions inches (millimeters)

unless otherwise noted

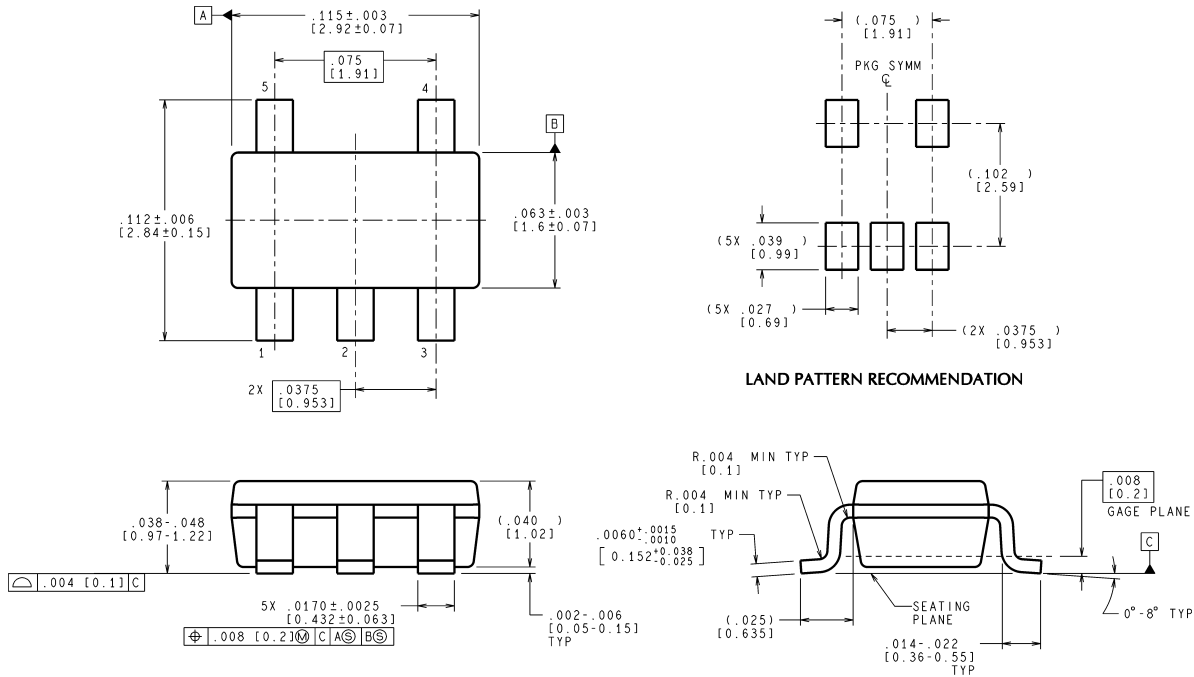

CONTROLLING DIMENSION IS INCH  
VALUES IN [ ] ARE MILLIMETERS

**5-lead SOT-23 Package**  
**NS Package Number MF05A**

MF05A (Rev B)

National does not assume any responsibility for use of any circuitry described, no circuit patent licenses are implied and National reserves the right at any time without notice to change said circuitry and specifications.

For the most current product information visit us at [www.national.com](http://www.national.com).

### LIFE SUPPORT POLICY

NATIONAL'S PRODUCTS ARE NOT AUTHORIZED FOR USE AS CRITICAL COMPONENTS IN LIFE SUPPORT DEVICES OR SYSTEMS WITHOUT THE EXPRESS WRITTEN APPROVAL OF THE PRESIDENT AND GENERAL COUNSEL OF NATIONAL SEMICONDUCTOR CORPORATION. As used herein:

1. Life support devices or systems are devices or systems which, (a) are intended for surgical implant into the body, or (b) support or sustain life, and whose failure to perform when properly used in accordance with instructions for use provided in the labeling, can be reasonably expected to result in a significant injury to the user.
2. A critical component is any component of a life support device or system whose failure to perform can be reasonably expected to cause the failure of the life support device or system, or to affect its safety or effectiveness.

### BANNED SUBSTANCE COMPLIANCE

National Semiconductor certifies that the products and packing materials meet the provisions of the Customer Products Stewardship Specification (CSP-9-111C2) and the Banned Substances and Materials of Interest Specification (CSP-9-111S2) and contain no "Banned Substances" as defined in CSP-9-111S2.



**National Semiconductor**  
**Americas Customer Support Center**  
Email: [new.feedback@nsc.com](mailto:new.feedback@nsc.com)  
Tel: 1-800-272-9959

**National Semiconductor**  
**Europe Customer Support Center**  
Fax: +49 (0) 180-530 85 86  
Email: [europe.support@nsc.com](mailto:europe.support@nsc.com)  
Deutsch Tel: +49 (0) 69 9508 6208  
English Tel: +44 (0) 870 24 0 2171  
Français Tel: +33 (0) 1 41 91 8790

**National Semiconductor**  
**Asia Pacific Customer Support Center**  
Email: [ap.support@nsc.com](mailto:ap.support@nsc.com)

**National Semiconductor**  
**Japan Customer Support Center**  
Fax: 81-3-5639-7507  
Email: [jpn.feedback@nsc.com](mailto:jpn.feedback@nsc.com)  
Tel: 81-3-5639-7560

[www.national.com](http://www.national.com)