

TOSHIBA PHOTOCOUPLER GaAs IRED & PHOTO-TRANSISTOR

TLP627, TLP627-2, TLP627-4

PROGRAMMABLE CONTROLLERS.
DC - OUTPUT MODULE.
TELECOMMUNICATION.

The TOSHIBA TLP627, -2, and -4 consist of a gallium arsenide infreared emitting diode optically coupled to a darlington connected phototransistor which has an integral base-emitter resistor to optimize switching speed and elevated temperature characteristics.

The TLP627-2 offers two isolated channels in a eight lead plastic DIP, while the TLP627-4 provide four isolated channels per package.

- Collector-Emitter Voltage : 300V (Min.)
- Current Transfer Ratio : 1000% (Min.)
- Isolation Voltage : 5000Vrms (Min.)
- UL Recognized : UL1577, File No. E67349

	MADE IN JAPAN		MADE IN THAILAND	
UL Recognized	E67349	*1	E152349	*1
BSI Approved	7426, 7427	*2	7426, 7427	*2

*1 UL1577

*2 BS EN60065 : 1994, BS EN60950 : 1992

PIN CONFIGURATIONS (TOP VIEW)

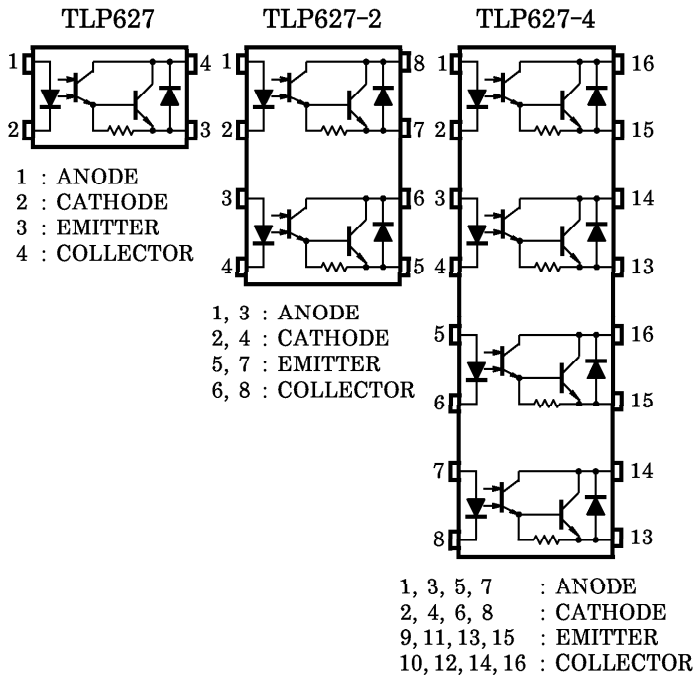

Unit in mm

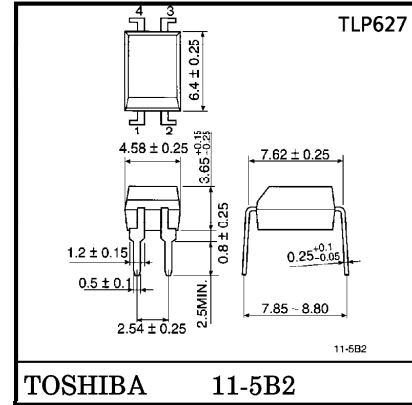

Weight : 0.26g

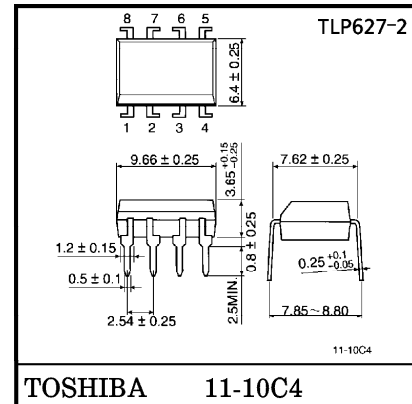

Weight : 0.54g

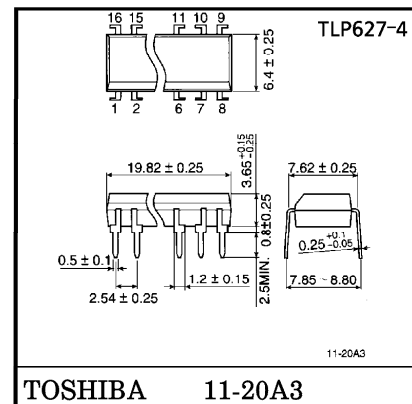

Weight : 1.1g

961001EBC2

● TOSHIBA is continually working to improve the quality and the reliability of its products. Nevertheless, semiconductor devices in general can malfunction or fail due to their inherent electrical sensitivity and vulnerability to physical stress. It is the responsibility of the buyer, when utilizing TOSHIBA products, to observe standards of safety, and to avoid situations in which a malfunction or failure of a TOSHIBA product could cause loss of human life, bodily injury or damage to property. In developing your designs, please ensure that TOSHIBA products are used within specified operating ranges as set forth in the most recent products specifications. Also, please keep in mind the precautions and conditions set forth in the TOSHIBA Semiconductor Reliability Handbook.

MAXIMUM RATINGS (Ta = 25°C)

CHARACTERISTIC		SYMBOL	RATING		UNIT
			TLP627	TLP627-2 TLP627-4	
LED	Forward Current	I _F	60	50	mA
	Forward Current Derating	ΔI _F /°C	-0.7 (Ta ≥ 39°C)	-0.5 (Ta ≥ 25°C)	mA/°C
	Pulse Forward Current	I _{FP}	1 (100μs pulse, 100pps)		A
	Power Dissipation (1 Circuit)	P _D	100	70	mW
	Power Dissipation Derating (Ta ≥ 25°C, 1 Circuit)	ΔP _D /°C	-1.0	-0.7	mW/°C
	Reverse Voltage	V _R	5		V
	Junction Temperature	T _j	125		°C
DETECTOR	Collector-Emitter Voltage	V _{CEO}	300		V
	Emitter-Collector Voltage	V _{ECO}	0.3		V
	Collector Current	I _C	150		mA
	Collector Power Dissipation (1 Circuit)	P _C	150 (*300)	100	mW
	Collector Power Dissipation Derating (Ta ≥ 25°C, 1 Circuit)	ΔP _C /°C	-1.5 (*-3.5)	-1.0	mW/°C
	Junction Temperature	T _j	125		°C
Storage Temperature Range		T _{stg}	-55~125		°C
Operating Temperature Range		T _{opr}	-55~100		°C
Lead Soldering Temperature		T _{sold}	260 (10sec)		°C
Total Package Power Dissipation (1 Circuit)		P _T	250 (*320)	150	mW
Total Package Power Dissipation Derating (Ta ≥ 25°C, 1 Circuit)		ΔP _T /°C	-2.5 (*-3.2)	-1.5	mW/°C
Isolation Voltage		BV _S	5000 (AC, 1min., R.H. ≤ 60%)		V _{rms}

* I_F = 20mA Max

RECOMMENDED OPERATING CONDITIONS

CHARACTERISTIC	SYMBOL	MIN.	TYP.	MAX.	UNIT
Supply Voltage	V _{CC}	—	—	200	V
Forward Current	I _F	—	16	25	mA
Collector Current	I _C	—	—	120	mA
Operating Temperature	T _{opr}	-25	—	85	°C

961001EBC2'

- Gallium arsenide (GaAs) is a substance used in the products described in this document. GaAs dust and fumes are toxic. Do not break, cut or pulverize the product, or use chemicals to dissolve them. When disposing of the products, follow the appropriate regulations. Do not dispose of the products with other industrial waste or with domestic garbage.
- The products described in this document are subject to foreign exchange and foreign trade control laws.
- The information contained herein is presented only as a guide for the applications of our products. No responsibility is assumed by TOSHIBA CORPORATION for any infringements of intellectual property or other rights of the third parties which may result from its use. No license is granted by implication or otherwise under any intellectual property or other rights of TOSHIBA CORPORATION or others.
- The information contained herein is subject to change without notice.

INDIVIDUAL ELECTRICAL CHARACTERISTICS (Ta = 25°C)

CHARACTERISTIC		SYMBOL	TEST CONDITION	MIN.	TYP.	MAX.	UNIT
LED	Forward Voltage	V_F	$I_F = 10\text{mA}$	1.0	1.15	1.3	V
	Reverse Current	I_R	$V_R = 5\text{V}$	—	—	10	μA
	Capacitance	C_T	$V = 0, f = 1\text{MHz}$	—	30	—	pF
DETECTOR	Collector-Emitter Breakdown Voltage	$V(\text{BR})_{\text{CEO}}$	$I_C = 0.1\text{mA}$	300	—	—	V
	Emitter-Collector Breakdown Voltage	$V(\text{BR})_{\text{ECO}}$	$I_E = 0.1\text{mA}$	0.3	—	—	V
	Collector Dark Current	I_{CEO}	$V_{\text{CE}} = 200\text{V}$	—	10	200	nA
			$V_{\text{CE}} = 200\text{V}, T_a = 85^\circ\text{C}$	—	—	20	μA
Capacitance Collector to Emitter	C_{CE}	$V = 0, f = 1\text{MHz}$	—	10	—	pF	

COUPLED ELECTRICAL CHARACTERISTICS (Ta = 25°C)

CHARACTERISTIC	SYMBOL	TEST CONDITION	MIN.	TYP.	MAX.	UNIT
Current Transfer Ratio	I_C / I_F	$I_F = 1\text{mA}, V_{\text{CE}} = 1\text{V}$	1000	4000	—	%
Saturated CTR	$I_C / I_F(\text{sat})$	$I_F = 10\text{mA}, V_{\text{CE}} = 1\text{V}$	500	—	—	%
Collector-Emitter Saturation Voltage	$V_{\text{CE}}(\text{sat})$	$I_C = 10\text{mA}, I_F = 1\text{mA}$	—	—	1.0	V
		$I_C = 100\text{mA}, I_F = 10\text{mA}$	0.3	—	1.2	

ISOLATION CHARACTERISTICS (Ta = 25°C)

CHARACTERISTIC	SYMBOL	TEST CONDITION	MIN.	TYP.	MAX.	UNIT
Capacitance Input to Output	C_S	$V_S = 0, f = 1\text{MHz}$	—	0.8	—	pF
Isolation Resistance	R_S	$V_S = 500\text{V R.H.} \leq 60\%$	5×10^{10}	10^{14}	—	Ω
Isolation Voltage	BV_S	AC, 1 minute	5000	—	—	Vrms
		AC, 1 second, in oil	—	10000	—	Vdc
		DC, 1 minute, in oil	—	10000	—	

SWITCHING CHARACTERISTICS (Ta = 25°C)

CHARACTERISTIC	SYMBOL	TEST CONDITION	MIN.	TYP.	MAX.	UNIT
Rise Time	t_r	$V_{CC} = 10V$ $I_C = 10mA$ $R_L = 100\Omega$	—	40	—	μs
Fall Time	t_f		—	15	—	
Turn-on Time	t_{on}		—	50	—	
Turn-off Time	t_{off}		—	15	—	
Turn-on Time	t_{ON}	$R_L = 180\Omega$ (Fig.1) $V_{CC} = 10V, I_F = 16mA$	—	5	—	μs
Storage Time	t_s		—	40	—	
Turn-off Time	t_{OFF}		—	80	—	

Fig.1 SWITCHING TIME TEST CIRCUIT

