

FEATURES

- *Guaranteed* 10ppm/°C Temperature Coefficient
- *Guaranteed* 1Ω Maximum Dynamic Impedance
- *Guaranteed* 20μV Maximum Wideband Noise
- Wide Operating Current Range 0.6mA to 15mA

APPLICATIONS

- Transducers
- A/D and D/A Converters
- Calibration Standards
- Instrumentation Reference

DESCRIPTION

The LM129 temperature compensated 6.9V zener references provide excellent stability over time and temperature, very low dynamic impedance and a wide operating current range. The device achieves low dynamic impedance by incorporating a high gain shunt regulator around the zener. The excellent noise performance of the device is achieved by using a “buried zener” design which eliminates surface noise phenomenon associated with ordinary zeners. To serve a wide variety of applications, the LM129 is available in several temperature coefficient grades and two package styles. A 20mA positive current source application is shown below.

LT, LTC and LT are registered trademarks of Linear Technology Corporation.

TYPICAL APPLICATION

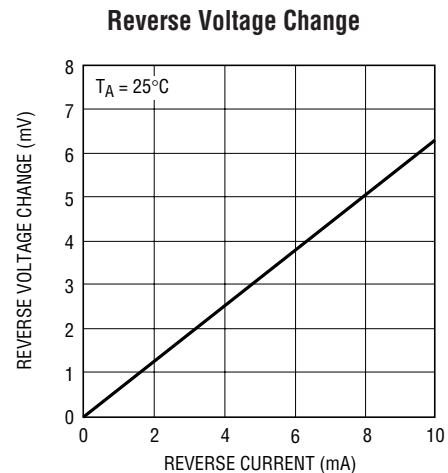
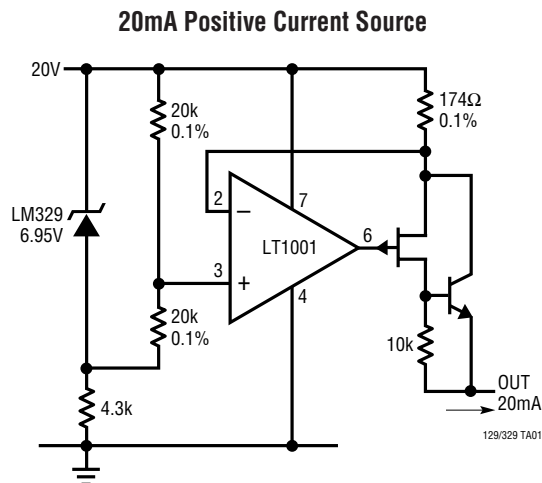

LM129/LM329

ABSOLUTE MAXIMUM RATINGS (Note 1)

Operating Temperature Range	Lead Temperature (Soldering, 10 sec)..... 300°C
LM129 (OBSOLETE) -55°C to 125°C	Reverse Breakdown Current 30mA
LM329 0°C to 70°C	Forward Current 2mA
Storage Temperature Range -65°C to 150°C	

PACKAGE/ORDER INFORMATION

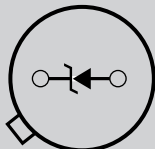
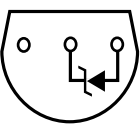
BOTTOM VIEW	ORDER PART NUMBER	BOTTOM VIEW	ORDER PART NUMBER
 <p>H PACKAGE 2-LEAD TO-46 METAL CAN T_{JMAX} = 150°C, θ_{JA} = 440°C/W, θ_{JC} = 80°C/W</p> <p>OBSOLETE PACKAGE Consider the Z Package for Alternate Source</p>	LM129AH	 <p>Z PACKAGE 3-LEAD PLASTIC TO-92 T_{JMAX} = 150°C, θ_{JA} = 160°C/W</p>	LM329AH
	LM129BH		LM329BH
	LM129CH		LM329CH
			LM329DH

Consult LTC Marketing for availability of LM329AZ, LM329CZ and LM329DZ

ELECTRICAL CHARACTERISTICS

The ● denotes the specifications which apply over the full operating temperature range, otherwise specifications are at T_A = 25°C. (Note 2)

SYMBOL	PARAMETER	CONDITIONS	LM129A/ LM129B/LM129C			LM329A/LM329B/ LM329C/LM329D			UNITS
			MIN	TYP	MAX	MIN	TYP	MAX	
V _Z	Reverse Breakdown Voltage	T _A = 25°C, 0.6mA ≤ I _R ≤ 15mA	6.7	6.9	7.2	6.6	6.9	7.25	V
$\frac{\Delta V_Z}{\Delta I_R}$	Reverse Breakdown Voltage Change with Current	T _A = 25°C, 0.6mA ≤ I _R ≤ 15mA 1mA ≤ I _R ≤ 15mA		9 12	14		9 12	20	mV mV
$\frac{\Delta V_Z}{\Delta \text{Temp}}$	Temperature Coefficient	I _R = 1mA, LM129A/LM329A LM129A/LM329B LM129A/LM329C LM329D		6 15 30	10 20 50		6 15 30 50	10 20 50 100	ppm/°C ppm/°C ppm/°C ppm/°C
	Change in Temperature Coefficient	1mA ≤ I _R ≤ 15mA		1			1		ppm/°C
r _Z	Dynamic Impedance	T _A = 25°C, I _R = 1mA 1mA ≤ I _R ≤ 15mA		0.6 0.8	1		0.8 1	2	Ω Ω
e _n	RMS Noise	T _A = 25°C, 10Hz ≤ f ≤ 10kHz		7	20		7	100	μV
$\frac{\Delta V_Z}{\Delta \text{Time}}$	Long Term Stability	T _A = 45°C ± 0.1°C, I _R = 1mA ± 0.3%		20			20		ppm/kHr

Note 1: Absolute Maximum Ratings are those values beyond which the life of a device may be impaired.

Note 2: To determine the junction temperature as a function of the ambient temperature, see θ_{JA} for each package.

TYPICAL PERFORMANCE CHARACTERISTICS

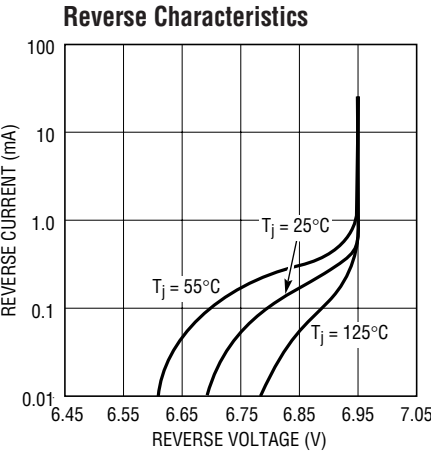

129/329 G01

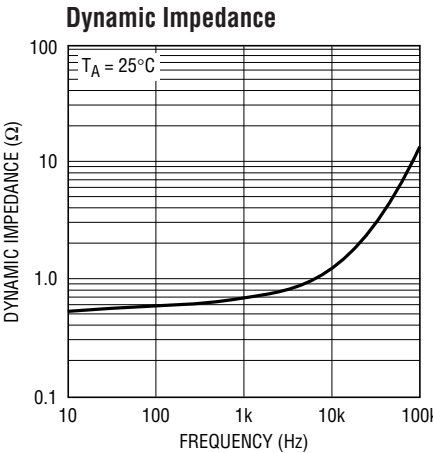

129/329 G02

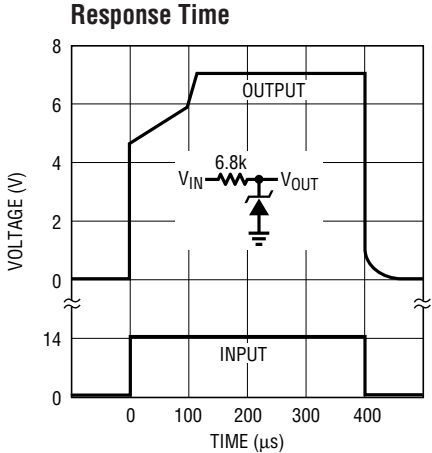

129/329 G03

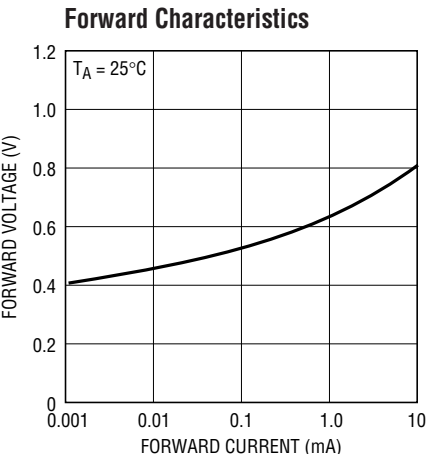

129/329 G04

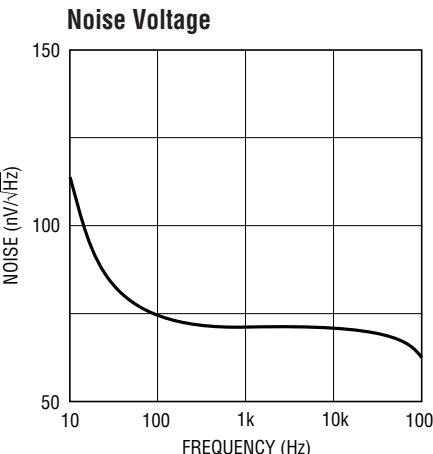

129/329 G05

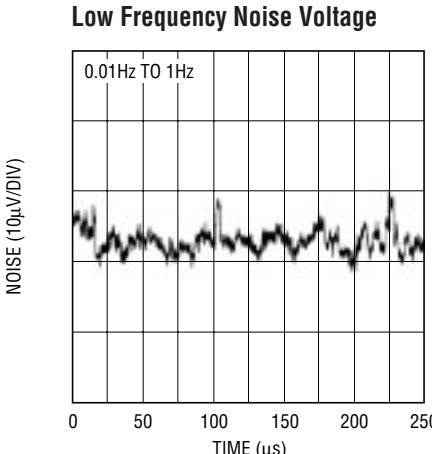

129/329 G06

SCHEMATIC DIAGRAM

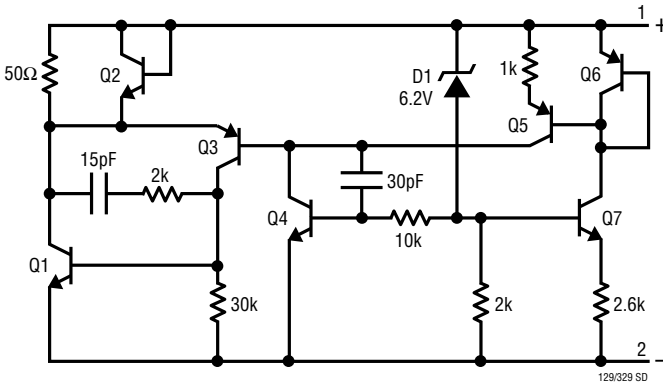

129/329 SD

TYPICAL APPLICATIONS

Common Reference

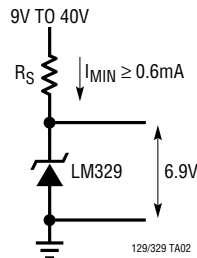

Buffered Reference Using a Single Supply

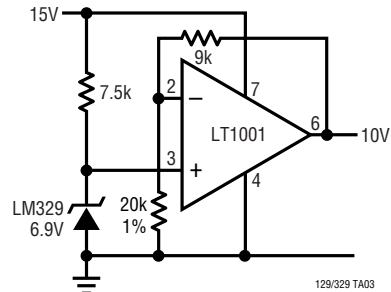

PACKAGE DESCRIPTION

H Package 2-Lead and 3-Lead TO-46 Metal Can (Reference LTC DWG # 05-08-1340)

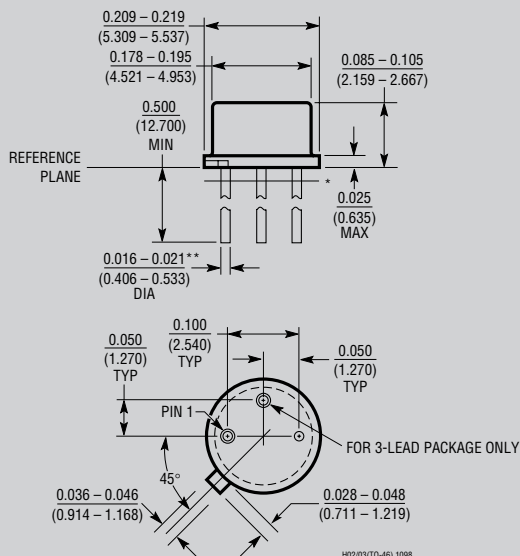

* LEAD DIAMETER IS UNCONTROLLED BETWEEN THE REFERENCE PLANE AND 0.045" BELOW THE REFERENCE PLANE

** FOR SOLDER DIP LEAD FINISH, LEAD DIAMETER IS 0.016 - 0.024 (0.406 - 0.610)

OBSOLETE PACKAGE

Z Package 3-Lead Plastic TO-92 (Similar to TO-226) (Reference LTC DWG # 05-08-1410)

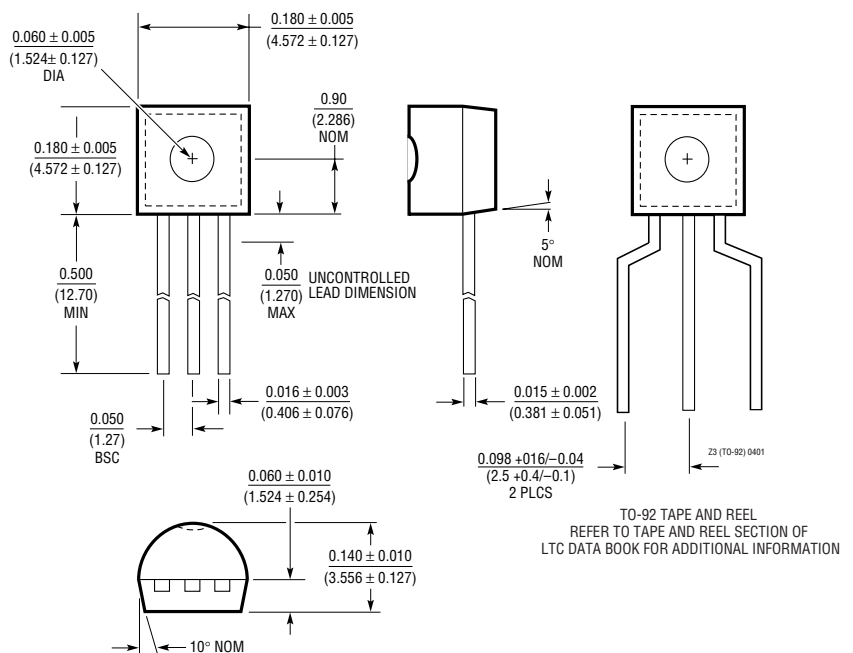

TO-92 TAPE AND REEL
REFER TO TAPE AND REEL SECTION OF
LTC DATA BOOK FOR ADDITIONAL INFORMATION

RELATED PARTS

PART NUMBER	DESCRIPTION	COMMENTS
LT1460	Micropower, Precise Series Reference	10ppm/°C, Output Voltages: 2.5V, 3V, 3.3V, 5V, 10V
LT1634	0.05% Accurate, 10ppm/°C, Shunt Reference	Output Voltages: 1.25V, 2.5V, 4.096V, 5V