

PRELIMINARY DATASHEET

DATASHEET

PRODUCT : 64M (x16) Flash Memory

MODEL No : **LH28F640BFHE-PBTL90**

-
- This device datasheet is subject to change without notice.
 - Copyright Sharp Co., Ltd. All rights reserved. No reproduction or republication without written permission.
 - Contact your local Sharp sales office to obtain the latest datasheet.
-

Refer to SHARP's Website (www.sharp.co.jp) for the latest information.

- Handle this document carefully for it contains material protected by international copyright law. Any reproduction, full or in part, of this material is prohibited without the express written permission of the company.
- When using the products covered herein, please observe the conditions written herein and the precautions outlined in the following paragraphs. In no event shall the company be liable for any damages resulting from failure to strictly adhere to these conditions and precautions.
 - (1) The products covered herein are designed and manufactured for the following application areas. When using the products covered herein for the equipment listed in Paragraph (2), even for the following application areas, be sure to observe the precautions given in Paragraph (2). Never use the products for the equipment listed in Paragraph (3).
 - Office electronics
 - Instrumentation and measuring equipment
 - Machine tools
 - Audiovisual equipment
 - Home appliance
 - Communication equipment other than for trunk lines
 - (2) Those contemplating using the products covered herein for the following equipment which demands high reliability, should first contact a sales representative of the company and then accept responsibility for incorporating into the design fail-safe operation, redundancy, and other appropriate measures for ensuring reliability and safety of the equipment and the overall system.
 - Control and safety devices for airplanes, trains, automobiles, and other transportation equipment
 - Mainframe computers
 - Traffic control systems
 - Gas leak detectors and automatic cutoff devices
 - Rescue and security equipment
 - Other safety devices and safety equipment, etc.
 - (3) Do not use the products covered herein for the following equipment which demands extremely high performance in terms of functionality, reliability, or accuracy.
 - Aerospace equipment
 - Communications equipment for trunk lines
 - Control equipment for the nuclear power industry
 - Medical equipment related to life support, etc.
 - (4) Please direct all queries and comments regarding the interpretation of the above three Paragraphs to a sales representative of the company.
- Please direct all queries regarding the products covered herein to a sales representative of the company.

CONTENTS

PAGE		PAGE	
48-Lead TSOP Pinout.....	3	Extended Status Register Definition	15
Pin Descriptions.....	4	Partition Configuration Register Definition.....	16
Simultaneous Operation Modes Allowed with Four Planes	5	Partition Configuration	16
Memory Map.....	6	1 Electrical Specifications.....	17
Identifier Codes and OTP Address for Read Operation	7	1.1 Absolute Maximum Ratings	17
Identifier Codes and OTP Address for Read Operation on Partition Configuration.....	7	1.2 Operating Conditions	17
OTP Block Address Map for OTP Program.....	8	1.2.1 Capacitance	18
Bus Operation.....	9	1.2.2 AC Input/Output Test Conditions	18
Command Definitions	10	1.2.3 DC Characteristics	19
Functions of Block Lock and Block Lock-Down.....	12	1.2.4 AC Characteristics - Read-Only Operations.....	21
Block Locking State Transitions upon Command Write.....	12	1.2.5 AC Characteristics - Write Operations	24
Block Locking State Transitions upon WP# Transition.....	13	1.2.6 Reset Operations	26
Status Register Definition.....	14	1.2.7 Block Erase, Full Chip Erase, (Page Buffer) Program and OTP Program Performance.....	27
		2 Related Document Information.....	28

LH28F640BFHE-PBTL90

64Mbit (4Mbit×16)

Page Mode Dual Work Flash MEMORY

- 64M density with 16Bit I/O Interface
- High Performance Reads
 - 90/35ns 8-Word Page Mode
- Configurative 4-Plane Dual Work
 - Flexible Partitioning
 - Read operations during Block Erase or (Page Buffer) Program
 - Status Register for Each Partition
- Low Power Operation
 - 2.7V Read and Write Operations
 - V_{CCQ} for Input/Output Power Supply Isolation
 - Automatic Power Savings Mode Reduces I_{CCR} in Static Mode
- Enhanced Code + Data Storage
 - 5 μ s Typical Erase/Program Suspends
- OTP (One Time Program) Block
 - 4-Word Factory-Programmed Area
 - 4-Word User-Programmable Area
- High Performance Program with Page Buffer
 - 16-Word Page Buffer
 - 5 μ s/Word (Typ.) at 12V V_{PP}
- Operating Temperature -40°C to +85°C
- CMOS Process (P-type silicon substrate)
- Flexible Blocking Architecture
 - Eight 4K-word Parameter Blocks
 - One-hundred and twenty-seven 32K-word Main Blocks
 - Bottom Parameter Location
- Enhanced Data Protection Features
 - Individual Block Lock and Block Lock-Down with Zero-Latency
 - All blocks are locked at power-up or device reset.
 - Absolute Protection with $V_{PP} \leq V_{PPLK}$
 - Block Erase, Full Chip Erase, (Page Buffer) Word Program Lockout during Power Transitions
- Automated Erase/Program Algorithms
 - 3.0V Low-Power 11 μ s/Word (Typ.) Programming
 - 12V No Glue Logic 9 μ s/Word (Typ.) Production Programming and 0.5s Erase (Typ.)
- Cross-Compatible Command Support
 - Basic Command Set
 - Common Flash Interface (CFI)
- Extended Cycling Capability
 - Minimum 100,000 Block Erase Cycles
- 48-Lead TSOP
- ETOXTM* Flash Technology
- Not designed or rated as radiation hardened

The product, which is 4-Plane Page Mode Dual Work (Simultaneous Read while Erase/Program) Flash memory, is a low power, high density, low cost, nonvolatile read/write storage solution for a wide range of applications. The product can operate at $V_{CC}=2.7V-3.6V$ and $V_{PP}=1.65V-3.6V$ or 11.7V-12.3V. Its low voltage operation capability greatly extends battery life for portable applications.

The product provides high performance asynchronous page mode. It allows code execution directly from Flash, thus eliminating time consuming wait states. Furthermore, its newly configurative partitioning architecture allows flexible dual work operation.

The memory array block architecture utilizes Enhanced Data Protection features, and provides separate Parameter and Main Blocks that provide maximum flexibility for safe nonvolatile code and data storage.

Fast program capability is provided through the use of high speed Page Buffer Program.

Special OTP (One Time Program) block provides an area to store permanent code such as a unique number.

* ETOX is a trademark of Intel Corporation.

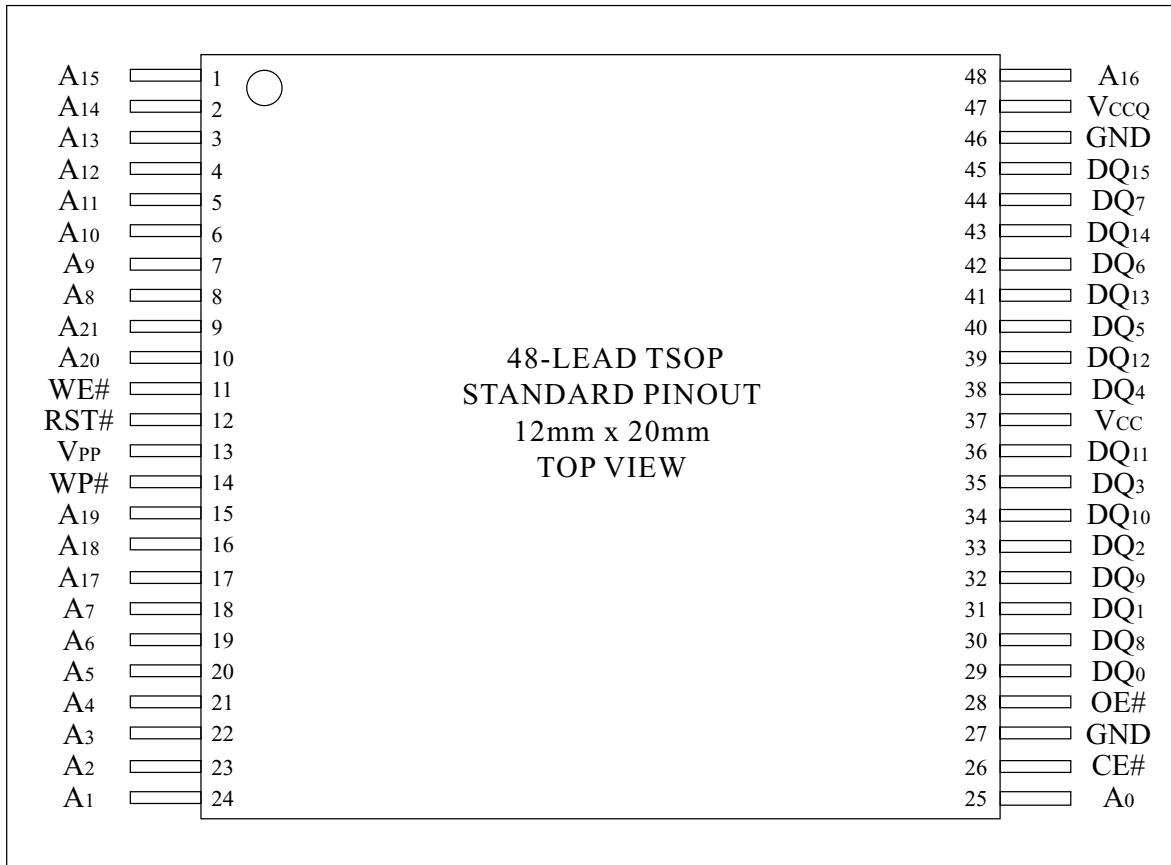

Figure 1. 48-Lead TSOP (Normal Bend) Pinout

Table 1. Pin Descriptions

Symbol	Type	Name and Function
A ₀ -A ₂₁	INPUT	ADDRESS INPUTS: Inputs for addresses. 64M: A ₀ -A ₂₁
DQ ₀ -DQ ₁₅	INPUT/ OUTPUT	DATA INPUTS/OUTPUTS: Inputs data and commands during CUI (Command User Interface) write cycles, outputs data during memory array, status register, query code, identifier code and partition configuration register code reads. Data pins float to high-impedance (High Z) when the chip or outputs are deselected. Data is internally latched during an erase or program cycle.
CE#	INPUT	CHIP ENABLE: Activates the device's control logic, input buffers, decoders and sense amplifiers. CE#-high (V _{IH}) deselected the device and reduces power consumption to standby levels.
RST#	INPUT	RESET: When low (V _{IL}), RST# resets internal automation and inhibits write operations which provides data protection. RST#-high (V _{IH}) enables normal operation. After power-up or reset mode, the device is automatically set to read array mode. RST# must be low during power-up/down.
OE#	INPUT	OUTPUT ENABLE: Gates the device's outputs during a read cycle.
WE#	INPUT	WRITE ENABLE: Controls writes to the CUI and array blocks. Addresses and data are latched on the rising edge of CE# or WE# (whichever goes high first).
WP#	INPUT	WRITE PROTECT: When WP# is V _{IL} , locked-down blocks cannot be unlocked. Erase or program operation can be executed to the blocks which are not locked and not locked-down. When WP# is V _{IH} , lock-down is disabled.
V _{PP}	INPUT	MONITORING POWER SUPPLY VOLTAGE: V _{PP} is not used for power supply pin. With V _{PP} ≤ V _{PPLK} , block erase, full chip erase, (page buffer) program or OTP program cannot be executed and should not be attempted. Applying 12V ± 0.3V to V _{PP} provides fast erasing or fast programming mode. In this mode, V _{PP} is power supply pin. Applying 12V ± 0.3V to V _{PP} during erase/program can only be done for a maximum of 1,000 cycles on each block. V _{PP} may be connected to 12V ± 0.3V for a total of 80 hours maximum. Use of this pin at 12V beyond these limits may reduce block cycling capability or cause permanent damage.
V _{CC}	SUPPLY	DEVICE POWER SUPPLY (2.7V-3.6V): With V _{CC} ≤ V _{LKO} , all write attempts to the flash memory are inhibited. Device operations at invalid V _{CC} voltage (see DC Characteristics) produce spurious results and should not be attempted.
V _{CCQ}	SUPPLY	INPUT/OUTPUT POWER SUPPLY (2.7V-3.6V): Power supply for all input/output pins.
GND	SUPPLY	GROUND: Do not float any ground pins.

Table 2. Simultaneous Operation Modes Allowed with Four Planes^(1,2)

IF ONE PARTITION IS:	THEN THE MODES ALLOWED IN THE OTHER PARTITION IS:										
	Read Array	Read ID/OTP	Read Status	Read Query	Word Program	Page Buffer Program	OTP Program	Block Erase	Full Chip Erase	Program Suspend	Block Erase Suspend
Read Array	X	X	X	X	X	X		X		X	X
Read ID/OTP	X	X	X	X	X	X		X		X	X
Read Status	X	X	X	X	X	X	X	X	X	X	X
Read Query	X	X	X	X	X	X		X		X	X
Word Program	X	X	X	X							X
Page Buffer Program	X	X	X	X							X
OTP Program			X								
Block Erase	X	X	X	X							
Full Chip Erase			X								
Program Suspend	X	X	X	X							X
Block Erase Suspend	X	X	X	X	X	X				X	

NOTES:

1. "X" denotes the operation available.

2. Configurative Partition Dual Work Restrictions:

Status register reflects partition state, not WSM (Write State Machine) state - this allows a status register for each partition. Only one partition can be erased or programmed at a time - no command queuing.
Commands must be written to an address within the block targeted by that command.

BLOCK NUMBER ADDRESS RANGE			BLOCK NUMBER ADDRESS RANGE				
PLANE3 (UNIFORM PLANE)	134	32K-WORD	3F8000H - 3FFFFFFH	PLANE1 (UNIFORM PLANE)	70	32K-WORD	1F8000H - 1FFFFFFH
	133	32K-WORD	3F0000H - 3F7FFFH		69	32K-WORD	1F0000H - 1F7FFFH
	132	32K-WORD	3E8000H - 3EFFFFH		68	32K-WORD	1E8000H - 1EFFFFH
	131	32K-WORD	3E0000H - 3E7FFFH		67	32K-WORD	1E0000H - 1E7FFFH
	130	32K-WORD	3D8000H - 3DFFFFFFH		66	32K-WORD	1D8000H - 1DFFFFFFH
	129	32K-WORD	3D0000H - 3D7FFFH		65	32K-WORD	1D0000H - 1D7FFFH
	128	32K-WORD	3C8000H - 3CFFFFH		64	32K-WORD	1C8000H - 1CFFFFH
	127	32K-WORD	3C0000H - 3C7FFFH		63	32K-WORD	1C0000H - 1C7FFFH
	126	32K-WORD	3B8000H - 3BFFFFH		62	32K-WORD	1B8000H - 1BFFFFH
	125	32K-WORD	3B0000H - 3B7FFFH		61	32K-WORD	1B0000H - 1B7FFFH
	124	32K-WORD	3A8000H - 3AFFFFH		60	32K-WORD	1A8000H - 1AFFFFH
	123	32K-WORD	3A0000H - 3A7FFFH		59	32K-WORD	1A0000H - 1A7FFFH
	122	32K-WORD	398000H - 39FFFFH		58	32K-WORD	198000H - 19FFFFH
	121	32K-WORD	390000H - 397FFFH		57	32K-WORD	190000H - 197FFFH
	120	32K-WORD	388000H - 38FFFFH		56	32K-WORD	188000H - 18FFFFH
	119	32K-WORD	380000H - 387FFFH		55	32K-WORD	180000H - 187FFFH
	118	32K-WORD	378000H - 37FFFFH		54	32K-WORD	178000H - 177FFFH
	117	32K-WORD	370000H - 377FFFH		53	32K-WORD	170000H - 177FFFH
	116	32K-WORD	368000H - 36FFFFH		52	32K-WORD	168000H - 16FFFFH
	115	32K-WORD	360000H - 367FFFH		51	32K-WORD	160000H - 167FFFH
	114	32K-WORD	358000H - 35FFFFH		50	32K-WORD	158000H - 15FFFFH
113	32K-WORD	350000H - 357FFFH	49	32K-WORD	150000H - 157FFFH		
112	32K-WORD	348000H - 34FFFFH	48	32K-WORD	148000H - 14FFFFH		
111	32K-WORD	340000H - 347FFFH	47	32K-WORD	140000H - 147FFFH		
110	32K-WORD	338000H - 33FFFFH	46	32K-WORD	138000H - 13FFFFH		
109	32K-WORD	330000H - 337FFFH	45	32K-WORD	130000H - 137FFFH		
108	32K-WORD	328000H - 32FFFFH	44	32K-WORD	128000H - 12FFFFH		
107	32K-WORD	320000H - 327FFFH	43	32K-WORD	120000H - 127FFFH		
106	32K-WORD	318000H - 31FFFFH	42	32K-WORD	118000H - 11FFFFH		
105	32K-WORD	310000H - 317FFFH	41	32K-WORD	110000H - 117FFFH		
104	32K-WORD	308000H - 30FFFFH	40	32K-WORD	108000H - 10FFFFH		
103	32K-WORD	300000H - 307FFFH	39	32K-WORD	100000H - 107FFFH		
PLANE2 (UNIFORM PLANE)	102	32K-WORD	2F8000H - 2FFFFFFH	PLANE0 (PARAMETER PLANE)	38	32K-WORD	0F8000H - 0FFFFFFH
	101	32K-WORD	2F0000H - 2F7FFFH		37	32K-WORD	0F0000H - 0F7FFFH
	100	32K-WORD	2E8000H - 2EFFFFH		36	32K-WORD	0E8000H - 0EFFFFH
	99	32K-WORD	2E0000H - 2E7FFFH		35	32K-WORD	0E0000H - 0E7FFFH
	98	32K-WORD	2D8000H - 2DFFFFFFH		34	32K-WORD	0D8000H - 0DFFFFH
	97	32K-WORD	2D0000H - 2D7FFFH		33	32K-WORD	0D0000H - 0D7FFFH
	96	32K-WORD	2C8000H - 2CFFFFH		32	32K-WORD	0C8000H - 0CFFFFH
	95	32K-WORD	2C0000H - 2C7FFFH		31	32K-WORD	0C0000H - 0C7FFFH
	94	32K-WORD	2B8000H - 2BFFFFH		30	32K-WORD	0B8000H - 0BFFFFH
	93	32K-WORD	2B0000H - 2B7FFFH		29	32K-WORD	0B0000H - 0B7FFFH
	92	32K-WORD	2A8000H - 2AFFFFH		28	32K-WORD	0A8000H - 0AFFFFH
	91	32K-WORD	2A0000H - 2A7FFFH		27	32K-WORD	0A0000H - 0A7FFFH
	90	32K-WORD	298000H - 29FFFFH		26	32K-WORD	098000H - 09FFFFH
	89	32K-WORD	290000H - 297FFFH		25	32K-WORD	090000H - 097FFFH
	88	32K-WORD	288000H - 28FFFFH		24	32K-WORD	088000H - 08FFFFH
	87	32K-WORD	280000H - 287FFFH		23	32K-WORD	080000H - 087FFFH
	86	32K-WORD	278000H - 27FFFFH		22	32K-WORD	078000H - 07FFFFH
	85	32K-WORD	270000H - 277FFFH		21	32K-WORD	070000H - 077FFFH
	84	32K-WORD	268000H - 26FFFFH		20	32K-WORD	068000H - 06FFFFH
	83	32K-WORD	260000H - 267FFFH		19	32K-WORD	060000H - 067FFFH
	82	32K-WORD	258000H - 25FFFFH		18	32K-WORD	058000H - 05FFFFH
81	32K-WORD	250000H - 257FFFH	17	32K-WORD	050000H - 057FFFH		
80	32K-WORD	248000H - 24FFFFH	16	32K-WORD	048000H - 04FFFFH		
79	32K-WORD	240000H - 247FFFH	15	32K-WORD	040000H - 047FFFH		
78	32K-WORD	238000H - 23FFFFH	14	32K-WORD	038000H - 03FFFFH		
77	32K-WORD	230000H - 237FFFH	13	32K-WORD	030000H - 037FFFH		
76	32K-WORD	228000H - 22FFFFH	12	32K-WORD	028000H - 02FFFFH		
75	32K-WORD	220000H - 227FFFH	11	32K-WORD	020000H - 027FFFH		
74	32K-WORD	218000H - 21FFFFH	10	32K-WORD	018000H - 01FFFFH		
73	32K-WORD	210000H - 217FFFH	9	32K-WORD	010000H - 017FFFH		
72	32K-WORD	208000H - 20FFFFH	8	32K-WORD	008000H - 00FFFFH		
71	32K-WORD	200000H - 207FFFH	7	4K-WORD	007000H - 007FFFH		
			6	4K-WORD	006000H - 006FFFH		
			5	4K-WORD	005000H - 005FFFH		
			4	4K-WORD	004000H - 004FFFH		
			3	4K-WORD	003000H - 003FFFH		
			2	4K-WORD	002000H - 002FFFH		
			1	4K-WORD	001000H - 001FFFH		
			0	4K-WORD	000000H - 000FFFH		

Figure 2. Memory Map (Bottom Parameter)

Table 3. Identifier Codes and OTP Address for Read Operation

	Code	Address [A ₁₅ -A ₀] ⁽¹⁾	Data [DQ ₁₅ -DQ ₀]	Notes
Manufacturer Code	Manufacturer Code	0000H	00B0H	
Device Code	Bottom Parameter Device Code	0001H	00B1H	2
Block Lock Configuration Code	Block is Unlocked	Block Address + 2	DQ ₀ = 0	3
	Block is Locked		DQ ₀ = 1	3
	Block is not Locked-Down		DQ ₁ = 0	3
	Block is Locked-Down		DQ ₁ = 1	3
Device Configuration Code	Partition Configuration Register	0006H	PCRC	4
OTP	OTP Lock	0080H	OTP-LK	5
	OTP	0081-0088H	OTP	6

NOTES:

1. The address A₂₁-A₁₆ are shown in below table for reading the manufacturer, device, lock configuration, device configuration code and OTP data.
2. Bottom parameter device has its parameter blocks in the plane0 (The lowest address).
3. DQ₁₅-DQ₂ are reserved for future implementation.
4. PCRC=Partition Configuration Register Code.
5. OTP-LK=OTP Block Lock configuration.
6. OTP=OTP Block data.

Table 4. Identifier Codes and OTP Address for Read Operation on Partition Configuration⁽¹⁾ (64M-bit device)

Partition Configuration Register ⁽²⁾			Address (64M-bit device)
PCR.10	PCR.9	PCR.8	[A ₂₁ -A ₁₆]
0	0	0	00H
0	0	1	00H or 10H
0	1	0	00H or 20H
1	0	0	00H or 30H
0	1	1	00H or 10H or 20H
1	1	0	00H or 20H or 30H
1	0	1	00H or 10H or 30H
1	1	1	00H or 10H or 20H or 30H

NOTES:

1. The address to read the identifier codes or OTP data is dependent on the partition which is selected when writing the Read Identifier Codes/OTP command (90H).
2. Refer to Table 12 for the partition configuration register.

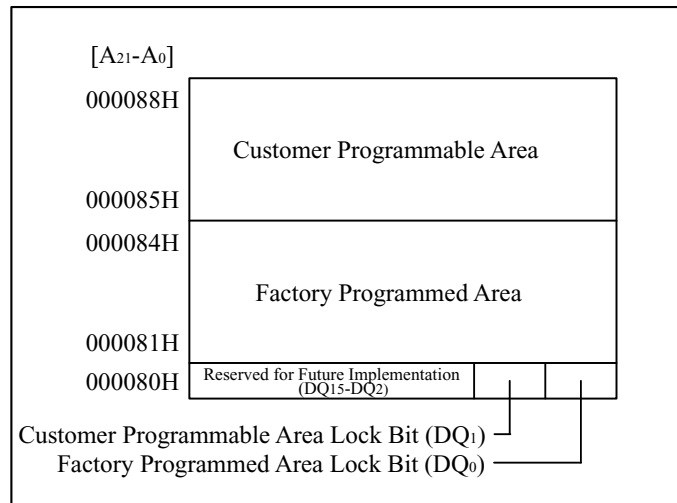

Figure 3. OTP Block Address Map for OTP Program
 (The area outside 80H~88H cannot be used.)

Table 5. Bus Operation^(1,2)

Mode	Notes	RST#	CE#	OE#	WE#	Address	V _{PP}	DQ ₀₋₁₅
Read Array	6	V _{IH}	V _{IL}	V _{IL}	V _{IH}	X	X	D _{OUT}
Output Disable		V _{IH}	V _{IL}	V _{IH}	V _{IH}	X	X	High Z
Standby		V _{IH}	V _{IH}	X	X	X	X	High Z
Reset	3	V _{IL}	X	X	X	X	X	High Z
Read Identifier Codes/OTP	6	V _{IH}	V _{IL}	V _{IL}	V _{IH}	See Table 3 and Table 4	X	See Table 3 and Table 4
Read Query	6,7	V _{IH}	V _{IL}	V _{IL}	V _{IH}	See Appendix	X	See Appendix
Write	4,5,6	V _{IH}	V _{IL}	V _{IH}	V _{IL}	X	X	D _{IN}

NOTES:

1. Refer to DC Characteristics. When $V_{PP} \leq V_{PPLK}$, memory contents can be read, but cannot be altered.
2. X can be V_{IL} or V_{IH} for control pins and addresses, and V_{PPLK} or V_{PPH1/2} for V_{PP}. See DC Characteristics for V_{PPLK} and V_{PPH1/2} voltages.
3. RST# at GND±0.2V ensures the lowest power consumption.
4. Command writes involving block erase, (page buffer) program or OTP program are reliably executed when V_{PP}=V_{PPH1/2} and V_{CC}=2.7V-3.6V.
 Command writes involving full chip erase are reliably executed when V_{PP}=V_{PPH1} and V_{CC}=2.7V-3.6V.
5. Refer to Table 6 for valid D_{IN} during a write operation.
6. Never hold OE# low and WE# low at the same timing.
7. Refer to Appendix of LH28F640BF series for more information about query code.

Table 6. Command Definitions⁽¹⁾

Command	Bus Cycles Req'd	Notes	First Bus Cycle			Second Bus Cycle		
			Oper ⁽¹⁾	Addr ⁽²⁾	Data	Oper ⁽¹⁾	Addr ⁽²⁾	Data ⁽³⁾
Read Array	1		Write	PA	FFH			
Read Identifier Codes/OTP	≥ 2	4	Write	PA	90H	Read	IA or OA	ID or OD
Read Query	≥ 2	4	Write	PA	98H	Read	QA	QD
Read Status Register	2		Write	PA	70H	Read	PA	SRD
Clear Status Register	1		Write	PA	50H			
Block Erase	2	5	Write	BA	20H	Write	BA	D0H
Full Chip Erase	2	5,9	Write	X	30H	Write	X	D0H
Program	2	5,6	Write	WA	40H or 10H	Write	WA	WD
Page Buffer Program	≥ 4	5,7	Write	WA	E8H	Write	WA	N-1
Block Erase and (Page Buffer) Program Suspend	1	8,9	Write	PA	B0H			
Block Erase and (Page Buffer) Program Resume	1	8,9	Write	PA	D0H			
Set Block Lock Bit	2		Write	BA	60H	Write	BA	01H
Clear Block Lock Bit	2	10	Write	BA	60H	Write	BA	D0H
Set Block Lock-down Bit	2		Write	BA	60H	Write	BA	2FH
OTP Program	2	9	Write	OA	C0H	Write	OA	OD
Set Partition Configuration Register	2		Write	PCRC	60H	Write	PCRC	04H

NOTES:

- Bus operations are defined in Table 5.
- The address which is written at the first bus cycle should be the same as the address which is written at the second bus cycle.
X=Any valid address within the device.
PA=Address within the selected partition.
IA=Identifier codes address (See Table 3 and Table 4).
QA=Query codes address. Refer to Appendix of LH28F640BF series for details.
BA=Address within the block being erased, set/cleared block lock bit or set block lock-down bit.
WA=Address of memory location for the Program command or the first address for the Page Buffer Program command.
OA=Address of OTP block to be read or programmed (See Figure 3).
PCRC=Partition configuration register code presented on the address A₀-A₁₅.
- ID=Data read from identifier codes. (See Table 3 and Table 4).
QD=Data read from query database. Refer to Appendix of LH28F640BF series for details.
SRD=Data read from status register. See Table 10 and Table 11 for a description of the status register bits.
WD=Data to be programmed at location WA. Data is latched on the rising edge of WE# or CE# (whichever goes high first) during command write cycles.
OD=Data within OTP block. Data is latched on the rising edge of WE# or CE# (whichever goes high first) during command write cycles.
N-1=N is the number of the words to be loaded into a page buffer.
- Following the Read Identifier Codes/OTP command, read operations access manufacturer code, device code, block lock configuration code, partition configuration register code and the data within OTP block (See Table 3 and Table 4). The Read Query command is available for reading CFI (Common Flash Interface) information.
- Block erase, full chip erase or (page buffer) program cannot be executed when the selected block is locked. Unlocked block can be erased or programmed when RST# is V_{IH}.
- Either 40H or 10H are recognized by the CUI (Command User Interface) as the program setup.
- Following the third bus cycle, inputs the program sequential address and write data of "N" times. Finally, input the any valid address within the target partition to be programmed and the confirm command (D0H). Refer to Appendix of

LH28F640BF series for details.

8. If the program operation in one partition is suspended and the erase operation in other partition is also suspended, the suspended program operation should be resumed first, and then the suspended erase operation should be resumed next.
9. Full chip erase and OTP program operations can not be suspended. The OTP Program command can not be accepted while the block erase operation is being suspended.
10. Following the Clear Block Lock Bit command, block which is not locked-down is unlocked when WP# is V_{IL} . When WP# is V_{IH} , lock-down bit is disabled and the selected block is unlocked regardless of lock-down configuration.
11. Commands other than those shown above are reserved by SHARP for future device implementations and should not be used.

onlinecomponents.com

Table 7. Functions of Block Lock⁽⁵⁾ and Block Lock-Down

Current State					Erase/Program Allowed ⁽²⁾
State	WP#	DQ ₁ ⁽¹⁾	DQ ₀ ⁽¹⁾	State Name	
[000]	0	0	0	Unlocked	Yes
[001] ⁽³⁾	0	0	1	Locked	No
[011]	0	1	1	Locked-down	No
[100]	1	0	0	Unlocked	Yes
[101] ⁽³⁾	1	0	1	Locked	No
[110] ⁽⁴⁾	1	1	0	Lock-down Disable	Yes
[111]	1	1	1	Lock-down Disable	No

NOTES:

- DQ₀=1: a block is locked; DQ₀=0: a block is unlocked.
DQ₁=1: a block is locked-down; DQ₁=0: a block is not locked-down.
- Erase and program are general terms, respectively, to express: block erase, full chip erase and (page buffer) program operations.
- At power-up or device reset, all blocks default to locked state and are not locked-down, that is, [001] (WP#=0) or [101] (WP#=1), regardless of the states before power-off or reset operation.
- When WP# is driven to V_{IL} in [110] state, the state changes to [011] and the blocks are automatically locked.
- OTP (One Time Program) block has the lock function which is different from those described above.

Table 8. Block Locking State Transitions upon Command Write⁽⁴⁾

Current State				Result after Lock Command Written (Next State)		
State	WP#	DQ ₁	DQ ₀	Set Lock ⁽¹⁾	Clear Lock ⁽¹⁾	Set Lock-down ⁽¹⁾
[000]	0	0	0	[001]	No Change	[011] ⁽²⁾
[001]	0	0	1	No Change ⁽³⁾	[000]	[011]
[011]	0	1	1	No Change	No Change	No Change
[100]	1	0	0	[101]	No Change	[111] ⁽²⁾
[101]	1	0	1	No Change	[100]	[111]
[110]	1	1	0	[111]	No Change	[111] ⁽²⁾
[111]	1	1	1	No Change	[110]	No Change

NOTES:

- "Set Lock" means Set Block Lock Bit command, "Clear Lock" means Clear Block Lock Bit command and "Set Lock-down" means Set Block Lock-Down Bit command.
- When the Set Block Lock-Down Bit command is written to the unlocked block (DQ₀=0), the corresponding block is locked-down and automatically locked at the same time.
- "No Change" means that the state remains unchanged after the command written.
- In this state transitions table, assumes that WP# is not changed and fixed V_{IL} or V_{IH}.

Table 9. Block Locking State Transitions upon WP# Transition⁽⁴⁾

Previous State	Current State				Result after WP# Transition (Next State)	
	State	WP#	DQ ₁	DQ ₀	WP#=0→1 ⁽¹⁾	WP#=1→0 ⁽¹⁾
-	[000]	0	0	0	[100]	-
-	[001]	0	0	1	[101]	-
[110] ⁽²⁾	[011]	0	1	1	[110]	-
Other than [110] ⁽²⁾					[111]	-
-	[100]	1	0	0	-	[000]
-	[101]	1	0	1	-	[001]
-	[110]	1	1	0	-	[011] ⁽³⁾
-	[111]	1	1	1	-	[011]

NOTES:

1. "WP#=0→1" means that WP# is driven to V_{IH} and "WP#=1→0" means that WP# is driven to V_{IL}.
2. State transition from the current state [011] to the next state depends on the previous state.
3. When WP# is driven to V_{IL} in [110] state, the state changes to [011] and the blocks are automatically locked.
4. In this state transitions table, assumes that lock configuration commands are not written in previous, current and next state.

Table 10. Status Register Definition

R	R	R	R	R	R	R	R
15	14	13	12	11	10	9	8
WSMS	BESS	BEFCES	PBPOPS	VPPS	PBPSS	DPS	R
7	6	5	4	3	2	1	0

<p>SR.15 - SR.8 = RESERVED FOR FUTURE ENHANCEMENTS (R)</p> <p>SR.7 = WRITE STATE MACHINE STATUS (WSMS) 1 = Ready 0 = Busy</p> <p>SR.6 = BLOCK ERASE SUSPEND STATUS (BESS) 1 = Block Erase Suspended 0 = Block Erase in Progress/Completed</p> <p>SR.5 = BLOCK ERASE AND FULL CHIP ERASE STATUS (BEFCES) 1 = Error in Block Erase or Full Chip Erase 0 = Successful Block Erase or Full Chip Erase</p> <p>SR.4 = (PAGE BUFFER) PROGRAM AND OTP PROGRAM STATUS (PBPOPS) 1 = Error in (Page Buffer) Program or OTP Program 0 = Successful (Page Buffer) Program or OTP Program</p> <p>SR.3 = V_{pp} STATUS (VPPS) 1 = V_{pp} LOW Detect, Operation Abort 0 = V_{pp} OK</p> <p>SR.2 = (PAGE BUFFER) PROGRAM SUSPEND STATUS (PBPSS) 1 = (Page Buffer) Program Suspended 0 = (Page Buffer) Program in Progress/Completed</p> <p>SR.1 = DEVICE PROTECT STATUS (DPS) 1 = Erase or Program Attempted on a Locked Block, Operation Abort 0 = Unlocked</p> <p>SR.0 = RESERVED FOR FUTURE ENHANCEMENTS (R)</p>	<p>NOTES:</p> <p>Status Register indicates the status of the partition, not WSM (Write State Machine). Even if the SR.7 is "1", the WSM may be occupied by the other partition when the device is set to 2, 3 or 4 partitions configuration.</p> <p>Check SR.7 to determine block erase, full chip erase, (page buffer) program or OTP program completion. SR.6 - SR.1 are invalid while SR.7="0".</p> <p>If both SR.5 and SR.4 are "1"s after a block erase, full chip erase, (page buffer) program, set/clear block lock bit, set block lock-down bit, set partition configuration register attempt, an improper command sequence was entered.</p> <p>SR.3 does not provide a continuous indication of V_{pp} level. The WSM interrogates and indicates the V_{pp} level only after Block Erase, Full Chip Erase, (Page Buffer) Program or OTP Program command sequences. SR.3 is not guaranteed to report accurate feedback when V_{pp}≠V_{ppH1}, V_{ppH2} or V_{ppLK}.</p> <p>SR.1 does not provide a continuous indication of block lock bit. The WSM interrogates the block lock bit only after Block Erase, Full Chip Erase, (Page Buffer) Program or OTP Program command sequences. It informs the system, depending on the attempted operation, if the block lock bit is set. Reading the block lock configuration codes after writing the Read Identifier Codes/OTP command indicates block lock bit status.</p> <p>SR.15 - SR.8 and SR.0 are reserved for future use and should be masked out when polling the status register.</p>
--	--

Table 11. Extended Status Register Definition

R	R	R	R	R	R	R	R
15	14	13	12	11	10	9	8
SMS	R	R	R	R	R	R	R
7	6	5	4	3	2	1	0

<p>XSR.15-8 = RESERVED FOR FUTURE ENHANCEMENTS (R)</p> <p>XSR.7 = STATE MACHINE STATUS (SMS) 1 = Page Buffer Program available 0 = Page Buffer Program not available</p> <p>XSR.6-0 = RESERVED FOR FUTURE ENHANCEMENTS (R)</p>	<p>NOTES:</p> <p>After issue a Page Buffer Program command (E8H), XSR.7="1" indicates that the entered command is accepted. If XSR.7 is "0", the command is not accepted and a next Page Buffer Program command (E8H) should be issued again to check if page buffer is available or not.</p> <p>XSR.15-8 and XSR.6-0 are reserved for future use and should be masked out when polling the extended status register.</p>
--	---

onlinecomponents.com

Table 12. Partition Configuration Register Definition

R	R	R	R	R	PC2	PC1	PC0
15	14	13	12	11	10	9	8
R	R	R	R	R	R	R	R
7	6	5	4	3	2	1	0

<p>PCR.15-11 = RESERVED FOR FUTURE ENHANCEMENTS (R)</p> <p>PCR.10-8 = PARTITION CONFIGURATION (PC2-0)</p> <p>000 = No partitioning. Dual Work is not allowed.</p> <p>001 = Plane1-3 are merged into one partition. (default in a bottom parameter device)</p> <p>010 = Plane 0-1 and Plane2-3 are merged into one partition respectively.</p> <p>100 = Plane 0-2 are merged into one partition. (default in a top parameter device)</p> <p>011 = Plane 2-3 are merged into one partition. There are three partitions in this configuration. Dual work operation is available between any two partitions.</p> <p>110 = Plane 0-1 are merged into one partition. There are three partitions in this configuration. Dual work operation is available between any two partitions.</p> <p>101 = Plane 1-2 are merged into one partition. There are three partitions in this configuration. Dual work operation is available between any two partitions.</p>	<p>111 = There are four partitions in this configuration. Each plane corresponds to each partition respectively. Dual work operation is available between any two partitions.</p> <p>PCR.7-0 = RESERVED FOR FUTURE ENHANCEMENTS (R)</p> <p>NOTES:</p> <p>After power-up or device reset, PCR10-8 (PC2-0) is set to "001" in a bottom parameter device and "100" in a top parameter device.</p> <p>See Figure 4 for the detail on partition configuration.</p> <p>PCR.15-11 and PCR.7-0 are reserved for future use and should be masked out when polling the partition configuration register.</p>
--	--

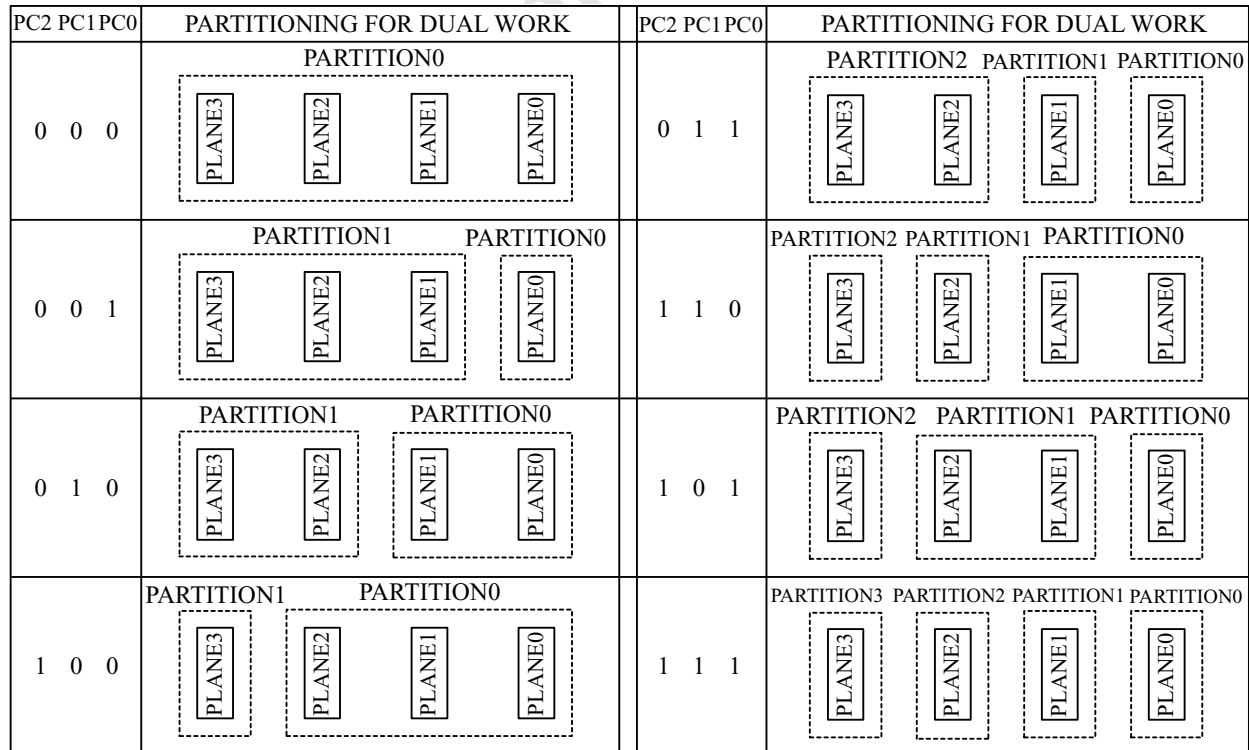

Figure 4. Partition Configuration

1 Electrical Specifications

1.1 Absolute Maximum Ratings*

Operating Temperature

During Read, Erase and Program ...-40°C to +85°C (1)

Storage Temperature

During under Bias..... -40°C to +85°C

During non Bias..... -65°C to +125°C

Voltage On Any Pin

(except V_{CC} and V_{PP})..... -0.5V to $V_{CC}+0.5V$ (2)

V_{CC} and V_{CCQ} Supply Voltage -0.2V to +3.9V (2)

V_{PP} Supply Voltage -0.2V to +12.6V (2, 3, 4)

Output Short Circuit Current 100mA (5)

***WARNING:** Stressing the device beyond the "Absolute Maximum Ratings" may cause permanent damage. These are stress ratings only. Operation beyond the "Operating Conditions" is not recommended and extended exposure beyond the "Operating Conditions" may affect device reliability.

NOTES:

1. Operating temperature is for extended temperature product defined by this specification.
2. All specified voltages are with respect to GND. Minimum DC voltage is -0.5V on input/output pins and -0.2V on V_{CC} and V_{PP} pins. During transitions, this level may undershoot to -2.0V for periods <20ns. Maximum DC voltage on input/output pins is $V_{CC}+0.5V$ which, during transitions, may overshoot to $V_{CC}+2.0V$ for periods <20ns.
3. Maximum DC voltage on V_{PP} may overshoot to +13.0V for periods <20ns.
4. V_{PP} erase/program voltage is normally 2.7V-3.6V. Applying 11.7V-12.3V to V_{PP} during erase/program can be done for a maximum of 1,000 cycles on the main blocks and 1,000 cycles on the parameter blocks. V_{PP} may be connected to 11.7V-12.3V for a total of 80 hours maximum.
5. Output shorted for no more than one second. No more than one output shorted at a time.

1.2 Operating Conditions

Parameter	Symbol	Min.	Typ.	Max.	Unit	Notes
Operating Temperature	T_A	-40	+25	+85	°C	
V_{CC} Supply Voltage	V_{CC}	2.7	3.0	3.6	V	1
I/O Supply Voltage	V_{CCQ}	2.7	3.0	3.6	V	1
V_{PP} Voltage when Used as a Logic Control	V_{PPH1}	1.65	3.0	3.6	V	1
V_{PP} Supply Voltage	V_{PPH2}	11.7	12	12.3	V	1, 2
Main Block Erase Cycling: $V_{PP}=3.0V$		100,000			Cycles	
Parameter Block Erase Cycling: $V_{PP}=3.0V$		100,000			Cycles	
Main Block Erase Cycling: $V_{PP}=12V$, 80 hrs.				1,000	Cycles	
Parameter Block Erase Cycling: $V_{PP}=12V$, 80 hrs.				1,000	Cycles	
Maximum V_{PP} hours at 12V				80	Hours	

NOTES:

1. See DC Characteristics tables for voltage range-specific specification.
2. Applying $V_{PP}=11.7V-12.3V$ during a erase or program can be done for a maximum of 1,000 cycles on the main blocks and 1,000 cycles on the parameter blocks. A permanent connection to $V_{PP}=11.7V-12.3V$ is not allowed and can cause damage to the device.

1.2.1 Capacitance⁽¹⁾ ($T_A=+25^\circ\text{C}$, $f=1\text{MHz}$)

Parameter	Symbol	Condition	Min.	Typ.	Max.	Unit
Input Capacitance	C_{IN}	$V_{IN}=0.0\text{V}$		6	8	pF
Output Capacitance	C_{OUT}	$V_{OUT}=0.0\text{V}$		10	12	pF

NOTE:

1. Sampled, not 100% tested.

1.2.2 AC Input/Output Test Conditions

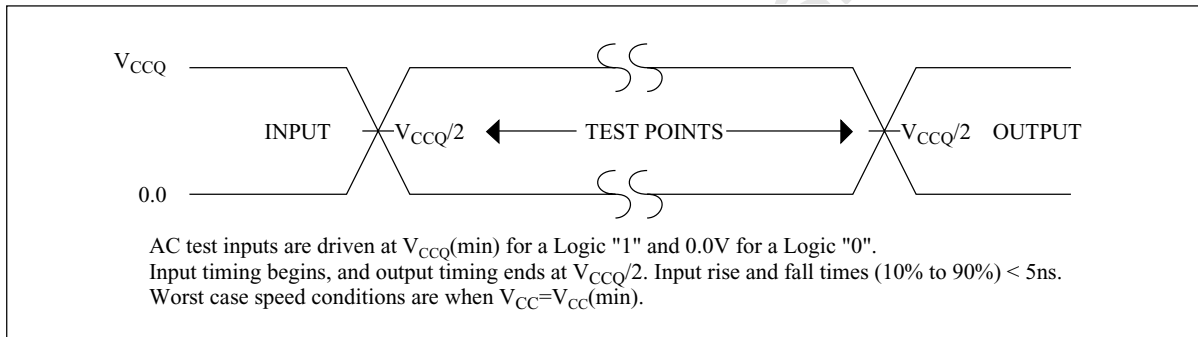

Figure 5. Transient Input/Output Reference Waveform for $V_{CC}=2.7\text{V}-3.6\text{V}$

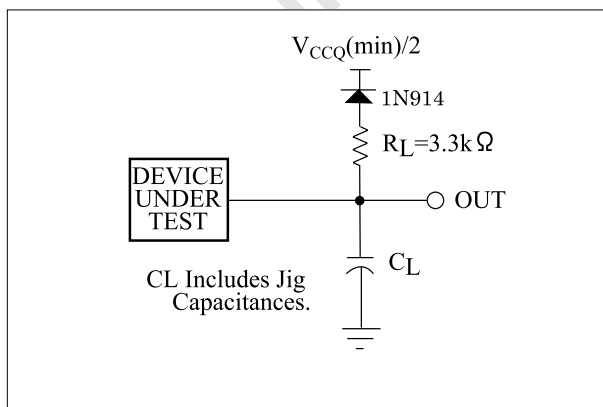

Figure 6. Transient Equivalent Testing Load Circuit

Table 13. Configuration Capacitance Loading Value

Test Configuration	C_L (pF)
$V_{CC}=2.7\text{V}-3.6\text{V}$	50

1.2.3 DC Characteristics

$V_{CC}=2.7V-3.6V$

Symbol	Parameter	Notes	Min.	Typ.	Max.	Unit	Test Conditions
I_{LI}	Input Load Current	1	-1.0		+1.0	μA	$V_{CC}=V_{CCMax.}$,
I_{LO}	Output Leakage Current	1	-1.0		+1.0	μA	$V_{CCQ}=V_{CCQMax.}$, $V_{IN}/V_{OUT}=V_{CCQ}$ or GND
I_{CCS}	V_{CC} Standby Current	1		4	20	μA	$V_{CC}=V_{CCMax.}$, CE#=RST#= $V_{CCQ}\pm 0.2V$, WP#=V _{CCQ} or GND
I_{CCAS}	V_{CC} Automatic Power Savings Current	1,4		4	20	μA	$V_{CC}=V_{CCMax.}$, CE#=GND $\pm 0.2V$, WP#=V _{CCQ} or GND
I_{CCD}	V_{CC} Reset Power-Down Current	1		4	20	μA	RST#=GND $\pm 0.2V$
I_{CCR}	Average V_{CC} Read Current Normal Mode	1,7		15	25	mA	$V_{CC}=V_{CCMax.}$, CE#=V _{IL} , OE#=V _{IH} , f=5MHz
	Average V_{CC} Read Current Page Mode	8 Word Read	1,7	5	10	mA	
I_{CCW}	V_{CC} (Page Buffer) Program Current	1,5,7		20	60	mA	$V_{PP}=V_{PPH1}$
		1,5,7		10	20	mA	$V_{PP}=V_{PPH2}$
I_{CCE}	V_{CC} Block Erase, Full Chip Erase Current	1,5,7		10	30	mA	$V_{PP}=V_{PPH1}$
		1,5,7		10	30	mA	$V_{PP}=V_{PPH2}$
I_{CCWS} I_{CCES}	V_{CC} (Page Buffer) Program or Block Erase Suspend Current	1,2,7		10	200	μA	CE#=V _{IH}
I_{PPS} I_{PPR}	V_{PP} Standby or Read Current	1,6,7		2	5	μA	$V_{PP}\leq V_{CC}$
I_{PPW}	V_{PP} (Page Buffer) Program Current	1,5,6,7		2	5	μA	$V_{PP}=V_{PPH1}$
		1,5,6,7		10	30	mA	$V_{PP}=V_{PPH2}$
I_{PPE}	V_{PP} Block Erase, Full Chip Erase Current	1,5,6,7		2	5	μA	$V_{PP}=V_{PPH1}$
		1,5,6,7		5	15	mA	$V_{PP}=V_{PPH2}$
I_{PPWS}	V_{PP} (Page Buffer) Program Suspend Current	1,6,7		2	5	μA	$V_{PP}=V_{PPH1}$
		1,6,7		10	200	μA	$V_{PP}=V_{PPH2}$
I_{PPES}	V_{PP} Block Erase Suspend Current	1,6,7		2	5	μA	$V_{PP}=V_{PPH1}$
		1,6,7		10	200	μA	$V_{PP}=V_{PPH2}$

DC Characteristics (Continued)

$$V_{CC}=2.7V-3.6V$$

Symbol	Parameter	Notes	Min.	Typ.	Max.	Unit	Test Conditions
V _{IL}	Input Low Voltage	5	-0.4		0.4	V	
V _{IH}	Input High Voltage	5	2.4		V _{CCQ} +0.4	V	
V _{OL}	Output Low Voltage	5			0.2	V	V _{CC} =V _{CC} Min., V _{CCQ} =V _{CCQ} Min., I _{OL} =100μA
V _{OH}	Output High Voltage	5	V _{CCQ} -0.2			V	V _{CC} =V _{CC} Min., V _{CCQ} =V _{CCQ} Min., I _{OH} =-100μA
V _{PPLK}	V _{PP} Lockout during Normal Operations	3,5,6			0.4	V	
V _{PPH1}	V _{PP} during Block Erase, Full Chip Erase, (Page Buffer) Program or OTP Program Operations	6	1.65	3.0	3.6	V	
V _{PPH2}	V _{PP} during Block Erase, (Page Buffer) Program or OTP Program Operations	6	11.7	12	12.3	V	
V _{LKO}	V _{CC} Lockout Voltage		1.5			V	

NOTES:

- All currents are in RMS unless otherwise noted. Typical values are the reference values at V_{CC}=3.0V and T_A=+25°C unless V_{CC} is specified.
- I_{CCWS} and I_{CCES} are specified with the device de-selected. If read or (page buffer) program is executed while in block erase suspend mode, the device's current draw is the sum of I_{CCES} and I_{CCR} or I_{CCW}. If read is executed while in (page buffer) program suspend mode, the device's current draw is the sum of I_{CCWS} and I_{CCR}.
- Block erase, full chip erase, (page buffer) program and OTP program are inhibited when V_{PP} ≤ V_{PPLK}, and not guaranteed in the range between V_{PPLK}(max.) and V_{PPH1}(min.), between V_{PPH1}(max.) and V_{PPH2}(min.) and above V_{PPH2}(max.).
- The Automatic Power Savings (APS) feature automatically places the device in power save mode after read cycle completion. Standard address access timings (t_{AVQV}) provide new data when addresses are changed.
- Sampled, not 100% tested.
- V_{PP} is not used for power supply pin. With V_{PP} ≤ V_{PPLK}, block erase, full chip erase, (page buffer) program and OTP program cannot be executed and should not be attempted.
Applying 12V±0.3V to V_{PP} provides fast erasing or fast programming mode. In this mode, V_{PP} is power supply pin and supplies the memory cell current for block erasing and (page buffer) programming. Use similar power supply trace widths and layout considerations given to the V_{CC} power bus.
Applying 12V±0.3V to V_{PP} during erase/program can only be done for a maximum of 1,000 cycles on each block. V_{PP} may be connected to 12V±0.3V for a total of 80 hours maximum.
- The operating current in dual work is the sum of the operating current (read, erase, program) in each plane.

1.2.4 AC Characteristics - Read-Only Operations⁽¹⁾

$V_{CC}=2.7V-3.6V$, $T_A=-40^{\circ}C$ to $+85^{\circ}C$

Symbol	Parameter	Notes	Min.	Max.	Unit
t_{AVAV}	Read Cycle Time		90		ns
t_{AVQV}	Address to Output Delay			90	ns
t_{ELQV}	CE# to Output Delay	3		90	ns
t_{APA}	Page Address Access Time			35	ns
t_{GLQV}	OE# to Output Delay	3		20	ns
t_{PHQV}	RST# High to Output Delay			150	ns
t_{EHQZ} , t_{GHQZ}	CE# or OE# to Output in High Z, Whichever Occurs First	2		20	ns
t_{ELQX}	CE# to Output in Low Z	2	0		ns
t_{GLQX}	OE# to Output in Low Z	2	0		ns
t_{OH}	Output Hold from First Occurring Address, CE# or OE# change	2	0		ns

NOTES:

1. See AC input/output reference waveform for timing measurements and maximum allowable input slew rate.
2. Sampled, not 100% tested.
3. OE# may be delayed up to $t_{ELQV} - t_{GLQV}$ after the falling edge of CE# without impact to t_{ELQV} .

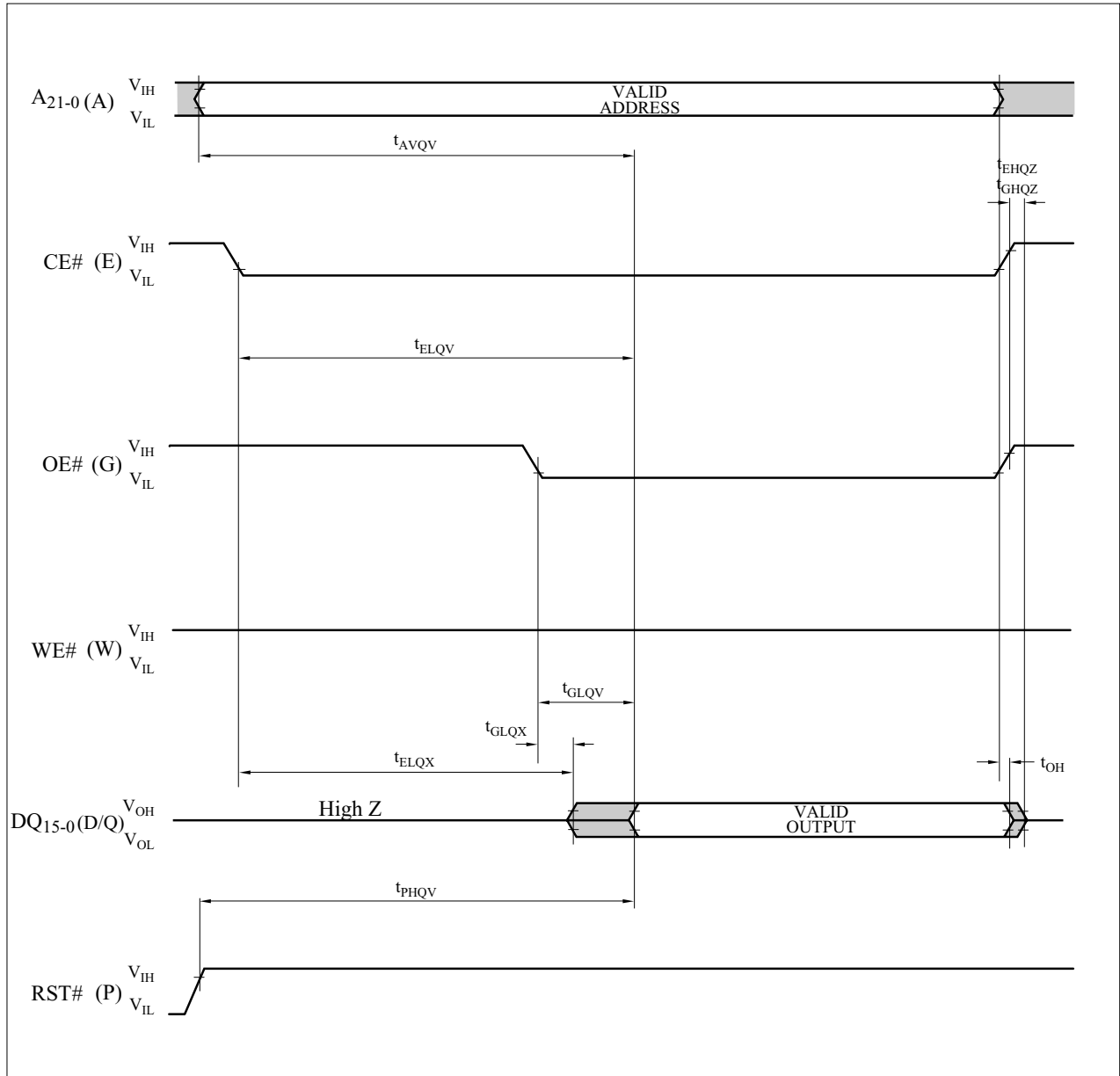

Figure 7. AC Waveform for Single Asynchronous Read Operations from Status Register, Identifier Codes, OTP Block or Query Code

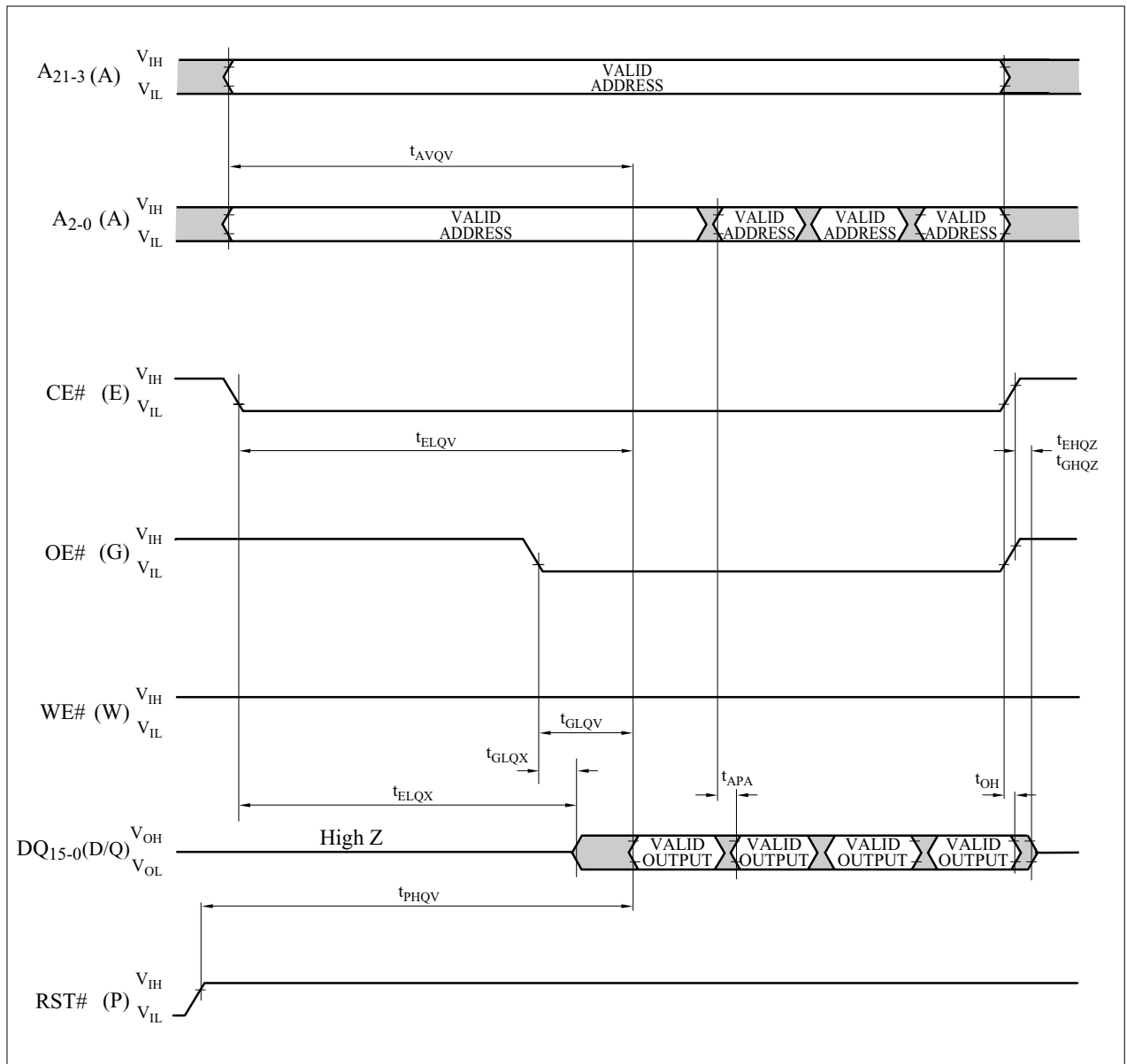

Figure 8. AC Waveform for Asynchronous Page Mode Read Operations from Main Blocks or Parameter Blocks

1.2.5 AC Characteristics - Write Operations^{(1), (2)}

$V_{CC}=2.7V-3.6V$, $T_A=-40^{\circ}C$ to $+85^{\circ}C$

Symbol	Parameter	Notes	Min.	Max.	Unit
t_{AVAV}	Write Cycle Time		90		ns
t_{PHWL} (t_{PHEL})	RST# High Recovery to WE# (CE#) Going Low	3	150		ns
t_{ELWL} (t_{WLEL})	CE# (WE#) Setup to WE# (CE#) Going Low	4	0		ns
t_{WLWH} (t_{ELEH})	WE# (CE#) Pulse Width	4	60		ns
t_{DVWH} (t_{DVEH})	Data Setup to WE# (CE#) Going High	8	40		ns
t_{AVWH} (t_{AVEH})	Address Setup to WE# (CE#) Going High	8	50		ns
t_{WHEH} (t_{EHWH})	CE# (WE#) Hold from WE# (CE#) High		0		ns
t_{WHDX} (t_{EHDX})	Data Hold from WE# (CE#) High		0		ns
t_{WHAX} (t_{EHAX})	Address Hold from WE# (CE#) High		0		ns
t_{WHWL} (t_{EHEL})	WE# (CE#) Pulse Width High	5	30		ns
t_{SHWH} (t_{SHEH})	WP# High Setup to WE# (CE#) Going High	3	0		ns
t_{VVWH} (t_{VVEH})	V_{PP} Setup to WE# (CE#) Going High	3	200		ns
t_{WHGL} (t_{EHGL})	Write Recovery before Read		30		ns
t_{QVSL}	WP# High Hold from Valid SRD	3, 6	0		ns
t_{QVVL}	V_{PP} Hold from Valid SRD	3, 6	0		ns
t_{WHR0} (t_{EHR0})	WE# (CE#) High to SR.7 Going "0"	3, 7		t_{AVQV}^{+} 50	ns

NOTES:

- The timing characteristics for reading the status register during block erase, full chip erase, (page buffer) program and OTP program operations are the same as during read-only operations. Refer to AC Characteristics for read-only operations.
- A write operation can be initiated and terminated with either CE# or WE#.
- Sampled, not 100% tested.
- Write pulse width (t_{WP}) is defined from the falling edge of CE# or WE# (whichever goes low last) to the rising edge of CE# or WE# (whichever goes high first). Hence, $t_{WP}=t_{WLWH}=t_{ELEH}=t_{WLEH}=t_{ELWH}$.
- Write pulse width high (t_{WPH}) is defined from the rising edge of CE# or WE# (whichever goes high first) to the falling edge of CE# or WE# (whichever goes low last). Hence, $t_{WPH}=t_{WHWL}=t_{EHEL}=t_{WHEL}=t_{EHWL}$.
- V_{PP} should be held at $V_{PP}=V_{PPH1/2}$ until determination of block erase, (page buffer) program or OTP program success (SR.1/3/4/5=0) and held at $V_{PP}=V_{PPH1}$ until determination of full chip erase success (SR.1/3/5=0).
- t_{WHR0} (t_{EHR0}) after the Read Query or Read Identifier Codes/OTP command= $t_{AVQV}^{+}+100ns$.
- Refer to Table 6 for valid address and data for block erase, full chip erase, (page buffer) program, OTP program or lock bit configuration.

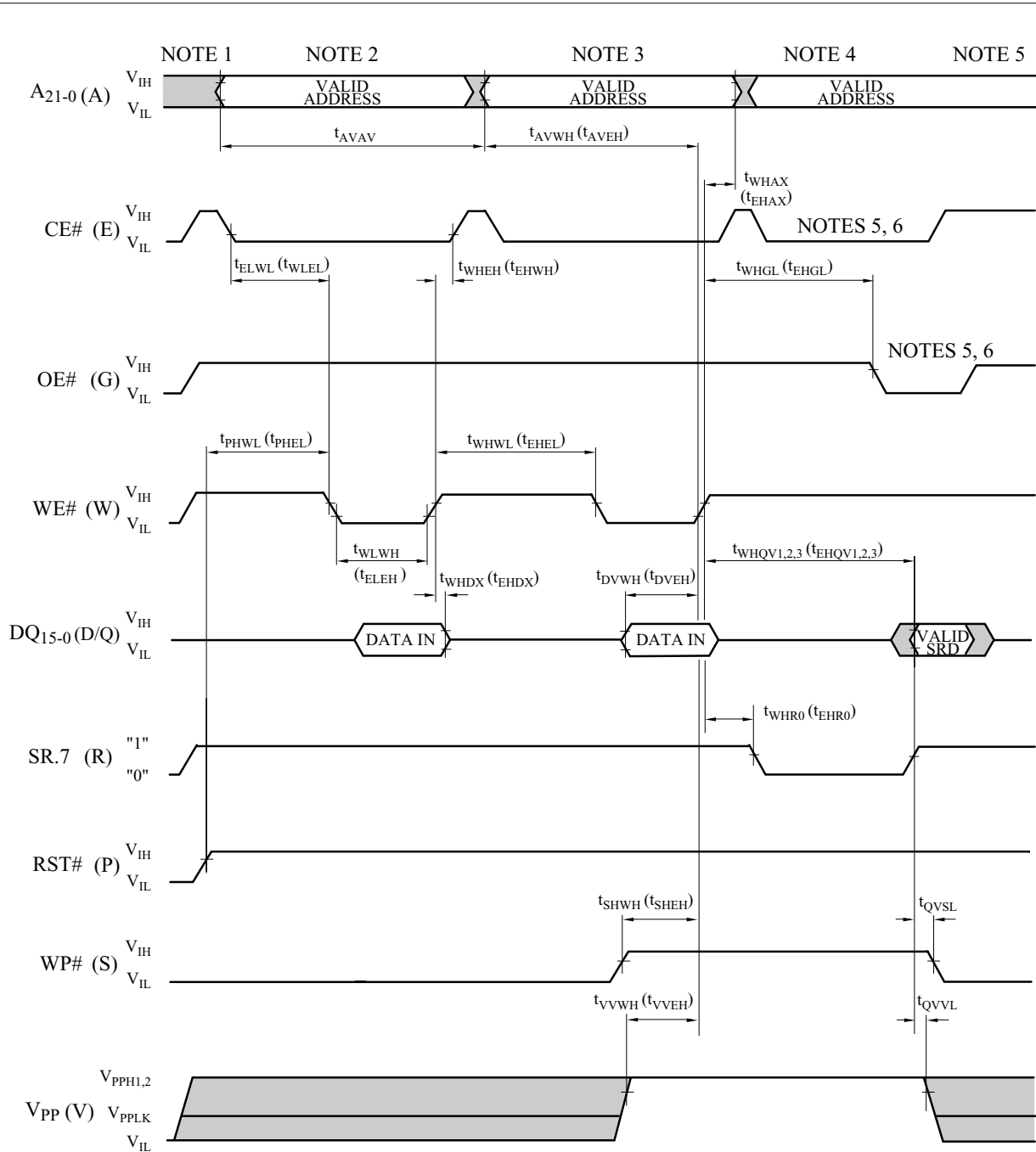

NOTES:

1. V_{CC} power-up and standby.
2. Write each first cycle command.
3. Write each second cycle command or valid address and data.
4. Automated erase or program delay.
5. Read status register data.
6. For read operation, OE# and CE# must be driven active, and WE# de-asserted.

Figure 9. AC Waveform for Write Operations

1.2.6 Reset Operations

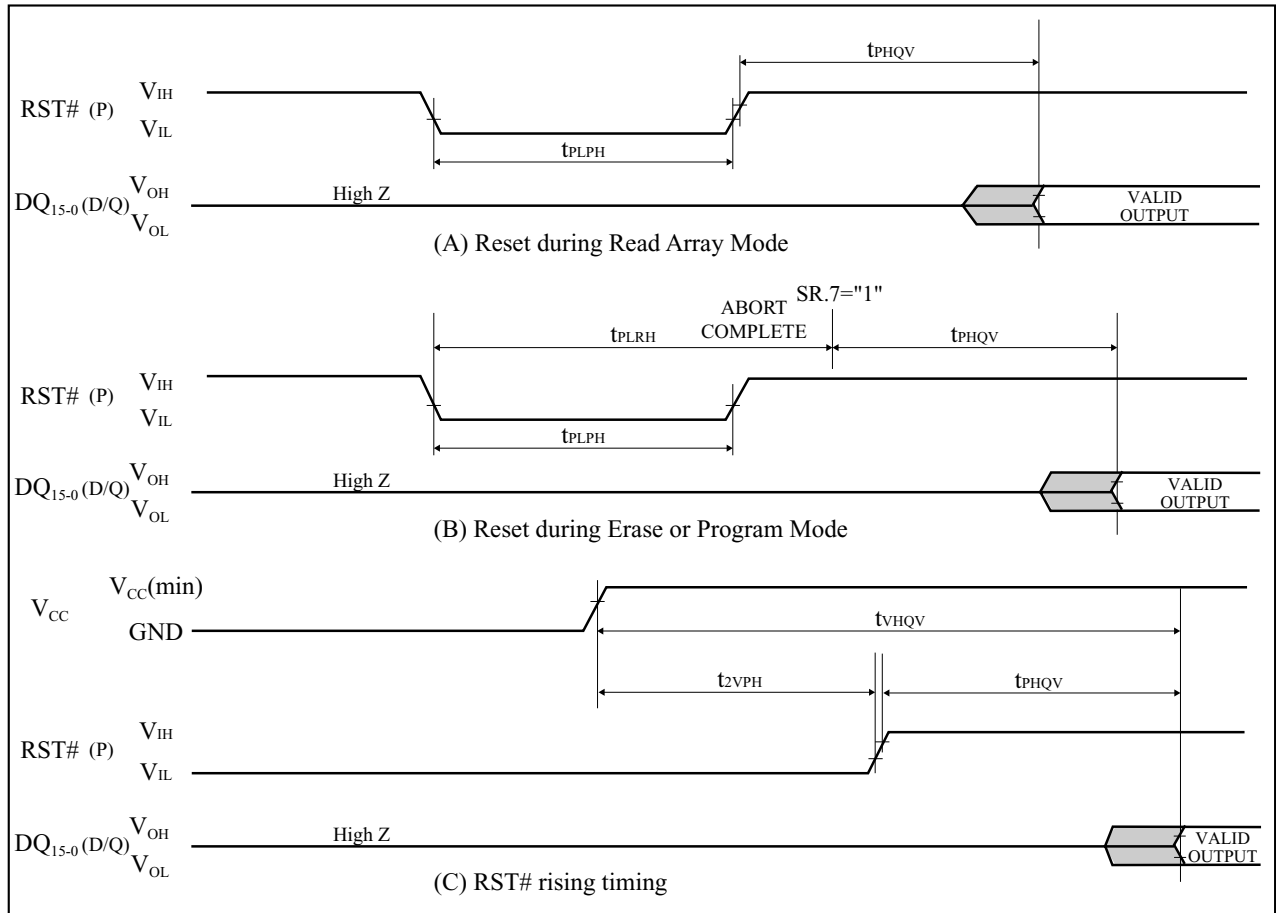

Figure 10. AC Waveform for Reset Operations

Reset AC Specifications ($V_{CC}=2.7V-3.6V$, $T_A=-40^{\circ}C$ to $+85^{\circ}C$)

Symbol	Parameter	Notes	Min.	Max.	Unit
t_{PLPH}	RST# Low to Reset during Read (RST# should be low during power-up.)	1, 2, 3	100		ns
t_{PLRH}	RST# Low to Reset during Erase or Program	1, 3, 4		22	μs
t_{2VPH}	V_{CC} 2.7V to RST# High	1, 3, 5	100		ns
t_{VHQV}	V_{CC} 2.7V to Output Delay	3		1	ms

NOTES:

1. A reset time, t_{PHQV} , is required from the later of SR.7 going "1" or RST# going high until outputs are valid. Refer to AC Characteristics - Read-Only Operations for t_{PHQV} .
2. t_{PLPH} is <100ns the device may still reset but this is not guaranteed.
3. Sampled, not 100% tested.
4. If RST# asserted while a block erase, full chip erase, (page buffer) program or OTP program operation is not executing, the reset will complete within 100ns.
5. When the device power-up, holding RST# low minimum 100ns is required after V_{CC} has been in predefined range and also has been in stable there.

1.2.7 Block Erase, Full Chip Erase, (Page Buffer) Program and OTP Program Performance⁽³⁾

$V_{CC}=2.7V-3.6V$, $T_A=-40^{\circ}C$ to $+85^{\circ}C$

Symbol	Parameter	Notes	Page Buffer Command is Used or not Used	$V_{PP}=V_{PPH1}$ (In System)			$V_{PP}=V_{PPH2}$ (In Manufacturing)			Unit
				Min.	Typ. ⁽¹⁾	Max. ⁽²⁾	Min.	Typ. ⁽¹⁾	Max. ⁽²⁾	
t_{WPB}	4K-Word Parameter Block Program Time	2	Not Used		0.05	0.3		0.04	0.12	s
		2	Used		0.03	0.12		0.02	0.06	s
t_{WMB}	32K-Word Main Block Program Time	2	Not Used		0.38	2.4		0.31	1.0	s
		2	Used		0.24	1.0		0.17	0.5	s
t_{WHQV1}/t_{EHQV1}	Word Program Time	2	Not Used		11	200		9	185	μs
		2	Used		7	100		5	90	μs
t_{WHOV1}/t_{EHOV1}	OTP Program Time	2	Not Used		36	400		27	185	μs
t_{WHQV2}/t_{EHQV2}	4K-Word Parameter Block Erase Time	2	-		0.3	4		0.2	4	s
t_{WHQV3}/t_{EHQV3}	32K-Word Main Block Erase Time	2	-		0.6	5		0.5	5	s
	Full Chip Erase Time	2			80	700				s
t_{WHRH1}/t_{EHRH1}	(Page Buffer) Program Suspend Latency Time to Read	4	-		5	10		5	10	μs
t_{WHRH2}/t_{EHRH2}	Block Erase Suspend Latency Time to Read	4	-		5	20		5	20	μs
t_{ERES}	Latency Time from Block Erase Resume Command to Block Erase Suspend Command	5	-		500			500		μs

NOTES:

1. Typical values measured at $V_{CC}=3.0V$, $V_{PP}=3.0V$ or $12V$, and $T_A=+25^{\circ}C$. Assumes corresponding lock bits are not set. Subject to change based on device characterization.
2. Excludes external system-level overhead.
3. Sampled, but not 100% tested.
4. A latency time is required from writing suspend command (WE# or CE# going high) until SR.7 going "1".
5. If the interval time from a Block Erase Resume command to a subsequent Block Erase Suspend command is shorter than t_{ERES} and its sequence is repeated, the block erase operation may not be finished.

2 Related Document Information⁽¹⁾

Document No.	Document Name
FUM00701	LH28F640BF series Appendix

NOTE:

1. International customers should contact their local SHARP or distribution sales offices.

onlinecomponents.com

A-1 RECOMMENDED OPERATING CONDITIONS

A-1.1 At Device Power-Up

AC timing illustrated in Figure A-1 is recommended for the supply voltages and the control signals at device power-up. If the timing in the figure is ignored, the device may not operate correctly.

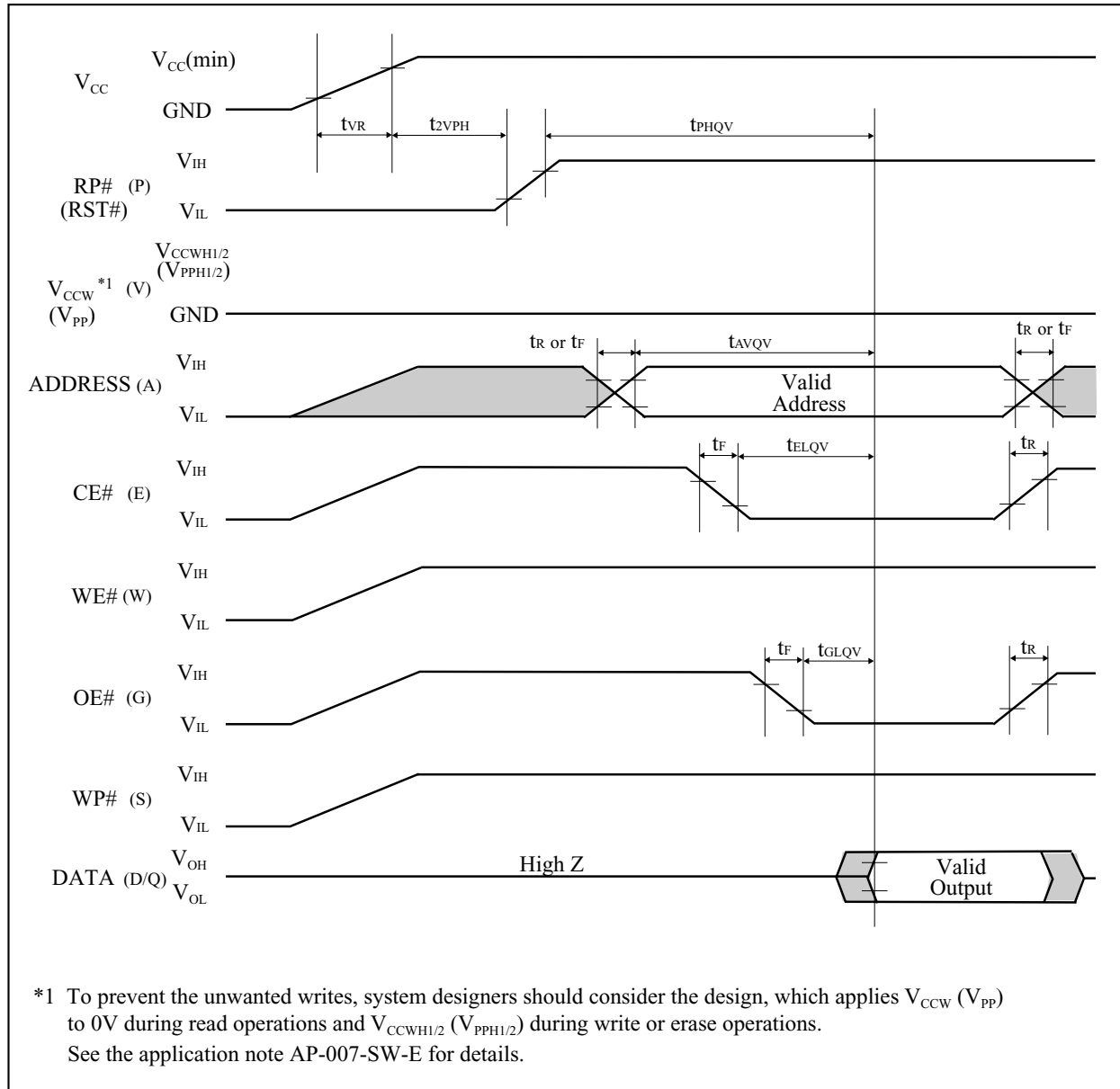

Figure A-1. AC Timing at Device Power-Up

For the AC specifications t_{VR} , t_r , t_f in the figure, refer to the next page. See the “ELECTRICAL SPECIFICATIONS” described in specifications for the supply voltage range, the operating temperature and the AC specifications not shown in the next page.

A-1.1.1 Rise and Fall Time

Symbol	Parameter	Notes	Min.	Max.	Unit
t_{VR}	V_{CC} Rise Time	1	0.5	30000	$\mu s/V$
t_R	Input Signal Rise Time	1, 2		1	$\mu s/V$
t_F	Input Signal Fall Time	1, 2		1	$\mu s/V$

NOTES:

1. Sampled, not 100% tested.
2. This specification is applied for not only the device power-up but also the normal operations.

onlinecomponents.com

A-1.2 Glitch Noises

Do not input the glitch noises which are below V_{IH} (Min.) or above V_{IL} (Max.) on address, data, reset, and control signals, as shown in Figure A-2 (b). The acceptable glitch noises are illustrated in Figure A-2 (a).

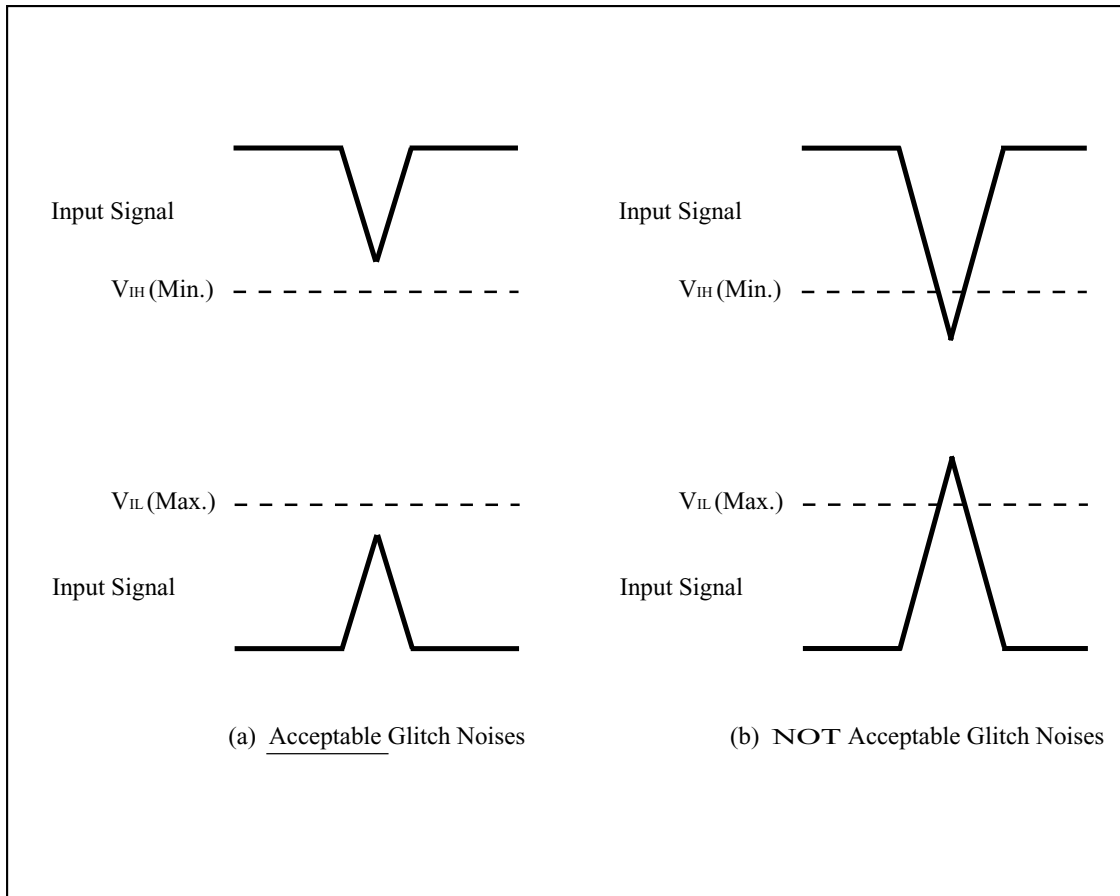

Figure A-2. Waveform for Glitch Noises

See the “DC CHARACTERISTICS” described in specifications for V_{IH} (Min.) and V_{IL} (Max.).

A-2 RELATED DOCUMENT INFORMATION⁽¹⁾

Document No.	Document Name
AP-001-SD-E	Flash Memory Family Software Drivers
AP-006-PT-E	Data Protection Method of SHARP Flash Memory
AP-007-SW-E	RP#, V _{pp} Electric Potential Switching Circuit

NOTE:

1. International customers should contact their local SHARP or distribution sales office.

onlinecomponents.com