

Low Voltage Stepper and Single/Dual DC Motor Driver

Features and Benefits

- 2.5 to 9 V operation
- Internal PWM current limit control
- Synchronous rectification for reduced power dissipation
- Peak current output flag
- Undervoltage lockout
- Low $R_{DS(on)}$ outputs
- Small package
- Brake mode for DC motors
- Sleep function
- Crossover-current protection
- Thermal shutdown

Package: 20-contact QFN (suffix ES)

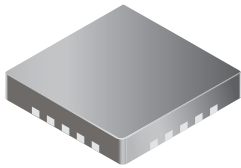

Approximate size

Description

Designed for pulse width modulated (PWM) control of low voltage stepper motors, and single and dual DC motors, the A3906 is capable of output currents up to 1 A per channel and operating voltages from 2.5 to 9 V.

The A3906 has an internal fixed off-time PWM timer that sets a peak current based on the selection of a current sense resistor. An overcurrent output flag is provided that notifies the user when the current in the motor winding reaches the peak current determined by the sense resistor. The fault output does not affect driver operation.

The A3906 is provided in a 20-contact, 4 mm × 4 mm, 0.75 mm nominal overall height QFN, with exposed pad for enhanced thermal dissipation. It is lead (Pb) free, with 100% matte tin leadframe plating.

Applications include the following:

- Digital still cameras (DSC)
- Cell phone cameras
- USB powered devices
- Battery powered devices

Typical Applications

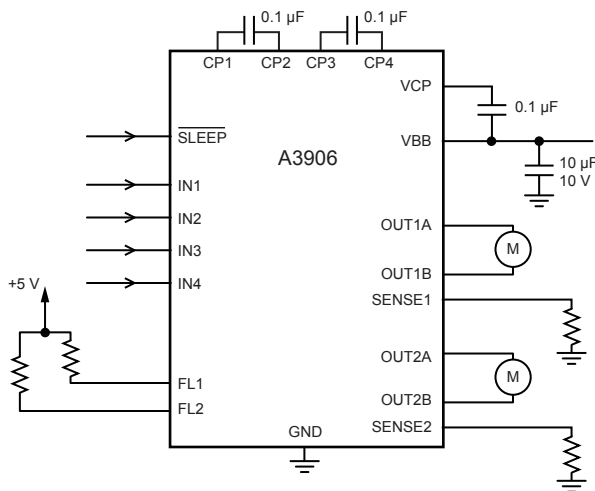

Dual DC motor application

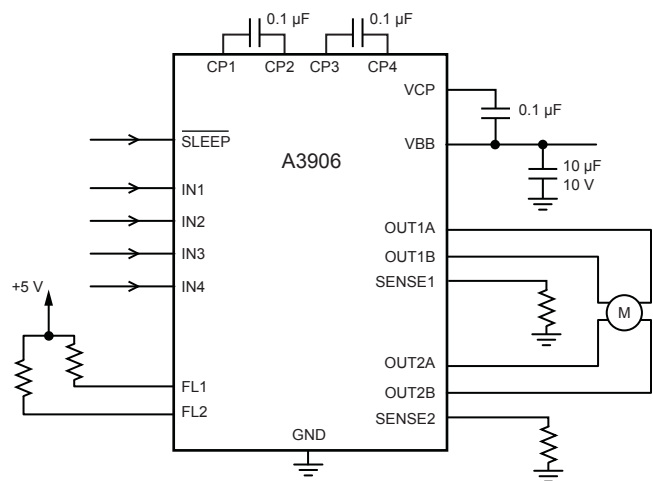

Stepper motor application

Selection Guide

Part Number	Packing	Package
A3906SESTR-T	1500 pieces per 7-in. reel	20-pin QFN with exposed thermal pad

Absolute Maximum Ratings

Characteristic	Symbol	Notes	Rating	Units	
Load Supply Voltage	V_{BB}		9.6	V	
Logic Input Voltage Range	V_{IN}		-0.3 to 7	V	
Sense Voltage	V_{SENSEX}	Continuous	0.5	V	
		Pulsed, $t_w < 1 \mu s$	1	V	
Output Current	I_{OUT}	May be limited by duty cycle, ambient temperature, and heat sinking. Under any set of conditions, do not exceed the specified current rating or a junction temperature of 150°C.	Continuous	1	A
			Peak, DC < 30%	1.5	A
Output Current in Paralleled Operation	$I_{OUT(par)}$		Continuous	2	A
			Peak, DC < 30%	2.5	A
Operating Temperature Range	T_A	Range S	-20 to 85	°C	
Junction Temperature	$T_{J(max)}$		150	°C	
Storage Temperature Range	T_{stg}		-40 to 150	°C	

Thermal Characteristics may require derating at maximum conditions, see application information

Characteristic	Symbol	Test Conditions*	Value	Units
Package Thermal Resistance	$R_{\theta JA}$	4-layer PCB based on JEDEC standard	37	°C/W

*Additional thermal information available on the Allegro website.

Pin-out Diagram

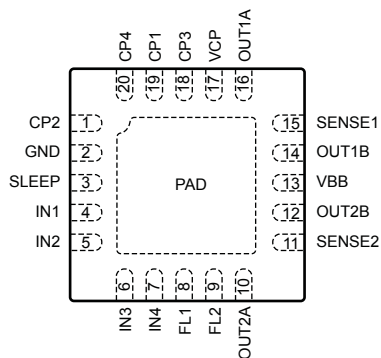

Terminal List Table

Number	Name	Function
1	CP2	Charge pump capacitor terminal 2
2	GND	Ground
3	SLEEP	Sleep logic input, active low
4	IN1	Control input
5	IN2	Control input
6	IN3	Control input
7	IN4	Control input
8	FL1	Current limit flag, bridge 1
9	FL2	Current limit flag bridge 2
10	OUT2A	DMOS full-bridge 2, output A
11	SENSE2	Current sense resistor terminal, bridge 2
12	OUT2B	DMOS full-bridge 2, output B
13	VBB	Supply Voltage
14	OUT1B	DMOS full-bridge 1, output B
15	SENSE1	Current sense resistor terminal, bridge 1
16	OUT1A	DMOS full-bridge 1, output A
17	VCP	Reservoir capacitor terminal
18	CP3	Charge pump capacitor terminal 3
19	CP1	Charge pump capacitor terminal 1
20	CP4	Charge pump capacitor terminal 4
-	PAD	Exposed pad for enhanced thermal performance

Functional Block Diagram

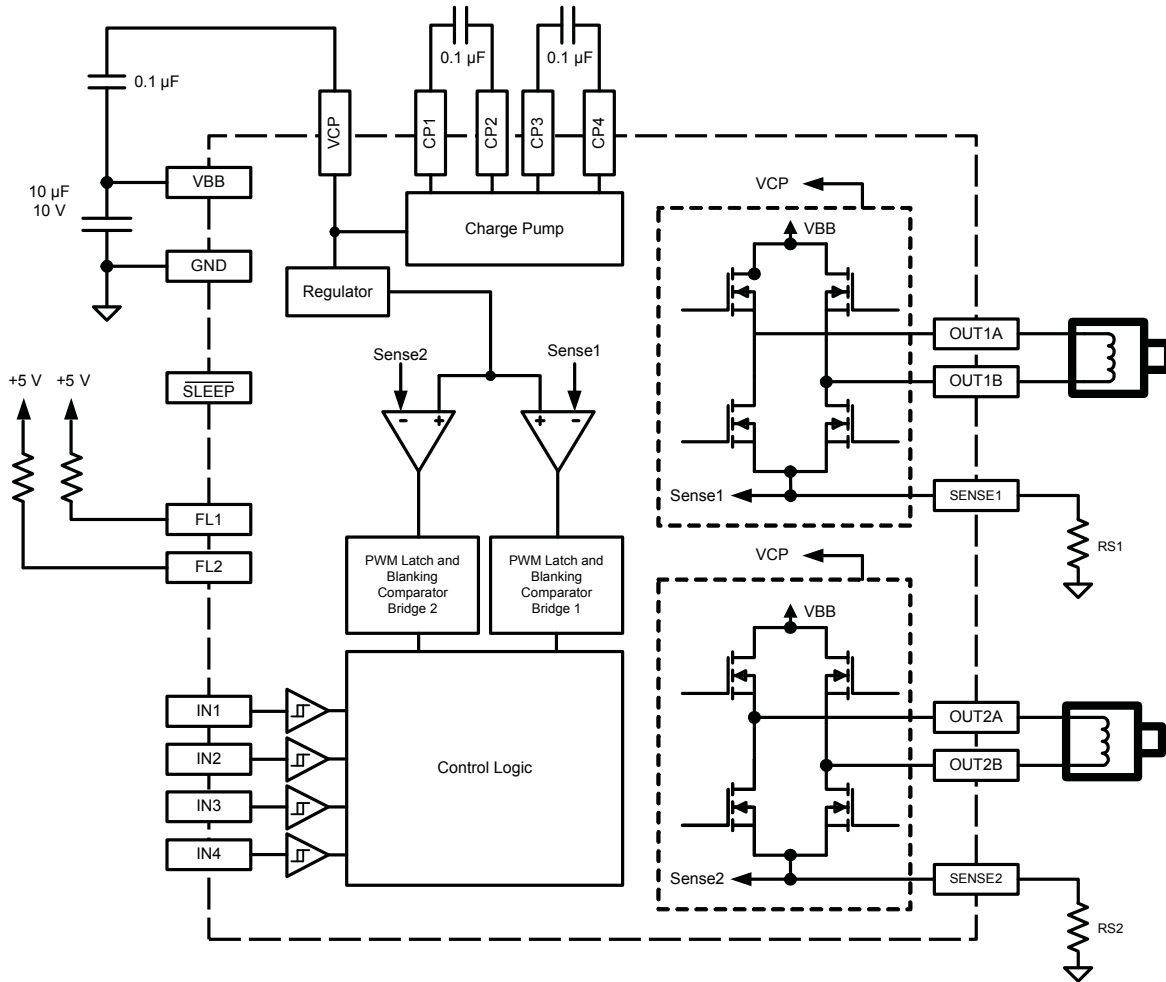

ELECTRICAL CHARACTERISTICS^{1,2} valid at $T_A = 25^\circ\text{C}$ and $V_{BB} = 2.5$ to 9 V, unless otherwise noted

Characteristics	Symbol	Test Conditions	Min.	Typ.	Max.	Units
Operating Voltage Range	V_{BB}		2.5	–	9	V
VBB Supply Current	I_{BB}	$I_{OUT} = 0$ mA, PWM = 50 kHz, Duty Cycle = 50%	–	5	–	mA
		$I_{OUT} = 0$ mA, outputs disabled, $V_{BB} = 9.6$ V	–	3	–	mA
		Sleep mode, $V_{IN} < 0.4$ V	–	150	500	nA
Output Resistance	$R_{DS(on)}$	Source driver, $I_{OUT} = 400$ mA, $V_{BB} = 3$ V, $T_J = 25^\circ\text{C}$	–	0.52	0.68	Ω
		Source driver, $I_{OUT} = 400$ mA, $V_{BB} = 3$ V, $T_J = 85^\circ\text{C}$	–	0.710	–	Ω
		Sink driver, $I_{OUT} = 400$ mA, $V_{BB} = 3$ V, $T_J = 25^\circ\text{C}$	–	0.52	0.68	Ω
		Sink driver, $I_{OUT} = 400$ mA, $V_{BB} = 3$ V, $T_J = 85^\circ\text{C}$	–	0.710	–	Ω
Clamp Diode Voltage	V_f	$I = 400$ mA	–	–	1	V
Output Leakage Current	I_{DSS}	Outputs, $V_{OUT} = 9$ V	–20	–	20	μA
Control Logic						
Logic Input Voltage	$V_{IN(1)}$		2.0	–	5.5	V
	$V_{IN(0)}$		–	–	0.8	V
Logic Input Current	$I_{IN(1)}$	$V_{IN} = 5.5$ V	–	<100	500	nA
	$I_{IN(0)}$	$V_{IN} = 0.8$ V	–	<–100	–500	nA
Input Hysteresis	V_{INhys}		–	150	–	mV
$\overline{\text{SLEEP}}$ Input	$V_{\text{SLEEP}(0)}$		–	–	0.4	V
	$V_{\text{SLEEP}(1)}$		2	–	–	V
Fault Output	V_{FLX}	Flag asserted, $I_{FLX} = 1$ mA	–	–	200	mV
Fault Output Leakage Current	I_{FLX}	$V_{FLX} = 5$ V	–	–	1	μA
Fault Output Timer	t_{FLX}	Reset of PWM latch	–	300	–	μs
Blank Time	t_{BLANK}		2.1	3	3.9	μs
Fixed Off-Time	t_{OFF}		–	30	–	μs
Propagation Delay Time	$t_{pd(on)}$	Input high to source on, input low to source off	100	235	350	ns
	$t_{pd(off)}$	Input low to sink off, input high to sink on	50	100	200	ns
Protection Circuitry						
Crossover Delay	t_{COD}		200	425	650	ns
VBB Undervoltage Lockout Threshold	V_{BBUVLO}	V_{BB} rising	2.2	2.31	2.45	V
VBB Undervoltage Lockout Hysteresis	$V_{BBUVHYS}$		200	300	400	mV
Thermal Shutdown Temperature	T_{JTSD}		–	165	–	$^\circ\text{C}$
Thermal Shutdown Hysteresis	$T_{JTSDHYS}$		–	15	–	$^\circ\text{C}$

¹For input and output current specifications, negative current is defined as coming out of (sourcing) the specified device pin.

²Specifications over the operating temperature range are assured by design and characterization.

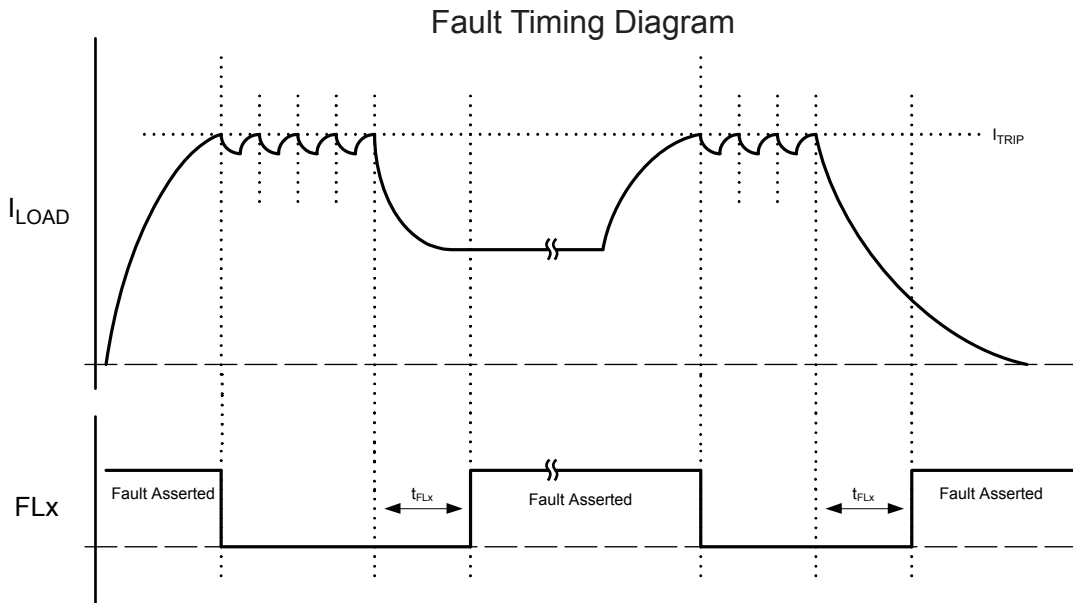

NOTE: Timer resets after each reset of the PWM latch.

Control Logic

DC Motor Operation

IN1	IN2	IN3	IN4	OUT1A	OUT1B	OUT2A	OUT2B	Function	
0	0	0	0	Off	Off	Off	Off	Disabled	
1	0	1	0	High	Low	High	Low	Forward	
0	1	0	1	Low	High	Low	High	Reverse	
1	1	1	1	Low	Low	Low	Low	Brake	

Stepper Motor Operation

IN1	IN2	IN3	IN4	OUT1A	OUT1B	OUT2A	OUT2B	Function	
0	0	0	0	Off	Off	Off	Off	Disabled	Disabled
1	0	1	0	High	Low	High	Low	Full Step 1	½ Step 1
0	0	1	0	Off	Off	High	Low	–	½ Step 2
0	1	1	0	Low	High	High	Low	Full Step 2	½ Step 3
0	1	0	0	Low	High	Off	Off	–	½ Step 4
0	1	0	1	Low	High	Low	High	Full Step 3	½ Step 5
0	0	0	1	Off	Off	Low	High	–	½ Step 6
1	0	0	1	High	Low	Low	High	Full Step 4	½ Step 7
1	0	0	0	High	Low	Off	Off	–	½ Step 8

Functional Description

Device Operation The A3906 is a dual full-bridge low voltage motor driver capable of operating one stepper motor, two DC motors, or one high current DC motor. MOSFET output stages substantially reduce the voltage drop and the power dissipation of the outputs of the A3906, compared to typical drivers with bipolar transistors.

Output current can be regulated by pulse width modulating (PWM) the inputs. In addition supporting external PWM of the driver, the A3906 limits the peak current by internally PWMing the source driver when the current in the winding exceeds the peak current, which is determined by a sense resistor. A fault output notifies the user that peak current was reached. If internal current limiting is not needed, the sense pin should be shorted to ground.

Internal circuit protection includes thermal shutdown with hysteresis, undervoltage lockout, internal clamp diodes, and crossover current protection.

The A3906 is designed for portable applications, providing a power-off low current sleep mode and an operating voltage of 2.5 to 9 V.

External PWM Output current regulation can be achieved by pulse width modulating the inputs. Slow decay mode is selected by holding one input high while PWMing the other input. Holding one input low and PWMing the other input results in fast decay. Refer to the Applications Information section for further information.

Blanking This function blanks the output of the current sense comparator when the outputs are switched. The comparator output is blanked to prevent false overcurrent detections due to reverse recovery currents of the clamp diodes or to switching transients related to the capacitance of the load. The blank time, t_{BLANK} , is approximately 3 μs .

Sleep Mode An active-low control input used to minimize power consumption when the A3906 is not in use. This disables much of the internal circuitry including the output drivers, internal regulator, and charge pump. A logic high allows normal operation. When coming out of sleep mode, wait 1.5 ms before issuing a command, to allow the internal regulator and charge pump to stabilize.

Enable When all logic inputs are pulled to logic low, the outputs of the bridges are disabled. The charge pump and internal circuitry continue to run when the outputs are disabled.

Charge Pump (CP1, CP2, CP3, and CP4) When supply voltages are lower than 3.5 V, the two-stage charge pump triples the input voltage to a maximum of 7 V above the supply. The charge

pump is used to create a supply voltage greater than V_{BB} , to drive the source-side DMOS gates. For pumping purposes, a 0.1 μF ceramic capacitor should be connected between CP1 and CP2, and between CP3 and CP4. A 0.1 μF ceramic capacitor is required between VCP and VBB, to act as a reservoir to operate the high-side DMOS devices.

Thermal Shutdown The A3906 will disable the outputs if the junction temperature reaches 165°C. When the junction temperature drops 15°C, the outputs will be enabled.

Brake Mode When driving DC motors, the A3906 goes into brake mode (turns on both sink drivers) when both of its inputs are high (IN1 and IN2, or IN3 and IN4). There is no protection during braking, so care must be taken to ensure that the peak current during braking does not exceed the absolute maximum current.

Internal PWM Current Control Each full-bridge is controlled by a fixed off-time PWM current control circuit that limits the load current to a desired value, I_{TRIP} . Initially, a diagonal pair of source and sink DMOS outputs are enabled and current flows through the motor winding and the current sense resistor, RS_x . When the voltage across RS_x equals the internal reference voltage, the current sense comparator resets the PWM latch, which turns off the source driver.

The maximum value of current limiting, $I_{\text{TRIP}(\text{max})}$, is set by the selection of the sense resistor, RS_x , and is approximated by a transconductance function:

$$I_{\text{TRIP}(\text{max})} = 0.2 / R_{\text{S}} .$$

It is critical to ensure the maximum rating on SENSE x pins (0.5 V) is not exceeded.

Synchronous Rectification When a PWM off-cycle is triggered by an internal fixed off-time cycle, load current recirculates in slow decay SR mode. During slow decay, current recirculates through the sink-side FET and the sink-side body diode. The SR feature enables the sink-side FET, effectively shorting out the body diode. The sink driver is not enabled until the source driver is turned off and the crossover delay has expired. This feature helps lower the voltage drop during current recirculation, lowering power dissipation in the bridge.

Overcurrent Output Flag When the peak current (set by the external resistor) is reached, the fault pin, FL x , is pulled low. When a reset of the PWM latch occurs, the fault timer begins. At each PWM latch reset, the timer is reset to zero. After approximately 300 μs , if no peak current event was triggered, the timer expires and the fault is released. This ensures that during PWM current limiting, the fault pin remains in a fault state.

Applications Information

External PWM If external PWM is used, the internal current control can either be disabled by shorting the SENSEx pin to ground, or it can be used to limit the peak current to a value under the stall current to prevent motor heating. External PWM IN1 control is shown in the upper figure.

Stepper Motor Control The A3906 also can be used to control a bipolar stepper motor. The control logic for stepper motor control is shown in the lower figure. The driver is capable of operating in full- and half-step modes.

PWM current control in fast and slow decay modes

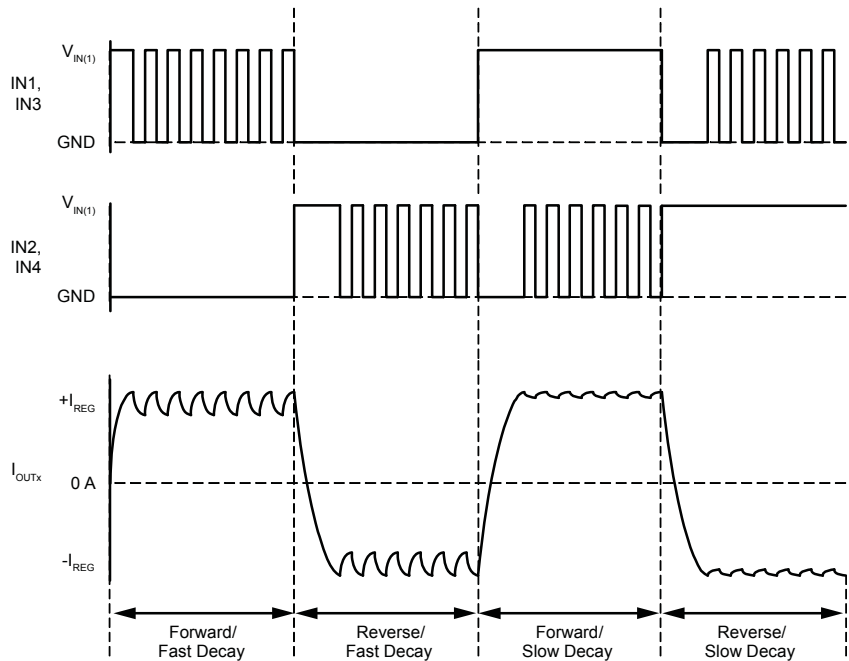

Stepper motor control in full- and half-step modes

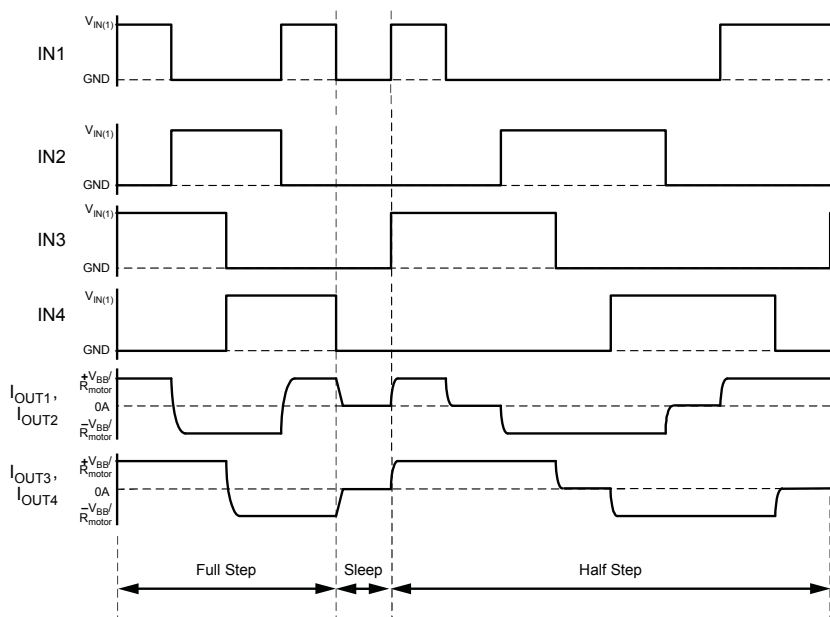

Parallel Operation The A3906 can be paralleled for applications that require higher output currents. In paralleled mode the driver can source 2 A continuous. The A3906 has two completely independent bridges with separate overcurrent latches. This allows the device to supply two separate loads, and as a result, when paralleled it is imperative that the internal current control is disabled by shorting the sense pins to ground.

Because the overcurrent trip threshold is internally fixed at 0.2 V, the trace resistance must be kept small so the internal current latch is not triggered prematurely. With acceptable margin, the voltage drop across the trace resistance should be under 0.1 V. At a peak current of 2.5 A, the trace resistance should be kept below 40 mΩ to prevent false tripping of the overcurrent latch.

Each bridge has some variation in propagation delay. During this time it is possible that one bridge will have to support the full

load current for a very short period of time. Propagation delays are characterized and guard banded to protect the driver from damage during these events.

Layout The printed circuit board should use a heavy ground-plane. For optimum electrical and thermal performance, the A3906 must be soldered directly onto the board. On the underside of the A3906 package is an exposed pad, which provides a path for enhanced thermal dissipation. The thermal pad should be soldered directly to an exposed surface on the PCB. Thermal vias are used to transfer heat to other layers of the PCB.

Grounding In order to minimize the effects of ground bounce and offset issues, it is important to have a low impedance single-point ground, known as a *star ground*, located very close to the device. By making the connection between the exposed thermal pad and the ground plane directly under the A3906, that area

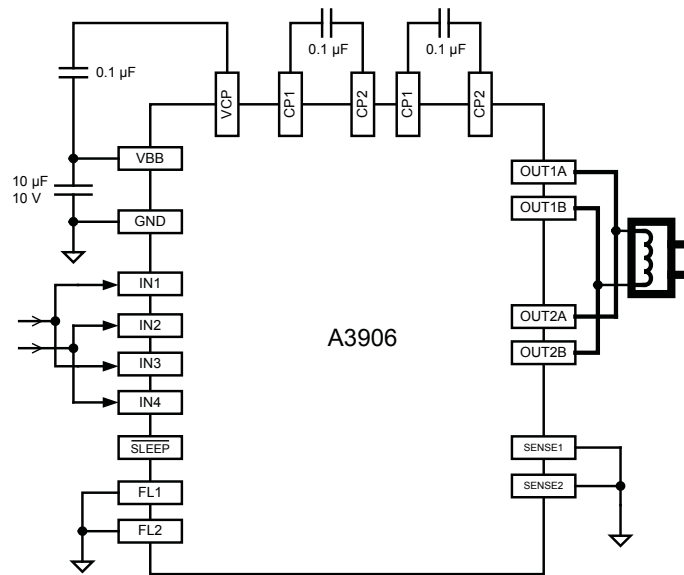

DC Motor Operation (Parallel Bridge)

IN1/IN3	IN2/IN4	OUT1A/2A	OUT1B/2B	Function
0	0	OFF	OFF	Disabled
1	0	H	L	FOR
0	1	L	H	REV
1	1	L	L	BRAKE

becomes an ideal location for a star ground point. A low impedance ground will prevent ground bounce during high current operation and ensure that the supply voltage remains stable at the input terminal. The recommended PCB layout shown in the diagram below, illustrates how to create a star ground under the device, to serve both as low impedance ground point and thermal path.

The two input capacitors should be placed in parallel, and as close to the device supply pins as possible. The ceramic capacitor should be closer to the pins than the bulk capacitor. This is necessary because the ceramic capacitor will be responsible for delivering the high frequency current components.

Sense Pins The sense resistors, RS_x , should have a very low impedance path to ground, because they must carry a large current while supporting very accurate voltage measurements by the current sense comparators. Long ground traces will cause additional voltage drops, adversely affecting the ability of the comparators to accurately measure the current in the windings. As shown in the layout below, the $SENSE_x$ pins have very short traces to the RS_x resistors and very thick, low impedance traces directly to the star ground underneath the device. If possible, there should be no other components on the sense circuits.

Note: When selecting a value for the sense resistors, be sure not to exceed the maximum voltage on the $SENSE_x$ pins of ± 500 mV.

PCB Layout

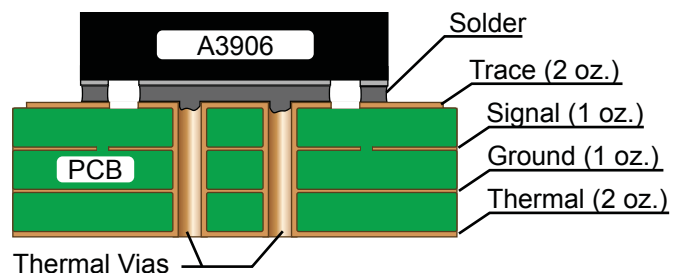
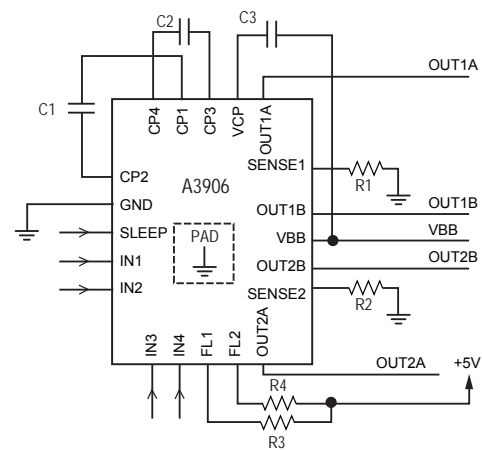
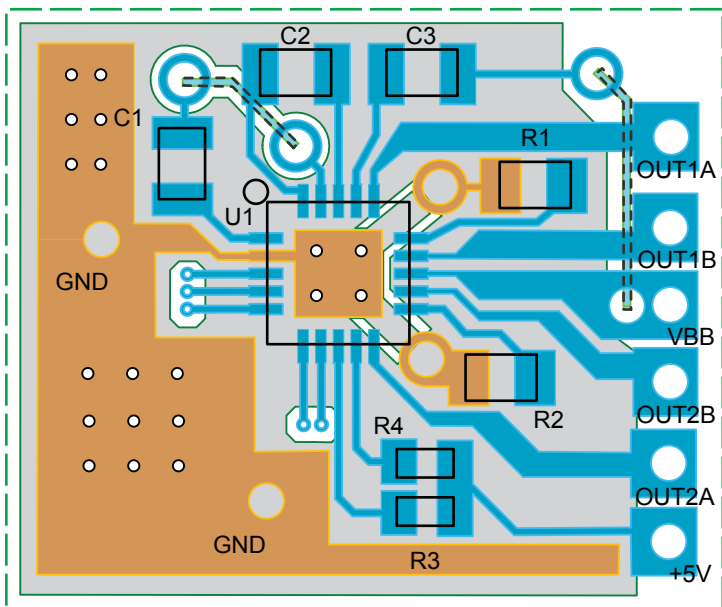

ES Package, 20-Contact QFN with Exposed Thermal Pad

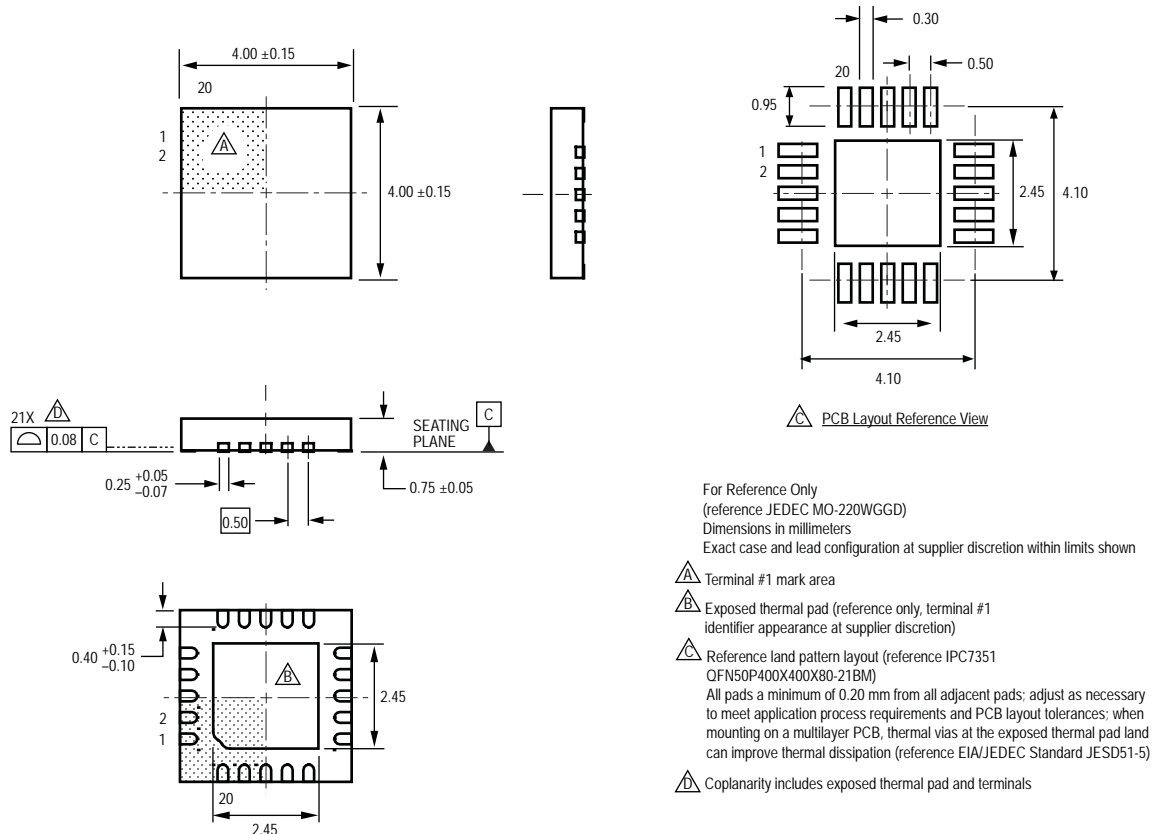

Copyright ©2008, Allegro MicroSystems, Inc.

The products described here are manufactured under one or more U.S. patents or U.S. patents pending.

Allegro MicroSystems, Inc. reserves the right to make, from time to time, such departures from the detail specifications as may be required to permit improvements in the performance, reliability, or manufacturability of its products. Before placing an order, the user is cautioned to verify that the information being relied upon is current.

Allegro's products are not to be used in life support devices or systems, if a failure of an Allegro product can reasonably be expected to cause the failure of that life support device or system, or to affect the safety or effectiveness of that device or system.

The information included herein is believed to be accurate and reliable. However, Allegro MicroSystems, Inc. assumes no responsibility for its use; nor for any infringement of patents or other rights of third parties which may result from its use.

For the latest version of this document, visit our website:

www.allegromicro.com



Allegro MicroSystems, Inc.
 115 Northeast Cutoff
 Worcester, Massachusetts 01615-0036 U.S.A.
 1.508.853.5000; www.allegromicro.com