

General Description

The MIC4426/4427/4428 family are highly-reliable dual low-side MOSFET drivers fabricated on a BiCMOS/DMOS process for low power consumption and high efficiency. These drivers translate TTL or CMOS input logic levels to output voltage levels that swing within 25mV of the positive supply or ground. Comparable bipolar devices are capable of swinging only to within 1V of the supply. The MIC4426/7/8 is available in three configurations: dual inverting, dual noninverting, and one inverting plus one noninverting output.

The MIC4426/4427/4428 are pin-compatible replacements for the MIC426/427/428 and MIC1426/1427/1428 with improved electrical performance and rugged design (Refer to the Device Replacement lists on the following page). They can withstand up to 500mA of reverse current (either polarity) without latching and up to 5V noise spikes (either polarity) on ground pins.

Primarily intended for driving power MOSFETs, MIC4426/7/8 drivers are suitable for driving other loads (capacitive, resistive, or inductive) which require low-impedance, high peak current, and fast switching time. Other applications include driving heavily loaded clock lines, coaxial cables, or piezoelectric transducers. The only load limitation is that total driver power dissipation must not exceed the limits of the package.

Note See MIC4126/4127/4128 for high power and narrow pulse applications.

Features

- Bipolar/CMOS/DMOS construction
- Latch-up protection to >500mA reverse current
- 1.5A-peak output current
- 4.5V to 18V operating range
- Low quiescent supply current
 - 4mA at logic 1 input
 - 400µA at logic 0 input
- Switches 1000pF in 25ns
- Matched rise and fall times
- 7Ω output impedance
- <40ns typical delay
- Logic-input threshold independent of supply voltage
- Logic-input protection to -5V
- 6pF typical equivalent input capacitance
- 25mV max. output offset from supply or ground
- Replaces MIC426/427/428 and MIC1426/1427/1428
- Dual inverting, dual noninverting, and inverting/noninverting configurations
- ESD protection

Applications

- MOSFET driver
- Clock line driver
- Coax cable driver
- Piezoelectric transducer driver

Functional Diagram

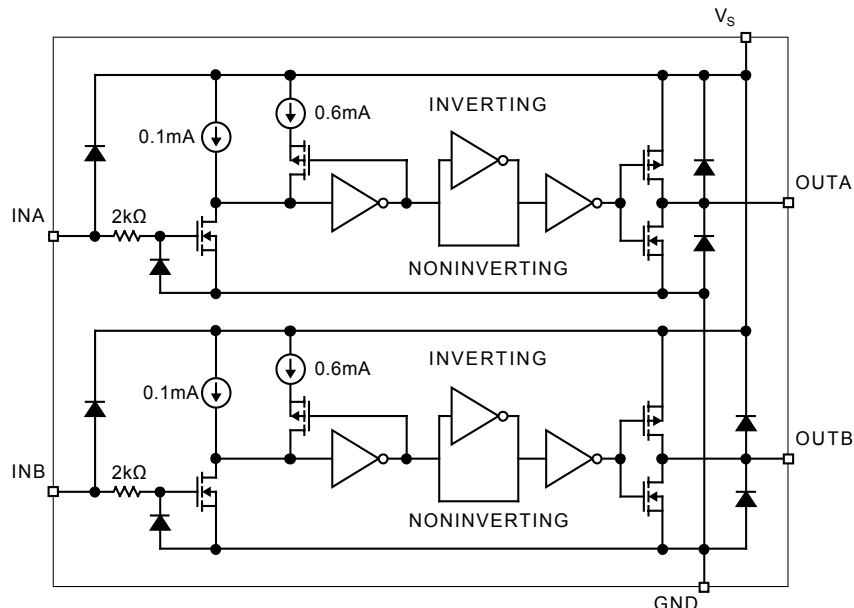

Ordering Information

| Part Number | | Temperature Range | Package | Configuration |
|-------------|-----------------|-------------------|------------|---------------------------|
| Standard | Pb-Free | | | |
| MIC4426AM* | Contact Factory | -55°C to +125°C | 8-Pin SOIC | Dual Inverting |
| MIC4426BM | MIC4426YM | -40°C to +85°C | 8-Pin SOIC | Dual Inverting |
| MIC4426CM | MIC4426ZM | -0°C to +70°C | 8-Pin SOIC | Dual Inverting |
| MIC4426BMM | MIC4426YMM | -40°C to +85°C | 8-Pin MSOP | Dual Inverting |
| MIC4426BN | MIC4426YN | -40°C to +85°C | 8-Pin PDIP | Dual Inverting |
| MIC4426CN | MIC4426ZN | -0°C to +70°C | 8-Pin PDIP | Dual Inverting |
| MIC4427AM* | Contact Factory | -55°C to +125°C | 8-Pin SOIC | Dual Non-Inverting |
| MIC4427BM | MIC4427YM | -40°C to +85°C | 8-Pin SOIC | Dual Non-Inverting |
| MIC4427CM | MIC4427ZM | -0°C to +70°C | 8-Pin SOIC | Dual Non-Inverting |
| MIC4427BMM | MIC4427YMM | -40°C to +85°C | 8-Pin MSOP | Dual Non-Inverting |
| MIC4427BN | MIC4427YN | -40°C to +85°C | 8-Pin PDIP | Dual Non-Inverting |
| MIC4427CN | MIC4427ZN | -0°C to +70°C | 8-Pin PDIP | Dual Non-Inverting |
| MIC4428AM* | Contact Factory | -55°C to +125°C | 8-Pin SOIC | Inverting + Non-Inverting |
| MIC4428BM | MIC4428YM | -40°C TO +85°C | 8-Pin SOIC | Inverting + Non-Inverting |
| MIC4428CM | MIC4428ZM | -0°C to +70°C | 8-Pin SOIC | Inverting + Non-Inverting |
| MIC4428BMM | MIC4428YMM | -40°C to +85°C | 8-Pin MSOP | Inverting + Non-Inverting |
| MIC4428BN | MIC4428YN | -40°C to +85°C | 8-Pin PDIP | Inverting + Non-Inverting |
| MIC4428CN | MIC4428ZN | -0°C to +70°C | 8-Pin PDIP | Inverting + Non-Inverting |

*Special order, contact factory.

MIC426/427/428 Device Replacement

| Discontinued Number | Replacement |
|---------------------|-------------|
| MIC426CM | MIC4426BM |
| MIC426BM | MIC4426BM |
| MIC426CN | MIC4426BN |
| MIC426BN | MIC4426BN |
| MIC427CM | MIC4427BM |
| MIC427BM | MIC4427BM |
| MIC427CN | MIC4427BN |
| MIC427BN | MIC4427BN |
| MIC428CM | MIC4428BM |
| MIC428BM | MIC4428BM |
| MIC428CN | MIC4428BN |
| MIC428BN | MIC4428BN |

MIC1426/1427/1428 Device Replacement

| Discontinued Number | Replacement |
|---------------------|-------------|
| MIC1426CM | MIC4426BM |
| MIC1426BM | MIC4426BM |
| MIC1426CN | MIC4426BN |
| MIC1426BN | MIC4426BN |
| MIC1427CM | MIC4427BM |
| MIC1427BM | MIC4427BM |
| MIC1427CN | MIC4427BN |
| MIC1427BN | MIC4427BN |
| MIC1428CM | MIC4428BM |
| MIC1428BM | MIC4428BM |
| MIC1428CN | MIC4428BN |
| MIC1428BN | MIC4428BN |

Pin Configuration

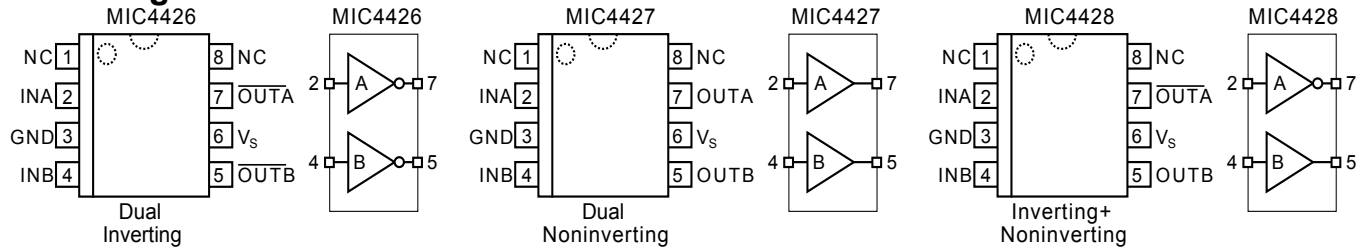

Pin Description

| Pin Number | Pin Name | Pin Function |
|------------|----------------|---|
| 1, 8 | NC | not internally connected |
| 2 | INA | Control Input A: TTL/CMOS compatible logic input. |
| 3 | GND | Ground |
| 4 | INB | Control Input B: TTL/CMOS compatible logic input. |
| 5 | OUTB | Output B: CMOS totem-pole output. |
| 6 | V _S | Supply Input: +4.5V to +18V |
| 7 | OUTA | Output A: CMOS totem-pole output. |

Absolute Maximum Ratings⁽¹⁾

| | |
|-------------------------------------|--------------------------|
| Supply Voltage (V_S)..... | +22V |
| Input Voltage (V_{IN})..... | $V_S + 0.3V$ to GND – 5V |
| Junction Temperature (T_J)..... | 150°C |
| Storage Temperature..... | –65°C to +150°C |
| Lead Temperature (10 sec.)..... | 300°C |
| ESD Rating ⁽³⁾ | |

Operating Ratings⁽²⁾

| | |
|-------------------------------|-----------------|
| Supply Voltage (V_S)..... | +4.5V to +18V |
| Temperature Range (T_A) | |
| (A)..... | –55°C to +125°C |
| (B)..... | –40°C to +85°C |
| Package Thermal Resistance | |
| PDIP θ_{JA} | 130°C/W |
| PDIP θ_{JC} | 42°C/W |
| SOIC θ_{JA} | 120°C/W |
| SOIC θ_{JC} | 75°C/W |
| MSOP θ_{JC} | 250°C/W |

Electrical Characteristics⁽⁴⁾

4.5V $\leq V_S \leq 18V$; $T_A = 25^\circ C$, **bold** values indicate full specified temperature range; unless noted.

| Symbol | Parameter | Condition | Min | Typ | Max | Units |
|-----------------------|-----------------------|-----------------------------|-------------------|---------------------|-------------------|----------------------|
| Input | | | | | | |
| V_{IH} | Logic 1 Input Voltage | | 2.4 2.4 | 1.4 1.5 | | V V |
| V_{IL} | Logic 0 Input Voltage | | | 1.1 1.0 | 0.8 0.8 | V V |
| I_{IN} | Input Current | $0 \leq V_{IN} \leq V_S$ | -1 | | 1 | μA |
| Output | | | | | | |
| V_{OH} | High Output Voltage | | $V_S - 0.025$ | | | V |
| V_{OL} | Low Output Voltage | | | | 0.025 | V |
| R_O | Output Resistance | $I_{OUT} = 10mA, V_S = 18V$ | | 6 8 | 10 12 | Ω Ω |
| I_{PK} | Peak Output Current | | | 1.5 | | A |
| I | Latch-Up Protection | withstand reverse current | >500 | | | mA |
| Switching Time | | | | | | |
| t_R | Rise Time | test Figure 1 | | 18 20 | 30 40 | ns ns |
| t_F | Fall Time | test Figure 1 | | 15 29 | 20 40 | ns ns |
| t_{D1} | Delay Time | test Figure 1 | | 17 19 | 30 40 | ns ns |
| t_{D2} | Delay Time | test Figure 1 | | 23 27 | 50 60 | ns ns |
| t_{PW} | Pulse Width | test Figure 1 | 400 | | | ns |
| Power Supply | | | | | | |
| I_S | Power Supply Current | $V_{INA} = V_{INB} = 3.0V$ | | 1.4 1.5 | 4.5 8 | mA mA |
| I_S | Power Supply Current | $V_{INA} = V_{INB} = 0.0V$ | | 0.18 0.19 | 0.4 0.6 | mA mA |

Notes:

1. Exceeding the absolute maximum rating may damage the device.
2. The device is not guaranteed to function outside its operating rating.
3. Devices are ESD sensitive. Handling precautions recommended.
4. Specification for packaged product only.

Test Circuits



Figure 1a. Inverting Configuration



Figure 2a. Noninverting Configuration

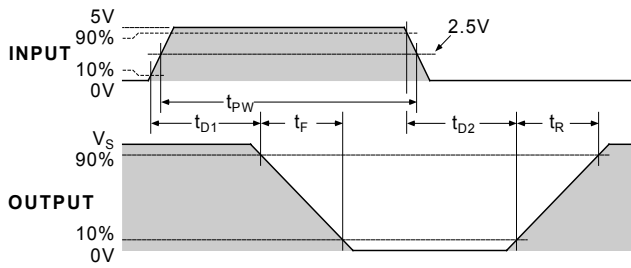

Figure 1b. Inverting Timing

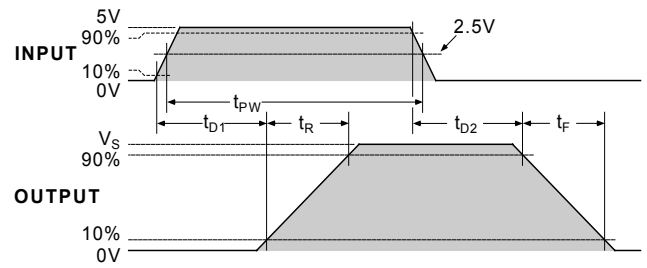

Figure 2b. Noninverting Timing

Electrical Characteristics

Rise and Fall Time vs. Supply Voltage



Delay Time vs. Supply Voltage

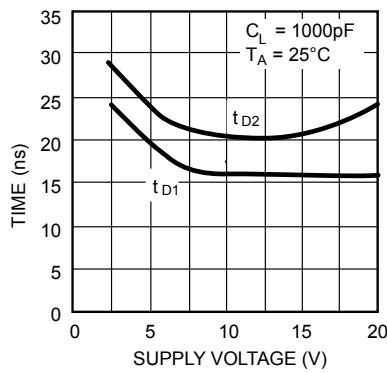

Rise and Fall Time vs. Temperature



Delay Time vs. Temperature

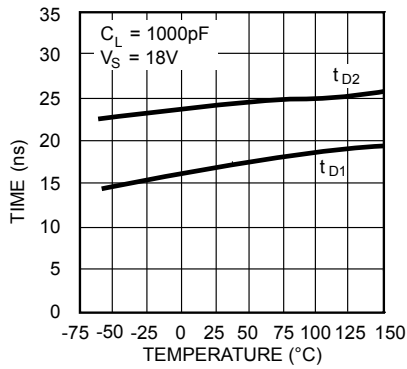

Supply Current vs. Capacitive Load

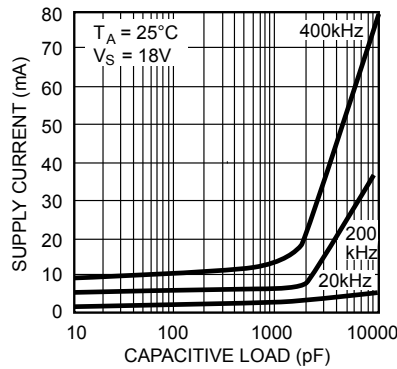

Rise and Fall Time vs. Capacitive Load

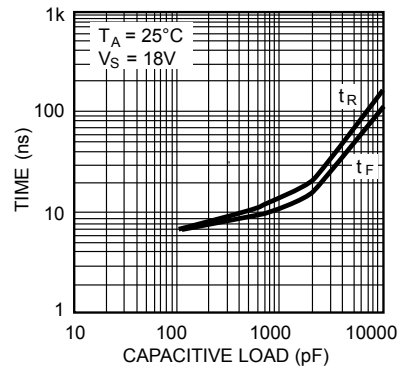

Supply Current vs. Frequency



High Output vs. Current

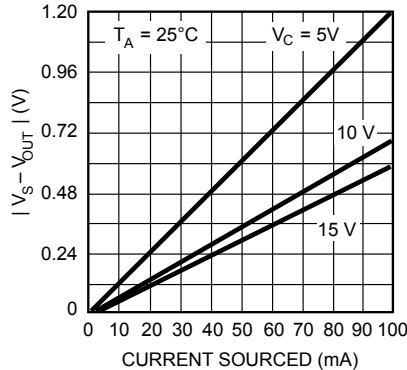

Low Output vs. Current



Quiescent Power Supply Current vs. Supply Voltage

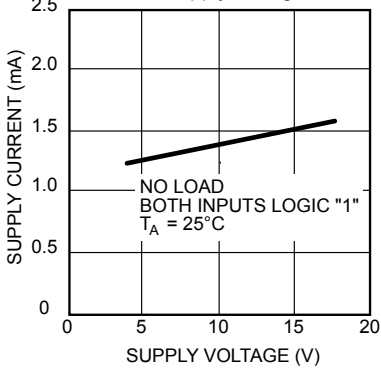

Quiescent Power Supply Current vs. Supply Voltage

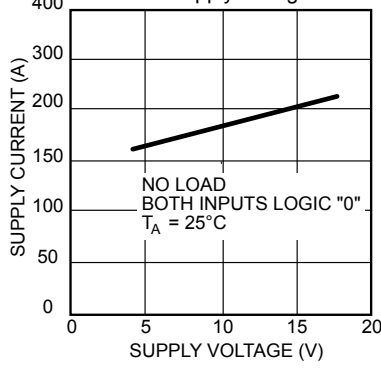

Package Power Dissipation



Applications Information

Supply Bypassing

Large currents are required to charge and discharge large capacitive loads quickly. For example, changing a 1000pF load by 16V in 25ns requires 0.8A from the supply input.

To guarantee low supply impedance over a wide frequency range, parallel capacitors are recommended for power supply bypassing. Low-inductance ceramic MLC capacitors with short lead lengths (< 0.5") should be used. A 1.0µF film capacitor in parallel with one or two 0.1µF ceramic MLC capacitors normally provides adequate bypassing.

Grounding

When using the inverting drivers in the MIC4426 or MIC4428, individual ground returns for the input and output circuits or a ground plane are recommended for optimum switching speed. The voltage drop that occurs between the driver's ground and the input signal ground, during normal high-current switching, will behave as negative feedback and degrade switching speed.

Control Input

Unused driver inputs must be connected to logic high (which can be V_S) or ground. For the lowest quiescent current (< 500µA), connect unused inputs to ground. A logic-high signal will cause the driver to draw up to 9mA.

The drivers are designed with 100mV of control input hysteresis. This provides clean transitions and minimizes output stage current spikes when changing states. The control input voltage threshold is approximately 1.5V. The control input recognizes 1.5V up to V_S as a logic high and draws less than 1µA within this range.

The MIC4426/7/8 drives the TL494, SG1526/7, MIC38C42, TSC170 and similar switch-mode power supply integrated circuits.

Power Dissipation

Power dissipation should be calculated to make sure that the driver is not operated beyond its thermal ratings. Quiescent power dissipation is negligible. A practical value for total power dissipation is the sum of the dissipation caused by the load and the transition power dissipation ($P_L + P_T$).

Load Dissipation

Power dissipation caused by continuous load current (when driving a resistive load) through the driver's output resistance is:

$$P_L = I_L^2 R_O$$

For capacitive loads, the dissipation in the driver is:

$$P_L = f C_L V_S^2$$

Transition Dissipation

In applications switching at a high frequency, transition power dissipation can be significant. This occurs during switching transitions when the P-channel and N-channel output FETs are both conducting for the brief moment when one is turning on and the other is turning off.

$$P_T = 2 f V_S Q$$

Charge (Q) is read from the following graph:

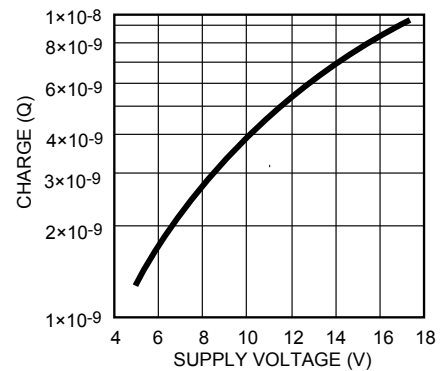

Crossover Energy Loss per Transition

Package Information

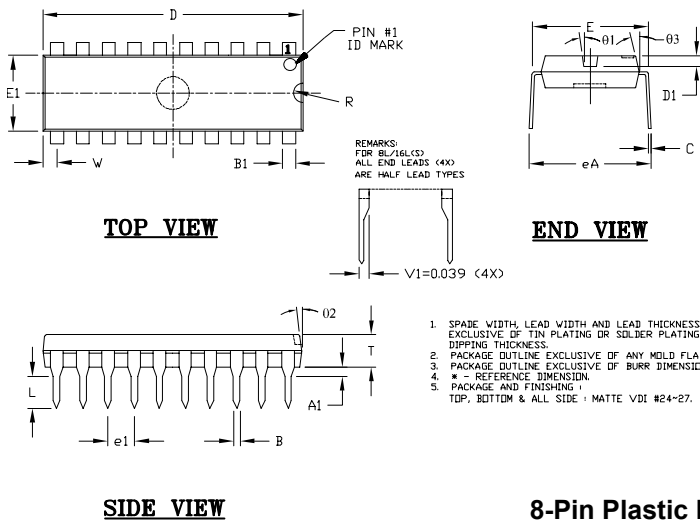
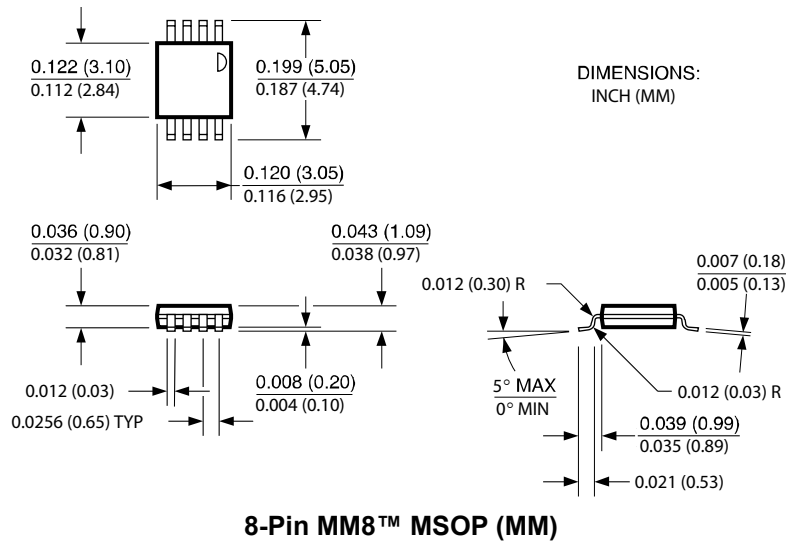

| LEAD TYPE | | 8LD | 14/16LD | 18LD | 20LD |
|-----------------------------------|----|---------------|------------------------------|---------------|---------------|
| STAND-OFF | A1 | 0.015 MIN | 0.015 MIN | 0.015 MIN | 0.015 MIN |
| LEAD WIDTH * | B | 0.018 | 0.018 | 0.018 | 0.018 |
| SPADE WIDTH * | B1 | 0.060 | 0.060 | 0.060 | 0.060 |
| LEAD THICKNESS * | C | 0.010 | 0.010 | 0.010 | 0.010 |
| LENGTH TOL ±0.004 | D | 0.375 | 0.750 | 0.890 | 1.020 |
| IDENT DEPTH | D1 | 0.030 ~ 0.060 | 0.030 ~ 0.060 | 0.030 ~ 0.060 | 0.030 ~ 0.060 |
| SHOULDER WIDTH OUTER TO OUTER | E | 0.300 ~ 0.325 | 0.300 ~ 0.325 | 0.300 ~ 0.325 | 0.300 ~ 0.325 |
| WIDTH TOL ±0.004 | E1 | 0.250 | 0.250 | 0.250 | 0.250 |
| LEAD SPREAD OUTER TO OUTER | eA | 0.320 ~ 0.370 | 0.320 ~ 0.370 | 0.320 ~ 0.370 | 0.320 ~ 0.370 |
| LEAD PITCH * | e1 | 0.100 | 0.100 | 0.100 | 0.100 |
| LEAD LENGTH TOL ±0.004 | L | 0.125 | 0.125 | 0.125 | 0.125 |
| IDENT RADIUS | R | 0.030 | 0.030 | 0.030 | 0.030 |
| TOTAL THICKNESS TOL ±0.004 | T | 0.130 | 0.130 | 0.130 | 0.130 |
| LEAD TO END PACKAGE | W | 0.025REF | 0.075REF14LD 0.025REF16LD | 0.045REF | 0.060REF |
| IDENT DRAFT TOL ±3° | Ø1 | 7° | 7° | 7° | 7° |
| END ANGLE (4x) TOL ±3° | Ø2 | 7° | 7° | 7° | 7° |
| SIDE ANGLE (4x) TOL ±3° | Ø3 | 7° | 7° | 7° | 7° |

MICREL INC. 2180 FORTUNE DRIVE SAN JOSE, CA 95131 USA
TEL + 1 (408) 944-0800 FAX + 1 (408) 474-1000 WEB <http://www.micrel.com>

This information furnished by Micrel in this data sheet is believed to be accurate and reliable. However no responsibility is assumed by Micrel for its use.
Micrel reserves the right to change circuitry and specifications at any time without notification to the customer.

Micrel Products are not designed or authorized for use as components in life support appliances, devices or systems where malfunction of a product can reasonably be expected to result in personal injury. Life support devices or systems are devices or systems that (a) are intended for surgical implant into the body or (b) support or sustain life, and whose failure to perform can be reasonably expected to result in a significant injury to the user. A Purchaser's use or sale of Micrel Products for use in life support appliances, devices or systems is a Purchaser's own risk and Purchaser agrees to fully indemnify Micrel for any damages resulting from such use or sale.

© 2003 Micrel, Incorporated.