

Circuit protection elements

●Circuit protection elements

Rohm's circuit protectors have a very reliable current cut-off capability that protects ICs and their circuits from accidental short circuit loads. Whether operated in AC or DC circuits, these circuit protectors have a very low internal resistance in normal operation, but safely and rapidly break the circuit when the current cutoff level is exceeded.

●Features

- 1) Cutoff is sharp and repeatable.
- 2) Low internal resistance and minimal voltage drop.
- 3) Incombustible.
- 4) Compact.
- 5) Rated for continuous use.
- 6) Good temperature characteristics.
- 7) Withstands surges well.
- 8) UL certified (UL certification number E107856).

●Application

Current surge protection

●Operation notes

Do not use this product on the primary side of commercial power supplies. Arcs that result after cutoff may damage the molding.

Surface mounting Type

●ICP-S series

Product name	Rated current (A)	Cutoff characteristics	Internal resistance Typ.(Ω)	Rated voltage (V)	Operating temperature (°C)	Storage temperature (°C)
ICP-S0.5	0.5	Fig.1	0.150	50	-55~+125	-55~+125
ICP-S0.7	0.7	Fig.2	0.084			
ICP-S1.0	1.0	Fig.3	0.061			
ICP-S1.2	1.2	Fig.4	0.048			
ICP-S1.8	1.8	Fig.5	0.032			
ICP-S2.3	2.3	Fig.6	0.026			

Transistors

●Cutoff characteristics

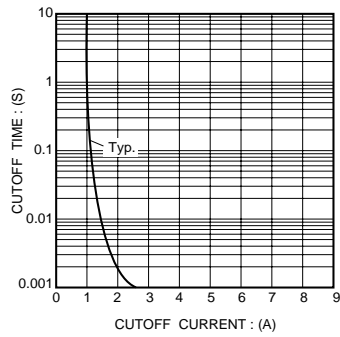

Fig.1 ICP-S0.5

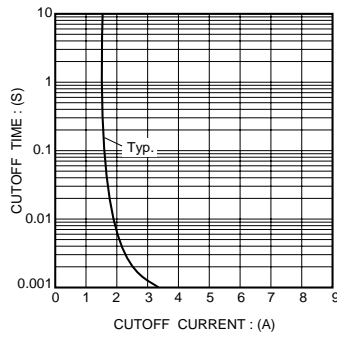

Fig.2 ICP-S0.7

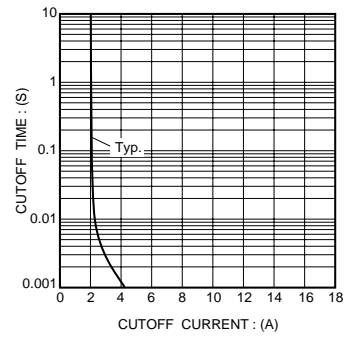

Fig.3 ICP-S1.0

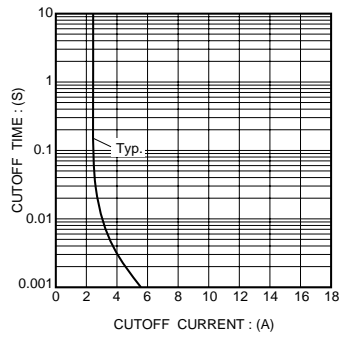

Fig.4 ICP-S1.2

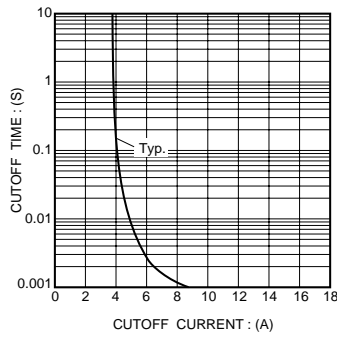

Fig.5 ICP-S1.8

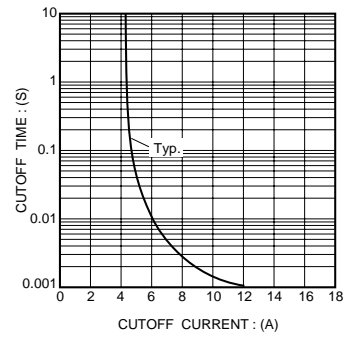
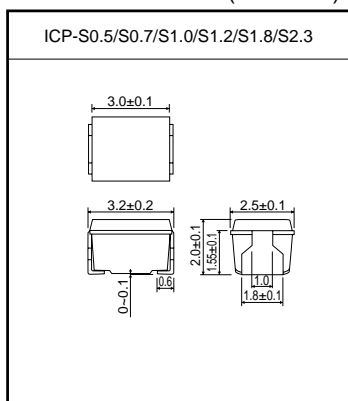

Fig.6 ICP-S2.3

The cutoff characteristics shown are typical. For further details of how to use these protectors, please request the technical documentation from your Rohm representative.

●External dimensions (Units : mm)



Transistors

●Packaging specifications

ICP-S Type	Package type	Taping
	Symbol	TN
	Basic ordering unit (pieces)	2000
ICP-S0.5		○
ICP-S0.7		○
ICP-S1.0		○
ICP-S1.2		○
ICP-S1.8		○
ICP-S2.3		○

●Taping specifications (Units : mm)

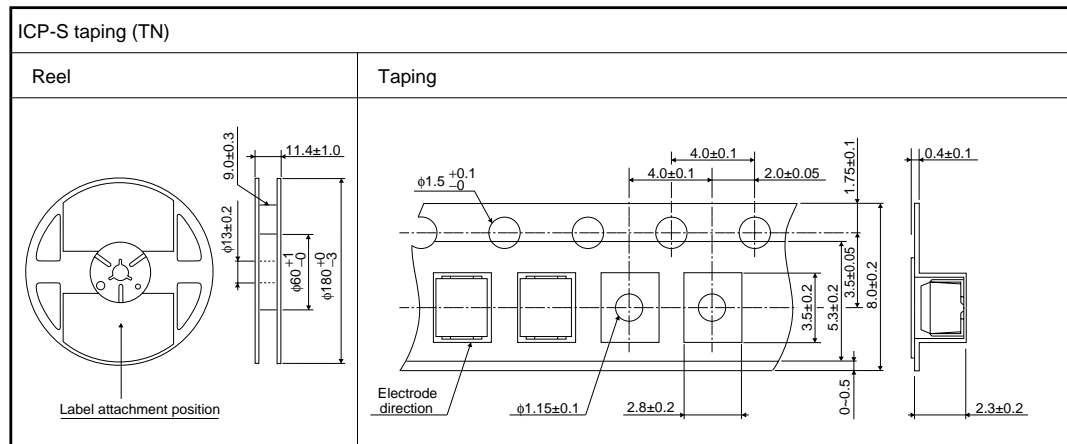

Transistors

Leaded type

ICP-N series

Product name	Rated current (A)	Cutoff characteristics	Internal resistance Typ.(Ω)	Rated voltage (V)	Operating temperature (°C)	Storage temperature(°C)
ICP-N10	0.4	Fig.1	0.220	50	-55~+125	-55~+125
ICP-N15	0.6	Fig.2	0.135			
ICP-N20	0.8	Fig.3	0.100			
ICP-N25	1.0	Fig.4	0.070			
ICP-N38	1.5	Fig.5	0.042			
ICP-N50	2.0	Fig.6	0.035			
ICP-N70	2.5	Fig.7	0.023			

●Cutoff characteristics

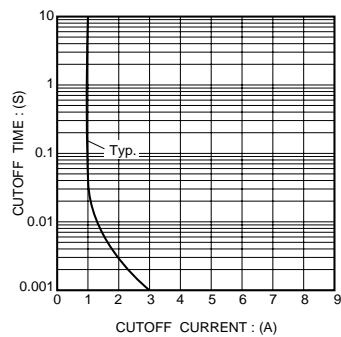

Fig.1 ICP-N10

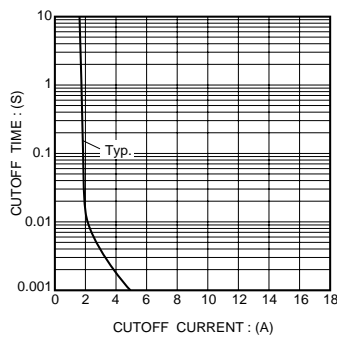

Fig.2 ICP-N15

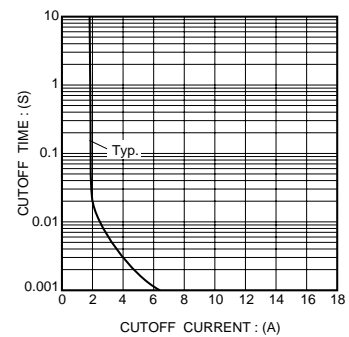

Fig.3 ICP-N20

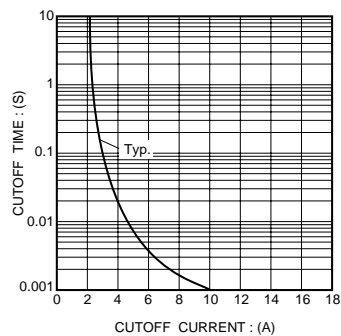

Fig.4 ICP-N25

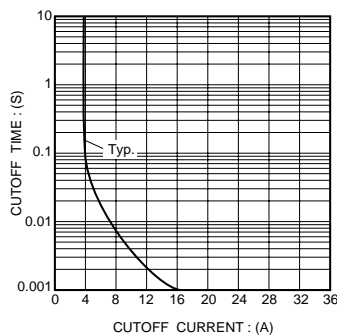

Fig.5 ICP-N38

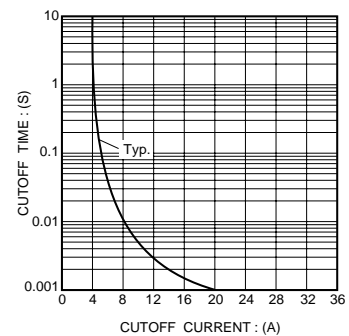

Fig.6 ICP-N50



Transistors

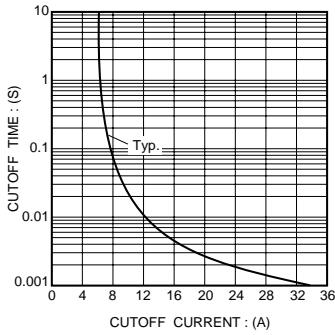
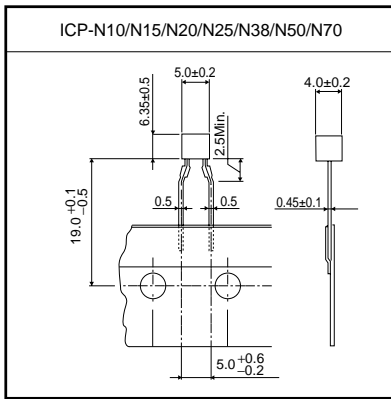

Fig.7 ICP-N70

The cutoff characteristics given represent typical values. Technical documentation regarding ways of using circuit protectors is available from your Rohm representative.

●External dimensions (Units : mm)



●Packaging specifications

	Packaging type	Taping
ICP-N	Symbol	T104
	Basic ordering unit (pieces)	3000
Type		
ICP-N10/N15/N20/N25/N38/N50/N70		○

●Taping specifications (Units : mm)

