

10 9 8 7 6 5 4 3 2 19418

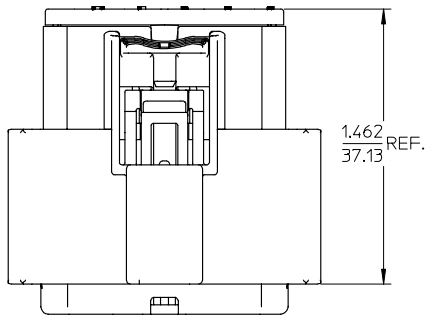

| | | |
|-----------------|-------------|-----|
| 19418-0025 | 16-14 | NO |
| 19418-0024 | 22-18 | |
| 19418-0013 | 16-14 | YES |
| 19418-0014 | 22-18 | |
| MATERIAL NUMBER | UL WIRE AWG | CPA |

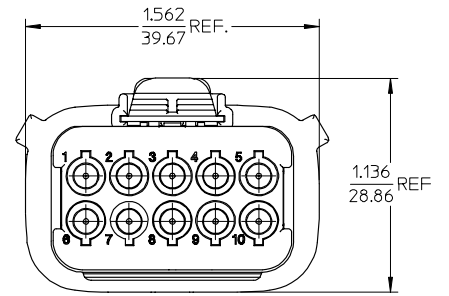
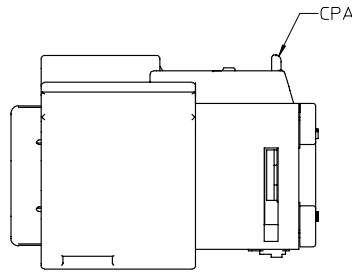
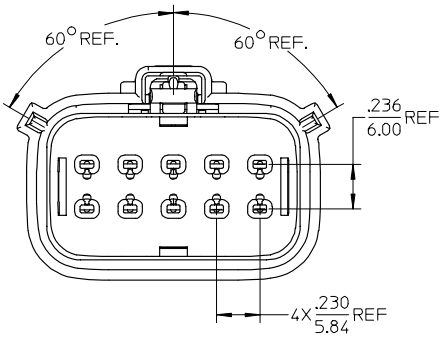
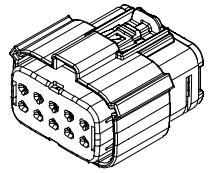

NOTES:

1. MATERIALS:
HOUSING: POLYESTER (PBT), GLASS FILLED, UL94 V-0, COLOR: BLACK.
SEALS: SILICONE RUBBER.
2. PRODUCT SPECIFICATION: PS-19417-001.
3. PACKAGING SPECIFICATION: PK-19418-001.
4. MATES WITH: 19419 SERIES PLUG ASSEMBLIES.
5. USE CONNECTOR WITH FEMALE CRIMP TERMINAL SERIES 19420.

| | | | | | | | | |
|--|--|---------------------------------------|-----------------|-----------------------|---|--|-------------------|------------------------|
| REVISED EC NO: EITC2006-0164 DRAWN: PAWLICK 2006/01/12 CHKD: PAWLICK 2006/01/12 APPROVED: RDEROSS 2006/01/13 B1 | QUALITY SYMBOLS | GENERAL TOLERANCES (UNLESS SPECIFIED) | | DIMENSION STYLE IN/MM | | SCALE 2:1 | DESIGN UNITS INCH | THIRD ANGLE PROJECTION |
| | ▽=0 ▽=0 | mm | INCH | DRAWN BY BRUPERT | DATE 01/22/03 | TITLE 10 WAY RECEPTACLE ASSEMBLY, KEY A POLARIZATION | | |
| | | 4 PLACES ± .015 | 3 PLACES ± .015 | CHECKED BY JPAWLICK1 | DATE 01/23/03 | MOLEX INCORPORATED | | |
| | | 2 PLACES ± 0.38 | 1 PLACE ± .015 | APPROVED BY RDEROSS | DATE 01/25/03 | DOCUMENT NO. SD-19418-005 | | |
| | ANGULAR ± 1° | | MATERIAL NO. | | SHEET NO. | | 1 OF 1 | |
| | DRAFT WHERE APPLICABLE MUST REMAIN WITHIN DIMENSIONS | | SEE CHART | | THIS DRAWING CONTAINS INFORMATION THAT IS PROPRIETARY TO MOLEX INCORPORATED AND SHOULD NOT BE USED WITHOUT WRITTEN PERMISSION | | | |

9 8 7 6 5 4 3 2 1