

参考パターンレイアウト
RECOMMENDED PATTERN DIM(REF)
SCALE: 5-1

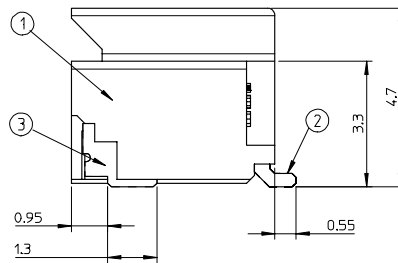
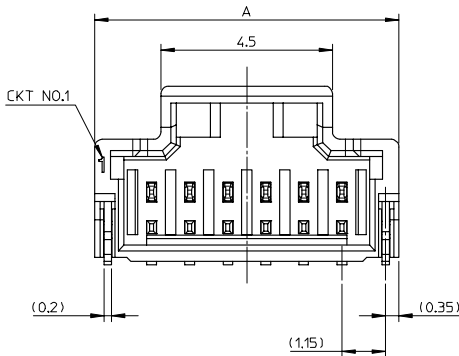

番号 NO.	部品 PART	材質 MATERIAL
①	ウェハー WAFER	耐熱ナイロン, UL94V-0 HEAT RESISTANCE NYLON, UL94V-0
②	ソルダーピン SOLDER PIN	リン青銅 PHOSPHOR BRONZE オズメッキ : 1 MICRO METER MINIMUM. TIN PLATING ニッケル下地メッキ : 1 MICRO METER MINIMUM. NICKEL UNDER PLATING
③	ネイル NAIL	黄銅 BRASS オズメッキ : 1 MICRO METER MINIMUM. TIN PLATING ニッケル下地メッキ : 1 MICRO METER MINIMUM. NICKEL UNDER PLATING

14.0	17.0	501568-15*9	15	501568-***9
13.0	16.0	501568-14*9	14	
12.0	15.0	501568-13*9	13	
11.0	14.0	501568-12*9	12	
10.0	13.0	501568-11*9	11	
9.0	12.0	501568-10*9	10	
8.0	11.0	501568-09*9	9	
7.0	10.0	501568-08*9	8	
6.0	9.0	501568-07*9	7	
5.0	8.0	501568-06*9	6	
B	A	MATERIAL NO.	CKT	MODEL NO.

NOTES

- かん合相手 : 501330-****
MATE WITH : 501330-****
- ソルダーピン及びネイルの平坦度は0.1MAX.
SOLDER PIN AND NAIL COPLANARITY TO BE 0.1MAX.
- ⚠ 偶数 = 偶数に適用
APPLY FOR CKT SIZE=EVEN
- 2-5 極は, SD-501568-001 を参照下さい.
REFER TO SD-501568-001 ABOUT 2-5CKT.
- 5.ELV AND RoHS COMPLIANT.

REVISED EC NO: J2008-1014 DRAWN: AOYAGI CHKD: KYODA APPR: NUKITA	DESCRIPTION	GENERAL TOLERANCES (UNLESS SPECIFIED)	DIMENSION STYLE MM ONLY	SCALE 10:1	DESIGN UNITS METRIC	THIRD ANGLE PROJECTION
	REV	10 UNDER ±0.2	DRAWN BY AMIZUMURA	DATE 2005/01/19	TITLE 1.0 WIRE TO BOARD CONN. 1-ROW R/A WAFER ASSY 6-15CKT	
		10 OVER 30 UNDER ±0.25	CHECKED BY MYAGI	DATE 2005/01/19	MOLEX INCORPORATED	
		30 OVER ±0.3	APPROVED BY ANODA	DATE 2005/01/19	DOCUMENT NO. SD-501568-002	SHEET NO. 1 OF 2
	ANGULAR ±3 °	DRAFT WHERE APPLICABLE MUST REMAIN WITHIN DIMENSIONS	MATERIAL NO.	SEE TABLE	THIS DRAWING CONTAINS INFORMATION THAT IS PROPRIETARY TO MOLEX INCORPORATED AND SHOULD NOT BE USED WITHOUT WRITTEN PERMISSION	
			SIZE A3			

10 | 9 | 8 | 7 | 6 | 5 | 4 | 3 | 2 | 1

紫 VIOLET	橙 ORANGE	茶 BROWN	緑 GREEN	青 BLUE	黄 YELLOW	赤 RED	色 COLOR
501568-1599	501568-1589	501568-1579	501568-1569	501568-1549	501568-1539	501568-1529	15
501568-1499	501568-1489	501568-1479	501568-1469	501568-1449	501568-1439	501568-1429	14
501568-1399	501568-1389	501568-1379	501568-1369	501568-1349	501568-1339	501568-1329	13
501568-1299	501568-1289	501568-1279	501568-1269	501568-1249	501568-1239	501568-1229	12
501568-1199	501568-1189	501568-1179	501568-1169	501568-1149	501568-1139	501568-1129	11
501568-1099	501568-1089	501568-1079	501568-1069	501568-1049	501568-1039	501568-1029	10
501568-0999	501568-0989	501568-0979	501568-0969	501568-0949	501568-0939	501568-0929	9
501568-0899	501568-0889	501568-0879	501568-0869	501568-0849	501568-0839	501568-0829	8
501568-0799	501568-0789	501568-0779	501568-0769	501568-0749	501568-0739	501568-0729	7
501568-0699	501568-0689	501568-0679	501568-0669	501568-0649	501568-0639	501568-0629	6
MATERIAL NO.	MATERIAL NO.	MATERIAL NO.	MATERIAL NO.	MATERIAL NO.	MATERIAL NO.	MATERIAL NO.	MODEL NO.

自然色 NATURAL	色 COLOR
501568-1509	15
501568-1409	14
501568-1309	13
501568-1209	12
501568-1109	11
501568-1009	10
501568-0909	9
501568-0809	8
501568-0709	7
501568-0609	6
MATERIAL NO.	MODEL NO.

REVISED EC NO: J2008-1014 DRWN: YAGI CHK: KYODA APPR: NIKITA	2007/10/01 2007/10/01 2007/10/01	GENERAL TOLERANCES (UNLESS SPECIFIED)	DIMENSION STYLE MM ONLY	SCALE ---	DESIGN UNITS METRIC	THIRD ANGLE PROJECTION
	DESCRIPTION	10 UNDER ±0.2 10 OVER 30 UNDER ±0.25 30 OVER ±0.3 ANGULAR ±3°	DRAWN BY AMIZUMURA DATE 2005/01/19	TITLE 1.0 WIRE TO BOARD CONN. 1-ROW R/A WAFER ASSY 6-15CKT		
	REV	DRAFT WHERE APPLICABLE MUST REMAIN WITHIN DIMENSIONS	CHECKED BY MYAGI DATE 2005/01/19	MOLEX INCORPORATED		
		SEE TABLE	APPROVED BY ANODA DATE 2005/01/19	MATERIAL NO. SD-501568-002	DOCUMENT NO.	SHEET NO. 2 OF 2

10 9 8 7 6 5 4 3 2 1

F
E
D
C
B
A

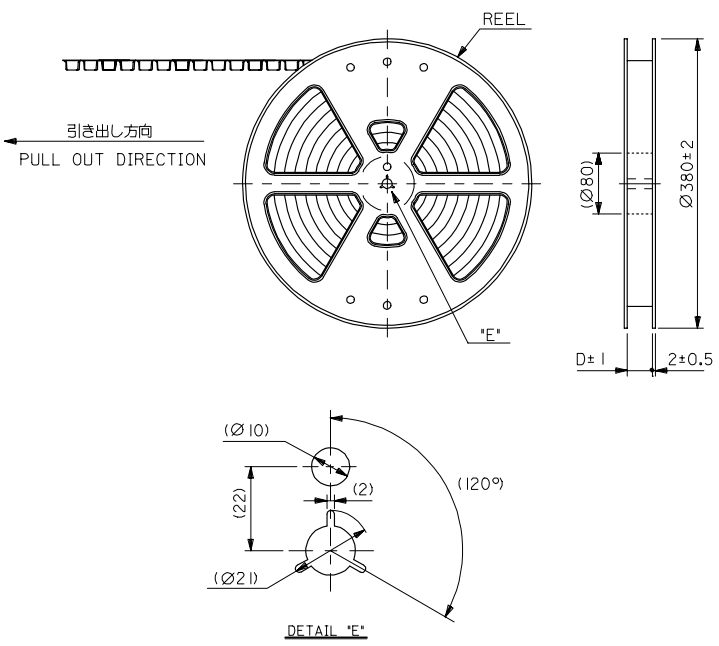

NOTES

- 製品詳細寸法は製品単体図面を参照して下さい。
FOR DETAIL OF CONNECTOR DIMENSIONS, PLEASE SEE THE DRAWING OF CONNECTOR ITSELF (NOT PACKAGED).
- 梱包数量: 1300個/リール
NUMBER OF CONNECTORS: 1300 PIECES/REEL
- リードテープ長さ
LEAD TAPE LENGTH
- 材料
MATERIAL
キャリアテープ: ポリプロピレン
CARRIER TAPE: POLYPROPYLENE
トップテープ: PET, PE, REF
TOP TAPE
リール: ポリスチレン (リサイクル材を含む)
REEL: POLYSTYRENE (RECYCLE MATERIAL CONTAINED)
- ELV AND RoHS COMPLIANT.

REVISED EC NO: J2008-1014 2007/10/01 DRWN: YADYAGI CHK: KATOYODA 2007/10/01 APPR: NUKITA 2007/10/01	GENERAL TOLERANCES (UNLESS SPECIFIED)		DIMENSION STYLE MM ONLY		SCALE ---	DESIGN UNITS METRIC	THIRD ANGLE PROJECTION
	10 UNDER	± 0.2	DRAWN BY AMIZUMURA	DATE 2005/11/26	TITLE 1.0 WIRE TO BOARD CONN. WAFER ASS'Y (1-ROW R/A) EMBTP PKG MOLEX INCORPORATED		
	10 OVER 30 UNDER	± 0.25	CHECKED BY MYAGI	DATE 2005/11/26			
	30 OVER	± 0.3	APPROVED BY ANODA	DATE 2005/11/26			
ANGULAR ±1 °		MATERIAL NO. SEE TABLE		DOCUMENT NO. SD-501568-006		SHEET NO. 1 OF 3	
DRAFT WHERE APPLICABLE MUST REMAIN WITHIN DIMENSIONS		THIS DRAWING CONTAINS INFORMATION THAT IS PROPRIETARY TO MOLEX INCORPORATED AND SHOULD NOT BE USED WITHOUT WRITTEN PERMISSION					

fb_frame_A3_1_ME_S
Rev. E 2006/04/15

9 8 7 6 5 4 3 2 1 EN-02JA(021)

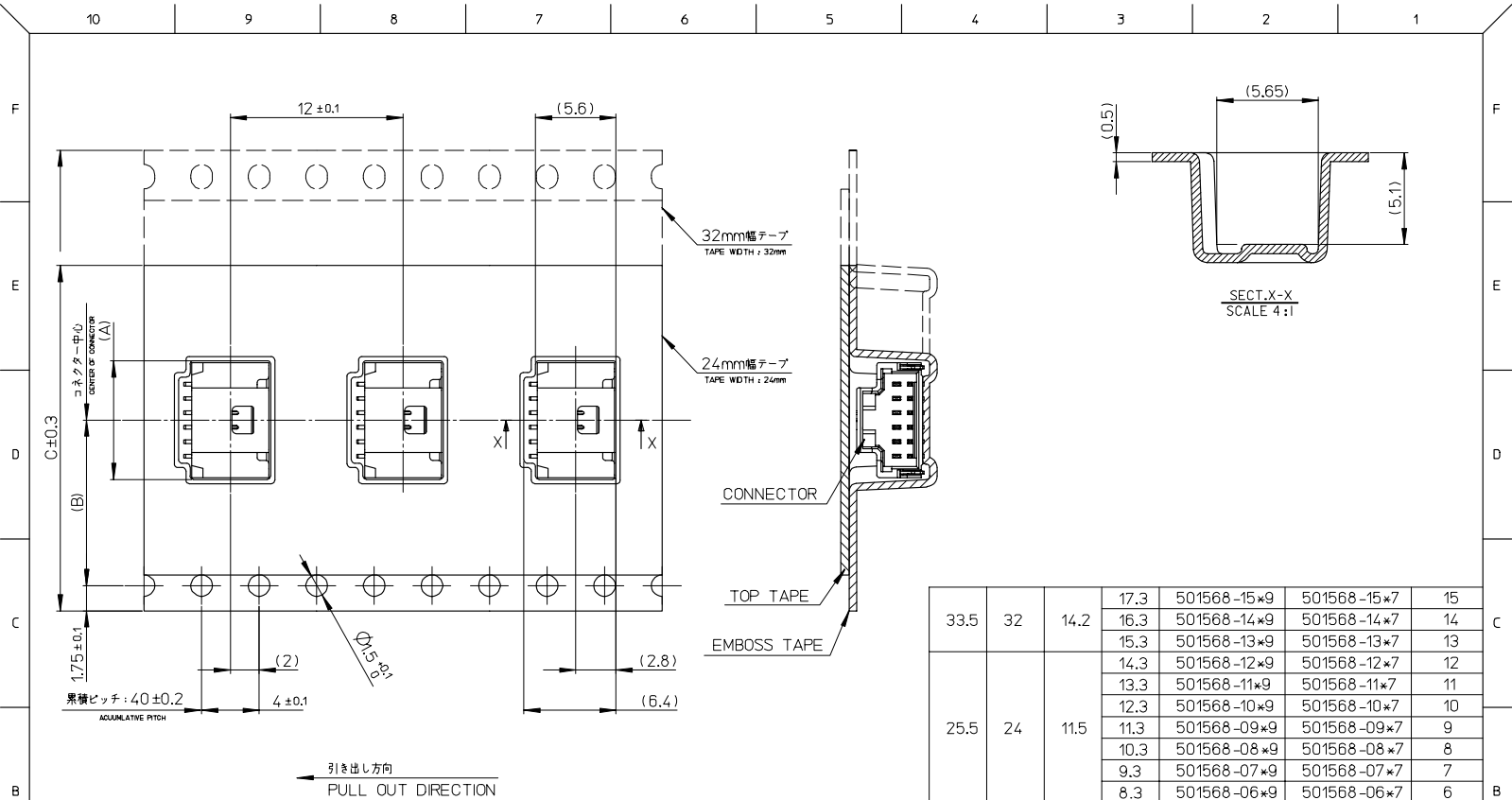

33.5	32	14.2	17.3	501568-15*9	501568-15*7	15
			16.3	501568-14*9	501568-14*7	14
25.5	24	11.5	15.3	501568-13*9	501568-13*7	13
			14.3	501568-12*9	501568-12*7	12
			13.3	501568-11*9	501568-11*7	11
			12.3	501568-10*9	501568-10*7	10
			11.3	501568-09*9	501568-09*7	9
			10.3	501568-08*9	501568-08*7	8
D	C	(B)	(A)	CONNECTOR	MATERIAL NO.	CKTS.

REVISED EC NO: J2008-1014 DRWN: YAGYAGI CHK: KATOYODA APPR: NUKITA	2007/10/01	GENERAL TOLERANCES (UNLESS SPECIFIED)		DIMENSION STYLE		SCALE	DESIGN UNITS	THIRD ANGLE PROJECTION
	2007/10/01	10 UNDER	± 0.2	MM ONLY		---	METRIC	
	2007/10/01	10 OVER 30 UNDER	± 0.25	DRAWN BY		DATE	TITLE	
		30 OVER	± 0.3	AMIZUMURA		2005/11/26	1.0 WIRE TO BOARD CONN. WAFER ASS'Y (1-ROW R/A) EMBTP PKG	
		ANGULAR	± 3 °	CHECKED BY		DATE	MOLEX INCORPORATED	
DESCRIPTION		DRAFT WHERE APPLICABLE MUST REMAIN WITHIN DIMENSIONS		APPROVED BY		DATE	DOCUMENT NO.	SHEET NO.
A				ANODA		2005/11/26	SD-501568-006	2 OF 3
				MATERIAL NO.		SEE TABLE		THIS DRAWING CONTAINS INFORMATION THAT IS PROPRIETARY TO MOLEX INCORPORATED AND SHOULD NOT BE USED WITHOUT WRITTEN PERMISSION
				SIZE		A3		

10 9 8 7 6 5 4 3 2 1

F

E

D

C

B

A

F

E

D

C

B

A

紫 VIOLET		橙 ORANGE		茶 BROWN		色 COLOR		
501568-1599	501568-1597	501568-1589	501568-1587	501568-1579	501568-1577	15	501568-***7	
501568-1499	501568-1497	501568-1489	501568-1487	501568-1479	501568-1477	14		
501568-1399	501568-1397	501568-1389	501568-1387	501568-1379	501568-1377	13		
501568-1299	501568-1297	501568-1289	501568-1287	501568-1279	501568-1277	12		
501568-1199	501568-1197	501568-1189	501568-1187	501568-1179	501568-1177	11		
501568-1099	501568-1097	501568-1089	501568-1087	501568-1079	501568-1077	10		
501568-0999	501568-0997	501568-0989	501568-0987	501568-0979	501568-0977	9		
501568-0899	501568-0897	501568-0889	501568-0887	501568-0879	501568-0877	8		
501568-0799	501568-0797	501568-0789	501568-0787	501568-0779	501568-0777	7		
501568-0699	501568-0697	501568-0689	501568-0687	501568-0679	501568-0677	6		
CONNECTOR	MATERIAL NO.	CONNECTOR	MATERIAL NO.	CONNECTOR	MATERIAL NO.	CKT.		MODEL NO.
緑 GREEN		青 BLUE		赤 RED		色 COLOR		
501568-1569	501568-1567	501568-1549	501568-1547	501568-1529	501568-1527	15		501568-***7
501568-1469	501568-1467	501568-1449	501568-1447	501568-1429	501568-1427	14		
501568-1369	501568-1367	501568-1349	501568-1347	501568-1329	501568-1327	13		
501568-1269	501568-1267	501568-1249	501568-1247	501568-1229	501568-1227	12		
501568-1169	501568-1167	501568-1149	501568-1147	501568-1129	501568-1127	11		
501568-1069	501568-1067	501568-1049	501568-1047	501568-1029	501568-1027	10		
501568-0969	501568-0967	501568-0949	501568-0947	501568-0929	501568-0927	9		
501568-0869	501568-0867	501568-0849	501568-0847	501568-0829	501568-0827	8		
501568-0769	501568-0767	501568-0749	501568-0747	501568-0729	501568-0727	7		
501568-0669	501568-0667	501568-0649	501568-0647	501568-0629	501568-0627	6		
CONNECTOR	MATERIAL NO.	CONNECTOR	MATERIAL NO.	CONNECTOR	MATERIAL NO.	CKT.	MODEL NO.	
自然色 NATURAL		色 COLOR						
501568-1509	501568-1507	15	501568-**07					
501568-1409	501568-1407	14						
501568-1309	501568-1307	13						
501568-1209	501568-1207	12						
501568-1109	501568-1107	11						
501568-1009	501568-1007	10						
501568-0909	501568-0907	9						
501568-0809	501568-0807	8						
501568-0709	501568-0707	7						
501568-0609	501568-0607	6						
CONNECTOR	MATERIAL NO.	CKT.	MODEL NO.					

REVISED EC NO: J2008-1014 2007/10/01 DRWN:YAOYAGI CHK:KATOYODA 2007/10/01 APPR:NIKIITA 2007/10/01	GENERAL TOLERANCES (UNLESS SPECIFIED)		DIMENSION STYLE MM ONLY		SCALE ---	DESIGN UNITS METRIC	THIRD ANGLE PROJECTION
	10 UNDER	± ---	DRAWN BY AMIZUMURA	DATE 2005/11/26	TITLE 1.0 WIRE TO BOARD CONN. WAFER ASSY (1-ROW R/A) EMBTB PKG MOLEX INCORPORATED		
	10 OVER 30 UNDER	± ---	CHECKED BY YAGI	DATE 2005/11/26			
	30 OVER	± ---	APPROVED BY ANODA	DATE 2005/11/26			
ANGULAR	± --- °	MATERIAL NO. SEE TABLE		DOCUMENT NO. SD-501568-006	SHEET NO. 3 OF 3		
DRAFT WHERE APPLICABLE MUST REMAIN WITHIN DIMENSIONS		SIZE A3	THIS DRAWING CONTAINS INFORMATION THAT IS PROPRIETARY TO MOLEX INCORPORATED AND SHOULD NOT BE USED WITHOUT WRITTEN PERMISSION				