

Smart Highside Power Switch

Features

- Overload protection
- Current limitation
- Short circuit protection
- Thermal shutdown
- Overvoltage protection (including load dump)
- Fast demagnetization of inductive loads
- Reverse battery protection¹⁾
- Undervoltage and overvoltage shutdown with auto-restart and hysteresis
- Open drain diagnostic output
- Open load detection in ON-state
- CMOS compatible input
- Loss of ground and loss of V_{bb} protection
- Electrostatic discharge (ESD) protection

Product Summary

Overvoltage protection	$V_{bb(AZ)}$	65	V
Operating voltage	$V_{bb(on)}$	4.7 ... 42	V
On-state resistance	R_{ON}	220	mΩ
Load current (ISO)	$I_L(ISO)$	1.8	A
Current limitation	$I_L(SCr)$	2.7	A

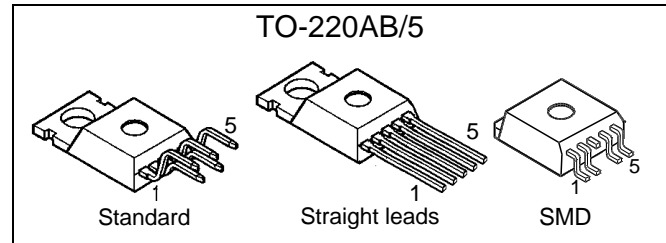

Application

- μ C compatible power switch with diagnostic feedback for 12 V and 24 V DC grounded loads
- Most suitable for inductive loads
- Replaces electromechanical relays, fuses and discrete circuits

General Description

N channel vertical power FET with charge pump, ground referenced CMOS compatible input and diagnostic feedback, monolithically integrated in Smart SIPMOS® technology. Fully protected by embedded protection functions.

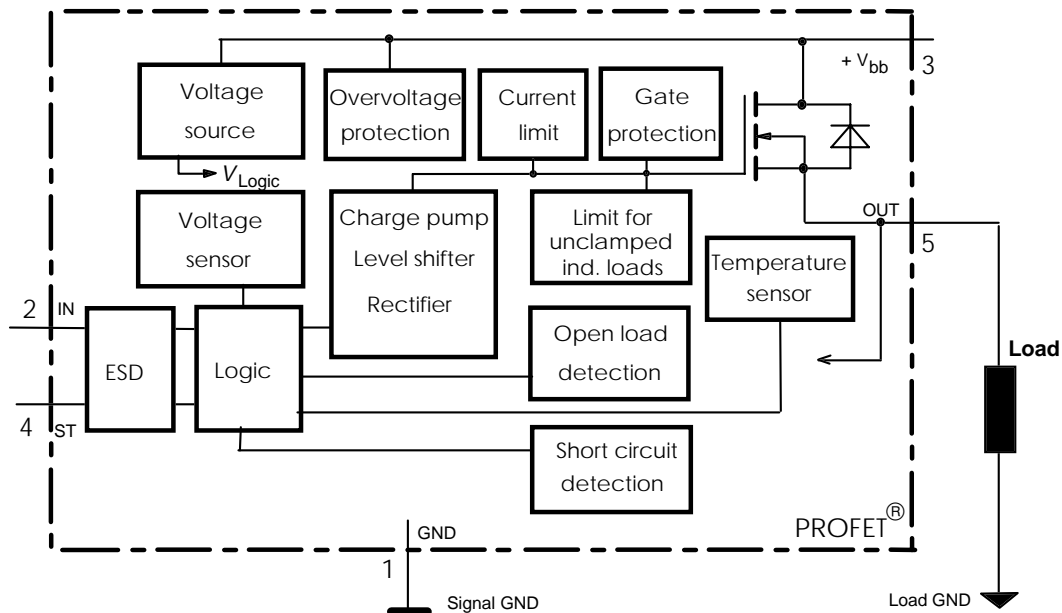

1) With external current limit (e.g. resistor $R_{GND}=150 \Omega$) in GND connection, resistors in series with IN and ST connections, reverse load current limited by connected load.

Pin	Symbol		Function
1	GND	-	Logic ground
2	IN	I	Input, activates the power switch in case of logical high signal
3	V _{bb}	+	Positive power supply voltage, the tab is shorted to this pin
4	ST	S	Diagnostic feedback, low on failure
5	OUT (Load, L)	O	Output to the load

Maximum Ratings at $T_j = 25\text{ °C}$ unless otherwise specified

Parameter	Symbol	Values	Unit
Supply voltage (overvoltage protection see page 3)	V_{bb}	65	V
Load dump protection ²⁾ $V_{LoadDump} = U_A + V_S$, $U_A = 13.5\text{ V}$ $R_i^{3)} = 2\ \Omega$, $R_L = 6.6\ \Omega$, $t_d = 400\text{ ms}$, IN= low or high	$V_{Load\ dump}^{4)}$	100	V
Load current (Short circuit current, see page 4)	I_L	self-limited	A
Operating temperature range	T_j	-40 ... +150	°C
Storage temperature range	T_{stg}	-55 ... +150	
Power dissipation (DC), $T_C \leq 25\text{ °C}$	P_{tot}	50	W
Inductive load switch-off energy dissipation, single pulse $V_{bb} = 12\text{V}$, $T_{j,start} = 150\text{°C}$, $T_C = 150\text{°C}$ const. $I_L = 1.8\text{ A}$, $Z_L = 2.3\text{ H}$, $0\ \Omega$:	E_{AS}	4.5	J
Electrostatic discharge capability (ESD) (Human Body Model) acc. MIL-STD883D, method 3015.7 and ESD assn. std. S5.1-1993	IN: V_{ESD} all other pins:	1 2	kV
Input voltage (DC)	V_{IN}	-0.5 ... +6	V
Current through input pin (DC)	I_{IN}	±5.0	mA
Current through status pin (DC)	I_{ST}	±5.0	
see internal circuit diagrams page 6			

Thermal Characteristics



Parameter and Conditions	Symbol	Values			Unit
		min	typ	max	
Thermal resistance chip - case:	R_{thJC}	--	--	2.5	K/W
junction - ambient (free air):	R_{thJA}	--	--	75	
SMD version, device on PCB ⁵⁾ :		--	35	--	

- 2) Supply voltages higher than $V_{bb(AZ)}$ require an external current limit for the GND and status pins, e.g. with a $150\ \Omega$ resistor in the GND connection and a $15\text{ k}\Omega$ resistor in series with the status pin. A resistor for the protection of the input is integrated.
- 3) R_i = internal resistance of the load dump test pulse generator
- 4) $V_{Load\ dump}$ is setup without the DUT connected to the generator per ISO 7637-1 and DIN 40839
- 5) Device on $50\text{mm} \times 50\text{mm} \times 1.5\text{mm}$ epoxy PCB FR4 with 6cm^2 (one layer, $70\ \mu\text{m}$ thick) copper area for V_{bb} connection. PCB is vertical without blown air.

Electrical Characteristics

Parameter and Conditions at $T_j = 25\text{ °C}$, $V_{bb} = 12\text{ V}$ unless otherwise specified	Symbol	Values			Unit
		min	typ	max	

Load Switching Capabilities and Characteristics

On-state resistance (pin 3 to 5) $I_L = 1.6\text{ A}$	$T_j = 25\text{ °C}$: $T_j = 150\text{ °C}$:	R_{ON}	--	190 390	220 440	mΩ
Nominal load current, ISO Norm (pin 3 to 5) $V_{ON} = 0.5\text{ V}$, $T_C = 85\text{ °C}$		$I_{L(ISO)}$	1.6	1.8	--	A
Output current (pin 5) while GND disconnected or GND pulled up, $V_{bb} = 30\text{ V}$, $V_{IN} = 0$, see diagram page 7, $T_j = -40...+150\text{ °C}$		$I_{L(GNDhigh)}$	--	--	1	mA
Turn-on time IN  to 90% V_{OUT} :		t_{on}	12	--	125	μs
Turn-off time IN  to 10% V_{OUT} :		t_{off}	5	--	85	
Slew rate on 10 to 30% V_{OUT} , $R_L = 12\text{ Ω}$, $T_j = -40...+150\text{ °C}$		dV/dt_{on}	--	--	3	V/μs
Slew rate off 70 to 40% V_{OUT} , $R_L = 12\text{ Ω}$, $T_j = -40...+150\text{ °C}$		$-dV/dt_{off}$	--	--	6	V/μs

Operating Parameters

Operating voltage ⁶⁾	$T_j = -40...+150\text{ °C}$:	$V_{bb(on)}$	4.7	--	42	V
Undervoltage shutdown	$T_j = 25\text{ °C}$:	$V_{bb(under)}$	2.9	--	4.5	V
	$T_j = -40...+150\text{ °C}$:		2.7	--	4.7	
Undervoltage restart	$T_j = -40...+150\text{ °C}$:	$V_{bb(u\ rst)}$	--	--	4.9	V
Undervoltage restart of charge pump see diagram page 12		$V_{bb(ucp)}$	--	5.6	6.0	V
Undervoltage hysteresis $\Delta V_{bb(under)} = V_{bb(u\ rst)} - V_{bb(under)}$		$\Delta V_{bb(under)}$	--	0.1	--	V
Overvoltage shutdown	$T_j = -40...+150\text{ °C}$:	$V_{bb(over)}$	42	--	52	V
Overvoltage restart	$T_j = -40...+150\text{ °C}$:	$V_{bb(o\ rst)}$	40	--	--	V
Overvoltage hysteresis	$T_j = -40...+150\text{ °C}$:	$\Delta V_{bb(over)}$	--	0.1	--	V
Overvoltage protection ⁷⁾ $I_{bb} = 4\text{ mA}$	$T_j = -40...+150\text{ °C}$:	$V_{bb(AZ)}$	65	70	--	V
Standby current (pin 3) $V_{IN} = 0$	$T_j = -40...+25\text{ °C}$:	$I_{bb(off)}$	--	10	15	μA
	$T_j = 150\text{ °C}$:		--	18	25	
Leakage output current (included in $I_{bb(off)}$) $V_{IN} = 0$		$I_{L(off)}$	--	--	20	μA
Operating current (Pin 1) ⁸⁾ , $V_{IN} = 5\text{ V}$, $T_j = -40...+150\text{ °C}$		I_{GND}	--	1	2.1	mA

⁶⁾ At supply voltage increase up to $V_{bb} = 5.6\text{ V}$ typ without charge pump, $V_{OUT} \approx V_{bb} - 2\text{ V}$

⁷⁾ Measured without load. See also $V_{ON(CL)}$ in table of protection functions and circuit diagram page 6.

Protection Functions

Initial peak short circuit current limit (pin 3 to 5) ⁹⁾ , (max 450 μ s if $V_{ON} > V_{ON(SC)}$)	$I_{L(SCp)}$				
$T_j = -40^\circ\text{C}$: $T_j = 25^\circ\text{C}$: $T_j = +150^\circ\text{C}$:		4.0 3.5 2.0	-- 5.5 3.5	11 10 7.5	A
Overload shutdown current limit $V_{ON} = 8\text{ V}$, $T_j = T_{jt}$ (see timing diagrams, page 10)	$I_{L(SCr)}$	--	2.7	--	A
Short circuit shutdown delay after input pos. slope $V_{ON} > V_{ON(SC)}$, min value valid only, if input "low" time exceeds 60 μ s	$t_{d(SC)}$	--	--	450	μ s
Output clamp (inductive load switch off) at $V_{OUT} = V_{bb} - V_{ON(CL)}$ $I_L = 40\text{ mA}$, $T_j = -40..+150^\circ\text{C}$: $I_L = 1\text{ A}$, $T_j = -40..+150^\circ\text{C}$:	$V_{ON(CL)}$	61 --	68 --	73 75	V
Short circuit shutdown detection voltage (pin 3 to 5)	$V_{ON(SC)}$	--	8.5	--	V
Thermal overload trip temperature	T_{jt}	150	--	--	$^\circ\text{C}$
Thermal hysteresis	ΔT_{jt}	--	10	--	K
Reverse battery (pin 3 to 1) ¹⁰⁾	$-V_{bb}$	--	--	32	V

Diagnostic Characteristics

Open load detection current (on-condition)	$I_L(OL)$				
$T_j = -40..+150^\circ\text{C}$:		2	--	150	mA

Input and Status Feedback¹¹⁾

Input turn-on threshold voltage $T_j = -40..+150^\circ\text{C}$:	$V_{IN(T+)}$	1.5	--	2.4	V
Input turn-off threshold voltage $T_j = -40..+150^\circ\text{C}$:	$V_{IN(T-)}$	1.0	--	--	V
Input threshold hysteresis	$\Delta V_{IN(T)}$	--	0.5	--	V
Off state input current (pin 2), $V_{IN} = 0.4\text{ V}$	$I_{IN(off)}$	1	--	30	μA
On state input current (pin 2), $V_{IN} = 5\text{ V}$	$I_{IN(on)}$	10	25	70	μA
Status invalid after positive input slope (short circuit)	$t_{d(ST\ SC)}$	--	--	450	μs
Status invalid after positive input slope (open load)	$t_{d(ST)}$	300	--	1400	μs
Status output (open drain) Zener limit voltage $T_j = -40..+150^\circ\text{C}$, $I_{ST} = +50\text{ uA}$: ST low voltage $T_j = -40..+150^\circ\text{C}$, $I_{ST} = +1.6\text{ mA}$:	$V_{ST(high)}$ $V_{ST(low)}$	5.0 --	6 --	-- 0.4	V

8) Add I_{ST} , if $I_{ST} > 0$, add I_{IN} , if $V_{IN} > 5.5\text{ V}$

9) Short circuit current limit for max. duration of $t_{d(SC)}$ max=450 μ s, prior to shutdown

10) Requires 150 Ω resistor in GND connection. The reverse load current through the intrinsic drain-source diode has to be limited by the connected load. Note that the power dissipation is higher compared to normal operating conditions due to the voltage drop across the intrinsic drain-source diode. The temperature protection is not active during reverse current operation! Input and Status currents have to be limited (see max. ratings page 2 and circuit page 6).

11) If a ground resistor R_{GND} is used, add the voltage drop across this resistor.

Truth Table

	Input-level	Output level	Status				
			412 B2	410 D2	410 E2/F2	410 G2	410 H2
Normal operation	L	L	H	H	H	H	H
	H	H	H	H	H	H	H
Open load	L	¹²⁾	L	H	H	H	L
	H	H	H	L	L	L	H
Short circuit to GND	L	L	H	H	H	H	H
	H	L	L	L	L	H	L
Short circuit to V_{bb}	L	H	L	H	H	H	L
	H	H	H	H (L ¹³)	H (L¹³)	H (L ¹³)	H
Overtemperature	L	L	L	L	L	L	L
	H	L	L	L	L	L	L
Under-voltage	L	L	L ¹⁴⁾	L ¹⁴⁾	H	H	H
	H	L	L ¹⁴⁾	L ¹⁴⁾	H	H	H
Overvoltage	L	L	L	L	H	H	H
	H	L	L	L	H	H	H

L = "Low" Level
H = "High" Level

X = don't care

Z = high impedance, potential depends on external circuit

Status signal after the time delay shown in the diagrams (see fig 5. page 11...12)

- ¹²⁾ Power Transistor off, high impedance, versions BTS 410H, BTS 412B: internal pull up current source for open load detection.
- ¹³⁾ Low resistance short V_{bb} to output may be detected in ON-state by the no-load-detection
- ¹⁴⁾ No current sink capability during undervoltage shutdown

Terms

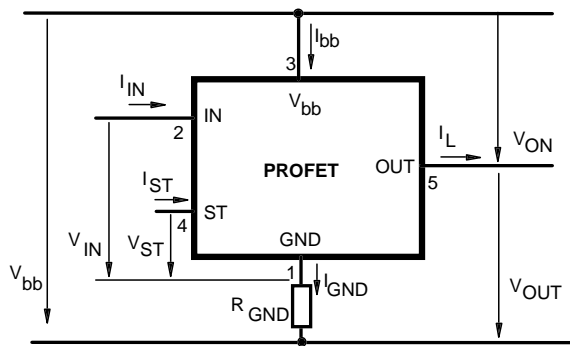

Input circuit (ESD protection)

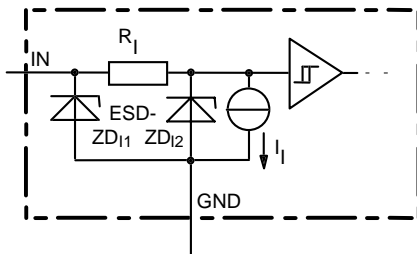

ZD11 6 V typ., ESD zener diodes are not to be used as voltage clamp at DC conditions. Operation in this mode may result in a drift of the zener voltage (increase of up to 1 V).

Status output

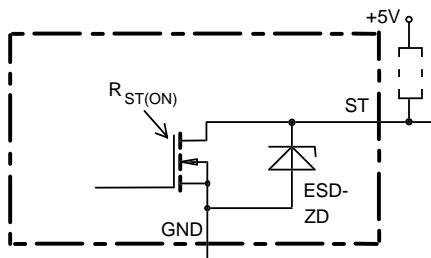

ESD-Zener diode: 6 V typ., max 5 mA;
 $R_{ST(ON)} < 250 \Omega$ at 1.6 mA, ESD zener diodes are not to be used as voltage clamp at DC conditions.
 Operation in this mode may result in a drift of the zener voltage (increase of up to 1 V).

Short circuit detection

Fault Condition: $V_{ON} > 8.5 \text{ V typ.}; I_N \text{ high}$

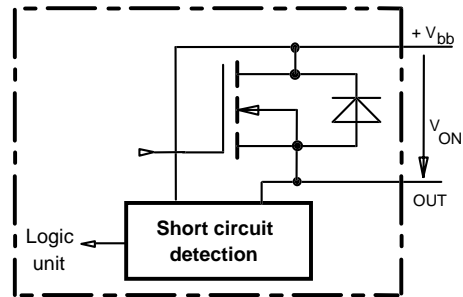

Inductive and overvoltage output clamp

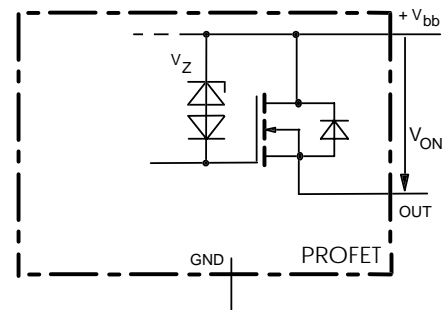

V_{ON} clamped to 68 V typ.

Overvolt. and reverse batt. protection

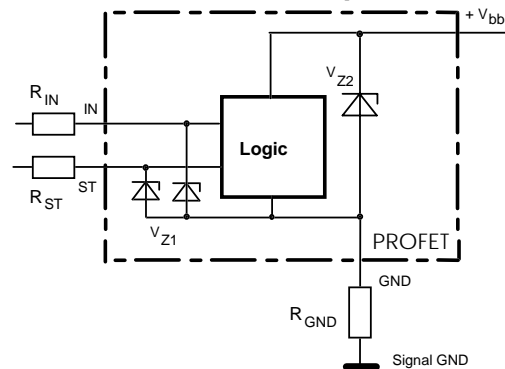

$V_{Z1} = 6.2 \text{ V typ.}, V_{Z2} = 70 \text{ V typ.}, R_{GND} = 150 \Omega, R_{IN}, R_{ST} = 15 \text{ k}\Omega$

Open-load detection

ON-state diagnostic condition: $V_{ON} < R_{ON} \cdot I_{L(OL)}$; IN high

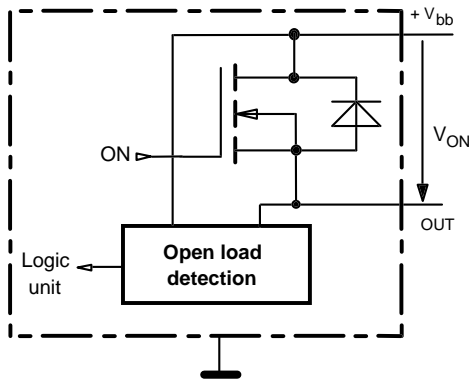

GND disconnect

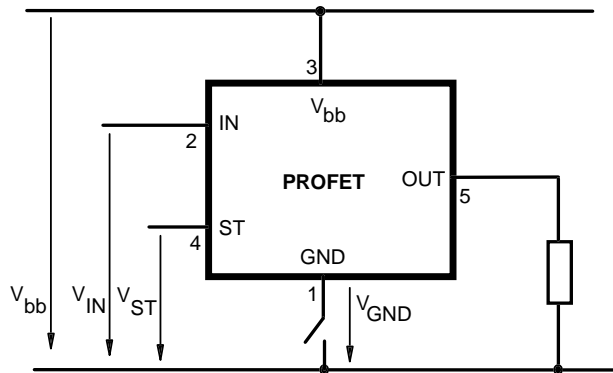

Any kind of load. In case of Input=high is $V_{OUT} = V_{IN} - V_{IN(T+)}$.
Due to $V_{GND} > 0$, no $V_{ST} = \text{low}$ signal available.

GND disconnect with GND pull up

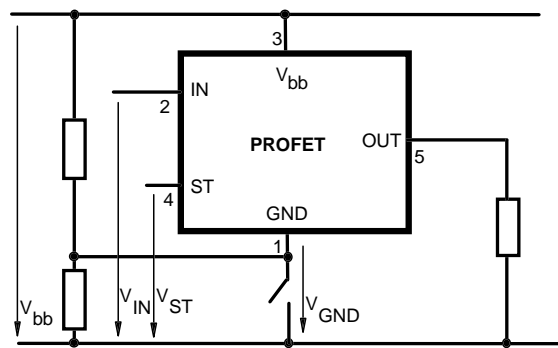

Any kind of load. If $V_{GND} > V_{IN} - V_{IN(T+)}$ device stays off
Due to $V_{GND} > 0$, no $V_{ST} = \text{low}$ signal available.

V_{bb} disconnect with energized inductive load

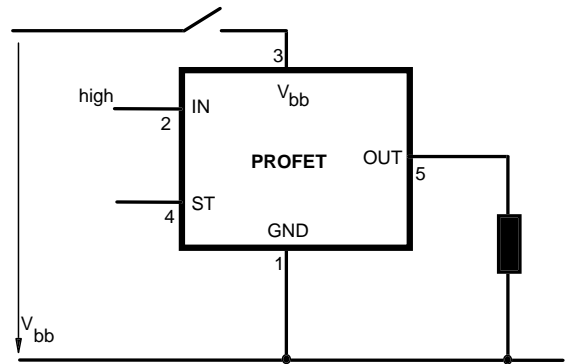

Normal load current can be handled by the PROFET itself.

V_{bb} disconnect with charged external inductive load

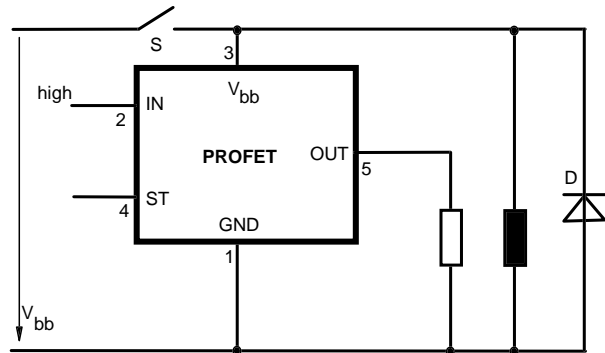

If other external inductive loads L are connected to the PROFET, additional elements like D are necessary.

Inductive Load switch-off energy dissipation

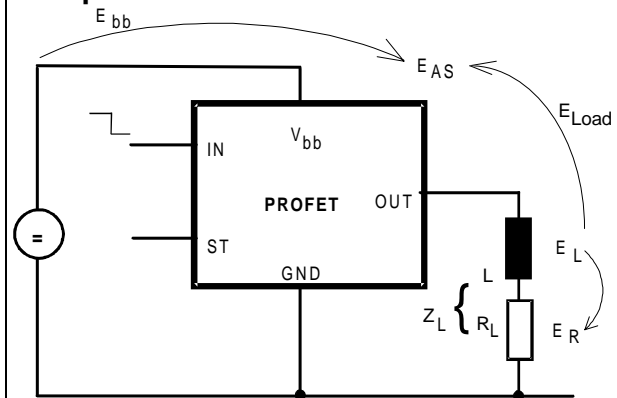

Energy stored in load inductance:

$$E_L = \frac{1}{2} \cdot L \cdot I_L^2$$

While demagnetizing load inductance, the energy dissipated in PROFET is

$$E_{AS} = E_{bb} + E_L - E_R = \int V_{ON(CL)} \cdot I_L(t) dt,$$

with an approximate solution for $R_L > 0 \Omega$:

$$E_{AS} = \frac{I_L \cdot L}{2 \cdot R_L} \cdot (V_{bb} + |V_{OUT(CL)}|) \cdot \ln \left(1 + \frac{I_L \cdot R_L}{|V_{OUT(CL)}|} \right)$$

Maximum allowable load inductance for a single switch off

$L = f(I_L)$; $T_{j,start} = 150^\circ\text{C}$, $T_C = 150^\circ\text{C}$ const.,
 $V_{bb} = 12\text{V}$, $R_L = 0 \Omega$

L [mH]

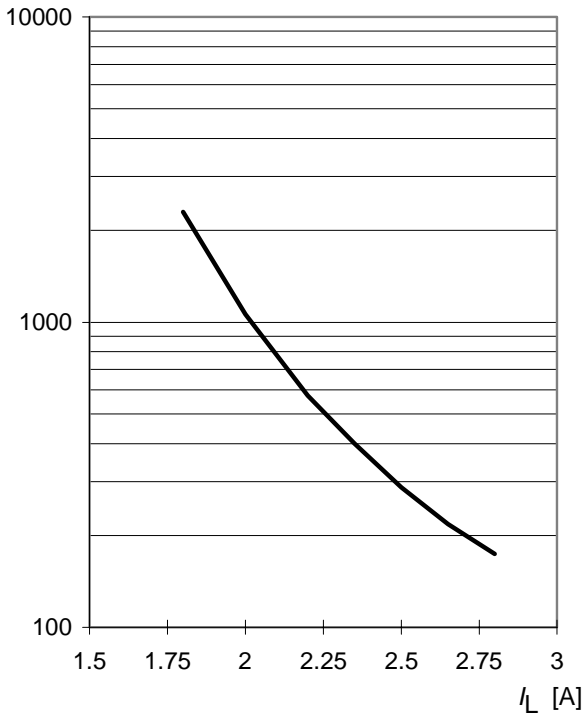

Typ. transient thermal impedance chip case

$Z_{thJC} = f(t_p, D)$, $D = t_p/T$

Z_{thJC} [K/W]

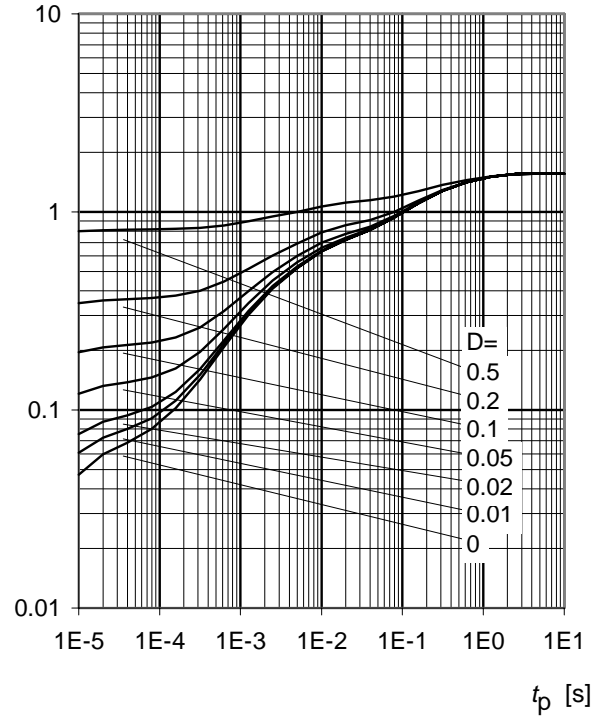

Options Overview

all versions: High-side switch, Input protection, ESD protection, load dump and reverse battery protection with 150 Ω in GND connection, protection against loss of ground

Type	BTS	412 B2	410D2	410E2	410F2	410G2	410H2	307	308
Logic version	B	D	E	F	G	H			
Overtemperature protection with hysteresis $T_j > 150\text{ °C}$, latch function ¹⁵⁾ ¹⁶⁾	X	X		X	X	X	X	X	X
$T_j > 150\text{ °C}$, with auto-restart on cooling			X		X		X		
Short circuit to GND protection switches off when $V_{ON} > 3.5\text{ V}$ typ. and $V_{bb} > 7\text{ V}$ typ ¹⁵⁾ (when first turned on after approx. 150 μs)							X		X
switches off when $V_{ON} > 8.5\text{ V}$ typ. ¹⁵⁾ (when first turned on after approx. 150 μs)	X	X	X	X	X				
Achieved through overtemperature protection						X		X	
Open load detection in OFF-state with sensing current 30 μA typ. in ON-state with sensing voltage drop across power transistor	X		X	X	X	X	X	X	X
Undervoltage shutdown with auto restart	X	X	X	X	X	X	X	X	X
Overvoltage shutdown with auto restart ¹⁷⁾	X	X	X	X	X	X	X	-	X
Status feedback for									
overtemperature	X	X	X	X	X	X	X	X	X
short circuit to GND	X	X	X	X	X	-	X	X	X
short to V_{bb}	X	- ¹⁸⁾	- ¹⁸⁾	- ¹⁸⁾	- ¹⁸⁾	- ¹⁸⁾	X	X	X
open load	X	X	X	X	X	X	X	X	X
undervoltage	X	X	-	-	-	-	-	X	-
overvoltage	X	X	-	-	-	-	-	-	-
Status output type									
CMOS	X	X							
Open drain			X	X	X	X	X	X	X
Output negative voltage transient limit (fast inductive load switch off)									
to $V_{bb} - V_{ON(CL)}$	X	X	X	X	X	X	X	X	X
Load current limit									
high level (can handle loads with high inrush currents)	X	X	X						
low level (better protection of application)				X	X	X	X	X	X
Protection against loss of GND	X	X	X	X	X	X	X	X	X

¹⁵⁾ Latch except when $V_{bb} - V_{OUT} < V_{ON(SC)}$ after shutdown. In most cases $V_{OUT} = 0\text{ V}$ after shutdown ($V_{OUT} \neq 0\text{ V}$ only if forced externally). So the device remains latched unless $V_{bb} < V_{ON(SC)}$ (see page 4). No latch between turn on and $t_{d(SC)}$.

¹⁶⁾ With latch function. Reset by a) Input low, b) Undervoltage

¹⁷⁾ No auto restart after overvoltage in case of short circuit

¹⁸⁾ Low resistance short V_{bb} to output may be detected in ON-state by the no-load-detection

Timing diagrams

Figure 1a: V_{bb} turn on:

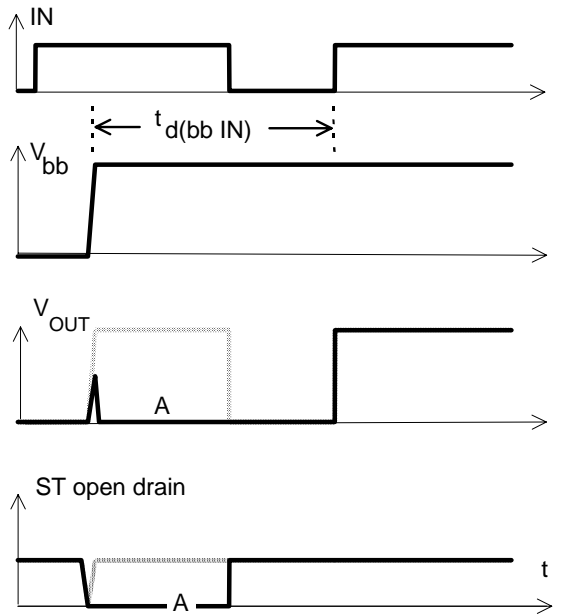

in case of too early V_{IN} =high the device may not turn on (curve A)
 $t_{d(bb IN)}$ approx. 150 μ s

Figure 2a: Switching an inductive load

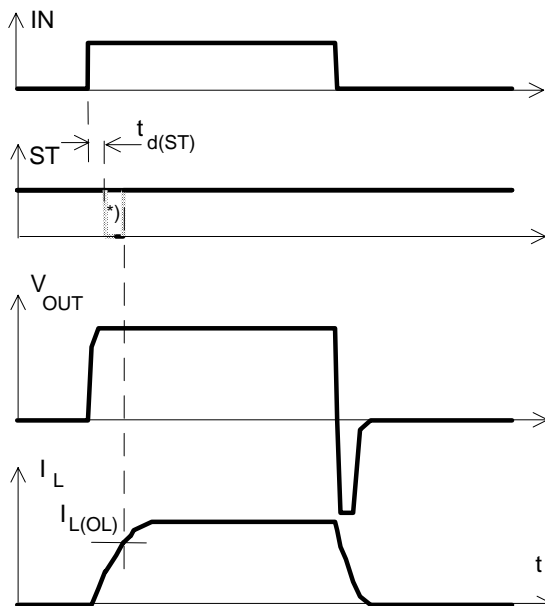

*) if the time constant of load is too large, open-load-status may occur

Figure 3a: Turn on into short circuit,

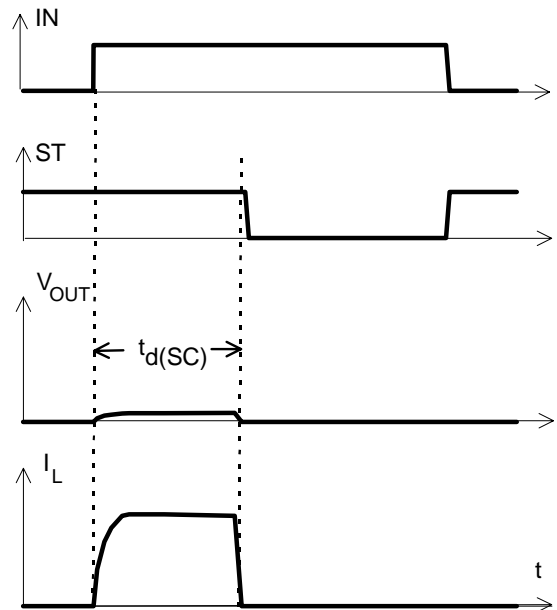

$t_{d(SC)}$ approx. -- μ s if $V_{bb} - V_{OUT} > 8.5$ V typ.

Figure 3b: Turn on into overload,

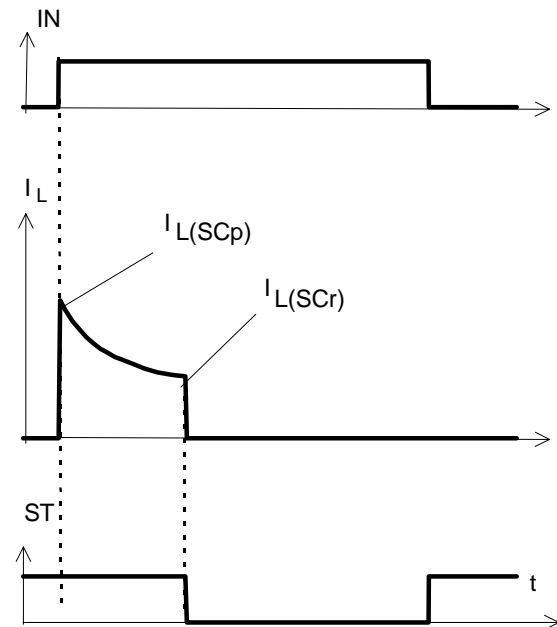

Heating up may require several seconds,
 $V_{bb} - V_{OUT} < 8.5$ V typ.

Figure 3c: Short circuit while on:

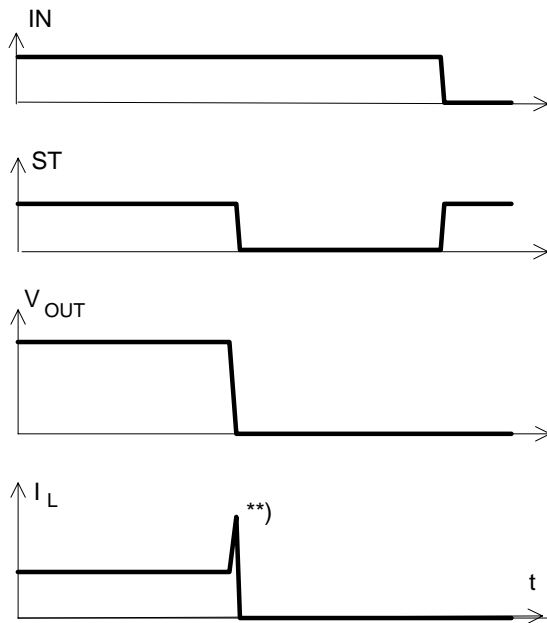

**) current peak approx. 20 μ s

Figure 4a: Overtemperature,

Reset if ($I_N=low$) and ($T_J < T_{jt}$)

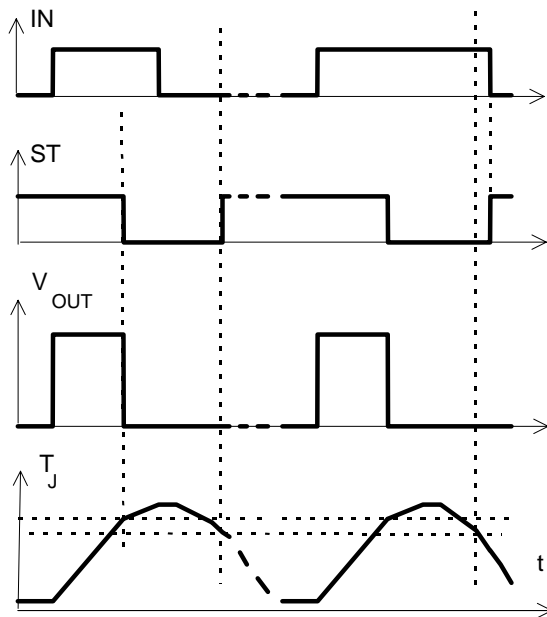

*) ST goes high, when $V_{IN}=low$ and $T_J < T_{jt}$

Figure 5a: Open load: detection in ON-state, turn on/off to open load

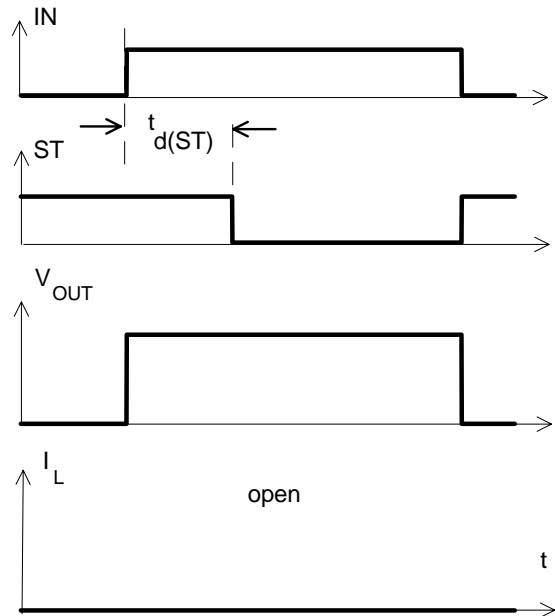
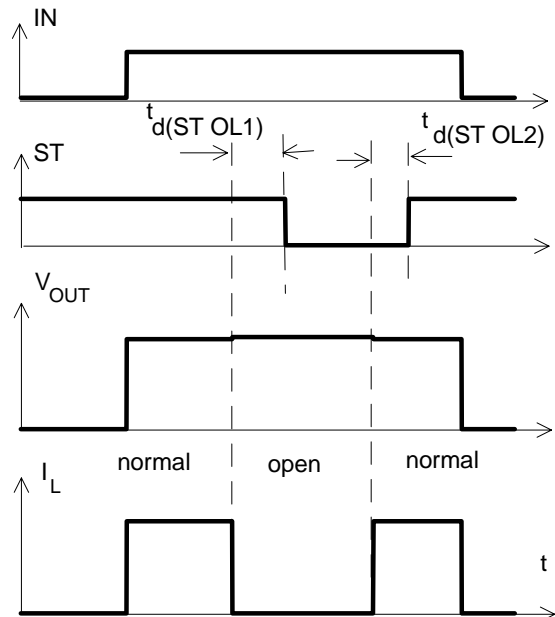

Figure 5b: Open load: detection in ON-state, open load occurs in on-state



$t_{d(ST OL1)} = t_{bd} \mu s$ typ., $t_{d(ST OL2)} = t_{bd} \mu s$ typ

Figure 6a: Undervoltage:

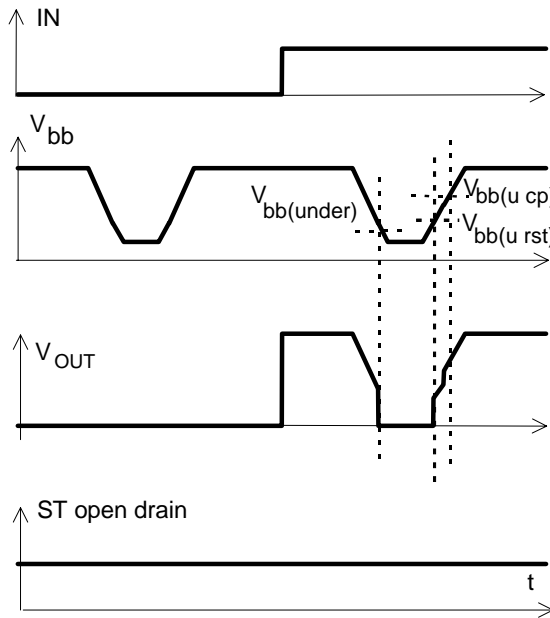

Figure 7a: Overvoltage:

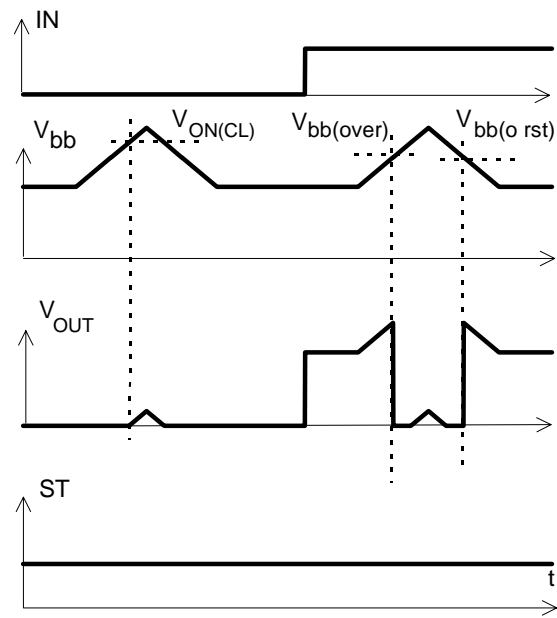
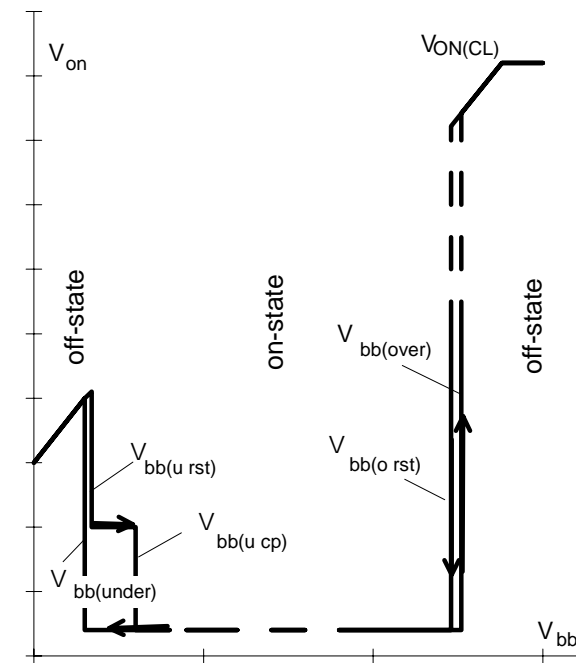
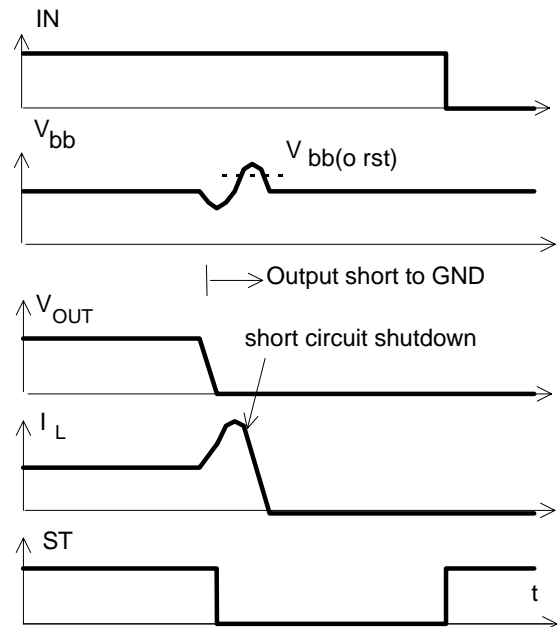

Figure 6b: Undervoltage restart of charge pump



charge pump starts at $V_{bb(ucp)} = 5.6 \text{ V typ.}$

Figure 9a: Overvoltage at short circuit shutdown:



Overvoltage due to power line inductance. No overvoltage auto-restart of PROFET after short circuit shutdown.

Package and Ordering Code

All dimensions in mm

SMD TO-220AB/5, Opt. E3062 Ordering code

BTS410F2 E3062A T&R: Q67060-S6103-A4

Standard TO-220AB/5

Ordering code

BTS 410 F2	Q67060-S6103-A2
------------	-----------------

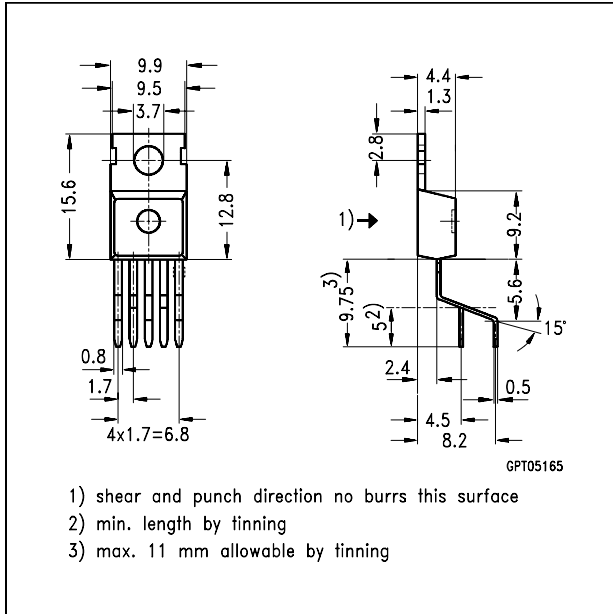

TO-220AB/5, Option E3043 Ordering code

BTS 410 F2 E3043	Q67060-S6103-A3
------------------	-----------------

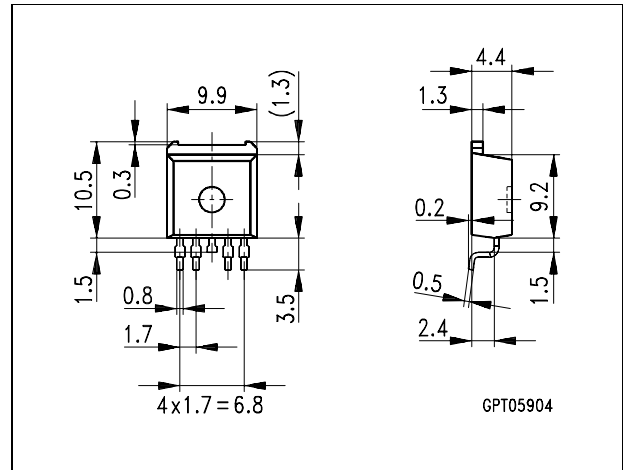
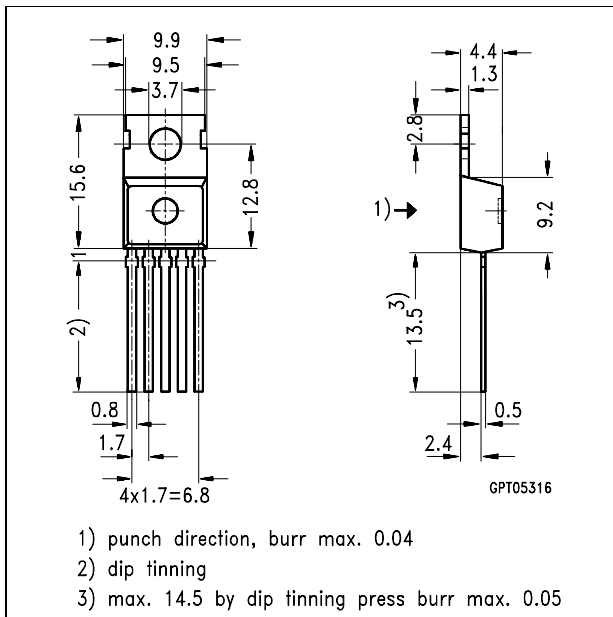

Changed since 04.96

Date	Change
Mar. 1997	E _{AS} maximum rating and diagram and Z _{thJC} diagram added
	ESD capability (except Input) specified to 2kV, R _{thJA} SMD specified
	I _{L(GND high)} max reduced from 10 to 1 mA
	Option Overview table columns for BTS307/308 added
	Fig. 1a: V _{out} -spike at V _{bb} -turn-on added