

ALUMINUM ELECTROLYTIC CAPACITORS

UN series Chip Type, Bi-Polarized, Higher Capacitance Range



- Chip Type, higher capacitance in larger case sizes ($\phi 12.5$, $\phi 16$, $\phi 18$, $\phi 20$)
- Designed for surface mounting on high density PC board.
- Bi-polarized series for operations over wide temperature range of -55 to $+105^{\circ}\text{C}$.
- Applicable to automatic mounting machine fed with carrier tape and tray.
- Compliant to the RoHS directive (2002/95/EC).



Specifications

Item	Performance Characteristics																										
Category Temperature Range	-55 to $+105^{\circ}\text{C}$																										
Rated Voltage Range	6.3 to 100V																										
Rated Capacitance Range	22 to 3300 μF																										
Capacitance Tolerance	$\pm 20\%$ at 120Hz, 20°C																										
Leakage Current	After 1 minute's application of rated voltage, leakage current is not more than $0.03\text{C}\text{V}$ or 4 (μA), whichever is greater.																										
Tangent of loss angle ($\tan \delta$)	Measurement frequency : 120Hz, Temperature : 20°C																										
	<table border="1"> <thead> <tr> <th>Rated voltage (V)</th> <th>6.3</th> <th>10</th> <th>16</th> <th>25</th> <th>35</th> <th>50</th> <th>63</th> <th>100</th> </tr> </thead> <tbody> <tr> <td>$\tan \delta$ (MAX.)</td> <td>0.26</td> <td>0.22</td> <td>0.18</td> <td>0.16</td> <td>0.14</td> <td>0.12</td> <td>0.10</td> <td>0.09</td> </tr> </tbody> </table> <p>For capacitance of more than 1000μF, add 0.02 for every increase of 1000μF.</p>	Rated voltage (V)	6.3	10	16	25	35	50	63	100	$\tan \delta$ (MAX.)	0.26	0.22	0.18	0.16	0.14	0.12	0.10	0.09								
Rated voltage (V)	6.3	10	16	25	35	50	63	100																			
$\tan \delta$ (MAX.)	0.26	0.22	0.18	0.16	0.14	0.12	0.10	0.09																			
Stability at Low Temperature	Measurement frequency: 120Hz																										
	<table border="1"> <thead> <tr> <th>Rated voltage (V)</th> <th>6.3</th> <th>10</th> <th>16</th> <th>25</th> <th>35</th> <th>50</th> <th>63</th> <th>100</th> </tr> </thead> <tbody> <tr> <td>Impedance ratio ZT / Z20 (MAX.)</td> <td>Z-25°C / Z$+20^{\circ}\text{C}$</td> <td>5</td> <td>4</td> <td>3</td> <td>2</td> <td>2</td> <td>2</td> <td>2</td> </tr> <tr> <td></td> <td>Z-40°C / Z$+20^{\circ}\text{C}$</td> <td>10</td> <td>8</td> <td>6</td> <td>4</td> <td>3</td> <td>3</td> <td>3</td> </tr> </tbody> </table>	Rated voltage (V)	6.3	10	16	25	35	50	63	100	Impedance ratio ZT / Z20 (MAX.)	Z -25°C / Z $+20^{\circ}\text{C}$	5	4	3	2	2	2	2		Z -40°C / Z $+20^{\circ}\text{C}$	10	8	6	4	3	3
Rated voltage (V)	6.3	10	16	25	35	50	63	100																			
Impedance ratio ZT / Z20 (MAX.)	Z -25°C / Z $+20^{\circ}\text{C}$	5	4	3	2	2	2	2																			
	Z -40°C / Z $+20^{\circ}\text{C}$	10	8	6	4	3	3	3																			
Endurance	The specifications listed at right shall be met when the capacitors are restored to 20°C after the rated voltage is applied for 2000 hours at 105°C with the polarity inverted every 250 hours.																										
	Capacitance change	Within $\pm 20\%$ of the initial capacitance value																									
	$\tan \delta$	200% or less than the initial specified value																									
Shelf Life	After storing the capacitors under no load at 105°C for 1000 hours and then performing voltage treatment based on JIS C 5101-4 clause 4.1 at 20°C , they shall meet the specified values for the endurance characteristics listed above.																										
		Leakage current	Less than or equal to the initial specified value																								
Marking	Black print on the case top.																										

Chip Type

Type numbering system (Example : 50V 330 μF)

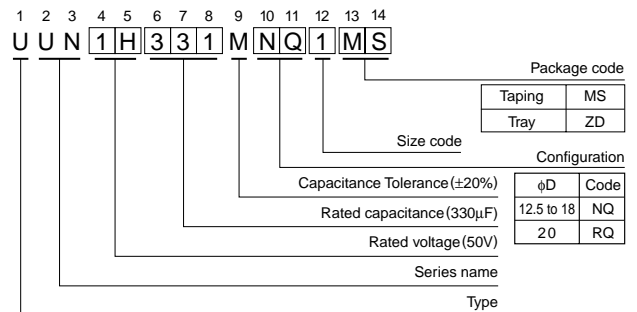
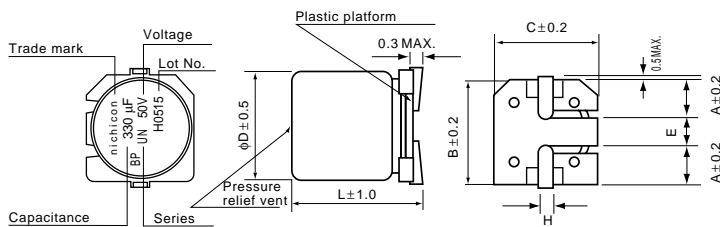

(mm)

	$\phi 12.5 \times 13.5$	12.5×16	16×16.5	16×21.5	18×16.5	18×21.5	20×21.5
A	4.8	4.8	5.4	5.4	6.4	6.4	6.2
B	13.6	13.6	17.1	17.1	19.1	19.1	21.1
C	13.6	13.6	17.1	17.1	19.1	19.1	21.1
E	4.0	4.0	6.3	6.3	6.3	6.3	8.8
L	13.5	16.0	16.5	21.5	16.5	21.5	21.5
H	1.0 to 1.4	1.0 to 1.4	1.0 to 1.4	1.0 to 1.4	1.0 to 1.4	1.0 to 1.4	1.3 to 1.7

● Dimension table in next page.

■ Dimensions

(μF) Cap.	Code	V		6.3		10		16		25		35		50		63		100		
		0J		1A		1C		1E		1V		1H		1J		2A				
22	220																		12.5 × 13.5	100
33	330																		12.5 × 16	150
47	470													12.5 × 13.5	130	12.5 × 13.5	140	16 × 16.5	180	
100	101											12.5 × 13.5	180	12.5 × 16	230	16 × 16.5	270	18 × 21.5	310	
220	221							12.5 × 13.5	270	16 × 16.5	330	18 × 16.5	400	18 × 21.5	440					
330	331					12.5 × 13.5	310	16 × 16.5	370	18 × 16.5	450	18 × 21.5	540	20 × 21.5	590					
470	471	12.5 × 13.5	270	12.5 × 13.5	340	16 × 16.5	420	16 × 16.5	490	18 × 21.5	590	20 × 21.5	640							
1000	102	12.5 × 16	500	16 × 16.5	600	18 × 16.5	670	18 × 21.5	780											
2200	222	18 × 16.5	740	18 × 21.5	830															
3300	332	▲ 16 × 21.5	740	18 × 21.5	920														Case size φ D × L (mm)	Rated ripple

※ In this case, [6] will be put at 12th digit of type numbering system, "▲"

Rated ripple current (mA rms) at 105°C 120Hz

● Frequency coefficient of rated ripple current

Cap.(μF)	Frequency	50 Hz	120 Hz	300 Hz	1 kHz	10 kHz or more
less than 47		0.75	1.00	1.35	1.57	2.00
100 to 470		0.80	1.00	1.23	1.34	1.50
1000 to 3300		0.85	1.00	1.10	1.13	1.15

- Taping specifications are given in page 23.
- Recommended land size, soldering by reflow are given in page 18, 19.
- Please refer to page 3 for the minimum order quantity.