

# Le7942B

## Subscriber Line Interface Circuit



### DISTINCTIVE CHARACTERISTICS

- Programmable constant-current feed
- Receive current gain = 500
- Programmable loop-detect threshold
- Low standby power
- Performs polarity reversal
- Ground-key detector
- Pin for external ground-key noise filter capacitor
- Test relay driver option
- Compatible with Le7942 Device
- Tip Open state for ground-start lines
- -19 V to -58 V battery operation
- Ideal for PBX and KTS applications
- On-chip switching regulator for low-power dissipation
- Can be used with or without the on-chip switching regulator
- On-hook transmission

### BLOCK DIAGRAM

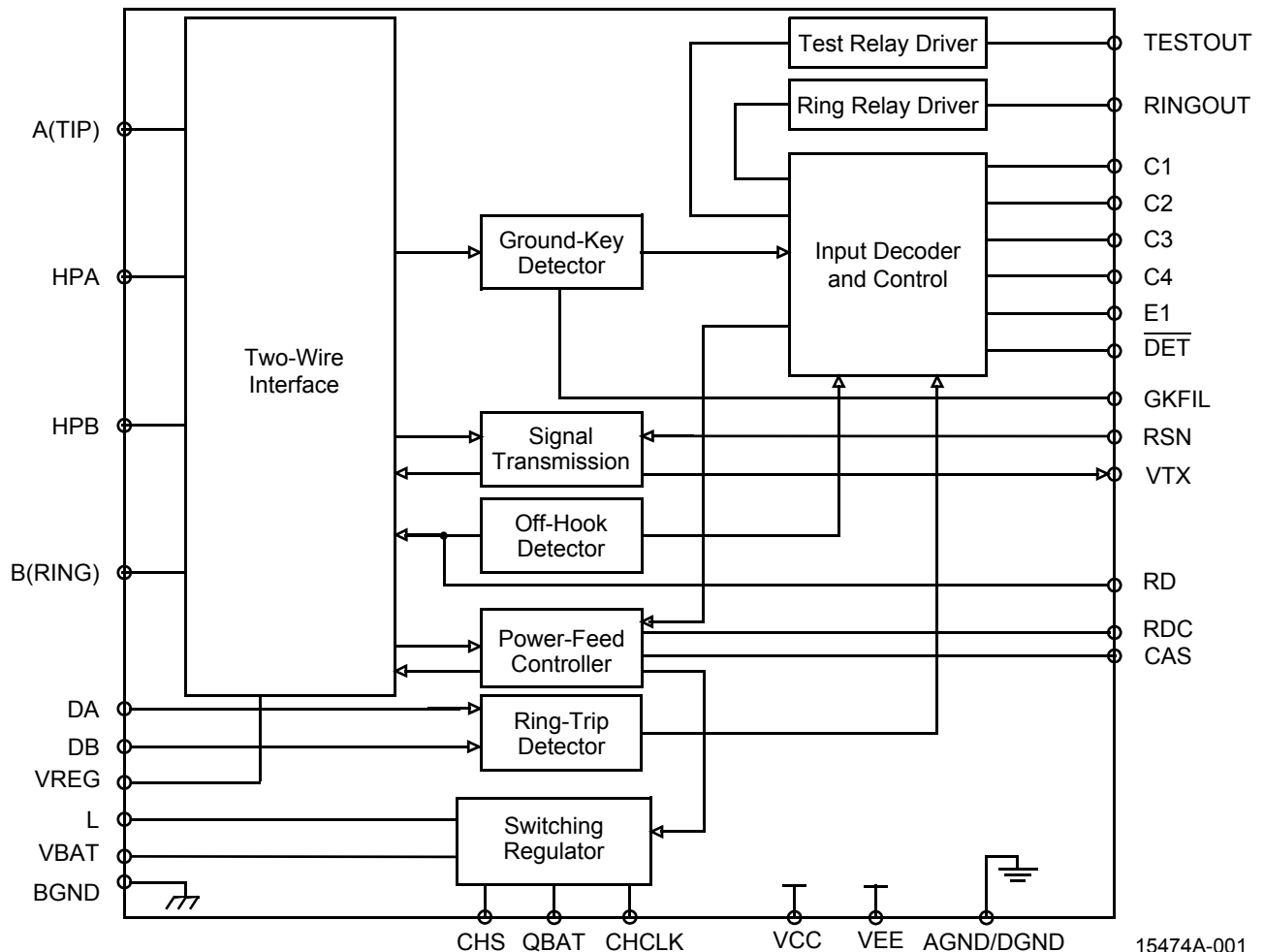

15474A-001

## ORDERING INFORMATION

### Standard Products

Legerity standard products are available in several packages and operating ranges. The order number (Valid Combination) is formed by a combination of the elements below.

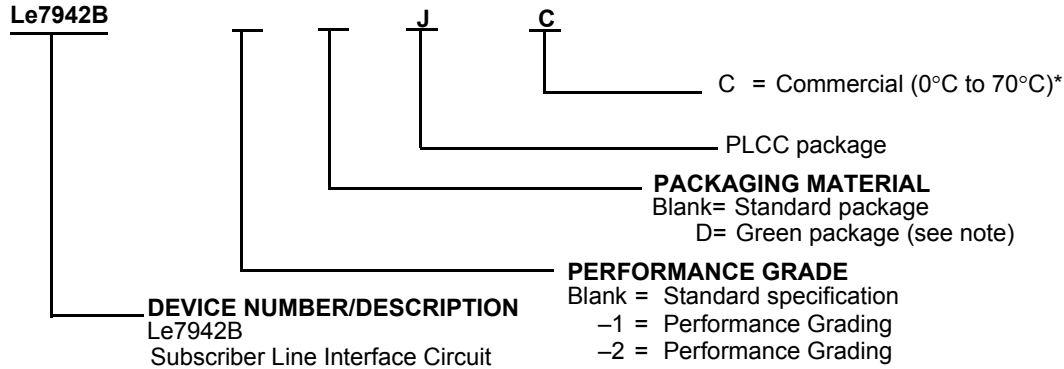

**Note:** The green package meets RoHS Directive 2002/95/EC of the European Council to minimize the environmental impact of electrical equipment.

### Valid Combinations

Valid Combinations
<b>Green Package</b>
Le7942BDJC
Le7942B-1DJC
Le7942B-2DJC
<b>Non-Green Package</b>
Le7942BJC
Le7942B-1JC
Le7942B-2JC

Valid Combinations lists configurations planned to be supported in volume for this device. Consult the local Legerity sales office to confirm availability of specific valid combinations, to check on newly released combinations, and to obtain additional data on Legerity's standard military-grade products.

## CONNECTION DIAGRAMS

### Top View

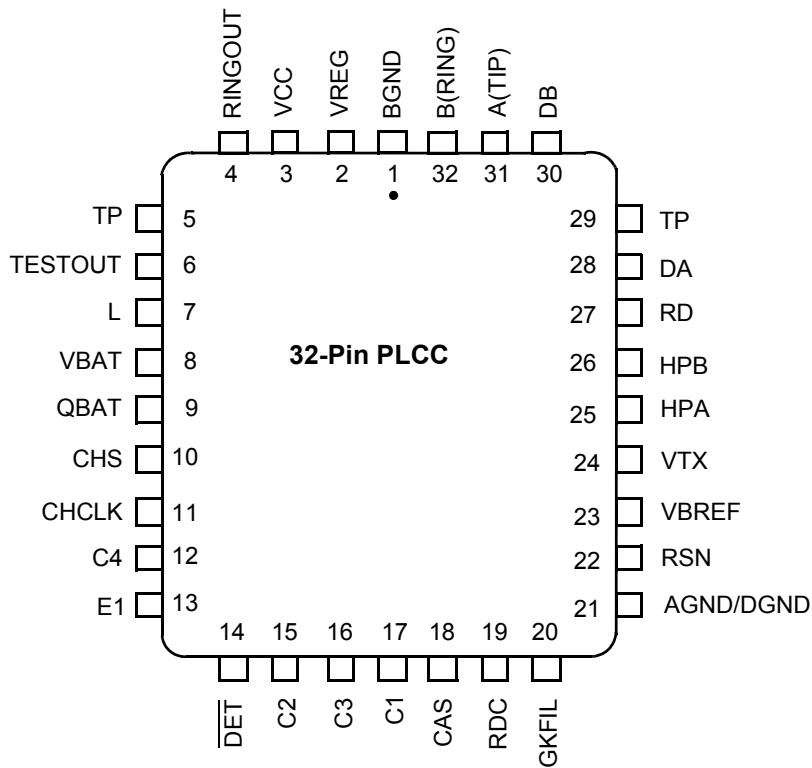

**Notes:**

1. Pin 1 is marked for orientation.
2. TP is a thermal conduction pin tied to substrate (QBAT).

## PIN DESCRIPTIONS

Pin Names	Type	Description
AGND/DGND	Gnd	Analog and Digital ground.
A (TIP)	Output	Output of A(TIP) power amplifier.
BGND	Gnd	Battery (power) ground.
B (RING)	Output	Output of B(RING) power amplifier.
C3–C1	Input	Decoder. TTL compatible. C3 is MSB and C1 is LSB.
C4	Input	Test Relay Driver Command. TTL compatible. A logic Low enables the driver.
CAS	Capacitor	Anti-saturation pin for capacitor to filter reference voltage when operating in anti-saturation region.
CHCLK	Input	Chopper Clock. Input to switching regulator (TTL compatible). Freq = 256 kHz (typ). (See Note 1).
CHS	Input	Chopper Stabilization. (See Note 1) Connection for external chopper stabilizing components.
DA	Input	Ring-trip negative. Negative input to ring-trip comparator.
DB	Input	Ring-trip positive. Positive input to ring-trip comparator.
$\overline{\text{DET}}$	Output	Switchhook detector. When enabled, a logic Low indicates the selected detector is tripped. The detector is selected by the logic inputs (C3–C1, E1). The output is open-collector with a built-in 15 k $\Omega$ pull-up resistor.
E1	Input	Ground-Key Enable. E1 = High connects the ground-key detector to $\overline{\text{DET}}$ . E1 = Low connects the off-hook or ring-trip detector to $\overline{\text{DET}}$ .
GKFIL	—	Connection for external ground-key, noise-filter capacitor. (See Note 2.)
HPA	Capacitor	High-Pass Filter Capacitor. A(TIP) side of high-pass filter capacitor.
HPB	Capacitor	High-Pass Filter Capacitor. B(RING) side of high-pass filter capacitor.
L	Output (See Note 1)	Switching Regulator Power Transistor. Connection point for filter inductor and anode of Switching Regulator Power Transistor. Connection point for filter inductor and anode of catch diode. Has up to 60 V of pulse waveform on it and must be isolated from sensitive circuits. Keep the diode connections short because of the high currents and high di/dt.
QBAT	Battery	Quiet Battery. (See Note 1). Filtered battery supply for the signal processing circuits.
RD	Resistor	Detector resistor. Detector threshold set and filter pin. May be connected to ground or -5V.
RDC	Resistor	DC feed resistor. Connection point for the DC feed current programming network. The other end of the network connects to the receiver summing node (RSN).
RINGOUT	Output	Ring Relay Driver. Open-collector driver with emitter internally connected to BGND. (See Note 3)
RSN	Input	Receive Summing Node. The metallic current (AC and DC) between A(TIP) and B(RING) is equal to 500 x the current into this pin. The networks that program receive gain, two-wire impedance, and feed current all connect to this node.
TESTOUT	Output	Test Relay Driver. Open collector driver with emitter internally connected to BGND. (See Note 3)
TP	Thermal	Thermal pin. Connection for heat dissipation. Internally connected to substrate (QBAT). Leave as open circuit or connected to QBAT. In both cases, the TP pins can connect to an area of copper on the board to enhance heat dissipation.
VBAT	Battery	Battery supply.
VCC	Power	+5 V power supply.
VBREF	Power	Reference voltage. No current on the pin. May be connected to QBAT or -5 V.
VREG	Input	Regulated Voltage. (See Note 1.) Provides negative power supply for power amplifiers. Connection point for inductor, filter capacitor, and chopper stabilization.
VTX	Output	Transmit Audio. This output is a unity gain version of the A(TIP) and B(RING) metallic voltage. VTX also sources the two-wire input impedance programming network.

### Notes:

1. All pins, except CHCLK, connect to VBAT when using SLIC without a switching regulator. CHCLK is connected to AGND/DGND.
2. To prevent noise pickup by the detection circuits when using Ground-Key Detect state (E1 = logical 1), a 3300 pF minimum bypass capacitor is recommended between the GKFIL pin and ground.
3. Each relay driver has a zener clamp to BGND.

## ABSOLUTE MAXIMUM RATINGS

Storage temperature	−55°C to +150°C
$V_{CC}$ with respect to AGND/DGND	−0.4 V to +7.0 V
$V_{EE}$ with respect to AGND/DGND	+0.4 V to QBAT
$V_{BAT}$ with respect to AGND/DGND	+0.4 V to −70 V
<b>Note:</b> Rise time of $V_{BAT}$ ( $dv/dt$ ) must be limited to 27 V/ $\mu$ s or less when $Q_{BAT\ bypass} = 0.33\ \mu$ F.	
BGND with respect to AGND/DGND	+1.0 V to −3.0 V
A(TIP) or B(RING) to BGND:	
Continuous	−70 V to +1.0 V
10 ms ( $f = 0.1$ Hz)	−70 V to +5.0 V
1 $\mu$ s ( $f = 0.1$ Hz)	−90 V to +10 V
250 ns ( $f = 0.1$ Hz)	−120 V to +15 V
Current from A(TIP) or B(RING)	$\pm 150$ mA
Voltage on RINGOUT, TESTOUT	BGND to +7 V
Voltage on RINGOUT, TESTOUT (transient)	BGND to +10 V
Current through relay drivers	60 mA
Voltage on ring-trip inputs (DA and DB)	$V_{BAT}$ to 0 V
Current into ring-trip inputs	$\pm 10$ mA
Peak current into regulator switch (L pin)	150 mA
Switcher transient peak off voltage on L pin	+1.0 V
C4–C1, E1, CHCLK to AGND/DGND	−0.4 V to $V_{CC} + 0.4$ V
Maximum power dissipation, $T_A$ (see note)	70°C
In 32-pin PLCC package	1.74 W

**Note:** Thermal limiting circuitry on chip will shut down the circuit at a junction temperature of about 165°C. The device should never be exposed to this temperature. Operation above 145°C junction temperature may degrade device reliability. See the SLIC Packaging Considerations for more information.

Stresses above those listed under Absolute Maximum Ratings can cause permanent device failure. Functionality at or above these limits is not implied. Exposure to Absolute Maximum Ratings for extended periods may affect device reliability.

## OPERATING RANGES

### Commercial (C) Devices

Ambient temperature	0°C to +70°C*
$V_{CC}$	4.75 V to 5.25 V
$V_{EE}$	−4.75 V to QBAT
$V_{BAT}$	−19 V to −58 V**
AGND/DGND	0 V
BGND with respect to AGND/DGND	−100 mV to +100 mV
Load Resistance on VTX to ground	10 k $\Omega$ min

The Operating Ranges define those limits between which the functionality of the device is guaranteed.

\*Legerity guarantees the performance of this device over commercial (0 to 70°C) and industrial (−40 to 85 °C) temperature ranges by conducting electrical characterization over each range and by conducting a production test with single insertion coupled to periodic sampling. These characterization and test procedures comply with section 4.6.2 of Bellcore TR-TSY-000357 Component Reliability Assurance Requirements for Telecommunications Equipment.

\*\*Can be used without switching regulator components in this range of battery voltages, provided maximum power dissipation specifications are not exceeded.

### Package Assembly

The non-green package devices are assembled with industry-standard mold compounds, and the leads possess a tin/lead (Sn/Pb) plating. These packages are compatible with conventional SnPb eutectic solder board assembly processes. The peak soldering temperature should not exceed 225°C during printed circuit board assembly.

The green package devices are assembled with enhanced environmental compatible lead-free, halogen-free, and antimony-free materials. The leads possess a matte-tin plating which is compatible with conventional board assembly processes or newer lead-free board assembly processes. The peak soldering temperature should not exceed 245°C during printed circuit board assembly.

Refer to IPC/JEDEC J-Std-020B Table 5-2 for the recommended solder reflow temperature profile

## ELECTRICAL CHARACTERISTICS

Description	Test Conditions (See Note 1)	Grade	Min	Typ	Max	Unit	Note
Analog ( $V_{TX}$ ) output impedance		all	3	—		$\Omega$	4
Analog ( $V_{TX}$ ) output offset	0°C to +70°C	-1 -2	-35 -35 -30	—	+35 +35 +30	mV	—
	-40°C to +85°C	-1 -2	-40 -40 -35	—	+40 +40 +35		4
Analog (RSN) input impedance	300 Hz to 3.4 kHz	all	—	1	20	$\Omega$	—
Longitudinal impedance at A or B		all	—	—	35		—
Overload level	4-wire 2-wire	all	-2.5	—	+2.5	Vpk	2
<b>Transmission Performance, 2-Wire Impedance (See Test Circuit D)</b>							
2-wire return loss	300 to 3400 Hz	all	26	—	—	dB	4, 10
<b>Longitudinal Balance (2-Wire and 4-Wire, See Test Circuit C); <math>R_L = 600 \Omega</math></b>							
Longitudinal to metallic L-T, L-4	200 Hz to 1 kHz normal polarity 0°C to +70°C	-1 -2	52 52 63	—	—	dB	1, 2 1, 2, 4 1, 2
	normal polarity -40°C to +85°C reverse polarity	-2 -2	58 54				
	1 kHz to 3.4 kHz normal polarity 0°C to +70°C	-1 -2	52 52 58	—	—		1, 2 1, 2, 4 1, 2
	normal polarity -40°C to +85°C reverse polarity	-2 -2	54 54				
Longitudinal signal generation 4-L	300 Hz to 800 Hz Reverse polarity	-1 -2	40 40 42	—	—		
Longitudinal current capability per wire	Active state OHT state	all	—	28 18	—	mArms	4
<b>Insertion Loss (4- to 2-Wire, See Test Circuit B)</b> <b>BAT = -48 V, <math>R_{LDC} = R_{LAC} = 600 \Omega</math>; BAT = -24 V, <math>R_{LDC} = 300 \Omega</math>, <math>R_{LAC} = 600 \Omega</math></b>							
Gain accuracy	0 dBm, 1 kHz 0°C to +70°C	-1 -2	-0.15 -0.15 -0.10	—	+0.15 +0.15 +0.10	dB	4
	0 dBm, 1 kHz -40°C to +85°C	-1 -2	-0.20 -0.20 -0.15	—	+0.20 +0.20 +0.15		
Variation with frequency	300 Hz to 3400 Hz Relative to 1 kHz 0°C to +70°C	-1 -2	-0.15 -0.15 -0.10	—	+0.15 +0.15 +0.10		4
	300 Hz to 3400 Hz Relative to 1 kHz -40°C to +85°C	-1 -2	-0.20 -0.20 -0.15	—	+0.20 +0.20 +0.15		

## ELECTRICAL CHARACTERISTICS (continued)

Description	Test Conditions (See Note 1)	Grade	Min	Typ	Max	Unit	Note	
Gain tracking	0°C to +70°C +7 dBm to -55 dBm Reference: -0 dBm	all	-0.10	—	+0.10	dB		
	-40°C to +85°C +7 dBm to -55 dBm Reference: -0 dBm	all	-0.15	—	+0.15		4	
<b>Insertion Loss and Balance Return Signal (2- to 4-Wire and 4- to 4-Wire, See Test Circuits A and B)</b> BAT = -48 V, R <sub>LDC</sub> = R <sub>LAC</sub> = 600 Ω; BAT = -24 V, R <sub>LDC</sub> = 300 Ω, R <sub>LAC</sub> = 600 Ω								
Gain accuracy	0 dBm, 1 kHz 0°C to +70°C	-1 -2	-6.17 -6.17 -6.12	-6.02	-5.87 -5.87 -5.92	dB	3 3 3	
	0 dBm, 1 kHz -40°C to +85°C	-1 -2	-6.22 -6.22 -6.17	-6.02	-5.82 -5.82 -5.87		3, 4 3, 4 3, 4	
Variation with frequency	300 Hz to 3400 Hz Relative to 1 kHz 0°C to +70°C	all	-0.10		+0.10	dB	3	
	300 Hz to 3400 Hz Relative to 1 kHz -40°C to +85°C	all	-0.15		+0.15		3, 4	
Gain tracking	0°C to +70°C +3 dBm to -55 dBm Reference: 0 dBm	all	-0.10		+0.10	dB	3	
	-40°C to +85°C +3 dBm to -55 dBm Reference: 0 dBm	all	-0.15		-0.15		3, 4	
Group delay	f = 1 kHz	all		5.3		μs	4, 12	
<b>Total Harmonic Distortion (2- to 4-Wire and 4- to 2-Wire, See Test Circuits A and B)</b> BAT = -48 V, R <sub>LDC</sub> = R <sub>LAC</sub> = 600 Ω								
Harmonic distortion	0 dBm	all		-64	-50	dB		
300 Hz to 3400 Hz	+7 dBm	all		-55	-40		6	
<b>Idle Channel Noise</b> BAT = -48 V, R <sub>LDC</sub> = R <sub>LAC</sub> = 600 Ω; BAT = -24 V, R <sub>LDC</sub> = 300 Ω, R <sub>LAC</sub> = 600 Ω								
C-message weighted noise	2-wire, 0°C to +70°C	all		+7	+10 +12	dBmc	4	
	2-wire, -40°C to +85°C						4	
Psophometric weighted noise	2-wire, 0°C to +70°C	all		-83	-80 -78	dBmp	—	
	2-wire, -40°C to +85°C						4	
<b>Single Frequency Out-of-Band Noise (See Test Circuit E)</b>								
Metallic	4 kHz to 9 kHz	all		-76		dBm	4	
	9 kHz to 1 MHz						-76	4, 5, 8
	256 kHz and harmonics**						-63	4, 5
Longitudinal	1 kHz to 15 kHz	all		-70		dBm	4	
	Above 15 kHz						-85	4, 5, 8
	256 kHz and harmonics**						-57	4, 5
<b>Note:</b> **Applies only when switching regulator is used.								

## ELECTRICAL CHARACTERISTICS (continued)

Description	Test Conditions (See Note 1)	Grade	Min	Typ	Max	Unit	Note
<b>Line Characteristics (See Figures 1a, 1b, 1c)</b>							
Short loops, Active state	$V_{BAT} = -24\text{ V}, R_{LDC} = 300\ \Omega$ $V_{BAT} = -43\text{ V}, R_{LDC} = 600\ \Omega$ $V_{BAT} = -48\text{ V}, R_{LDC} = 600\ \Omega$	all	31.8	34.4	37.0	mA	4, 9 4 —
Long loops, Active state	$V_{BAT} = -24\text{ V}, R_{LDC} = 640\ \Omega$ $V_{BAT} = -43\text{ V}, R_{LDC} = 1300\ \Omega$ $V_{BAT} = -48\text{ V}, R_{LDC} = 1900\ \Omega$	all	20.0 23.0 18.0				4, 9 4 —
OHT state	$V_{BAT} = -24\text{ V}, R_{LDC} = 300\ \Omega$ $V_{BAT} = -48\text{ V}, R_{LDC} = 600\ \Omega$	all	31.4	34.4	37.4		4, 9 —
Loop current	Tip Open state, $R_L = 0\ \Omega$ Disconnect state, $R_L = 0\ \Omega$	all			1.0		
$I_{LIM}$ ( $I_{Tip}$ and $I_{Ring}$ )	Tip and ring shorted to GND	all		70	120		
<b>Power Dissipation Battery, Normal Loop Polarity</b>							
On-hook Open Circuit state	$V_{BAT} = -24\text{ V}$ , w/o switching reg. $V_{BAT} = -48\text{ V}$ , with switching reg.	all		30 35	75 100	mW	9 —
On-hook OHT state	$V_{BAT} = -24\text{ V}$ , w/o switching reg. $V_{BAT} = -48\text{ V}$ , with switching reg.	all		80 130	225		9 —
On-hook Active state	$V_{BAT} = -24\text{ V}$ , w/o switching reg. $V_{BAT} = -48\text{ V}$ , with switching reg.	all		80 130	225 300		9 —
Off-hook OHT state $R_L = 50\ \Omega$	$V_{BAT} = -24\text{ V}$ , w/o switching reg. $V_{BAT} = -48\text{ V}$ , with switching reg.	all		500 400	950 750		9 —
Off-hook Active state $R_L = 50\ \Omega$	$V_{BAT} = -24\text{ V}$ , w/o switching reg. $V_{BAT} = -48\text{ V}$ , with switching reg.	all		800 450	1100 1000		9 —
<b>Supply Currents, Battery = -24 V or -48 V</b>							
$V_{CC}$ on-hook supply current	Open Circuit state OHT state Active state	all		2.5 4.5 4.5	4.5 10.0 12.0	mA	9
$V_{BREF}$ on-hook supply current	Open Circuit state OHT state Active state	all		0 0 0			
$V_{BAT}$ on-hook supply current	Open Circuit state OHT state Active state	all		0.6 2.3 2.3	1.0 5.0 6.0		
<b>Power Supply Rejection Ratio (<math>V_{RIPPLE} = 50\text{ mVrms}</math>)</b>							
$V_{CC}$	50 Hz to 3.4 kHz 3.4 kHz to 50 kHz	all	25 22	45 35		dB	6
$V_{BAT}$	50 Hz to 3.4 kHz 3.4 kHz to 50 kHz	all	27 20	45 40			
Effective int. resistance	CAS to GND	all	85	170	255	k $\Omega$	4
<b>Off-Hook Detector</b>							
Current threshold	$I_{DET} = 365/R_D$ If $R_D$ to gnd $I_{DET} = 1825/R_D$ If $R_D$ to -5V	all	-20		+20	%	



## ELECTRICAL CHARACTERISTICS (continued)

Description	Test Conditions (See Note 1)	Grade	Min	Typ	Max	Unit	Note
<b>Ground-Key Detector Thresholds, Active State</b>							
Ground-key resistance threshold	$V_{BAT} = -24\text{ V}$ , B(RING) to GND $V_{BAT} = -48\text{ V}$ , B(RING) to GND	all	1.0 2.0	2.2 5.0	4.5 10.0	k $\Omega$	9 —
Ground-key current threshold	B(RING) to GND Midpoint to GND	all		9 9		mA	7
Effective internal resistance	GKFIL to AGND/DGND	all	18	36	54	k $\Omega$	4
<b>Ring-Trip Detector Input</b>							
Bias current		all	-5	-0.05		$\mu\text{A}$	
Offset voltage	Source resistance = 0 to 2 M $\Omega$	all	-50	0	+50	mV	11
<b>Logic Inputs (C4–C1, E1, and CHCLK)</b>							
Input High voltage		all	2.0			V	
Input Low voltage		all			0.8		
Input High current	All inputs except E1	all	-75		40	$\mu\text{A}$	
Input High current	Input E1	all	-75		45		
Input Low current		all	-0.4			mA	
<b>Logic Output (<math>\overline{\text{DET}}</math>)</b>							
Output Low voltage	$I_{OUT} = 0.3\text{ mA}$	all			0.4	V	
Output High voltage	$I_{OUT} = -0.1\text{ mA}$	all	2.4				
<b>Relay Driver Outputs (RINGOUT, TESTOUT)</b>							
On voltage	25 mA sink	all		0.3	+1.5	V	
Off leakage	$V_{OH} = 5\text{ V}$	all			100	$\mu\text{A}$	
Zener break-over	$I_L = 100\ \mu\text{A}$	all	6	7.2		V	
Zener on voltage	$I_L = 30\text{ mA}$	all		8			

## RELAY DRIVER SCHEMATICS

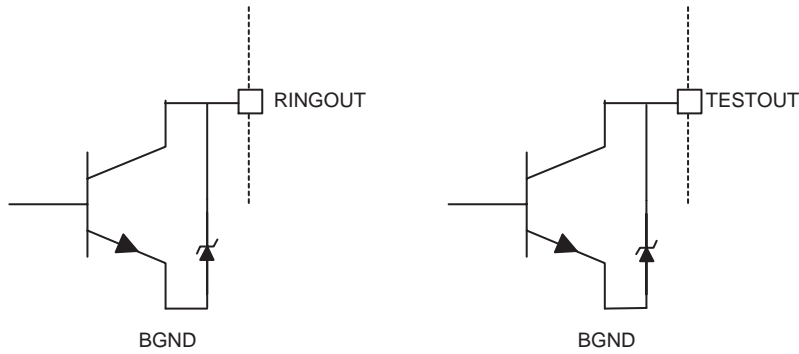

## SWITCHING CHARACTERISTICS

Symbol	Parameter	Test Conditions	Temperature Range	Min	Typ	Max	Unit	Note
tgkde	E1 Low to $\overline{\text{DET}}$ High (E0 = 1)	Ground-Key Detect state $R_L$ open, $R_G$ connected (See Figure H)	0°C to +70°C -40°C to +85°C			3.8		
	E1 Low to $\overline{\text{DET}}$ Low (E0 = 1)					1.1 1.6		
tshde	E1 High to $\overline{\text{DET}}$ Low (E0 = 1)	Switchhook Detect state $R_L = 600 \Omega$ , $R_G$ open (See Figure G)	0°C to +70°C -40°C to +85°C			1.2		
	E1 High to $\overline{\text{DET}}$ High (E0 = 1)					3.8 4.0		

## SWITCHING WAVEFORMS

E1 to  $\overline{\text{DET}}$

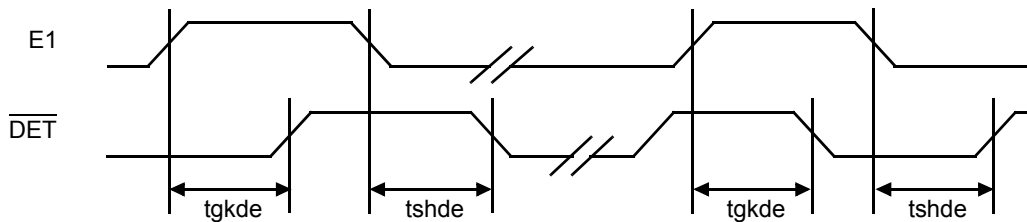

**Note:**

All delays measured at 1.4 V levels.

15474A-003

**Notes:**

1. Unless otherwise noted, test conditions are  $BAT = -48\text{ V}$ ,  $V_{CC} = +5\text{ V}$ ,  $R_L = 600\ \Omega$ ,  $C_{HP} = 0.33\ \mu\text{F}$ ,  $R_{DC1} = R_{DC2} = 9.09\ \text{k}\Omega$ ,  $C_{DC} = 0.39\ \mu\text{F}$ ,  $R_D = 35.4\ \text{k}\Omega$  when  $R_D$  is connected to ground and  $R_D = 177\ \text{k}\Omega$  when  $R_D$  is connected to  $-5\text{ V}$ .  $C_{CAS} = 0.47\ \mu\text{F}$ , no fuse resistors,  $R_T = 150\ \text{k}\Omega$ , and  $R_{RX} = 150\ \text{k}\Omega$ . Switching regulator components:  $L = 1\ \text{mH}$ ,  $C_{FIL} = 0.47\ \mu\text{F}$  (see Application Circuit).
2. Overload level is defined when  $THD = 1\%$ .
3. Balance return signal is the signal generated at  $V_{TX}$  by  $V_{RX}$ . This specification assumes the two-wire AC load impedance matches the programmed impedance.
4. Not tested in production. This parameter is guaranteed by characterization or correlation to other tests.
5. For frequencies below 12 kHz, these tests are performed with a longitudinal impedance of  $90\ \Omega$  and metallic impedance of  $300\ \Omega$ . For frequencies greater than 12 kHz, a longitudinal impedance of  $90\ \Omega$  and a metallic impedance of  $135\ \Omega$  is used. These tests are extremely sensitive to circuit board layout. Please refer to application notes for details.
6. This parameter is tested at 1 kHz in production. Performance at other frequencies is guaranteed by characterization.
7. "Midpoint" is defined as the connection point between two  $300\ \Omega$  series resistors connected between A(TIP) and B(RING).
8. Fundamental and harmonics from 256 kHz switch regulator chopper are not included.
9. For  $-24\ \text{V}$  battery, switching regulator is disabled. L, CHS, and VREG pins connected to VBAT pin; CHCLK pin connected to AGND/DGND.
10. Assumes the following  $Z_T$  network:

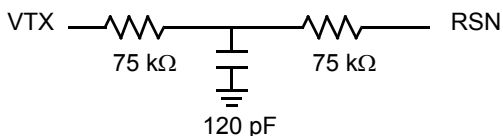

11. Tested with  $0\ \Omega$  source impedance.  $2\ \text{M}\Omega$  is specified for system design purposes only.
12. Group delay can be considerably reduced by using a  $Z_T$  network such as that shown in Note 10 above. The network reduces the group delay to less than  $2\ \mu\text{s}$ . The effect of group delay on linecard performance may be compensated for by using the QSLAC™ or DSLAC™ device.

**Table 1. SLIC Device Decoding**

State	C3 C2 C1	Two-Wire Status	DET Output	
			E1 = 0	E1 = 1
0	0 0 0	Open Circuit	Ring trip	Ring trip
1	0 0 1	Ringing	Ring trip	Ring trip
2	0 1 0	Active	Loop detector	Ground key
3	0 1 1	On-Hook TX (OHT)	Loop detector	Ground key
4	1 0 0	Tip Open	Loop detector	—
5	1 0 1	Reserved	Loop detector	—
6	1 1 0	Active Polarity Reversal	Loop detector	Ground key
7	1 1 1	OHT Polarity Reversal	Loop detector	Ground key

**Table 2. User-Programmable Components**

$Z_T = 250(Z_{2WIN} - 2R_F^*)$	<p><math>Z_T</math> is connected between the VTX and RSN pins. The fuse resistors are <math>R_F</math>, and <math>Z_{2WIN}</math> is the desired 2-wire AC input impedance. When computing <math>Z_T</math>, the internal current amplifier pole and any external stray capacitance between VTX and RSN must be taken into account.</p>
$Z_{RX} = \frac{Z_L}{G_{42L}} \bullet \frac{500Z_T}{Z_T + 250(Z_L + 2R_F)}$	<p><math>Z_{RX}</math> is connected from <math>V_{RX}</math> to the <math>R_{SN}</math>. <math>Z_T</math> is defined above, and <math>G_{42L}</math> is the desired receive gain.</p>
$R_{DC1} + R_{DC2} = \frac{625}{I_{LOOP}}$ $C_{DC} = 1.5 \text{ ms} \bullet \frac{R_{DC1} + R_{DC2}}{R_{DC1} R_{DC2}}$	<p><math>R_{DC1}</math>, <math>R_{DC2}</math>, and <math>C_{DC}</math> form the network connected to the RDC pin. <math>R_{DC1}</math> and <math>R_{DC2}</math> are approximately equal. <math>I_{LOOP}</math> is the desired loop current in the constant-current region.</p>
$R_D = \frac{365}{I_T} \quad \text{If } R_D \text{ is connected to ground.}$ $R_D = \frac{1825}{I_T} \quad \text{If } R_D \text{ is connected to -5V.}$ $C_D = \frac{0.5 \text{ ms}}{R_D}$	<p><math>R_D</math> and <math>C_D</math> form a network connected from RD to either ground or -5 V, and <math>I_T</math> is the threshold current between on hook and off hook.</p>
$C_{CAS} = \frac{1}{3.4 \bullet 10^5 \pi f_c}$	<p><math>C_{CAS}</math> is the regulator filter capacitor, and <math>f_c</math> is the desired filter cut-off frequency.</p>

**Note:**

\* $R_{FUSE} = 20 - 50 \Omega$ , user selectable.

## DC FEED CHARACTERISTICS

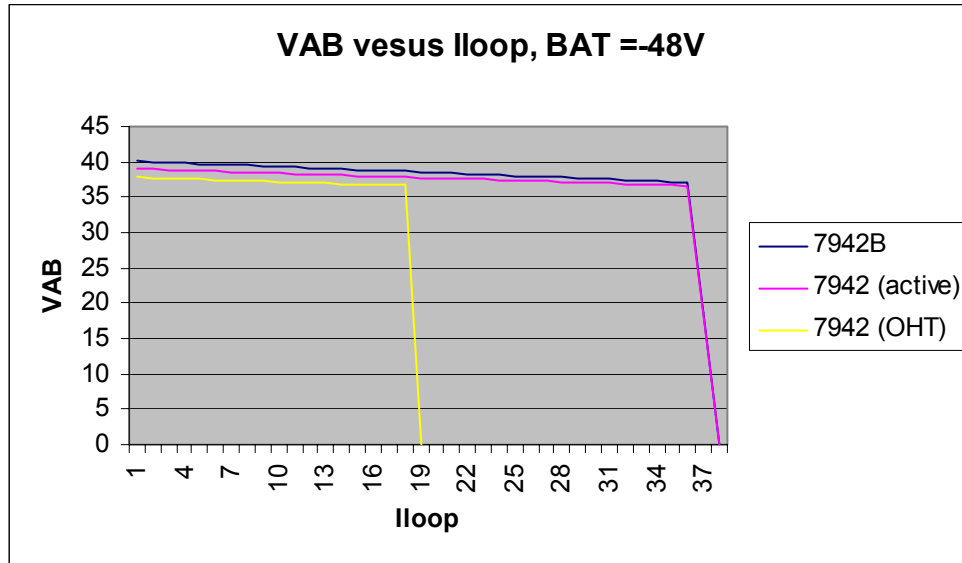

$$R_{DC1} + R_{DC2} = R_{DC} = 18.18 \text{ k}\Omega$$

———— Active state  
 - - - - - OHT state

**Notes:**

1. Constant-current region:

Active state: 
$$I_L = \frac{625}{R_{DC}}$$

OHT state: 
$$I_L = \frac{625}{R_{DC}}$$

2. Anti-saturation 2 region:

Active state:  
 and  
 OHT state: 
$$V_{AB} = |BAT| - 7.9 - I_L \left( \frac{R_{DC}}{210} \right)$$

a.  $V_A - V_B$  ( $V_{AB}$ ) Voltage vs. Loop Current (Typical)

## DC FEED CHARACTERISTICS (continued)

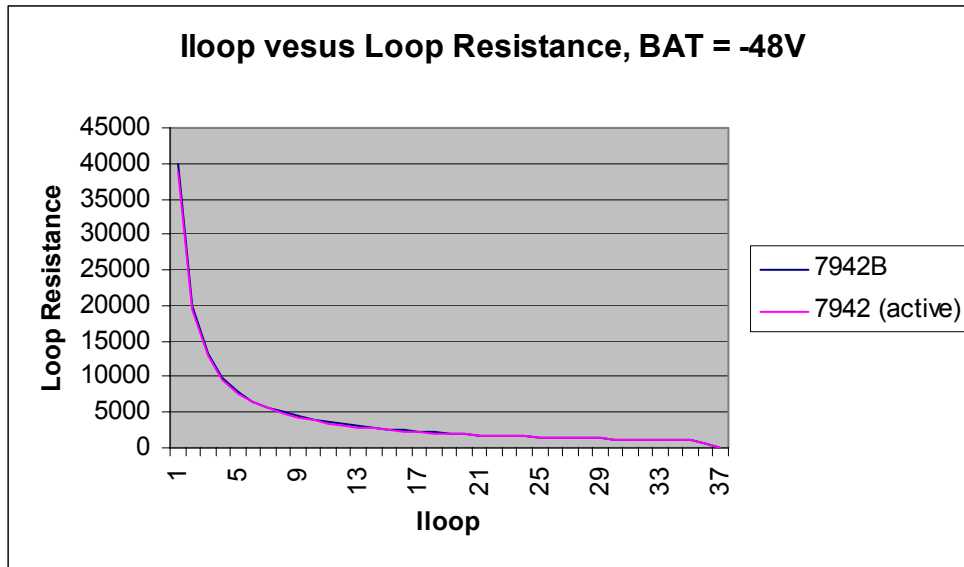

$$R_{DC1} + R_{DC2} = R_{DC} = 18.18 \text{ k}\Omega$$

### b. Loop Current vs. Load Resistance (Typical)

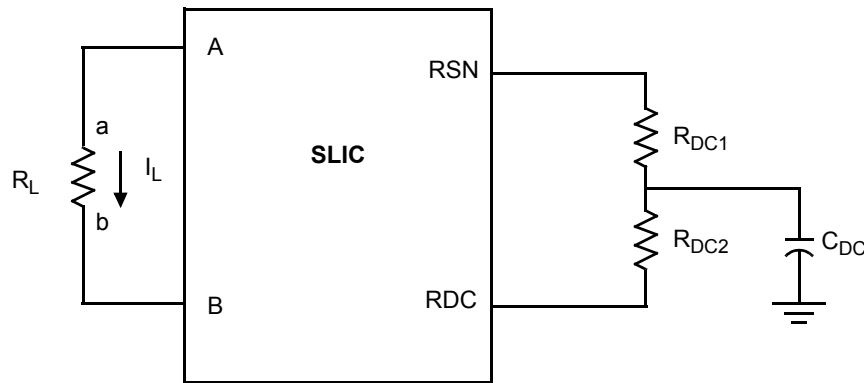

Feed current programmed by  $R_{DC1}$  and  $R_{DC2}$

### c. Feed Programming

15474A-004

Figure 1. DC Feed Characteristics

## TEST CIRCUITS

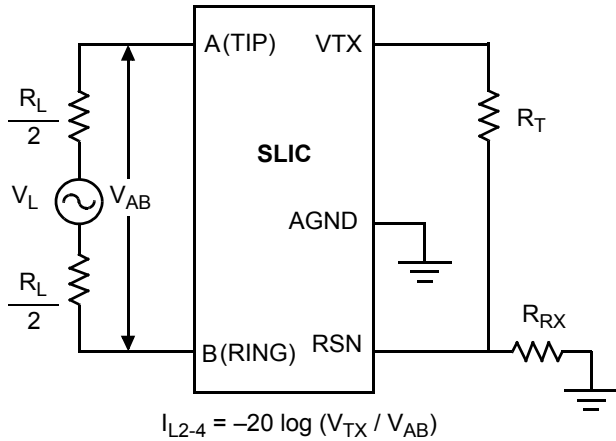

**A. Two- to Four-Wire Insertion Loss**

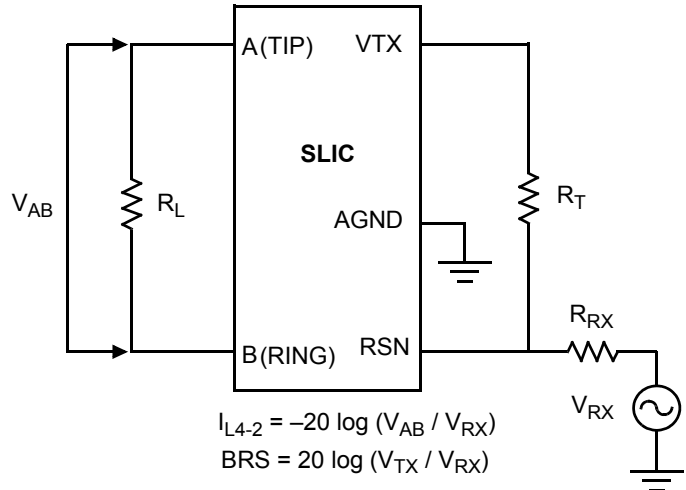

**B. Four- to Two-Wire Insertion Loss and Balance Return Signal**

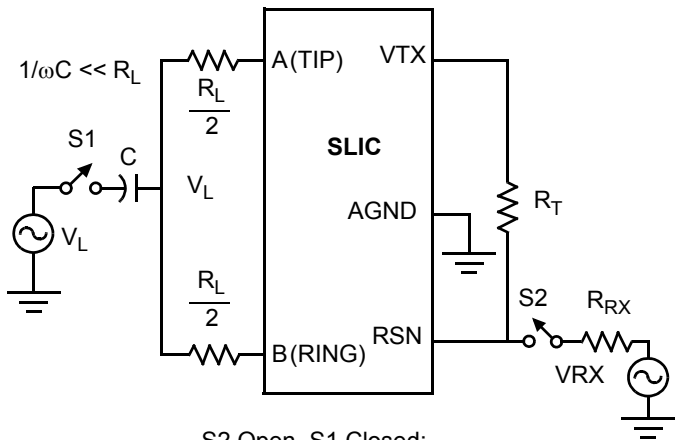

S2 Open, S1 Closed:

L-T Long. Bal. =  $20 \log (V_{AB} / V_L)$

L-4 Long. Bal. =  $20 \log (V_{TX} / V_L)$

S2 Closed, S1 Open:

4-L Long. Sig. Gen. =  $20 \log (V_L / V_{RX})$

**C. Longitudinal Balance**

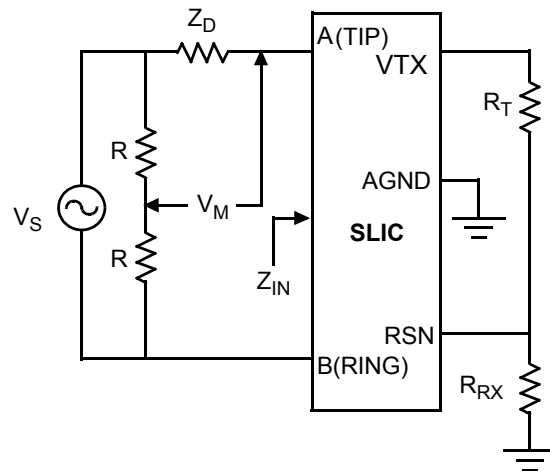

**Note:**

$Z_D$  is the desired impedance (e.g., the characteristic impedance of the line).

$R_L = -20 \log (2 V_M / V_S)$

**D. Two-Wire Return Loss Test Circuit**

**TEST CIRCUITS (continued)**

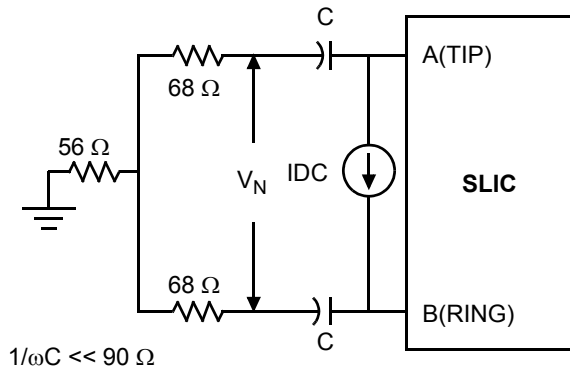

**E. Single-Frequency Noise**

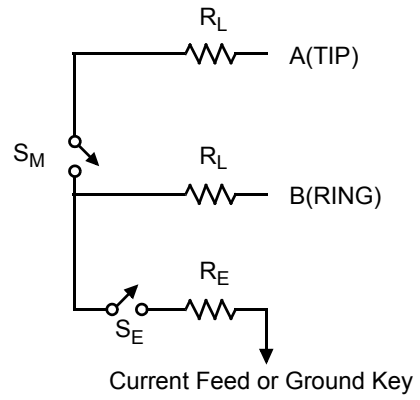

**F. Ground-Key Detection Center Point Test**

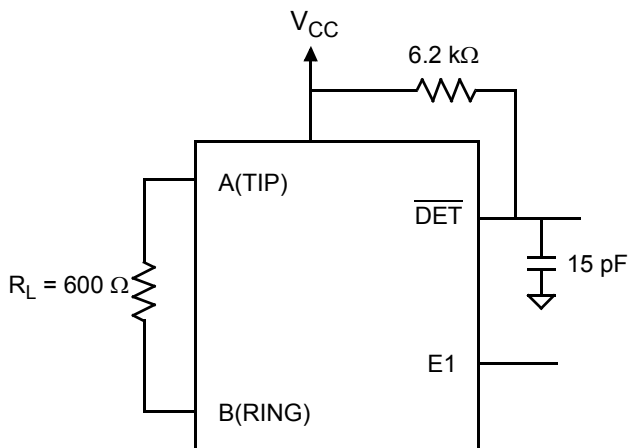

**G. Loop-Detector Switching**

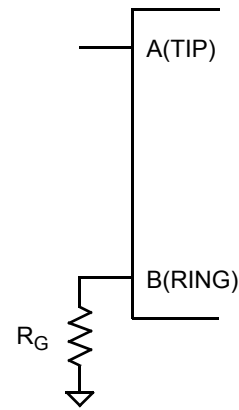

$R_G: 2 \text{ k}\Omega \text{ at } V_{BAT} = -48 \text{ V}$   
 $1 \text{ k}\Omega \text{ at } V_{BAT} = -24 \text{ V}$

**H. Ground-Key Switching**



# PHYSICAL DIMENSIONS

## 32-Pin PLCC

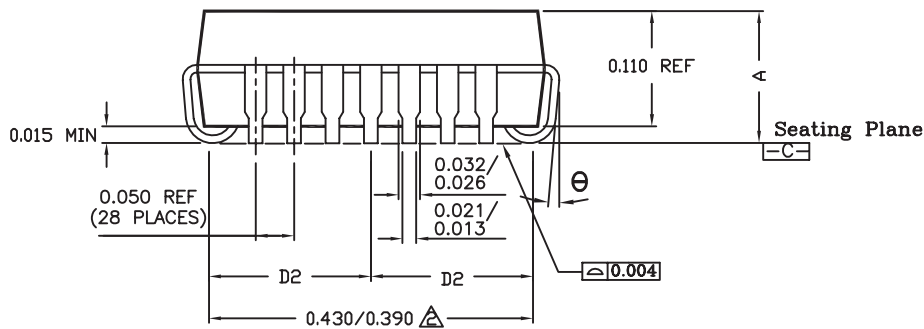
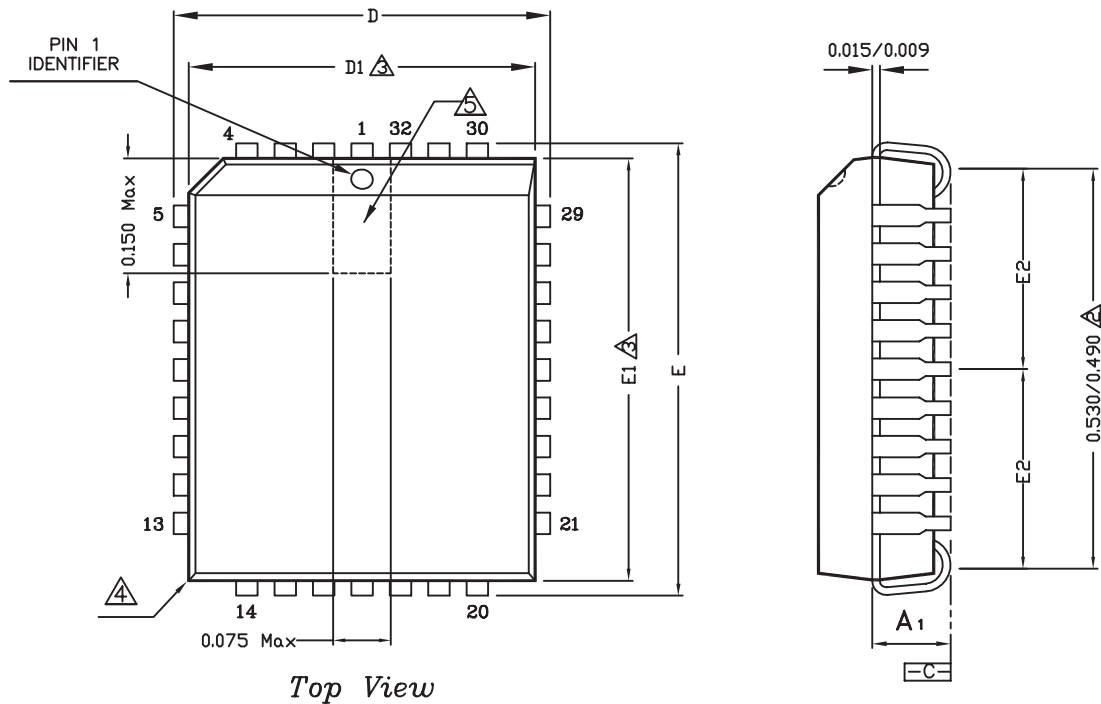

NOTE :

1. DIMENSIONING AND TOLERANCING CONFORM TO ASME Y14.5M-1994.
- △ TO BE MEASURED AT SEATING PLANE  $\boxed{C}$  CONTACT POINT.
- △ DIMENSIONS D1 AND E1 DO NOT INCLUDE MOLD PROTUSION. ALLOWABLE MOLD PROTUSION IS 0.010 IN PER SIDE. DIMENSIONS D, AND E, INCLUDE MOLD MISMATCH AND DETERMINED AT THE PARTING LINE; THAT IS D1 AND E1 ARE MEASURED AT THE EXTREME MATERIAL CONDITION AT THE UPPER OR LOWER PARTING LINE.
- △ EXACT SHAPE OF THIS FEATURE IS OPTIONAL.
- △ DETAILS OF PIN 1 IDENTIFIER ARE OPTIONAL BUT MUST BE LOCATED WITHIN THE ZONE INDICATED.
6. SUM OF DAM BAR PROTUSIONS TO BE 0.007 MAX PER LEAD.
7. CONTROLLING DIMENSION : INCH.
8. REFERENCE DOCUMENT : JEDEC MS-016

Symbol	Dimension in inch		
	Min	Nom	Max
A	0.125	—	0.140
A1	0.075	0.090	0.095
D	0.485	0.490	0.495
D1	0.447	0.450	0.453
D2	0.205 REF		
E	0.585	0.590	0.595
E1	0.547	0.550	0.553
E2	0.255 REF		
θ	0°	—	10°

---

## REVISION HISTORY

### Revision A1 to B1

- Page 12, modified ZRX equation.

### Revision B1 to C1

- Page 8, Line characteristics, OHT State,  $V_{BAT} = -24\text{ V}$ ,  $R_{LDC} = 600\ \Omega$  to  $R_{LDC} = 300\ \Omega$ .
- Page 8, Power Dissipation, Off-hook OHT state  $R_L = 50\ \Omega$ ,  $V_{BAT} = -24\text{ V}$ , w/o switching reg., max 800mW to 950mW.

### Revision C1 to D1

- Page 8, Line characteristics,  $I_{LIM}$  ( $I_{Tip}$  and  $I_{Ring}$ ), changed Max value from 105 to 120.

### Revision D1 to E1

- Added green package OPN
- Added *Package Assembly* section

The contents of this document are provided in connection with Legerity, Inc. products. Legerity makes no representations or warranties with respect to the accuracy or completeness of the contents of this publication and reserves the right to make changes to specifications and product descriptions at any time without notice. No license, whether express, implied, arising by estoppel or otherwise, to any intellectual property rights is granted by this publication. Except as set forth in Legerity's Standard Terms and Conditions of Sale, Legerity assumes no liability whatsoever, and disclaims any express or implied warranty, relating to its products including, but not limited to, the implied warranty of merchantability, fitness for a particular purpose, or infringement of any intellectual property right.

Legerity's products are not designed, intended, authorized or warranted for use as components in systems intended for surgical implant into the body, or in other applications intended to support or sustain life, or in any other application in which the failure of Legerity's product could create a situation where personal injury, death, or severe property or environmental damage may occur. Legerity reserves the right to discontinue or make changes to its products at any time without notice.

**© 2005 Legerity, Inc.**  
All rights reserved.

#### **Trademarks**

Legerity, the Legerity logo and combinations thereof, and QSLAC, DSLAC, are trademarks of Legerity, Inc.

Other product names used in this publication are for identification purposes only and may be trademarks of their respective companies.



4509 Freidrich Lane  
Austin, Texas 78744-1812

Telephone: (512) 228-5400  
Fax: (512) 228-5508  
North America Toll Free: (800) 432-4009

To find the Legerity Sales Office nearest you, visit our website at:

<http://www.legerity.com/sales>

or email:

[sales@legerity.com](mailto:sales@legerity.com)

To download or order data sheets, application notes, or evaluation tools, go to:

[www.legerity.com/support](http://www.legerity.com/support)

For all other technical inquiries, please contact Legerity Tech Support at:

[techsupport@legerity.com](mailto:techsupport@legerity.com)

or call +1 512.228.5400.