

Le7920

Subscriber Line Interface Circuit



The Le7920 Subscriber Line Interface Circuit implements the basic telephone line interface

functions, and enables the design of low cost, high performance, POTS line interface cards.

DISTINCTIVE CHARACTERISTICS

- Control states: Active, Ringing, Standby, and Disconnect
- Low standby power (35 mW)
- -19 V to -58 V battery operation
- On-hook transmission
- Two-wire impedance set by single external impedance
- Programmable constant-current feed
- Programmable loop-detect threshold
- Programmable ring-trip detect threshold
- No -5 V supply required
- Current Gain = 500
- On-chip Thermal Management (TMG) feature
- Four on-chip relay drivers and relay snubbers, 1 ringing and 3 general purpose (32 PLCC)

BLOCK DIAGRAM

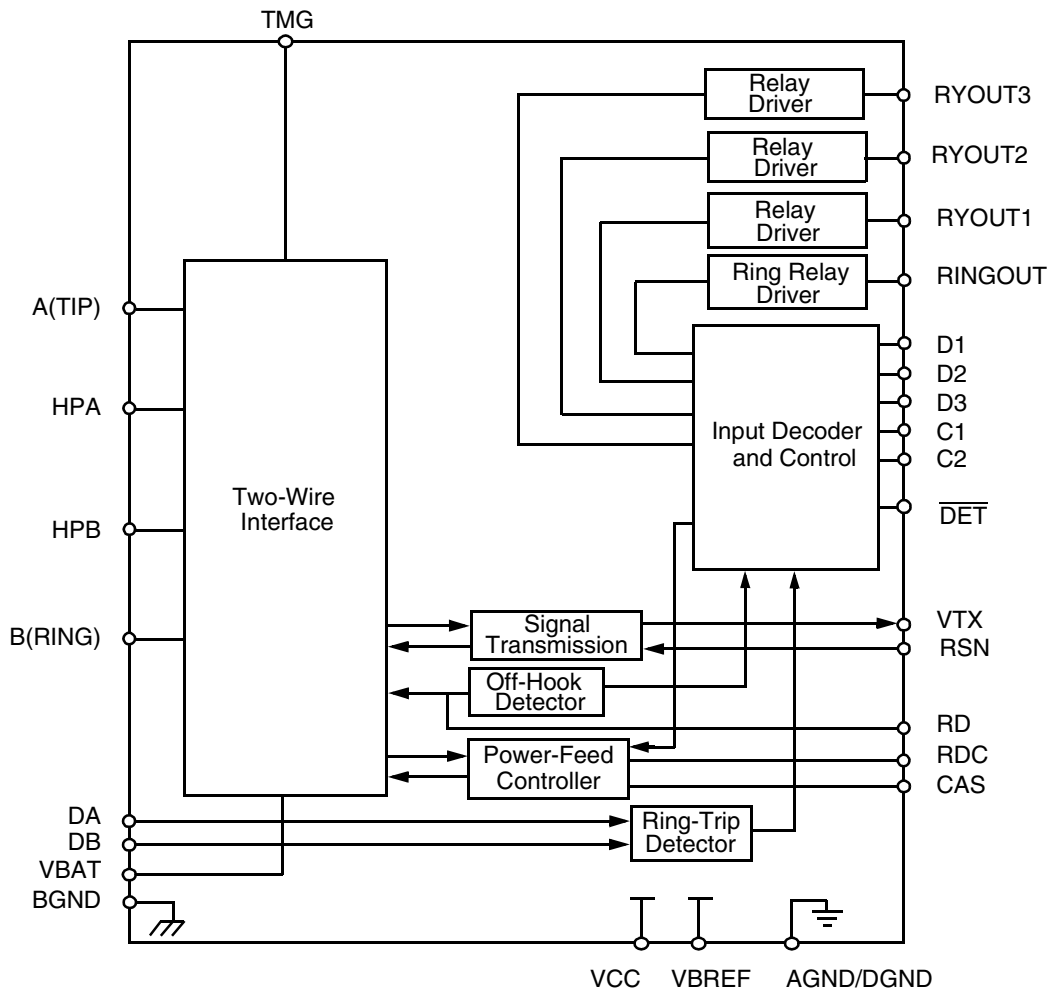

ORDERING INFORMATION

Standard Products

Legerity standard products are available in several packages and operating ranges. The order number (Valid Combination) is formed by a combination of the elements below.

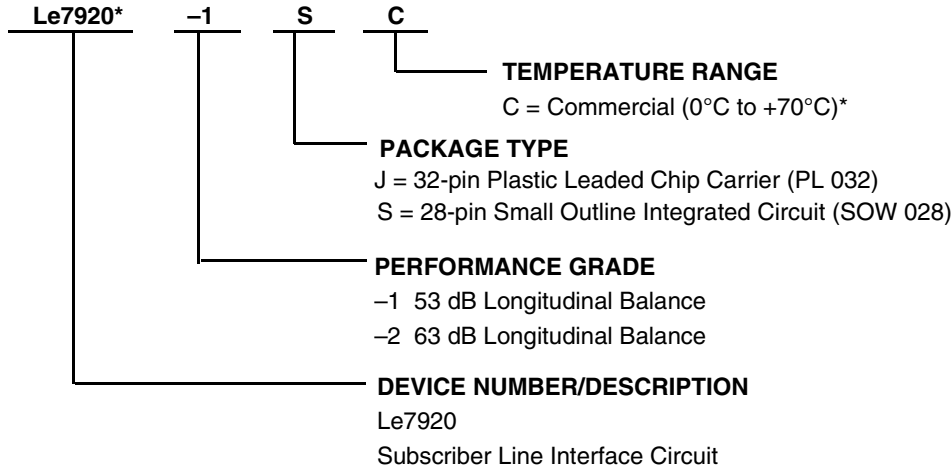

Valid Combinations		
Le7920*	-1	JC
	-2	SC

Valid Combinations

Valid Combinations list configurations planned to be supported in volume for this device. Consult the local Legerity sales office to confirm availability of specific valid combinations, to check on newly released combinations, and to obtain additional data on Legerity's standard military-grade products.

**Legerity reserves the right to fulfill all orders for this device with parts marked with the "Am" part number prefix, until such time as all inventory bearing this mark has been depleted. It should be noted that parts marked with either the "Am" or the "Le" part number prefix are equivalent devices in terms of form, fit, and function. The only difference between the two is in the part number prefix appearing on the topside mark.*

CONNECTION DIAGRAMS

Top View

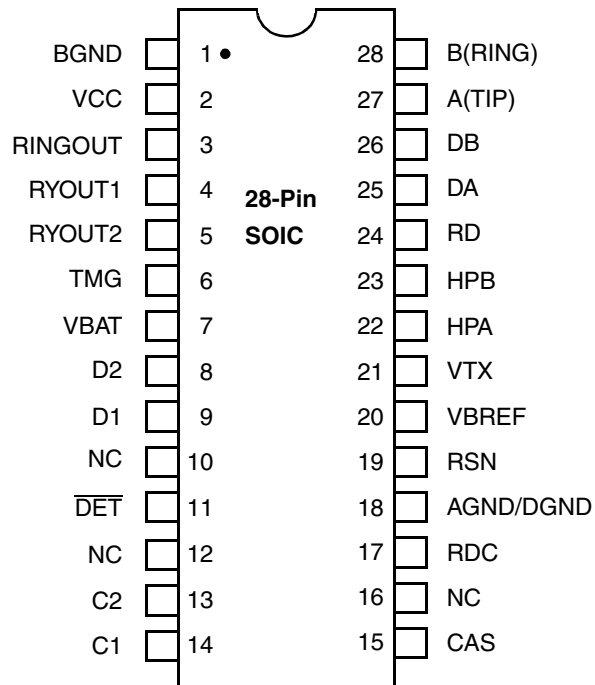
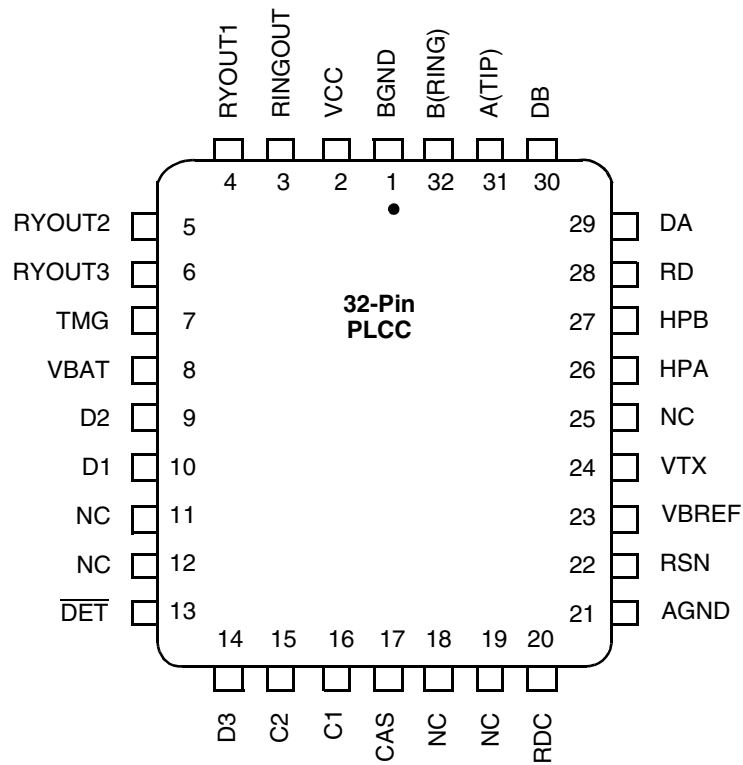

Notes:

1. Pin 1 is marked for orientation.
2. NC = No Connect

PIN DESCRIPTIONS

Pin Name	Type	Description
AGND/DGND	Ground	Analog and Digital ground.
A(TIP)	Output	Output of A(TIP) power amplifier.
BGND	Ground	Battery (power) ground.
B(RING)	Output	Output of B(RING) power amplifier.
C2–C1	Inputs	Decoder. TTL compatible. C2 is MSB and C1 is LSB.
CAS	Capacitor	Anti-Saturation pin for capacitor to filter reference voltage when operating in anti-saturation region.
D3–D1	Input	Relay Driver Control. D3–D1 control the relay drivers RYOUT1, RYOUT2, and RYOUT3. Logic Low on D1 activates the RYOUT1 relay driver. Logic Low on D2 activates the RYOUT2 relay driver. Logic Low on D3 activates the RYOUT3 relay driver. TTL compatible.
DA	Input	Ring-trip negative. Negative input to ring-trip comparator.
DB	Input	Ring-trip positive. Positive input to ring-trip comparator.
DET	Output	Switchhook detector. Logic Low indicates that selected detector is tripped. Logic inputs C2–C1, E1, and E0 select the detector. Open-collector with a built-in 15 k Ω pull-up resistor.
HPA	Capacitor	High-Pass Filter Capacitor. A(TIP) side of high-pass filter capacitor.
HPB	Capacitor	High-Pass Filter Capacitor. B(RING) side of high-pass filter capacitor.
NC	—	No Connect. Pin not internally connected.
RD	Resistor	Detect resistor. Detector threshold set and filter pin.
RDC	Resistor	DC feed resistor. Connection point for the DC feed current programming network. The other end of the network connects to the receiver summing node (RSN).
RINGOUT	Output	Ring Relay Driver. Open-collector driver with emitter internally connected to BGND.
RSN	Input	Receive Summing Node. The metallic current (both AC and DC) between A(TIP) and B(RING) is equal to 500 times the current into this pin. The networks that program receive gain, two-wire impedance, and feed resistance all connect to this node.
RYOUT1	Output	Relay/Switch Driver. Open-collector driver with emitter internally connected to BGND.
RYOUT2	Output	Relay/Switch Driver. Open-collector driver with emitter internally connected to BGND (PLCC only).
RYOUT3	Output	Relay/Switch Driver. Open-collector driver with emitter internally connected to BGND (PLCC only).
TMG	—	Thermal Management. External resistor connects between this pin and VBAT to offload power from SLIC.
VBAT	Battery	Battery supply and connection to substrate.
VBREF	—	This is an Legerity reserved pin and must always be connected to the VBAT pin.
VCC	Power	+5 V power supply.
VTX	Output	Transmit Audio. This output is a 0.50 gain version of the A(TIP) and B(RING) metallic voltage. VTX also sources the two-wire input impedance programming network.

ABSOLUTE MAXIMUM RATINGS

Storage temperature	-55°C to +150°C
V _{CC} with respect to AGND/DGND	-0.4 V to +7.0 V
V _{BAT} with respect to AGND/DGND:	
Continuous	+0.4 V to -70 V
10 ms	+0.4 V to -75 V
BGND with respect to AGND/DGND.....	+3 V to -3 V
A(TIP) or B(RING) to BGND:	
Continuous	V _{BAT} to +1 V
10 ms (f = 0.1 Hz)	-70 V to +5 V
1 μs (f = 0.1 Hz)	-80 V to +8 V
250 ns (f = 0.1 Hz)	-90 V to +12 V
Current from A(TIP) or B(RING).....	±150 mA
RINGOUT/RVOUT1,2,3 current.....	50 mA
RINGOUT/RVOUT1,2,3 voltage	BGND to +7 V
RINGOUT/RVOUT1,2,3 transient	BGND to +10 V
DA and DB inputs	
Voltage on ring-trip inputs	V _{BAT} to 0 V
Current into ring-trip inputs	±10 mA
C2-C1 and D3-D1	
Input voltage	-0.4 V to V _{CC} + 0.4 V
Maximum power dissipation, continuous, T _A = 70°C, No heat sink (See note)	
In 32-pin PLCC package.....	1.7 W
Thermal Data:	θ _{JA}
In 32-pin PLCC package.....	43°C/W typ
ESD immunity/pin (HBM)	1500 V

Note: Thermal limiting circuitry on chip will shut down the circuit at a junction temperature of about 165°C. Continuous operation above 145°C junction temperature may degrade device reliability.

Stresses above those listed under "Absolute Maximum Ratings" may cause permanent device failure. Functionality at or above these limits is not implied. Exposure to absolute maximum ratings for extended periods may affect device reliability.

OPERATING RANGES

Commercial (C) Devices

Ambient temperature	0°C to +70°C*
V _{CC}	4.75 V to 5.25 V
V _{BAT}	-19 V to -58 V
AGND/DGND	0 V
BGND with respect to AGND/DGND	-100 mV to +100 mV
Load resistance on VTX to ground	20 kΩ min

The operating ranges define those limits between which the functionality of the device is guaranteed.

* Legerity guarantees the performance of this device over commercial (0 to 70°C) and industrial (-40 to 85°C) temperature ranges by conducting electrical characterization over each range and by conducting a production test with single insertion coupled to periodic sampling. These characterization and test procedures comply with section 4.6.2 of Bellcore TR-TSY-000357 Component Reliability Assurance Requirements for Telecommunications Equipment.

ELECTRICAL CHARACTERISTICS

Description	Test Conditions (See Note 1)	Min	Typ	Max	Unit	Note
Transmission Performance						
2-wire return loss	200 Hz to 3.4 kHz	26			dB	1, 4
Analog output (VTX) impedance			3	20	Ω	4
Analog (VTX) output offset voltage		-50		+50	mV	
Overload level, 2-wire and 4-wire	Active state	2.5			Vpk	2a
Overload level	On hook, $R_{LAC} = 600 \Omega$	0.77			Vrms	2b
THD, Total Harmonic Distortion	0 dBm +7 dBm		-64 -55	-50 -40	dB	5
THD, On hook	0 dBm, $R_{LAC} = 600 \Omega$			-36		
Longitudinal Capability (See Test Circuit D)						
Longitudinal to metallic L-T, L-4 balance	200 Hz to 1 kHz 0°C to +70°C 0°C to +70°C -40°C to +85°C -40°C to +85°C	-1*	52		dB	4 4
		-2	63			
		-1	50			
		-2	58			
	1 kHz to 3.4 kHz 0°C to +70°C 0°C to +70°C -40°C to +85°C -40°C to +85°C	-1*	52			4 4
		-2	58			
		-1	50			
		-2	53			
Longitudinal signal generation 4-L	200 Hz to 3.4 kHz	40				
Longitudinal current per pin (A or B)	Active state	20	27	35	mArms	8
Longitudinal impedance at A or B	0 to 100 Hz		25		Ω /pin	
Idle Channel Noise						
C-message weighted noise	$R_L = 600 \Omega$ 0°C to +70°C		7	+10	dBmnc	4
	$R_L = 600 \Omega$ -40°C to +85°C			+12		
Psophometric weighted noise	$R_L = 600 \Omega$ 0°C to +70°C		-83	-80	dBmp	
	$R_L = 600 \Omega$ -40°C to +85°C			-78		
Insertion Loss and Balance Return Signal (See Test Circuits A and B)						
Gain accuracy 4- to 2-wire	0 dBm, 1 kHz	-0.20	0	+0.20	dB	4
Gain accuracy 2- to 4-wire, 4- to 4-wire	0 dBm, 1 kHz	-6.22	-6.02	-5.82		
Gain accuracy, 4- to 2-wire	On hook	-0.35		+0.35		
Gain accuracy, 2- to 4-wire, 4- to 4-wire	On hook	-6.37	-6.02	-5.67		
Gain accuracy over frequency	300 to 3.4 kHz relative to 1 kHz	-0.15		+0.15		
Gain tracking	+3 dBm to -55 dBm relative to 0 dBm	-0.15		+0.15		
Gain tracking On hook	0 dBm to -37 dBm +3 dBm to 0 dBm	-0.15 -0.35		+0.15 +0.35		
Group delay	0 dBm, 1 kHz		4		μ s	4, 7

Note:

* Performance Grade

ELECTRICAL CHARACTERISTICS (continued)

Description	Test Conditions (See Note 1)	Min	Typ	Max	Unit	Note
Line Characteristics						
I_L , Short Loops, Active state	$R_{LDC} = 600 \Omega$	20	23	26	mA	
I_L , Long Loops, Active state	$R_{LDC} = 1930 \Omega$, $BAT = -42.75 V$, $T_A = 25^\circ C$	18	19			
I_L , Accuracy, Standby state	$I_L = \frac{ BAT - 3 V}{R_L + 400}$ $T_A = 25^\circ C$	$0.7I_L$	I_L	$1.3I_L$		
	Constant-current region	18	30			
I_L , Loop current, Disconnect state	$R_L = 0$			100	μA	
I_L LIM	Active, A and B to ground		85	120	mA	
VAB, Open Circuit voltage	$V_{BAT} = -52 V$	-42.75	-44		V	
Power Supply Rejection Ratio ($V_{RIPPLE} = 100$ mVrms), Active Normal State						
V_{CC}	50 Hz to 3.4 kHz	30	40		dB	5
V_{BAT}	50 Hz to 3.4 kHz	28	50			
Effective internal resistance	CAS pin to V_{BAT}	85	170	255	k Ω	4
Power Dissipation						
On hook, Disconnect state			25	70	mW	
On hook, Standby state			35	100		
On hook, Active state			125	270		
Off hook, Standby state	$R_L = 600 \Omega$		860	1200		
Off hook, Active state	$R_L = 300 \Omega$, $R_{TMG} = 2350 \Omega$		450	800		
Supply Currents, Battery = -48V						
I_{CC} , On-hook V_{CC} supply current	Disconnect state		1.7	4.0	mA	
	Standby state		2.2	4.0		
	Active state, $BAT = -48 V$		6.3	8.5		
I_{BAT} , On-hook V_{BAT} supply current	Disconnect state		0.25	1.0	mA	
	Standby state		0.55	1.5		
	Active state, $BAT = -48 V$		2.8	4.8		
RFI Rejection						
RFI rejection	100 kHz to 30 MHz, (See Figure F)			1.0	mVrms	4
Receive Summing Node (RSN)						
RSN DC voltage	$I_{RSN} = 0$ mA		0		V	4
RSN impedance	200 Hz to 3.4 kHz		10	20	Ω	
Logic Inputs (C2-C1 and D3-D1)						
V_{IH} , Input High voltage		2.0			V	
V_{IL} , Input Low voltage				0.8		
I_{IH} , Input High current		-75		40	μA	
I_{IL} , Input Low current		-400				
Logic Output (\overline{DET})						
V_{OL} , Output Low voltage	$I_{OUT} = 0.3$ mA, 15 k Ω to V_{CC}			0.40	V	
V_{OH} , Output High voltage	$I_{OUT} = -0.1$ mA, 15 k Ω to V_{CC}	2.4				
Ring-Trip Detector Input (DA, DB)						
Bias current		-500	-50		nA	
Offset voltage	Source resistance = 2 M Ω	-50	0	+50	mV	6

ELECTRICAL CHARACTERISTICS (continued)

Description	Test Conditions (See Note 1)	Min	Typ	Max	Unit	Note
Loop Detector						
On threshold	$R_D = 35.4 \text{ k}\Omega$	11.5		17.3	mA	
Off threshold	$R_D = 35.4 \text{ k}\Omega$	9.4		14.1		
Hysteresis	$R_D = 35.4 \text{ k}\Omega$	0		4.4		
Relay Driver Output (RINGOUT, RYOUT1, RYOUT2, RYOUT3)						
On voltage	$I_{OL} = 40 \text{ mA}$		+0.3	+0.7	V	
Off leakage	$V_{OH} = +5 \text{ V}$			100	μA	
Zener breakover	$I_Z = 100 \text{ }\mu\text{A}$	6	7.2		V	
Zener On voltage	$I_Z = 30 \text{ mA}$		10			

RELAY DRIVER SCHEMATICS

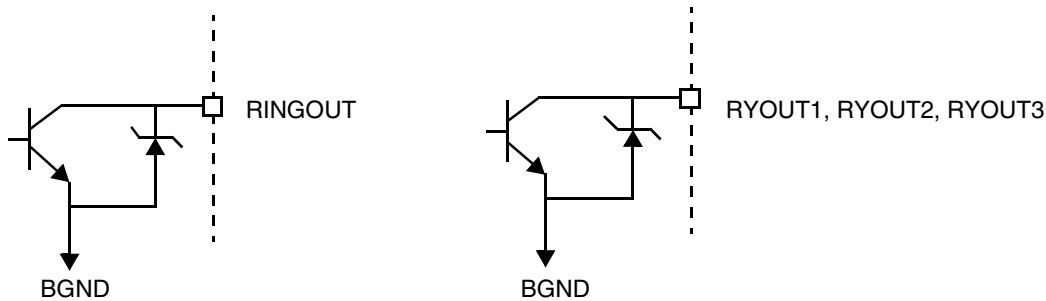

Notes:

- Unless otherwise noted, test conditions are $BAT = -52 \text{ V}$, $V_{CC} = +5 \text{ V}$, $R_L = 600 \text{ }\Omega$, $R_{DC1} = R_{DC2} = 27.17 \text{ k}\Omega$, $R_{TMG} = 2350 \text{ }\Omega$, $R_D = 35.4 \text{ k}\Omega$, no fuse resistors, $C_{HP} = 0.22 \text{ }\mu\text{F}$, $C_{DC} = 0.1 \text{ }\mu\text{F}$, $C_{CAS} = 0.33 \text{ }\mu\text{F}$, $D1 = 1N400x$, two-wire AC input impedance is a $600 \text{ }\Omega$ resistance synthesized by the programming network shown below.

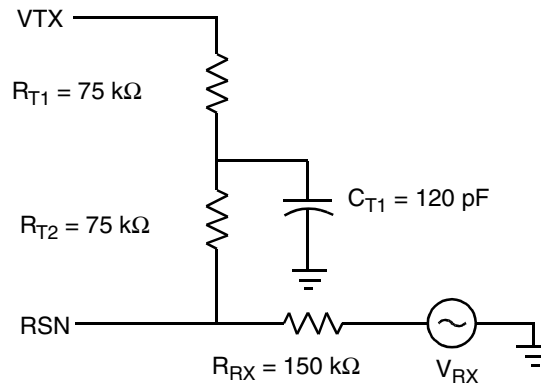

- Overload level is defined when $THD = 1\%$.
 - Overload level is defined when $THD = 1.5\%$.
- Balance return signal is the signal generated at V_{TX} by V_{RX} . This specification assumes that the two-wire, AC-load impedance matches the programmed impedance.
- Not tested in production. This parameter is guaranteed by characterization or correlation to other tests.
- This parameter is tested at 1 kHz in production. Performance at other frequencies is guaranteed by characterization.
- Tested with $0 \text{ }\Omega$ source impedance. $2 \text{ M}\Omega$ is specified for system design only.
- Group delay can be greatly reduced by using a Z_T network such as that shown in Note 1. The network reduces the group delay to less than $2 \text{ }\mu\text{s}$ and increases $2WRL$. The effect of group delay on linecard performance also may be compensated for by synthesizing complex impedance with the QSLAC™ or DSLAC™ device.
- Minimum current level guaranteed not to cause a false loop detect.

Table 1. SLIC Decoding

State	C2	C1	Two-Wire Status	$\overline{\text{DET}}$ Output
0	0	0	Disconnect	Ring trip
1	0	1	Ringing	Ring trip
2	1	0	Active	Loop detector
3	1	1	Standby	Loop detector

Table 2. User-Programmable Components

$Z_T = 250(Z_{2\text{WIN}} - 2R_F)$	Z_T is connected between the VTX and RSN pins. The fuse resistors are R_F , and $Z_{2\text{WIN}}$ is the desired 2-wire AC input impedance. When computing Z_T , the internal current amplifier pole and any external stray capacitance between VTX and RSN must be taken into account.
$Z_{\text{RX}} = \frac{Z_L}{G_{42\text{L}}} \cdot \frac{500Z_T}{Z_T + 250(Z_L + 2R_F)}$	Z_{RX} is connected from VRX to RSN. Z_T is defined above, and $G_{42\text{L}}$ is the desired receive gain.
$R_{\text{DC1}} + R_{\text{DC2}} = \frac{1250}{I_{\text{LOOP}}}$ $C_{\text{DC}} = 1.5 \text{ ms} \cdot \frac{R_{\text{DC1}} + R_{\text{DC2}}}{R_{\text{DC1}} \cdot R_{\text{DC2}}}$	R_{DC1} , R_{DC2} , and C_{DC} form the network connected to the R_{DC} pin. R_{DC1} and R_{DC2} are approximately equal. I_{LOOP} is the desired loop current in the constant-current region.
$R_{\text{DON}} = \frac{510}{I_T}$, $R_{\text{DOFF}} = \frac{415}{I_T}$, $C_D = \frac{0.5 \text{ ms}}{R_D}$	R_D and C_D form the network connected from R_D to AGND/DGND and I_T is the threshold current between on hook and off hook.
$C_{\text{CAS}} = \frac{1}{3.4 \cdot 10^5 \pi f_c}$	C_{CAS} is the regulator filter capacitor and f_c is the desired filter cut-off frequency.
$I_{\text{STANDBY}} = \frac{ V_{\text{BAT}} - 3 \text{ V}}{400 \Omega + R_L}$	Standby loop current (resistive region).
Thermal Management Equations (Normal Active and Tip Open States)	
$R_{\text{TMG}} \geq \left(\frac{ V_{\text{BAT}} - 6 \text{ V}}{I_{\text{LOOP}}} - 70 \Omega \right)$	R_{TMG} is connected from TMG to VBAT and saves power within the SLIC in Active and Disconnect state constant-currents only.
$P_{\text{RTMG}} = \frac{(V_{\text{BAT}} - 6 \text{ V} - (I_L \cdot R_L))^2}{(R_{\text{TMG}} + 70 \Omega)^2} \cdot R_{\text{TMG}}$	Power dissipated in the TMG resistor, R_{TMG} , during Active and Disconnect states.
$P_{\text{SLIC}} = V_{\text{BAT}} \cdot I_L - P_{\text{RTMG}} - R_L(I_L)^2 + 0.12 \text{ W}$	Power dissipated in the SLIC while in Active and Disconnect states.

DC FEED CHARACTERISTICS

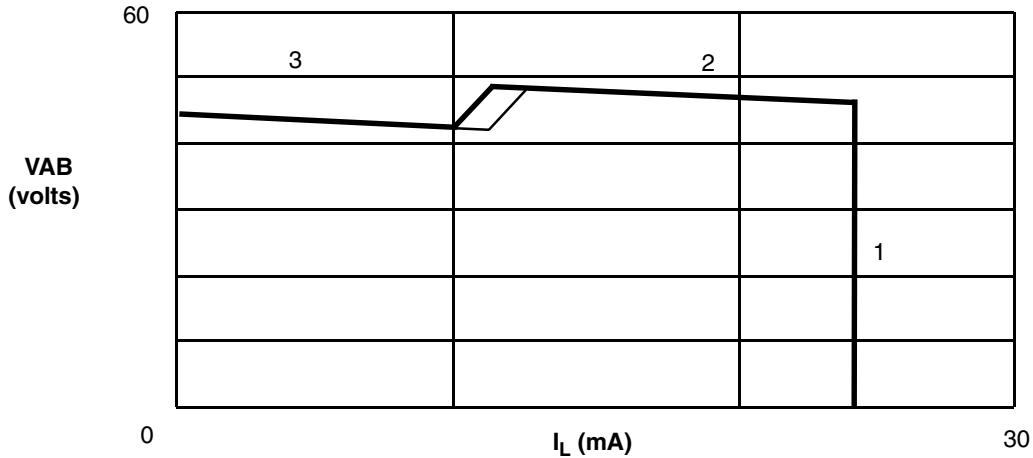

$$R_{DC} = R_{DC1} + R_{DC2} = 54.34 \text{ k}\Omega$$

$$BAT = -48 \text{ V}$$

Notes:

$$1. V_{AB} = I_L R_L' = \frac{1250}{R_{DC}} R_L', \text{ where } R_L' = R_L + 2R_F$$

$$2. V_{AB} = 0.857(|V_{BAT}| + 3.3) - I_L \frac{R_{DC}}{300}$$

$$3. V_{AB} = 0.857(|V_{BAT}| + 1.2) - I_L \frac{R_{DC}}{300}$$

a. Load Line (Typical)

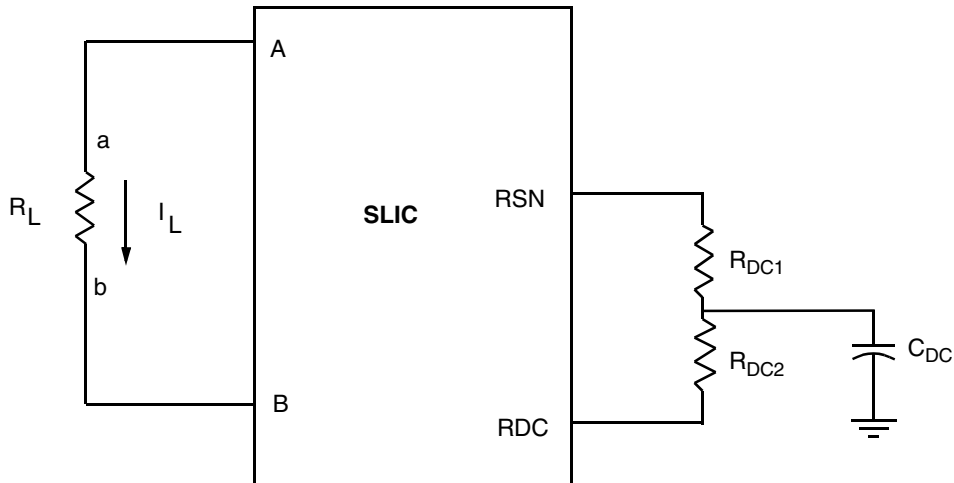

Feed current programmed by R_{DC1} and R_{DC2}

b. Feed Programming

Figure 1. DC Feed Characteristics

TEST CIRCUITS

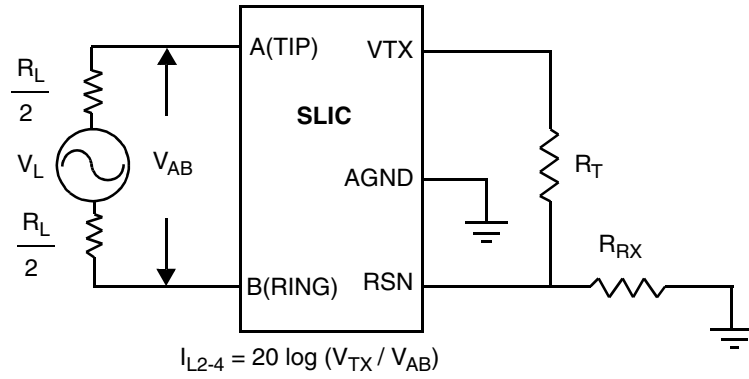

A. Two- to Four-Wire Insertion Loss

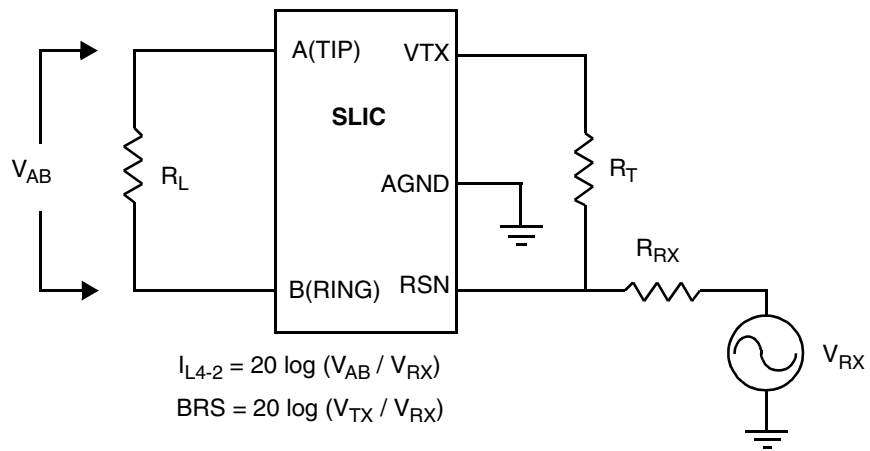

B. Four- to Two-Wire Insertion Loss and Balance Return Signal

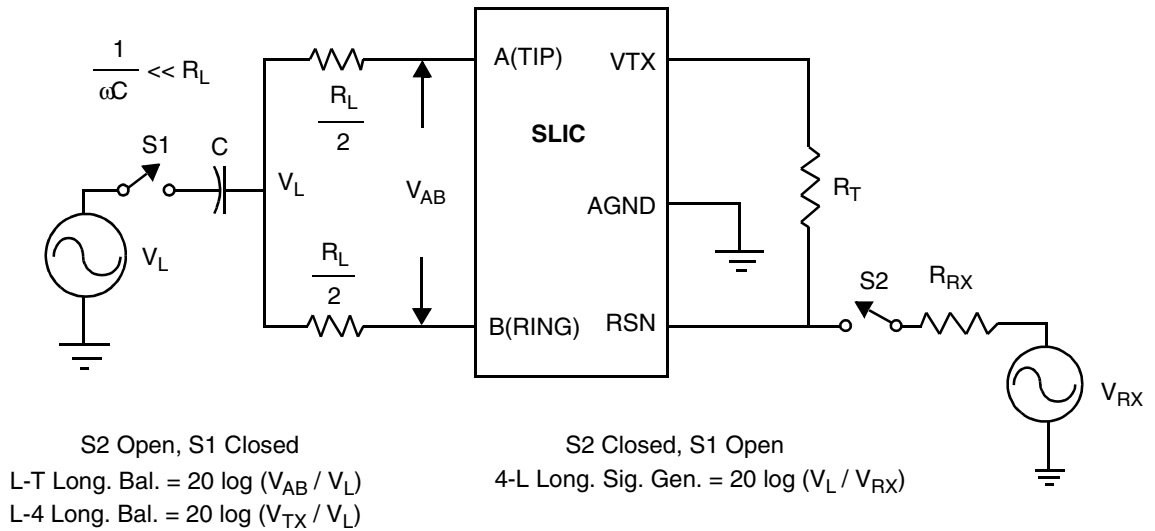

C. Longitudinal Balance

TEST CIRCUITS (continued)

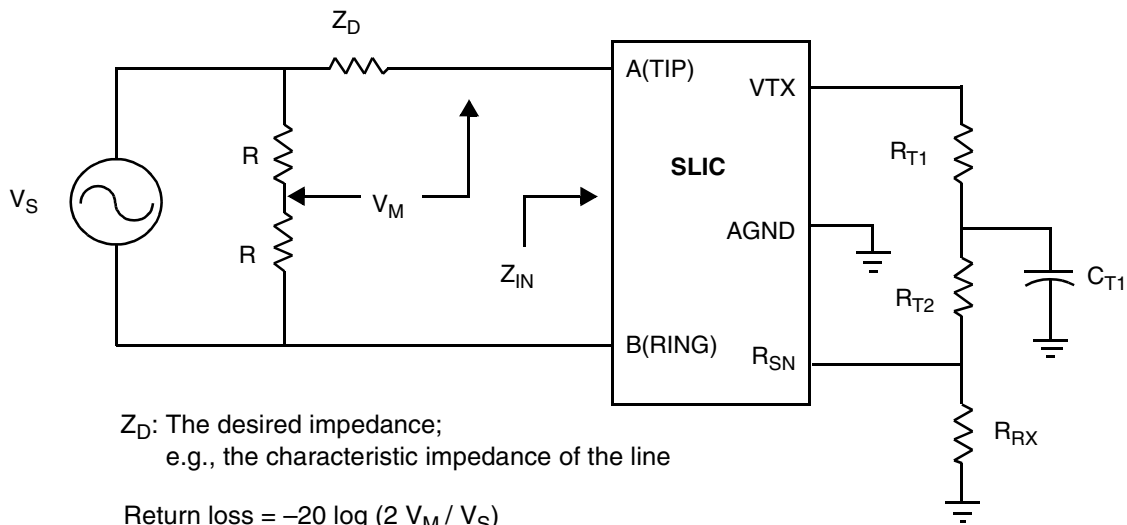

D. Two-Wire Return Loss Test Circuit

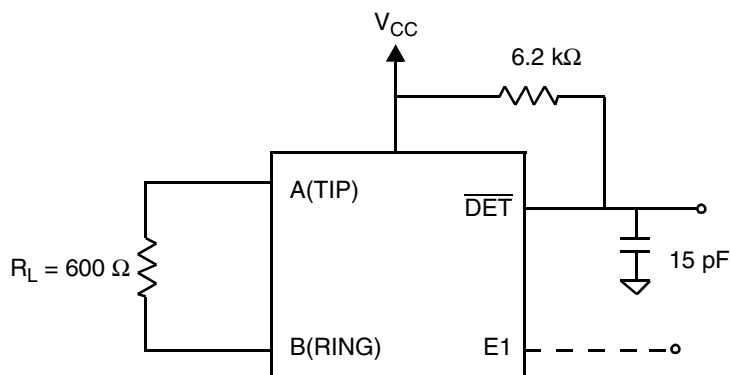

E. Loop-Detector Switching

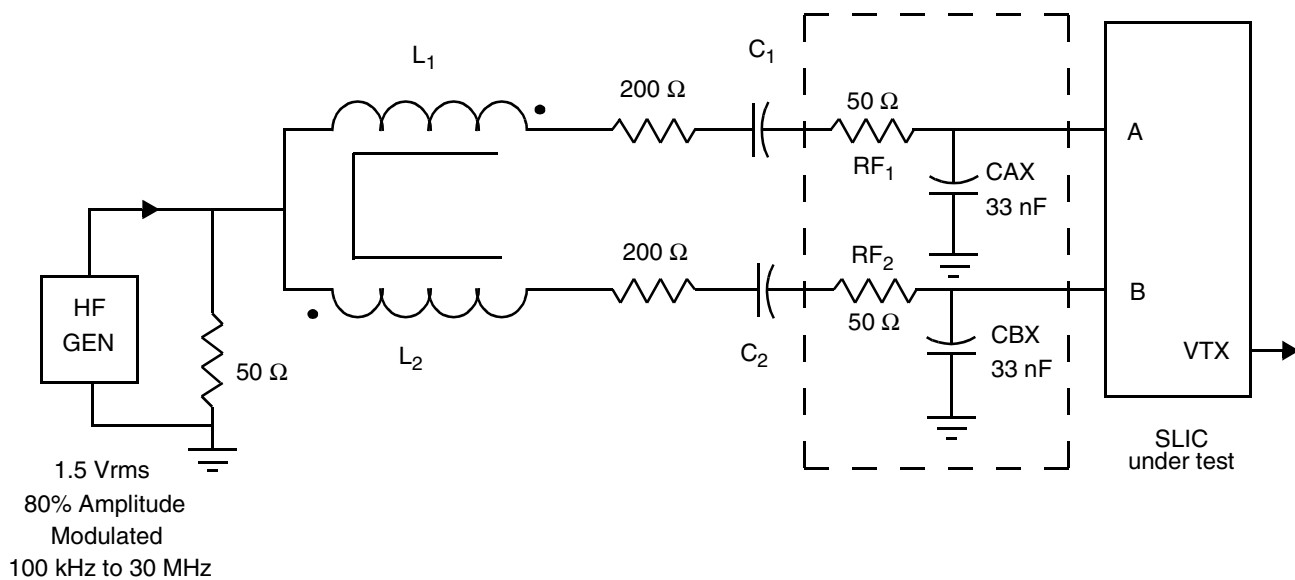

F. RFI Test Circuit

TEST CIRCUITS (continued)

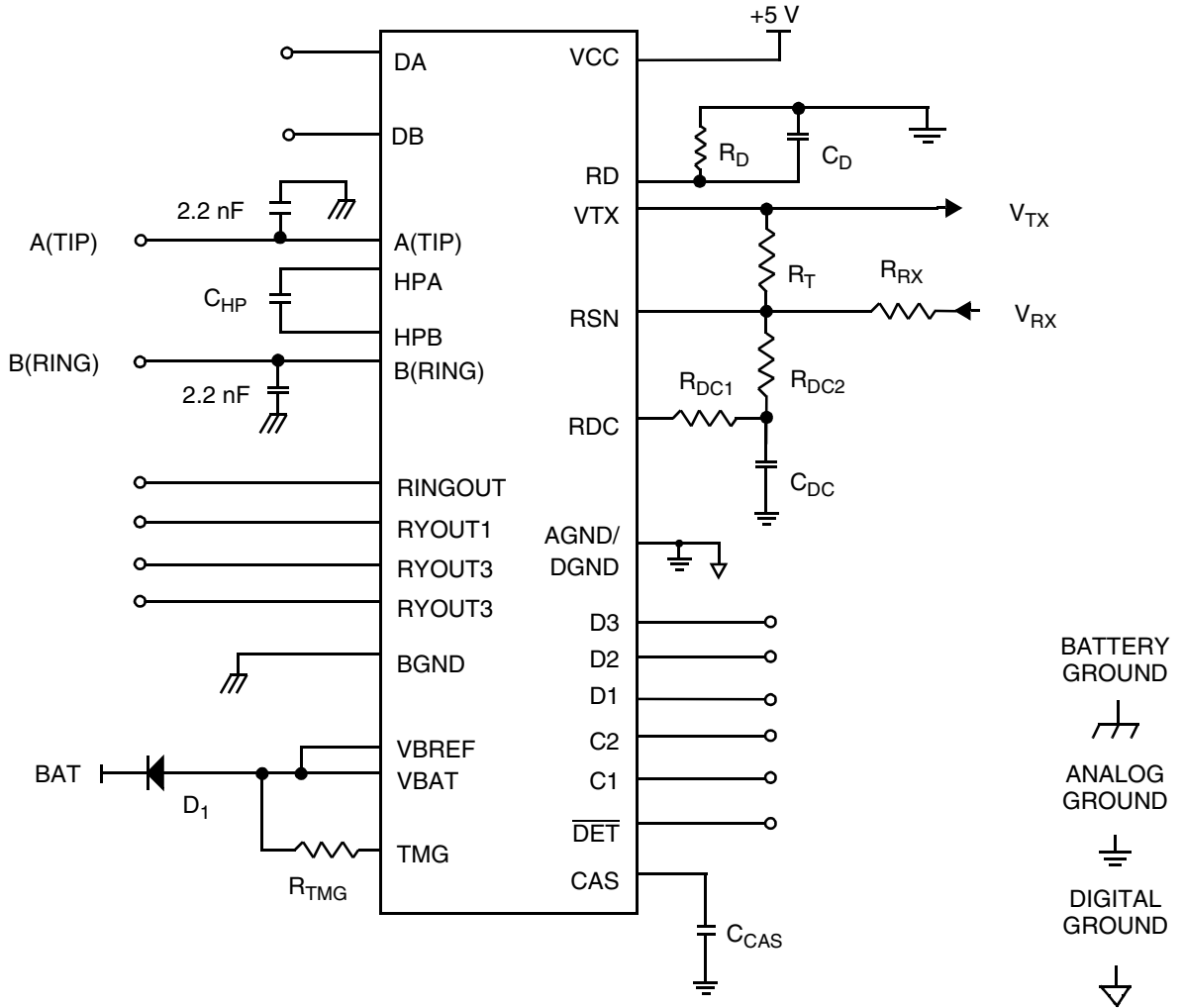

G. Le7920 Test Circuit

PHYSICAL DIMENSIONS

32-Pin PLCC

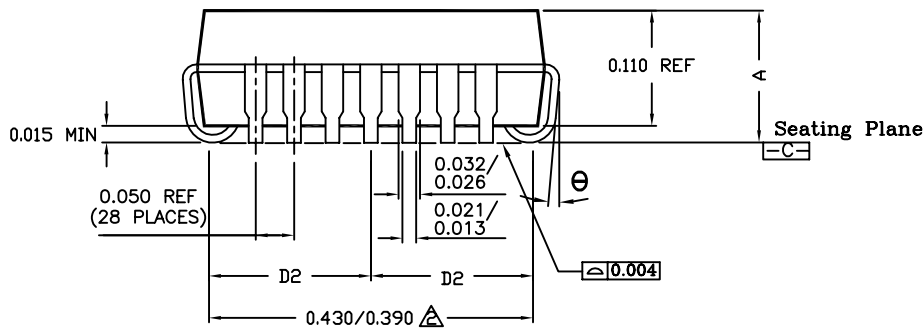
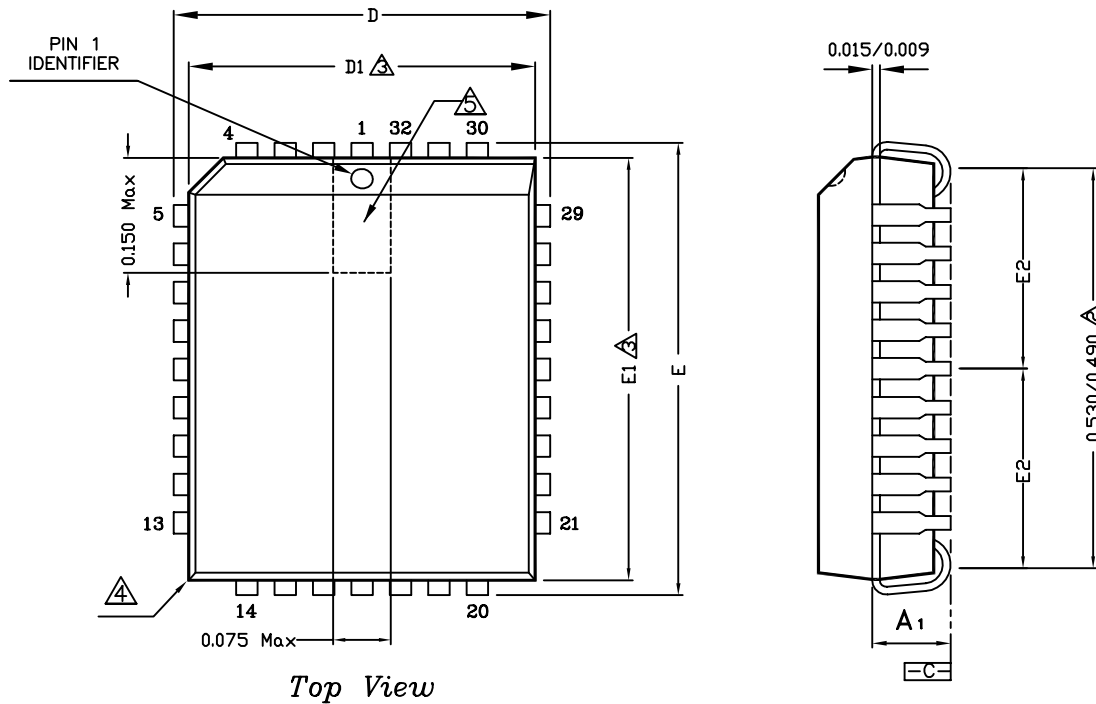

NOTE :

1. DIMENSIONING AND TOLERANCING CONFORM TO ASME Y14.5M-1994.
- △ TO BE MEASURED AT SEATING PLANE $\square C \square$ CONTACT POINT.
- △ DIMENSIONS D1 AND E1 DO NOT INCLUDE MOLD PROTUSION. ALLOWABLE MOLD PROTUSION IS 0.010 IN PER SIDE. DIMENSIONS D, AND E, INCLUDE MOLD MISMATCH AND DETERMINED AT THE PARTING LINE; THAT IS D1 AND E1 ARE MEASURED AT THE EXTREME MATERIAL CONDITION AT THE UPPER OR LOWER PARTING LINE.
- △ EXACT SHAPE OF THIS FEATURE IS OPTIONAL.
- △ DETAILS OF PIN 1 IDENTIFIER ARE OPTIONAL BUT MUST BE LOCATED WITHIN THE ZONE INDICATED.
6. SUM OF DAM BAR PROTUSIONS TO BE 0.007 MAX PER LEAD.
7. CONTROLLING DIMENSION : INCH.
8. REFERENCE DOCUMENT : JEDEC MS-016

Symbol	Dimension in inch		
	Min	Nom	Max
A	0.125	—	0.140
A1	0.075	0.090	0.095
D	0.485	0.490	0.495
D1	0.447	0.450	0.453
D2	0.205 REF		
E	0.585	0.590	0.595
E1	0.547	0.550	0.553
E2	0.255 REF		
θ	0°	—	10°

28-Pin SOIC

28-Pin SOIC

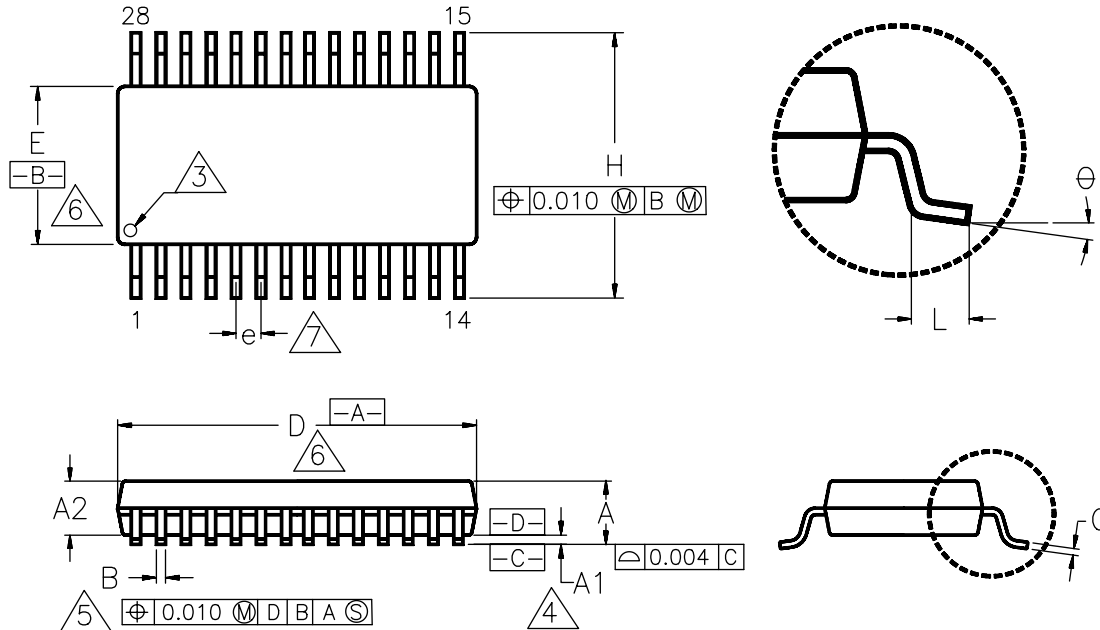

Dwg rev AC; 11/99

PACKAGE	SOW 028		
JEDEC	MO-059 (B) AC		
SYMBOL	MIN.	NOM.	MAX.
A	.080	.095	.100
A1	.002	.007	.014
A2	.086	.088	.090
B	.014	.016	.020
C	.006	.008	.0125
D	.697	.714	.728
E	.324	.346	.350
e	.050 BSC		
H	.453	.470	.500
L	.016	.031	.050
θ	0°	4°	8°

NOTES:

- ALL DIMENSIONS ARE IN INCHES.
- DIMENSIONING AND TOLERANCING PER ANSI Y14.5M – 1982.
- I.D. MARK SHALL BE LOCATED ADJACENT TO PIN 1.
- DIMENSION A1 IS MEASURED FROM THE BASE PLANE OF CONTACT THAT IS MADE WHEN THE PACKAGE IS ALLOWED TO REST FREELY ON A FLAT HORIZONTAL SURFACE. (SEATING PLANE).
- DIMENSION "B" DOES NOT INCLUDE DAMBAR PROTRUSION. ALLOWABLE DAMBAR PROTRUSION SHALL NOT EXCEED 0.006 INCHES PER SIDE.
- DIMENSIONS "D" AND "E" ARE REFERENCE DATUMS AND DO NOT INCLUDE MOLD FLASH OR PROTRUSIONS, BUT DO INCLUDE MOLD MISMATCH AS MEASURED AT THE MOLD PARTING LINE. MOLD FLASH OR PROTRUSIONS SHALL NOT EXCEED 0.006 INCHES PER SIDE.
- DIMENSION "e" IS MEASURED AT THE CENTERLINE OF THE LEADS.
- LEAD COPLANARITY SHALL BE WITHIN 0.004 INCHES AS MEASURED FROM THE SEATING PLANE.

REVISION SUMMARY

Revision C to Revision D

- Minor changes were made to the datasheet style and format to conform to Legerity standards.

Revision D to Revision E

- Absolute Maximum Ratings: Added ESD immunity specification.

Revision E to Revision F

- Added the 28-pin SOIC connection diagram and the SC option to the ordering information.

Revision F to Revision G

- The physical dimension (PL032) was added to the Physical Dimension section.

Revision G to Revision H

- Deleted the plastic DIP package and references to it.
- Updated the Pin Description table to correct inconsistencies.

Revision H to Revision I

- Updated device name from "Am7920" to "Le7920" throughout document.
- Absolute Maximum Ratings: Notes updated to standard.
- Operating Ranges: Temperature statement updated to standard.
- Updated "Sales Office Listing."
- Updated physical dimension drawings.

The contents of this document are provided in connection with Legerity, Inc. products. Legerity makes no representations or warranties with respect to the accuracy or completeness of the contents of this publication and reserves the right to make changes to specifications and product descriptions at any time without notice. No license, whether express, implied, arising by estoppel or otherwise, to any intellectual property rights is granted by this publication. Except as set forth in Legerity's Standard Terms and Conditions of Sale, Legerity assumes no liability whatsoever, and disclaims any express or implied warranty, relating to its products including, but not limited to, the implied warranty of merchantability, fitness for a particular purpose, or infringement of any intellectual property right.

Legerity's products are not designed, intended, authorized or warranted for use as components in systems intended for surgical implant into the body, or in other applications intended to support or sustain life, or in any other application in which the failure of Legerity's product could create a situation where personal injury, death, or severe property or environmental damage may occur. Legerity reserves the right to discontinue or make changes to its products at any time without notice.

© 2002 Legerity, Inc.
All rights reserved.

Trademarks

Legerity, the Legerity logo and combinations thereof, are trademarks of Legerity, Inc.

Other product names used in this publication are for identification purposes only and may be trademarks of their respective companies.



P.O. Box 18200
Austin, Texas 78760-8200

Telephone: (512) 228-5400
Fax: (512) 228-5508
North America Toll Free: (800) 432-4009

*To contact the Legerity Sales Office
nearest you, or to download or order
product literature, visit our website at
www.legerity.com.*

*To order literature in North America,
call:
(800) 572-4859
or email:
americallit@legerity.com*

*To order literature in Europe or Asia,
call:
44-0-1179-341607
or email:
Europe — eurolit@legerity.com
Asia — asialit@legerity.com*