



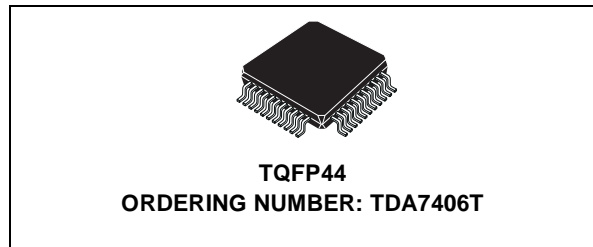
CAR RADIO SIGNAL PROCESSOR

Audio processor:

- 4 STEREO INPUTS
- 4 MONO INPUTS
- VOLUME CONTROL
- 7 BAND EQUALIZER FILTER CONTROL
- HIGH PASS FILTER FOR SUBWOOFER APPLICATION
- DIRECT MUTE AND SOFT MUTE
- INTERNAL BEEP GENERATION
- 4 INDEPENDENT SPEAKER OUTPUTS
- SOFT STEP SPEAKER CONTROL
- SUBWOOFER OUTPUT
- 7 BAND SPECTRUM ANALYZER
- FULL MIXING CAPABILITY
- PAUSE DETECTOR

Stereo decoder:

- RDS MUTE
- NO EXTERNAL ADJUSTMENTS
- AM/FM NOISEBLANKER WITH SEVERAL TRIGGER CONTROLS
- PROGRAMMABLE MULTIPATH DETECTOR



- QUALITY DETECTOR OUTPUT

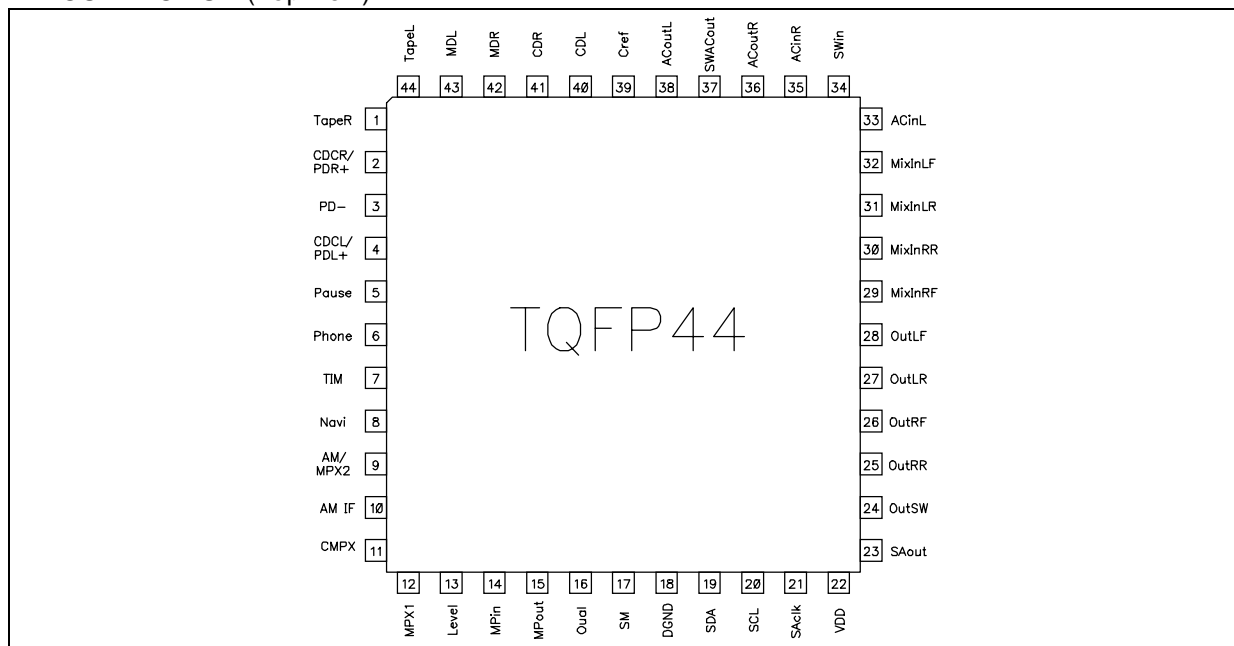
Digital control:

- I²C-BUS INTERFACE

DESCRIPTION

The device includes a high performance audio processor with 7 bands equalizer and spectrum analyzer plus a stereo decoder-noiseblanker. The whole low frequency signal processing necessary for state-of-the-art as well as future car radios is therefore provided. The digital control allows a full programming not only of the audioprocessor and filter characteristics but also in the stereodecoder part especially for the adaptation to different IF-devices.

PIN CONNECTION (Top view)



TDA7406T

SUPPLY

Symbol	Parameter	Test Conditions	Min.	Typ.	Max.	Unit
V _S	Supply Voltage		7.5	9	10	V
I _S	Supply Current	V _S = 9V	42	60	78	mA
SVRR	Ripple Rejection @ 1kHz	Audioprocessor (all Filters flat)		60		dB
		Stereodecoder + Audioprocessor		55		dB

THERMAL DATA

Symbol	Description	Value	Unit
R _{th j-pins}	Thermal Resistance Junction-pins max	65	°C/W

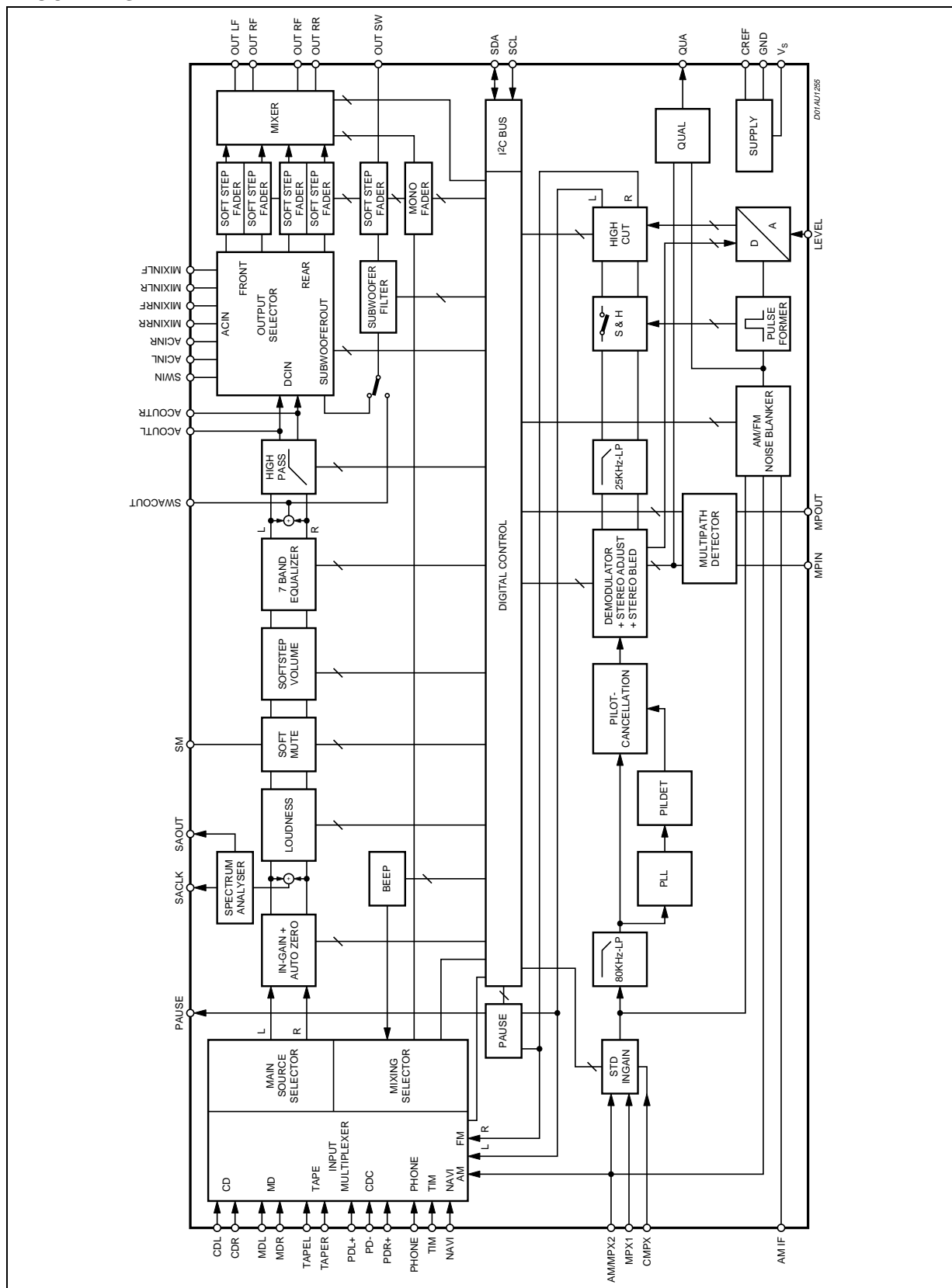
ABSOLUTE MAXIMUM RATINGS

Symbol	Parameter	Value	Unit
V _S	Operating Supply Voltage	10.5	1 V
T _{amb}	Operating Temperature Range	-40 to 85	°C
T _{stg}	Storage Temperature Range	-55 to +150	°C

ESD:

All pins are protected against ESD according to the MIL883 standard.

BLOCK DIAGRAM



1 AUDIOPROCESSOR PART**Features:**

- Input multiplexer
 - Pseudo differential CDC stereo input, programmable as single-ended input.
 - 3 single-ended stereo inputs.
 - 4 single-ended mono inputs.
 - Input gain adjust 0...15dB in 1dB steps.
 - Internal offset-cancellation (autozero).
- Beep
 - Internal beep generator with 4 different frequencies.
- Mixing stage
 - Beep, Phone- and Navi-Input mixable to all speaker outputs.
 - TIM or tuner (FM/AM) programmable as fourth mixing source.
 - Level control range of 95dB (+15...-79db).
- Loudness
 - Loudness programmable center frequency and filter slope.
 - 0...19dB attenuation in 1dB steps.
 - selectable flat-mode (constant attenuation).
- Volume
 - Gain/Attenuation with 0.5dB step resolution.
 - soft-step control with programmable blend times.
 - 110dB range (+32...-79db).
- Equalizer
 - Seven bands equalizer with 2nd order frequency response switch-capacitors filters.
 - Center frequency programmable for lowest and highest filter.
 - Programmable quality factor in four steps for each filter.
 - ±15dB range with 1dB steps.
- Spectrum analyzer
 - seven bandpass 2nd order frequency response switch-capacitors filters
 - Programmable quality factor for different visual appearance
 - Analog output
 - Controlled by external serial clock
- High pass Filter
 - 2nd order Butterworth high pass with programmable cut-off frequency
 - Selectable flat-mode
- Speakers
 - 4 independent speaker controls with separate mute.
 - Control range 95dB (+15...-79dB) in 1dB steps with soft step.
 - 4 independent programmable mix inputs with 50% mixing ratio
- Subwoofer
 - Single-ended monaural output
 - control range 95dB (+15...-79dB) in 1dB steps with soft step.
 - separate mute
- Mute functions
 - direct mute
 - digitally controlled Soft mute with 4 programmable mute-time

Table 1. ELECTRICAL CHARACTERISTICS(V_S=9V; T_{amb}=25°C; R_L=10kΩ; all gains=0dB; f=1kHz; unless otherwise specified)

Symbol	Parameter	Test Condition	Min.	Typ.	Max.	Unit
INPUT SELECTOR						
R _{in}	Input Resistance	all single ended Inputs	70	100	130	kΩ
V _{CL}	Clipping Level		2.2	2.6		V _{RMS}
S _{IN}	Input Separation		80	100		dB
G _{IN MIN}	Min. Input Gain		-1	0	1	dB
G _{IN MAX}	Max. Input Gain		13	15	17	dB
G _{STEP}	Step Resolution		0.5	1	1.5	dB
V _{DC}	DC Steps	Adjacent Gain Steps	-5	1	5	mV
		G _{MIN} to G _{MAX}	-10	61	10	mV
V _{offset}	Remaining offset with Autozero			0.5		mV
DIFFERENTIAL STEREO INPUTS						
R _{in}	Input Resistance (see Fig. 1)	Differential	70	100	130	kΩ
CMRR	Common Mode Rejection Ratio	V _{CM} = 1V _{RMS} @ 1kHz	46	70		dB
		V _{CM} = 1V _{RMS} @ 10kHz	46	60		dB
e _{NO}	Output-Noise @ Speaker-Outputs	20Hz - 20kHz, flat; all stages 0dB		11		μV
BEEP CONTROL						
V _{RMS}	Beep Level	Mix-Gain = 6dB	250	350	500	mV
f _{Beep}	Beep Frequency	f _{Beep1}	475	500	525	Hz
		f _{Beep2}	740	780	820	Hz
		f _{Beep3}	1.48	1.56	1.64	kHz
		f _{Beep4}	2.28	2.4	2.52	kHz
MIXING CONTROL						
M _{LEVEL}	Mixing Ratio	Main / Mix-Source		-6/-6		dB
G _{MAX}	Max. Gain		13	15	17	dB
A _{MAX}	Max. Attenuation		-83	-79	-75	dB
A _{STEP}	Attenuation Step		0.5	1	1.5	dB
LOUDNESS CONTROL						
A _{STEP}	Step Resolution		0.5	1	1.5	dB
A _{MAX}	Max. Attenuation		-21	-19	-17	dB
f _{Peak}	Peak Frequency	f _{P1}	180	200	220	Hz
		f _{P2}	360	400	440	Hz
		f _{P3}	540	600	660	Hz
		f _{P4}	720	800	880	Hz
VOLUME CONTROL						
G _{MAX}	Max. Gain		30	32	34	dB

TDA7406T

Table 1. ELECTRICAL CHARACTERISTICS (continued)

($V_S=9V$; $T_{amb}=25^\circ C$; $R_L=10k\Omega$; all gains=0dB; $f=1kHz$; unless otherwise specified)

Symbol	Parameter	Test Condition	Min.	Typ.	Max.	Unit
A _{MAX}	Max. Attenuation		-83	-79	-75	dB
A _{STEP}	Step Resolution		0	0.5	1	dB
E _A	Attenuation Set Error	G = -20 to +20dB	-0.75	0	+0.75	dB
		G = -80 to -20dB	-4	0	3	dB
E _T	Tracking Error				2	dB
V _{DC}	DC Steps	Adjacent Attenuation Steps		0.1	3	mV
		From 0dB to G _{MIN}		0.5	5	mV

SOFT MUTE

A _{MUTE}	Mute Attenuation		80	100		dB
T _D	Delay Time	T1		0.48	1	ms
		T2		0.96	2	ms
		T3	70	123	170	ms
		T4	200	324	600	ms
V _{TH low}	Low Threshold for SM-Pin ¹⁾				1	V
V _{TH high}	High Threshold for SM - Pin		2.5			V
R _{PU}	Internal pull-up resistor		32	45	58	k Ω
V _{PU}	Internal pull-up Voltage			3.3		V

EQUALIZER CONTROL

C _{RANGE}	Control Range		± 14	± 15	± 16	dB
A _{STEP}	Step Resolution		0.5	1	1.5	dB
f _{C1}	Center Frequency Band 1	f _{C1a}	55	62	69	Hz
		f _{C1b}	90	100	110	Hz
f _{C2}	Center Frequency Band 2	f _{C2}	141	157	173	Hz
f _{C3}	Center Frequency Band 3	f _{C3}	365	396	437	Hz
f _{C4}	Center Frequency Band 4	f _{C4}	0.9	1	1.1	kHz
f _{C5}	Center Frequency Band 5	f _{C5}	2.25	2.51	2.766	kHz
f _{C6}	Center Frequency Band 6	f _{C6a}	3.6	4	4.4	kHz
		f _{C6b}	5.70	6.34	6.98	kHz
f _{C7}	Center Frequency Band 7	f _{C7a}	13.5	15	16.5	kHz
		f _{C7b}	14.4	16	17.6	kHz
Q	Quality Factor	Q ₁	0.9	1	1.1	
		Q ₂	1.26	1.4	1.54	
		Q ₃	1.62	1.8	1.98	
		Q ₄	1.98	2.2	2.44	

1) The SM-Pin is active low (Mute = 0)

Table 1. ELECTRICAL CHARACTERISTICS (continued)(V_S=9V; T_{amb}=25°C; R_L=10kΩ; all gains=0dB; f=1kHz; unless otherwise specified)

Symbol	Parameter	Test Condition	Min.	Typ.	Max.	Unit
DC _{GAIN}	DC-gain, Band 1	DC = off	-1	0	+1	dB
		DC = on, 15dB boost		4		dB

SPECTRUM ANALYZER CONTROL

V _{SAOut}	Output Voltage Range		0		3.3	V
f _{C1}	Center Frequency Band 1	f _{C1}	55	62	69	Hz
f _{C2}	Center Frequency Band 2	f _{C2}	141	157	173	Hz
f _{C3}	Center Frequency Band 3	f _{C3}	356	396	436	Hz
f _{C4}	Center Frequency Band 4	f _{C4}	0.9	1	1.1	kHz
f _{C5}	Center Frequency Band 5	f _{C5}	2.26	2.51	2.76	kHz
f _{C6}	Center Frequency Band 6	f _{C6}	5.70	6.34	6.98	kHz
f _{C7}	Center Frequency Band 7	f _{C7}	14.4	16	17.6	kHz
Q	Quality Factor	Q ₁	1.62	1.8	1.98	
		Q ₂	3.15	3.5	3.85	
f _{SAClk}	Clock Frequency		1		100	kHz
t _{SAdel}	Analog Output Delay Time		2			μs
t _{repeat}	Spectrum Analyzer Repeat Time		50			ms
t _{intres}	Internal Reset Time			3		ms

PAUSE DETECTOR

V _{TH}	Zero Crossing Threshold	Window 1		40		mV
		Window 2		80		mV
		Window 3		160		mV
I _{DELAY}	Pull-Up Current		15	25	35	μA
V _{THP}	Pause Threshold			3		V

SPEAKER ATTENUATORS

R _{in}	Input Impedance		35	50	65	kΩ
G _{MAX}	Max. Gain		14.5	15.5	16.5	dB
A _{MAX}	Max. Attenuation		-83.5	-79.5	-75	dB
A _{STEP}	Step Resolution		0.5	1	1.5	dB
A _{MUTE}	Output Mute Attenuation		80	90		dB
E _E	Attenuation Set Error				3	dB
V _{DC}	DC Steps	Adjacent Attenuation Steps		0.5	5	mV
M _R	Mixing Ratio	Signal/Mix _{In}		50/50		%

AUDIO OUTPUTS

V _{CLIP}	Clipping Level	Thd=0.3%	2.2	2.6		V _{RMS}
R _L	Output Load Resistance		2			kΩ

TDA7406T

Table 1. ELECTRICAL CHARACTERISTICS (continued)

($V_S=9V$; $T_{amb}=25^\circ C$; $R_L=10k\Omega$; all gains=0dB; $f=1kHz$; unless otherwise specified)

Symbol	Parameter	Test Condition	Min.	Typ.	Max.	Unit
C_L	Output Load Capacitance				10	nF
R_{OUT}	Output Impedance			30	120	Ω
V_{DC}	DC Voltage Level		4.3	4.5	4.7	V

HIGH PASS

f_{HP}	Highpass corner frequency	f_{HP1}	81	90	99	Hz
		f_{HP2}	122	135	148	Hz
		f_{HP3}	162	180	198	Hz
		f_{HP4}	194	215	236	Hz

SUBWOOFER ATTENUATOR

R_{in}	Input Impedance		35	50	65	k Ω
G_{MAX}	Max. Gain		14	15	16	dB
A_{ATTN}	Max. Attenuation		-83	-79	-75	dB
A_{STEP}	Step Resolution		0	1	1.5	dB
A_{MUTE}	Output Mute Attenuation		80	90		dB
E_E	Attenuation Set Error				2	dB
V_{DC}	DC Steps	Adjacent Attenuation Steps		1	5	mV

SUBWOOFER Lowpass

f_{LP}	Lowpass corner frequency	f_{LP1}	72	80	88	Hz
		f_{LP2}	108	120	132	Hz
		f_{LP3}	144	160	176	Hz

GENERAL

e_{NO}	Output Noise	BW = 20Hz - 20kHz output muted		3	15	μV
		BW = 20Hz - 20kHz all gains = 0dB single ended inputs		10	20	μV μV
S/N	Signal to Noise Ratio	all gains = 0dB flat; $V_O = 2V_{RMS}$		103		dB
		All EQ-bands at +12dB; Q = 1.0 a-weighted; $V_O = 2.6V_{RMS}$		87		dB
d	distortion	$V_{IN} = 1V_{RMS}$; all stages 0dB		0.01	0.1	%
		$V_{OUT} = 1V_{RMS}$; Bass & Treble = 12dB		0.05	0.1	%
S_C	Channel Separation left/right		80	90		dB

2 DESCRIPTION OF THE AUDIOPROCESSOR PART

2.1 Input stages

In the basic configuration there is a source-selector with 8 inputs: one pseudo-differential (CDC), three single ended stereo (MD, CD, Tape), three single-ended mono (PHONE, NAVI, TIM) plus the “tuner” input. The tuner input takes the signal from either MPX1 or MPX2/AM pins (through the stereodecoder) see Fig. 1.

2.1.1 Pseudo-differential stereo Input (PD)

The PD input is implemented as a buffered pseudo-differential stereo stage with $100\text{k}\Omega$ input-impedance at each input pin. This input is also configurable as single-ended stereo input (CDC, see pin-out). The common input-pin, PD- features a fast charge switch to speed up the charge time of external capacitors. This switch is released the first time the input-selector data-byte (0) is assessed.

2.1.2 Single-ended stereo Inputs, single-ended mono inputs and FM-MPX input

All single ended inputs have an input impedance of $100\text{k}\Omega$. The AM-pin can be connected to the input of the stereo-decoder in order to use the AM-noiseblanker and AM-High-Cut feature. As input “Tuner” for the input selector either the stereo-decoder output or the AM-pin is selectable.

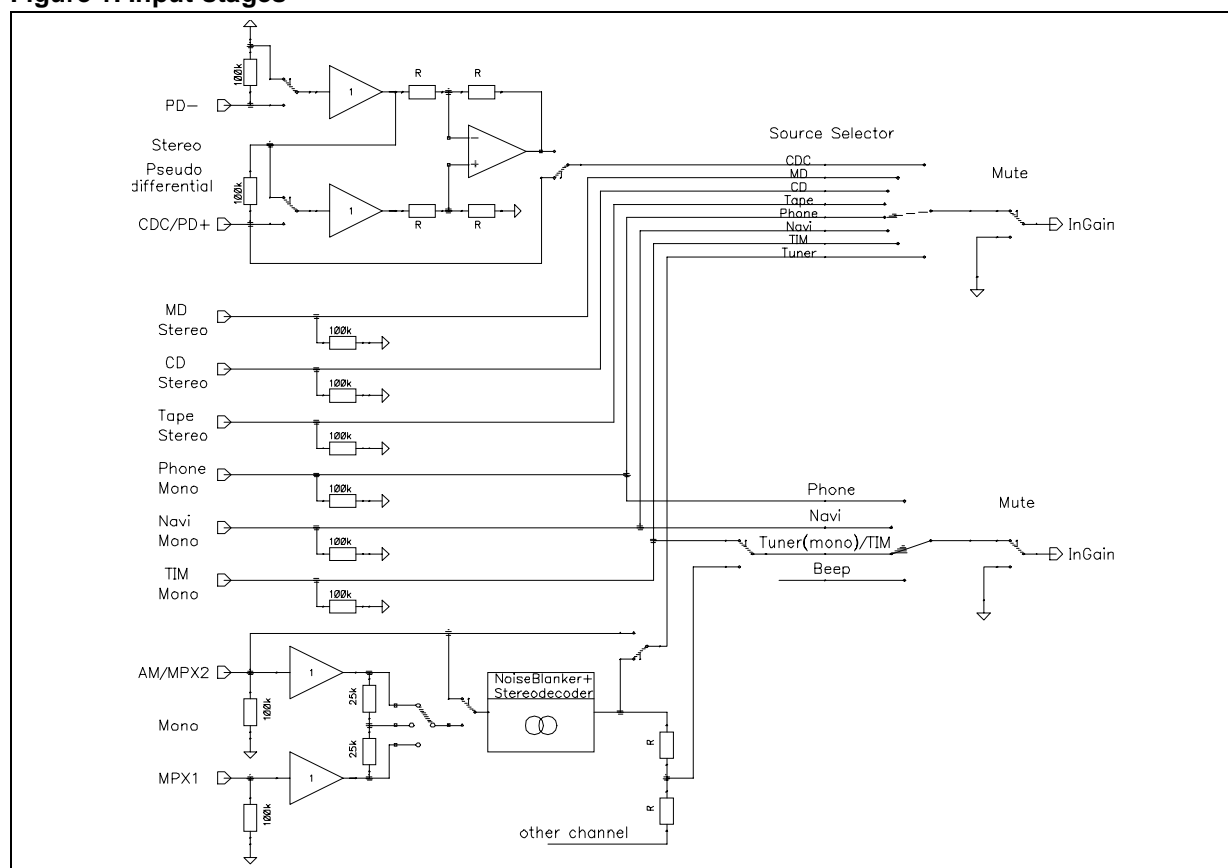
2.1.3 Mixing Selector

It is possible to enable/disable the mixing feature (ratio 50%) at the outputs stages between whichever input source and one of the following signals: Beep, Phone, Navigator and Tuner/TIM.

2.1.4 Beep Generator

There are four possible selectable beeping frequencies: 600Hz, 780Hz, 1.56KHz and 2.4KHz.

Figure 1. Input-stages



2.2 AutoZero

The AutoZero allows a reduction of the number of pins as well as external components by canceling any offset generated by or before the In-Gain-stage (Please notice that externally generated offsets, e.g. generated through the leakage current of the coupling capacitors, are not canceled).

The auto-zeroing is started every time the DATA-BYTE 0 is selected and needs max. **0.3ms** for the alignment. To avoid audible clicks the Audioprocessor have to be muted by soft mute or hard mute during this time.

2.2.1 AutoZero for Stereodecoder-Selection

A special procedure is recommended for selecting the stereodecoder at the input-selector to guarantee an optimum offset-cancellation:

(Step 0: SoftMute or Mute the signal-path)

Step 1: Temporary deselect the stereodecoder at the input-selector

Step 2: Configure the stereodecoder via IIC-Bus

Step 3: Wait 1ms

Step 4: Select the stereodecoder

The root cause of this procedure is, that after muting the stereodecoder (Step 1), the internal stereodecoder filters have to settle in order to perform a proper offset-cancellation.

2.2.2 AutoZero-Remain

In some cases, for example if the μ P is executing a refresh cycle of the IIC-Bus-programming, it is not useful to start a new AutoZero-action because no new source is selected and an undesired mute would appear at the outputs. For such applications the TDA7406T could be switched in the **AutoZero-Remain-Mode** (Bit 6 of the subaddress-byte). If this bit is set to high, the DATABYTE 0 could be loaded without invoking the AutoZero and the old adjustment-value remains.

2.2.3 PAUSE Detector

A pause detector stage with programmable threshold (40/80/160mV) is provided (see data Byte 14).

The pause detector info is available at the PAUSE pin; a capacitor must be connected between this pin and GND.

When the incoming signal is detected to be outside the selected window, the external capacitor is discharged. When the signal is inside the window, the capacitor is integrating up.

The pause status can be detected in two ways:

- a) reading directly the PAUSE pin level
 - Pause Off = level low (<3.0V)
 - Pause On = level high (>3.0V)
- b) by reading the I2C transmitted byte, bit P
 - P = 1 pause active
 - P = 0 no pause detected

The external capacitor value fixes the time constant. The pull up current is 25 μ A typical.

2.3 Loudness

There are four parameters programmable in the loudness stage:

- **Attenuation:** 0 to -19dB attenuation in 1dB steps vs. frequency (see the response at $f_p = 400\text{Hz}$ in Figure 2).
- **Peak Frequency:** Four programmable peak frequencies: 200,400,600 and 800Hz (see Figure 3).
- **Filter Order:** First or second order frequency response (see Figure 4).
- **Flat mode:** Selectable flat-mode. In flat mode the loudness stage works as a 0dB to -19dB attenuator.

Figure 2. Loudness Attenuation @ $f_p = 400\text{Hz}$.

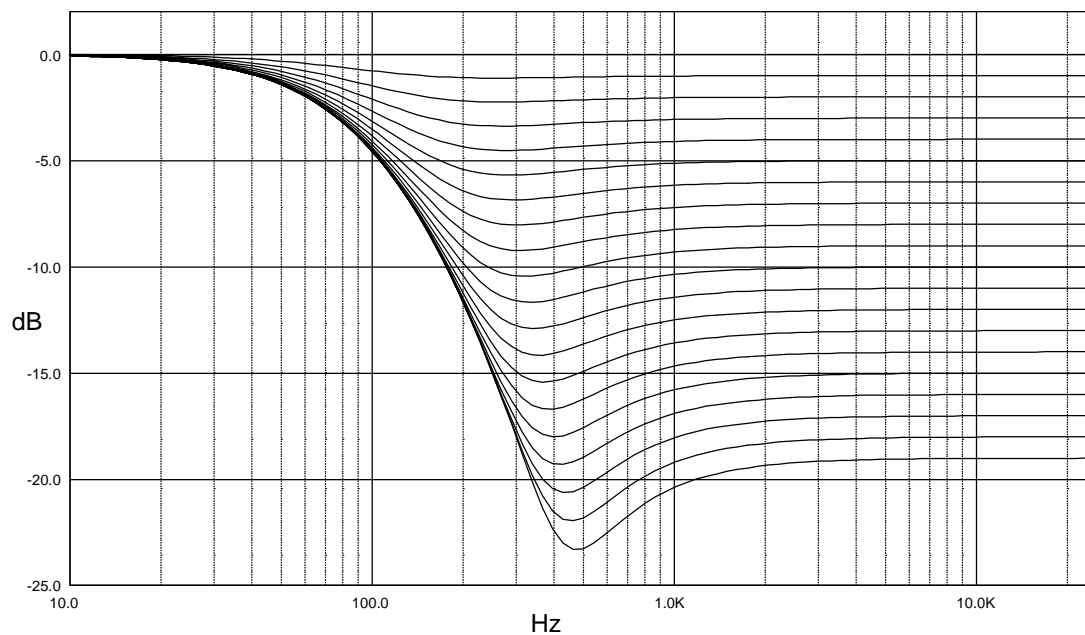


Figure 3. Loudness Center frequencies @ Attn. = 15dB

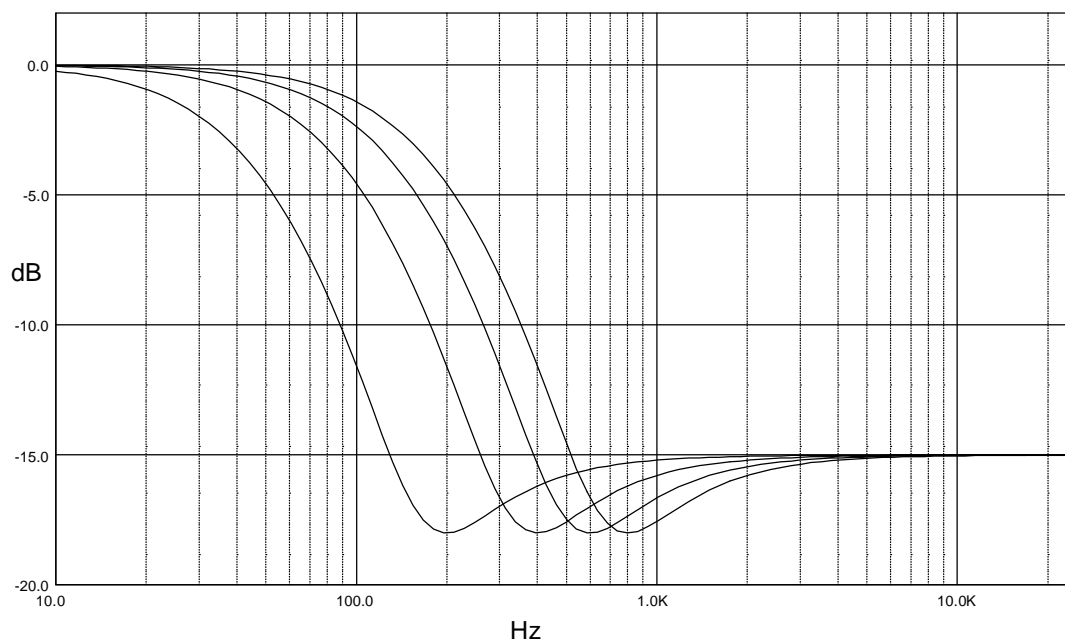
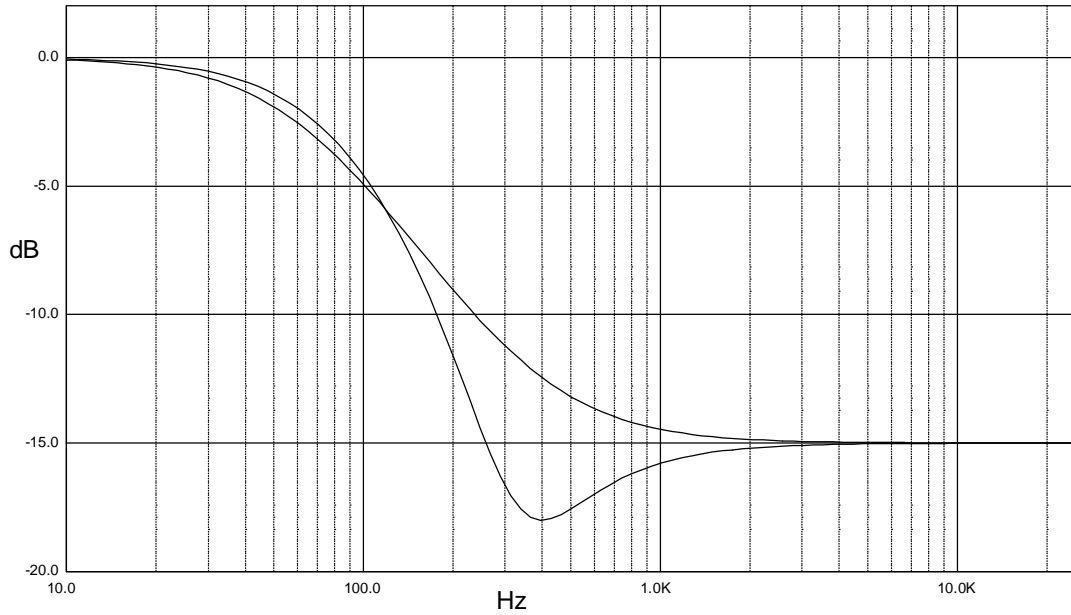


Figure 4. 1st and 2nd Order Loudness @ Attn. = 15dB, fP=400Hz

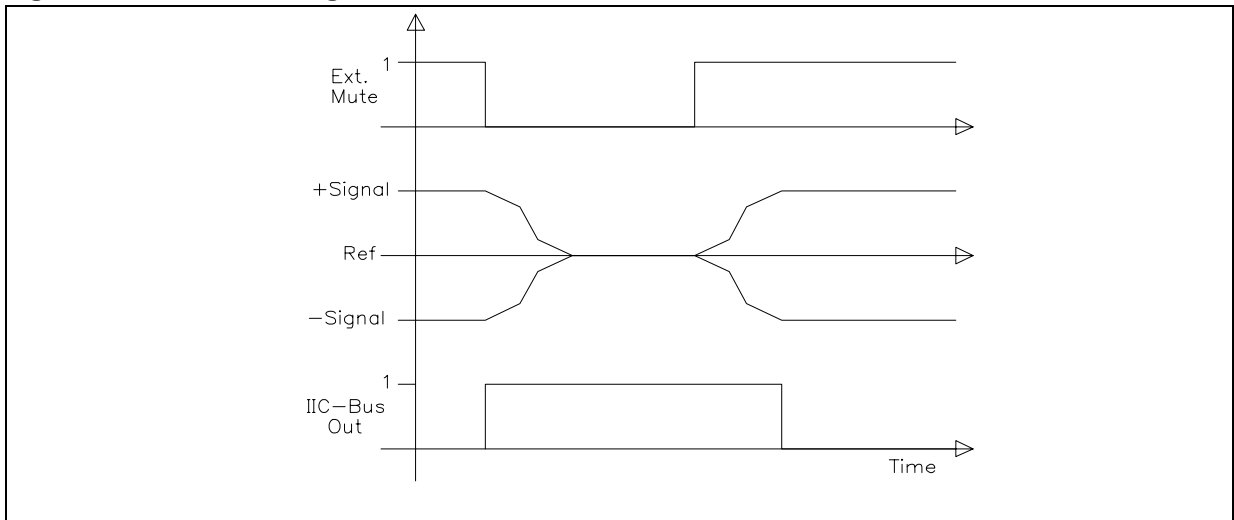


2.4 Soft Mute

The digitally controlled Soft Mute stage allows signal muting/demuting with a programmable slope. The Mute time is selectable among 4 values: 0.48, 0.96, 123 and 324ms. The mute process can either be activated by the Soft Mute pin or via the I²C-bus. This slope is realized in a special S-shaped curve to mute slow in the critical regions (see Figure 5).

For timing purposes the I²C-bus output register (Bit0 = SM read bit) is set to 1 from the start of muting until the end of de-muting.

Figure 5. Soft Mute-Timing



Note: Please notice that a started Mute-action is always terminated and could not be interrupted by a change of the mute -signal.

2.5 Volume Control

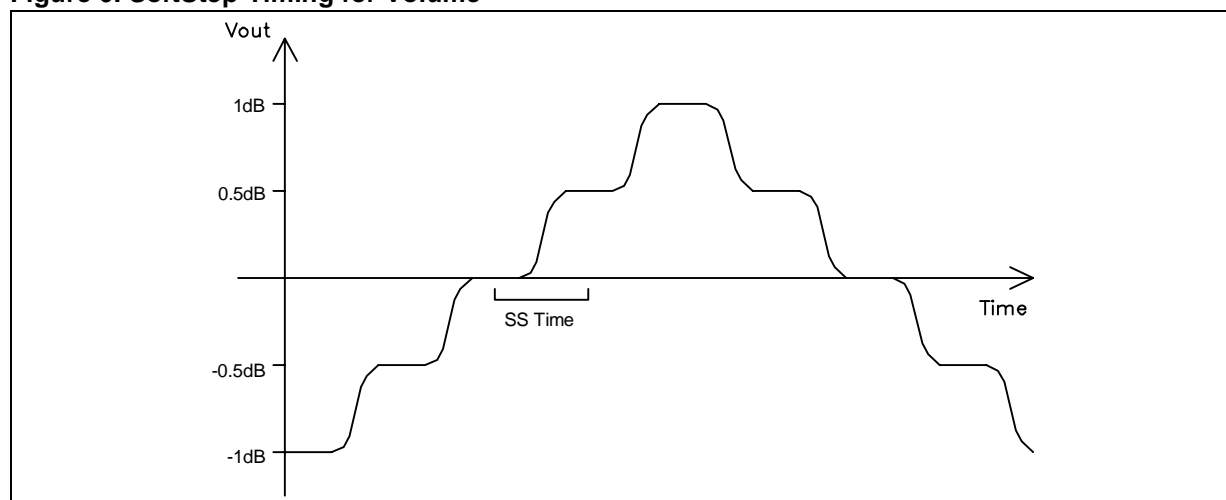
2.5.1 Gain/Attenuation Control

The volume control can range from a gain of 32dB up to an attenuation of 79dB; however it is not recommended to use a gain higher than 20dB for performance reasons.

2.5.2 Soft Step Volume

When the speaker-level is changed, audible clicks could appear at the output. The root cause of those clicks could either be a DC offset before the speaker-stage or the sudden change of the envelope of the audio signal. With the SoftStep-feature both kinds of clicks could be reduced to a minimum and are no more audible. The blend-time from one step to the next is programmable with four different values: 320 μ s, 1.28ms, 5.12ms and 20.4ms.

Figure 6. SoftStep-Timing for Volume



Note: For steps more than 0.5dB (Volume) or 1dB (Speaker) the SoftStep mode should be deactivated because it could generate a hard 1dB step during blending.

2.6 The Seven Band Equalizer

2.6.1 Equalizer Filter

Each filter is realized as a switched capacitor with a 2nd order frequency response.

There are three parameters programmable in the equalizer filter:

- **Attenuation:** ± 15 dB in 1db step resolution (Figure 7 shows the boost and cut response as a function of frequency at a center frequency of 1kHz.)
- **Center Frequency:** This parameter is programmable in the filter stages 1(62/100Hz), 6(4/6.34kHz) and 7(15/16kHz). The others bands are fixed at: 157, 396, 1K and 2.5K Hertz (see Figure 8).
- **Quality Factors:** The four possible quality factors are 1, 1.4, 1.8 and 2.2 (see Figure 9).

The center frequency, Q, DC-mode and boost/cut can be set fully independently for each filter. Figure 10 shows the superposition of all equalizer filter curves for different quality factors.

Figure 7. Equalizer filter control @ $f_{Center} = 1\text{kHz}$, $Q = 1.0$

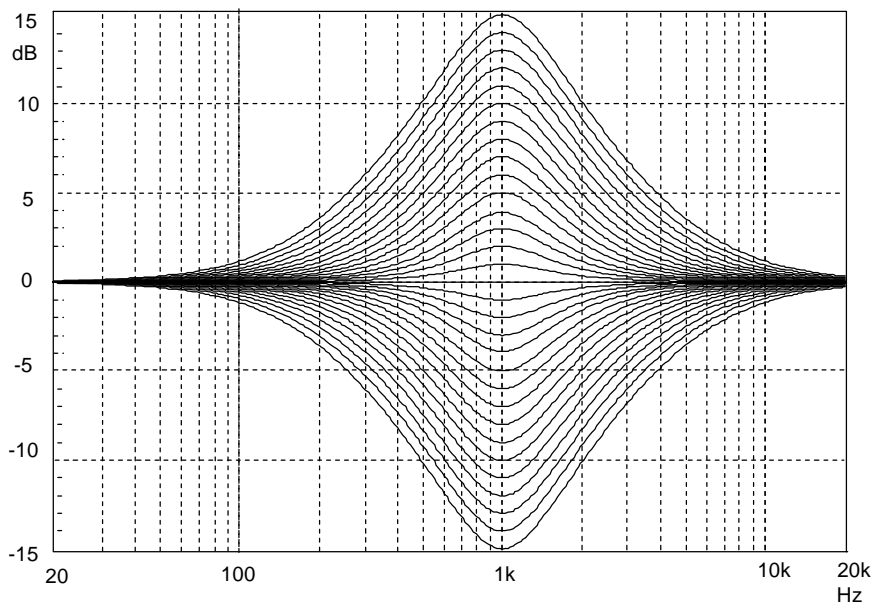


Figure 8. Center frequencies @ Gain = 15dB, $Q = 1.0$

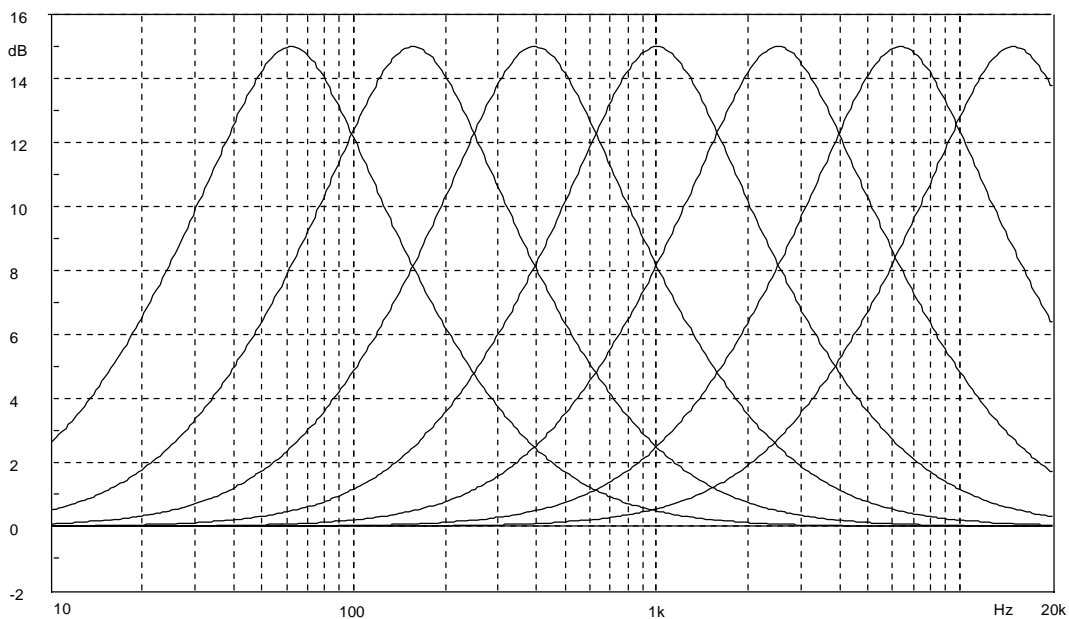
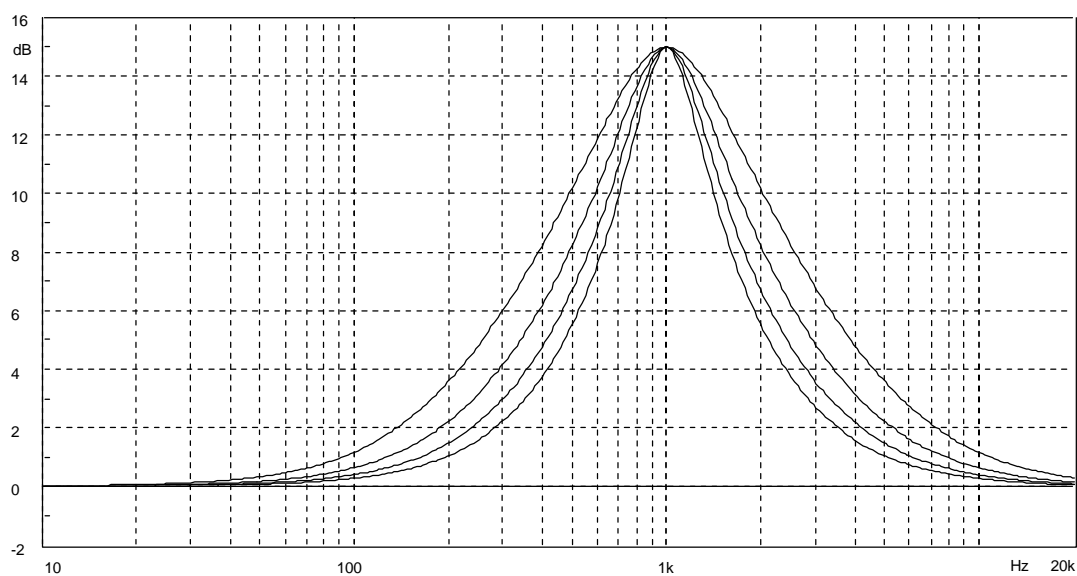
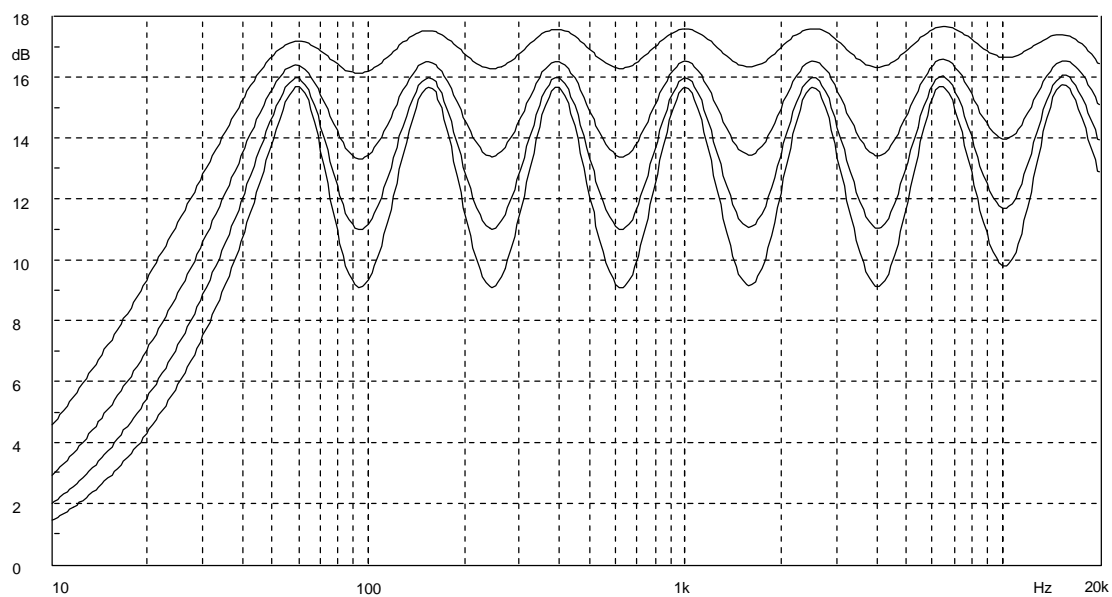
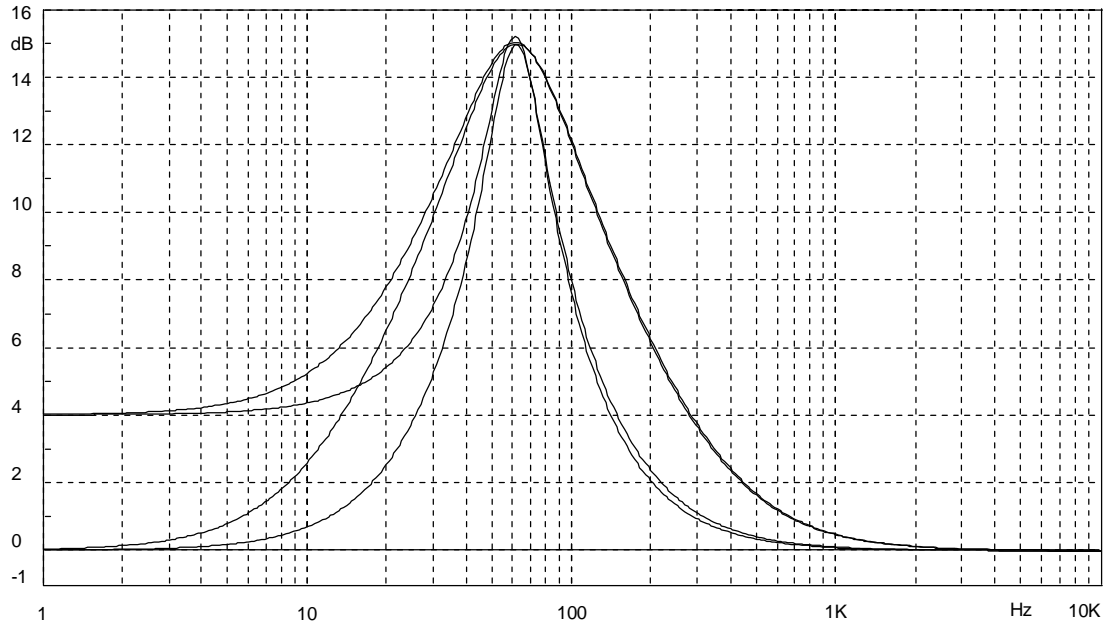


Figure 9. Quality factors @ boost = 15dB, $f_{\text{Center}} = 1\text{kHz}$ **Figure 10. Superposition of all EQ bands @ boost = 15dB**

2.6.2 DC-Mode

The filter stage 1 (62/100Hz) has a programmable +4dB DC-gain when the boost is set at +15dB (See Figure 11).

Figure 11. EQ band1, normal- and DC-mode @ boost = 15 dB, $f_{Center} = 62 \text{ Hz}$

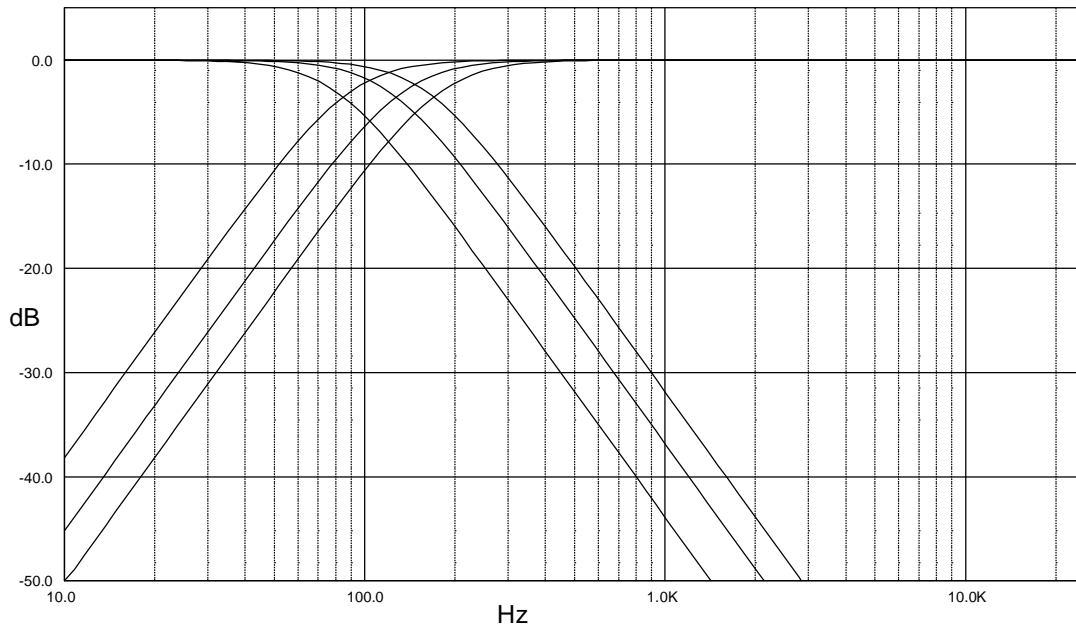


Note: The center frequency, Q, DC-mode and boost/cut can be set fully independently for each filter.

2.7 Subwoofer Application

There is one separate subwoofer output. A low-pass filter stage at this output allows the selection of three different frequencies: 80/120/160Hz. A high Pass Filter stage is present in the main path with selectable 90/135/180/215Hz frequencies. Both filters, the low-pass as well as the high-pass filter can be disabled and have but-terworth characteristics so that their cutoff frequencies are not equal but shifted by the factor 1.125 to get a flat frequency response (see Figure 12).

Figure 12. Subwoofer Application with Lowpass @ 80/120/160Hz and HighPass @ 90/135/180Hz



2.8 Spectrum analyzer

A fully integrated seven band spectrum analyzer with programmable quality factor is present in the IC (Figure 13).

The spectrum analyzer consists of seven band pass filters with a rectifier and sample capacitor which stores the maximum peak signal level since the last read cycle. This peak signal level can be read by a microprocessor at the SA_{out} pin. To allow easy interfacing to a microprocessor analog port, the output voltage at this pin is referred to device ground.

The microprocessor starts a read cycle when there is a clock edge going negative at the SA_{clk} input. On the following positive clock edges, the peak signal level for the band pass filters is subsequently switched to SA_{out}. Each analog output data is valid after the time $t_{SA\text{del}}$.

A reset of the sample capacitors is induced whenever SA_{clk} remains high for the time t_{intres} . Note that a proper reset requires the clock signal SA_{clk} to be held at high potential. Figure 13 shows the block diagram and Figure 14 illustrates the read cycle timing of the spectrum analyzer.

The spectrum analyzer minimum repeat time is 50ms.

2.8.1 Spectrum Analyzer Filters

Each filter is realized as a switched capacitor with a 2nd order frequency response. The center frequency of the filter stages are: 62, 157, 396, 1K, 2.51K, 6.34k and 16kHz. It is possible to choose between two different filter quality factors: 1.8 and 3.5.

Figure 13. Spectrum analyzer block diagram

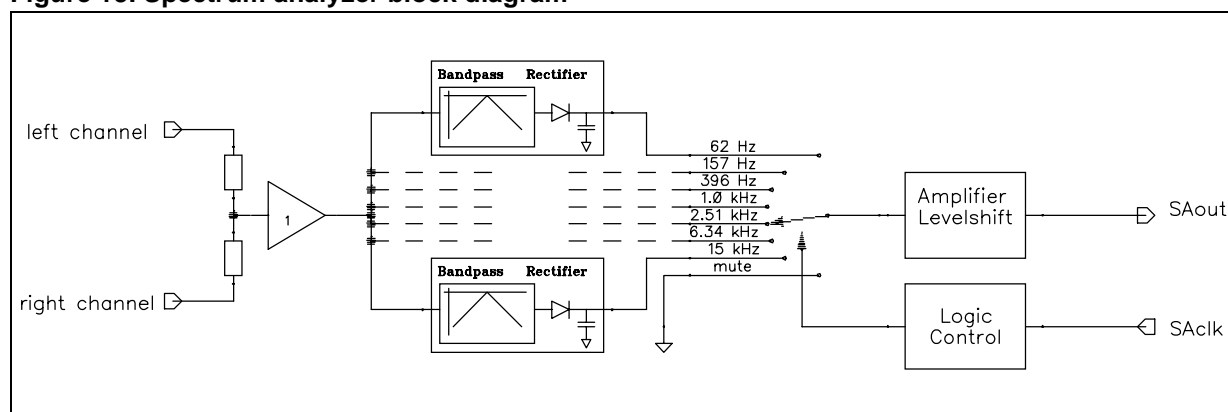
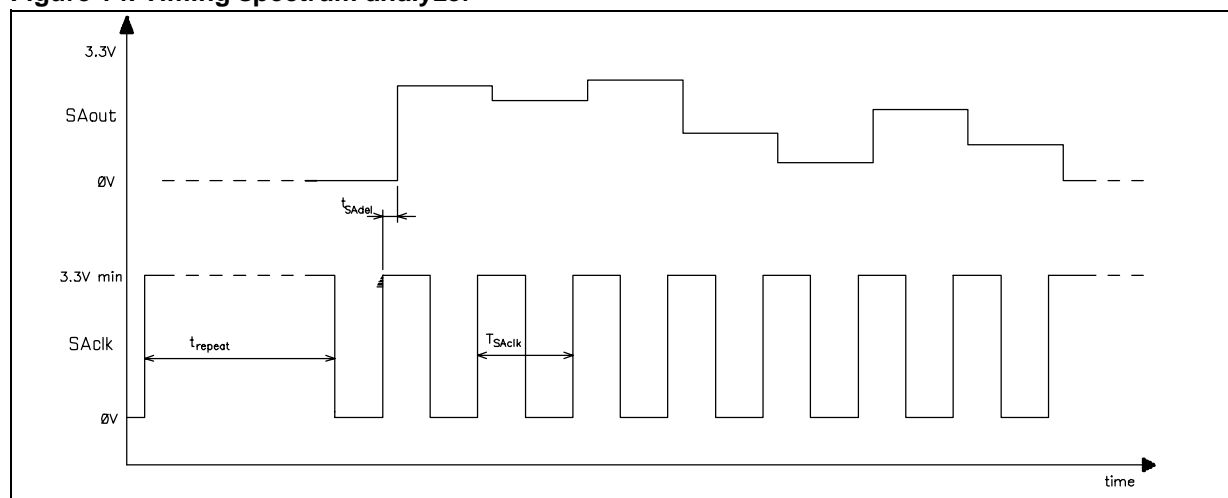


Figure 14. Timing spectrum analyzer



2.9 AC-coupling

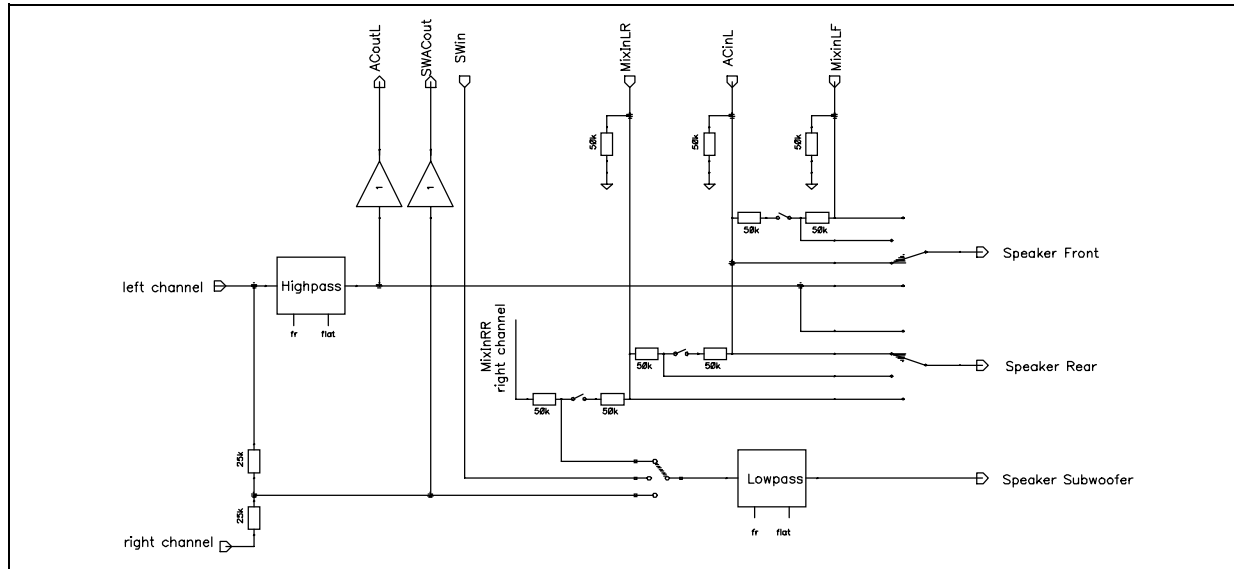
In some applications additional signal manipulations are desired. For this purpose an AC-coupling is placed before the speaker-attenuators, which can be activated or internally shorted by I²C-Bus. In short condition the input-signal of the speaker-attenuator is available at the AC-outputs. The input-impedance of this AC-inputs is 50kΩ. In addition there are Mix_{In} inputs available. With this inputs it is possible to mix an external signal to every speaker with a mixing ratio of 50% (see Figure 15).

The source of front and rear speaker can be set independently. As source is possible to choose:

- internal dc coupling (not recommended)
- external ac coupling using AC_{In} pins
- external ac coupling using Mix_{In} pins
- mixing of AC_{In} and Mix_{In} pins (mixing ratio: 50%)

If the Mix_{In} pins of the rear speaker are not used this inputs can be used as mixing inputs for the internal subwoofer filter.

Figure 15. AC/DC-coupling and Mix_{In} Inputs



2.10 Speaker-Attenuator stage

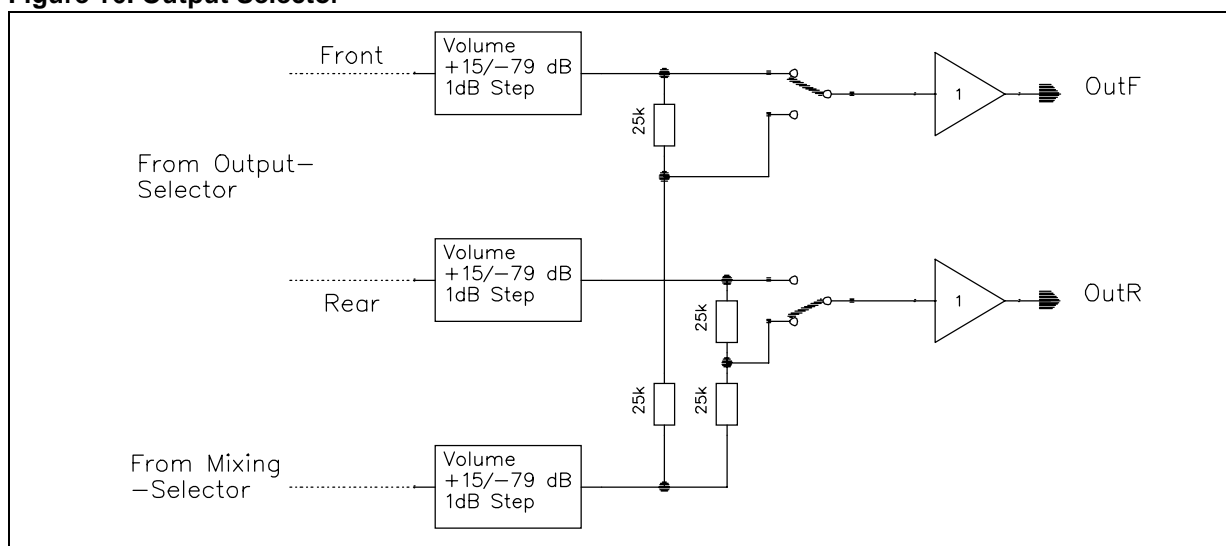
Each of the four speakers and the subwoofer output has a separate volume control in the range: +15... -79dB plus mute with a typical value of -90dB.

2.11 Output Mixer

A Mixing-stage is placed after each speaker gain/attenuator stage and can be set independently to mixing-mode.

Having a full volume control for the Mix-signal in the range:+15... -79dB plus mute with a typical value of -90dB, the stage offers a wide flexibility to adapt the mixing levels.

Figure 16. Output Selector



2.12 Audioprocessor Testing

During the Test Mode, which can be activated by setting bit I_2 of the subaddress byte **and** D_0 of the audioprocessor testing byte, several internal signals are available at the Navi pin. During this mode the input resistance of 100k Ω is disconnected from the pin. The internal signals available are shown in the Data-byte specification.

3 STERODECODER PART

3.1 Features:

- No external components necessary
- PLL with adjustment free, fully integrated VCO
- Automatic pilot dependent MONO/STEREO switching
- Very high suppression of intermodulation and interference
- Programmable Roll-Off compensation
- Dedicated RDS-Softmute
- Highcut and Stereoblend-characteristics programmable in a wide range
- FM/AM noiseblanker with several threshold controls
- Multipath-detector with programmable internal/external influence
- I²C-bus control of all necessary functions

Table 2. ELECTRICAL CHARACTERISTICS

V_S = 9V, de-emphasis time constant = 50µs, MPX input voltage V_{MPX} = 500mV (75kHz deviation), modulation frequency = 1kHz, input gain = 6dB, T_{amb} = 27°C, unless otherwise specified.

Symbol	Parameter	Test Conditions	Min.	Typ.	Max.	Unit
V _{in}	MPX Input Level	Input Gain = 3.5dB		0.5	1.25	V _{rms}
R _{in}	Input Resistance		70	100	130	kΩ
G _{min}	Min. Input Gain		1.5	3.5	4.5	dB
G _{max}	Max. Input Gain		8.5	11	12.5	dB
G _{step}	Step Resolution		1.75	2.5	3.25	dB
SVRR	Supply Voltage Ripple Rejection	V _{ripple} = 100mV, f = 1kHz		60		dB
α	Max. Channel Separation		30	50		dB
THD	Total Harmonic Distortion	f _{in} =1kHz, mono		0.02	0.3	%
$\frac{S+N}{N}$	Signal plus Noise to Noise Ratio	A-weighted, S = 2V _{rms}	80	91		dB

MONO/STEREO-SWITCH

V _{PTHST1}	Pilot Threshold Voltage	for Stereo, PTH = 1	10	15	25	mV
V _{PTHST0}	Pilot Threshold Voltage	for Stereo, PTH = 0	15	25	35	mV
V _{PTHMO1}	Pilot Threshold Voltage	for Mono, PTH = 1	7	12	17	mV
V _{PTHMO0}	Pilot Threshold Voltage	for Mono, PTH = 0	10	19	25	mV

PLL

Δf/f	Capture Range		0.5			%
------	---------------	--	-----	--	--	---

DEEMPHASIS and HIGHCUT

Table 2. ELECTRICAL CHARACTERISTICS (continued)

$V_S = 9V$, de-emphasis time constant = $50\mu s$, MPX input voltage $V_{MPX} = 500mV$ (75kHz deviation), modulation frequency = 1kHz, input gain = 6dB, $T_{amb} = 27^\circ C$, unless otherwise specified.

Symbol	Parameter	Test Conditions	Min.	Typ.	Max.	Unit
$\tau_{DeempFM}$	De-emphasis Time constants FM	$V_{LEVEL} \gg V_{HCH}$	25	50	75	μs
		$V_{LEVEL} \gg V_{HCH}$	44	62.5	80	μs
		$V_{LEVEL} \gg V_{HCH}$	50	75	100	μs
		$V_{LEVEL} \gg V_{HCH}$	70	100	130	μs
M_{FM}	Highcut Time constant Multiplier FM	$V_{LEVEL} \ll V_{HCL}$		3		
$\tau_{DeempAM}$	De-emphasis Time constants AM	$V_{LEVEL} \gg V_{HCH}$		37.5		μs
		$V_{LEVEL} \gg V_{HCH}$		47		μs
		$V_{LEVEL} \gg V_{HCH}$		56		μs
		$V_{LEVEL} \gg V_{HCH}$		75		μs
M_{AM}	High cut Time constant Multiplier AM	$V_{LEVEL} \ll V_{HCL}$		3.7		
REF5V	Internal Reference Voltage		4.7	5	5.3	V
L_{min}	min. LEVEL Gain		-1	0	+1	dB
L_{maxs}	max. LEVEL Gain		5	6	7	dB
L_{Gstep}	LEVEL Gain Step Resolution	see section 2.7	0.2	0.4	0.6	dB
$VSBL_{min}$	Min. Voltage for Mono	see section 2.8	17	20	23	%REF5V
$VSBL_{max}$	Max. Voltage for Mono	see section 2.8	62	70	78	%REF5V
$VSBL_{step}$	Step Resolution	see section 2.8	1.6	3.3	5.0	%REF5V
$VHCH_{min}$	Min. Voltage for NO Highcut	see section 2.9	77	42	47	%REF5V
$VHCH_{max}$	Max. Voltage for NO Highcut	see section 2.9	58	66	74	%REF5V
$VHCH_{step}$	Step Resolution	see section 2.9	4.2	8.4	12.6	%REF5V
$VHCL_{min}$	Min. Voltage for FULL High cut	see section 2.9	15	17	19	%VHCH
$VHCL_{max}$	Max. Voltage for FULL High cut	see section 2.9	29	33	37	%VHCH
$VHCL_{step}$	Step Resolution	see section 2.9	2.1	4.2	6.3	%REF5V
Carrier and harmonic suppression at the output						
$\alpha 19$	Pilot Signal $f=19kHz$		40	50		dB
$\alpha 38$	Subcarrier $f=38kHz$			75		dB
$\alpha 57$	Subcarrier $f=57kHz$			62		dB
$\alpha 76$	Subcarrier $f=76kHz$			90		dB

Table 2. ELECTRICAL CHARACTERISTICS (continued)

V_S = 9V, de-emphasis time constant = 50µs, MPX input voltage V_{MPX} = 500mV (75kHz deviation), modulation frequency = 1kHz, input gain = 6dB, T_{amb} = 27°C, unless otherwise specified.

Symbol	Parameter	Test Conditions	Min.	Typ.	Max.	Unit
Intermodulation (Note 1)						
α2	f _{mod} =10kHz, f _{spur} =1kHz			65		dB
α3	f _{mod} =13kHz, f _{spur} =1kHz			75		dB
Traffic Radio (Note 2)						
α57	Signal f=57kHz			70		dB
SCA - Subsidiary Communications Authorization (Note 3)						
α67	Signal f=67kHz			75		dB
ACI - Adjacent Channel Interference (Note 4)						
α114	Signal f=114kHz			95		dB
α190	Signal f=190kHz			84		dB

Notes to the Characteristics

Note 1. Intermodulation Suppression

$$\alpha_2 = \frac{V_o(\text{signal})(\text{at}1\text{kHz})}{V_o(\text{spurious})(\text{at}1\text{kHz})}; f_s = (2 \cdot 10\text{kHz}) - 19\text{kHz}$$

$$\alpha_3 = \frac{V_o(\text{signal})(\text{at}1\text{kHz})}{V_o(\text{spurious})(\text{at}1\text{kHz})}; f_s = (3 \cdot 13\text{kHz}) - 38\text{kHz}$$

measured with: 91% pilot signal; f_m = 10 kHz or 13 kHz.

Note 2. Traffic Radio (V.F.) Suppression

measured with: 91% stereo signal; 9% pilot signal; f_m=1kHz; 5% subcarrier (f=57kHz, f_m=23Hz AM, m=60%)

$$\alpha_{57}(\text{V.W.F.}) = \frac{V_o(\text{signal})(\text{at}1\text{kHz})}{V_o(\text{spurious})(\text{at}1\text{kHz} \pm 23\text{kHz})}$$

Note 3. SCA (Subsidiary Communications Authorization)

measured with: 81% mono signal; 9% pilot signal; f_m=1kHz; 10%SCA - subcarrier (f_s = 67kHz, unmodulated).

$$\alpha_{67} = \frac{V_o(\text{signal})(\text{at}1\text{kHz})}{V_o(\text{spurious})(\text{at}9\text{kHz})}; f_s = (3 \cdot 38\text{kHz}) - 67\text{kHz}$$

Note 4. ACI (Adjacent Channel Interference)

$$\alpha_{114} = \frac{V_o(\text{signal})(\text{at}1\text{kHz})}{V_o(\text{spurious})(\text{at}4\text{kHz})}; f_s = 110\text{kHz} - (3 \cdot 38\text{kHz})$$

$$\alpha_{190} = \frac{V_o(\text{signal})(\text{at}1\text{kHz})}{V_o(\text{spurious})(\text{at}4\text{kHz})}; f_s = 186\text{kHz} - (5 \cdot 38\text{kHz})$$

measured with: 90% mono signal; 9% pilot signal; $f_m=1\text{kHz}$; 1% spurious signal ($f_s = 110\text{kHz}$ or 186kHz , unmodulated).

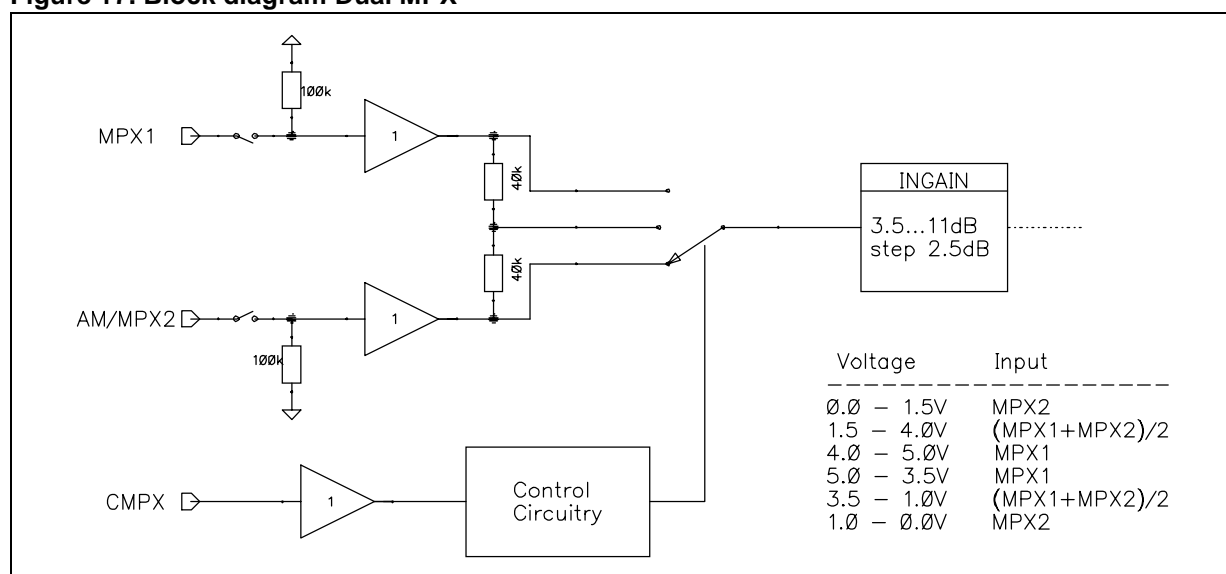
3.2 Dual MPX Usage

3.2.1 Feature Description

The TDA7406T is able to support a twin tuner concept via the Dual-MPX-Mode. The DC-Voltage at the CMPX-pin controls whether one or both MPX-signals are used to decode the stereo FM-signal. Therefore two window-comparators with a characteristic as shown in Figure 17 are implemented (Please note that the thresholds have a hysteresis of 500mV).

In this mode the stereodecoder high impedance-mute mutes both inputs in parallel.

Figure 17. Block diagram Dual MPX



NOISE BLANKER PART

Features:

- AM and FM mode
- internal 2nd order 140kHz high-pass filter for MPX path
- internal rectifier and filters for AM-IF path
- programmable trigger thresholds
- trigger threshold dependent on high frequency noise with programmable gain
- additional circuits for deviation- and fieldstrength-dependent trigger adjustment
- 4 selectable pulse suppression times for each mode
- programmable noise rectifier charge/discharge current

Table 3. ELECTRICAL CHARACTERISTICS

All parameters measured in FM mode if not otherwise specified.

Symbol	Parameter	Test conditions		Min.	Typ.	Max.	Unit
V _{TR}	Trigger Threshold ¹⁾	meas.with V _{PEAK} =0.9V	111		30		mV _{OP}
			110		35		mV _{OP}
			101		40		mV _{OP}
			100		45		mV _{OP}
			011		50		mV _{OP}
			010		55		mV _{OP}
			001		60		mV _{OP}
			000		65		mV _{OP}
V _{TRNOISE}	noise controlled Trigger Threshold	meas.with V _{PEAK} =1.5V	00		260		mV _{OP}
			01		220		mV _{OP}
			10		180		mV _{OP}
			11		140		mV _{OP}
V _{RECT}	Rectifier Voltage	V _{MPX} =0mV		0.5	0.9	1.3	V
		V _{MPX} =50mV, f=150kHz		1.5	1.7	2.1	V
		V _{MPX} =200mV, f=150kHz		2	2.5	2.9	V
V _{RECTDEV}	Deviation dependent Rectifier Voltage	meas.with V _{MPX} =500mV (75kHz dev.)	11	0.5	0.9 (off)	1.3	V _{OP}
			10	0.9	1.2	1.5	V _{OP}
			01	1.7	2.0	2.3	V _{OP}
			00	2.5	2.8	3.1	V _{OP}
V _{RECTFS}	Fieldstrength controlled Rectifier Voltage	meas.with V _{MPX} =0mV, V _{LEVEL} << V _{SBL} (fully mono)	11	0.5	0.9 (off)	1.3	V
			10	0.9	1.4	1.5	V
			01	1.7	1.9	2.3	V
			00	2.1	2.4	3.1	V

Table 3. ELECTRICAL CHARACTERISTICS (continued)

All parameters measured in FM mode if not otherwise specified.

Symbol	Parameter	Test conditions		Min.	Typ.	Max.	Unit
T _{SFM}	Suppression Pulse Duration FM	Signal HOLDN in Testmode	00		38		μ s
			01		25.5		μ s
			10		32		μ s
			11		22		μ s
T _{SAM}	Suppression Pulse Duration AM	Signal HOLDN in Testmode	00		1.2		ms
			01		800		μ s
			10		1.0		ms
			11		640		μ s
V _{RECTADJ}	Noise rectifier discharge adjust- ment	Signal PEAK in Testmode	00		0.3		V/ms
			01		0.8		
			10		1.3		
			11		2.0		
SR _{PEAK}	Noise rectifier charge	Signal PEAK in Testmode	0		10		mV/ μ s
			1		20		
V _{ADJMP}	Noise rectifier adjustment through Multipath	Signal PEAK in Testmode	00		0.3		V/ms
			01		0.5		
			10		0.7		
			11		0.9		
R _{AMIF}	AM IF Input resistance			35	50	65	k Ω
G _{AMIF,min}	min. gain AM IF	Signal AM-RECTIFIER in Test- mode			6		dB
G _{AMIF,max}	max. gain AM IF				20		dB
G _{AMIF,step}	step gain AM IF				2		dB
f _{AMIF,min}	min. f _c AM IF	Signal AM-RECTIFIER in Test- mode			14		kHz
f _{AMIF,max}	max. f _c AM IF				56		kHz

Notes: 1. All thresholds are measured using a pulse with $T_R = 2 \mu$ s, $T_{HIGH} = 2 \mu$ s and $T_F = 10 \mu$ s. The repetition rate must not increase the PEAK voltage.

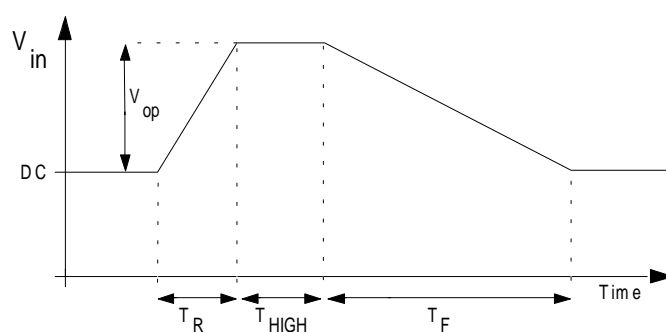


Figure 18. Trigger Threshold vs. V_{PEAK}

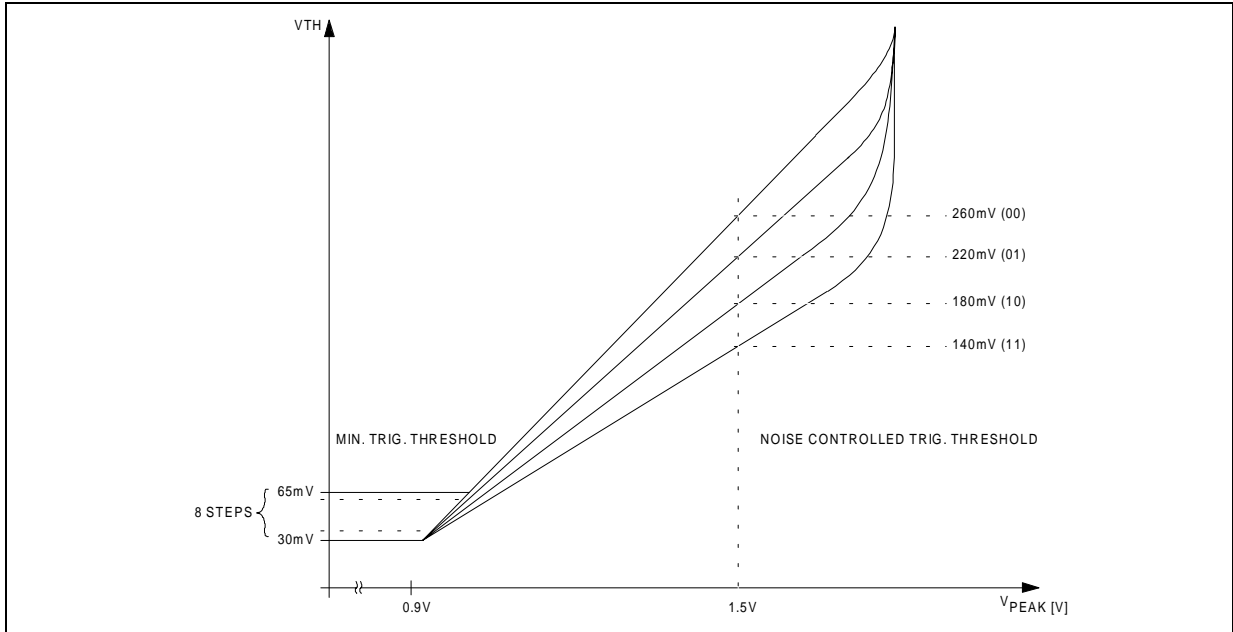


Figure 19. Deviation Controlled Trigger Adjustment

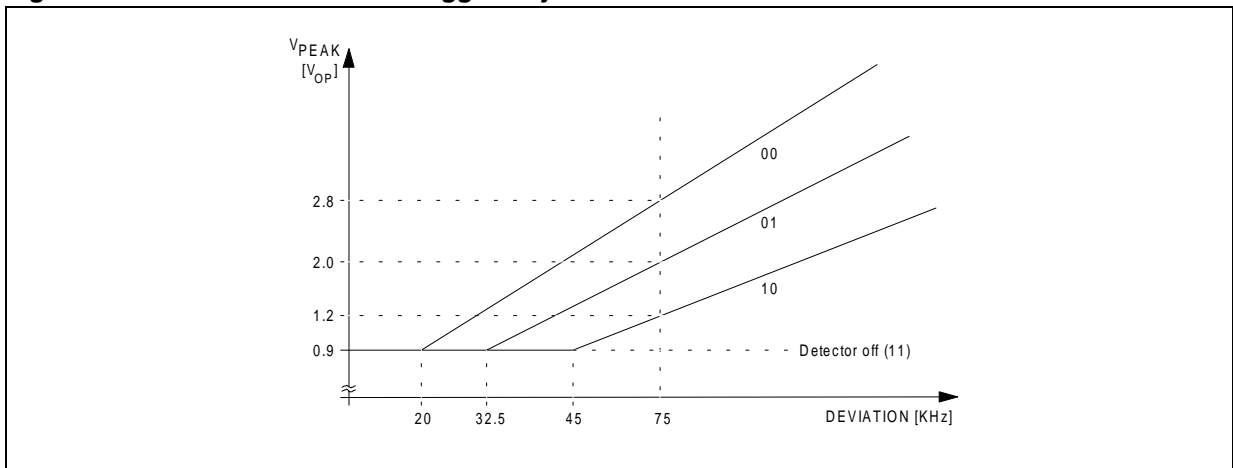
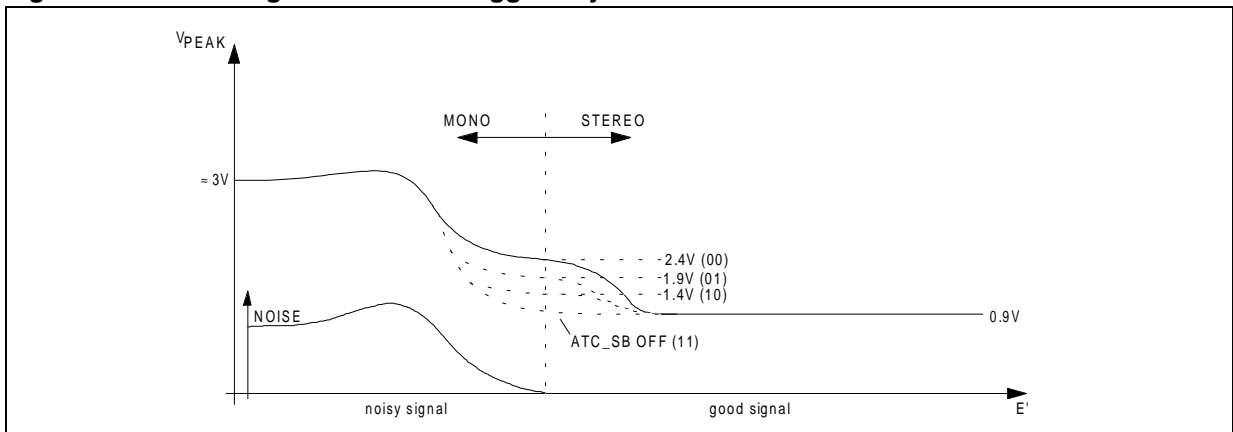


Figure 20. Fieldstrength Controlled Trigger Adjustment



MULTIPATH DETECTOR

Features:

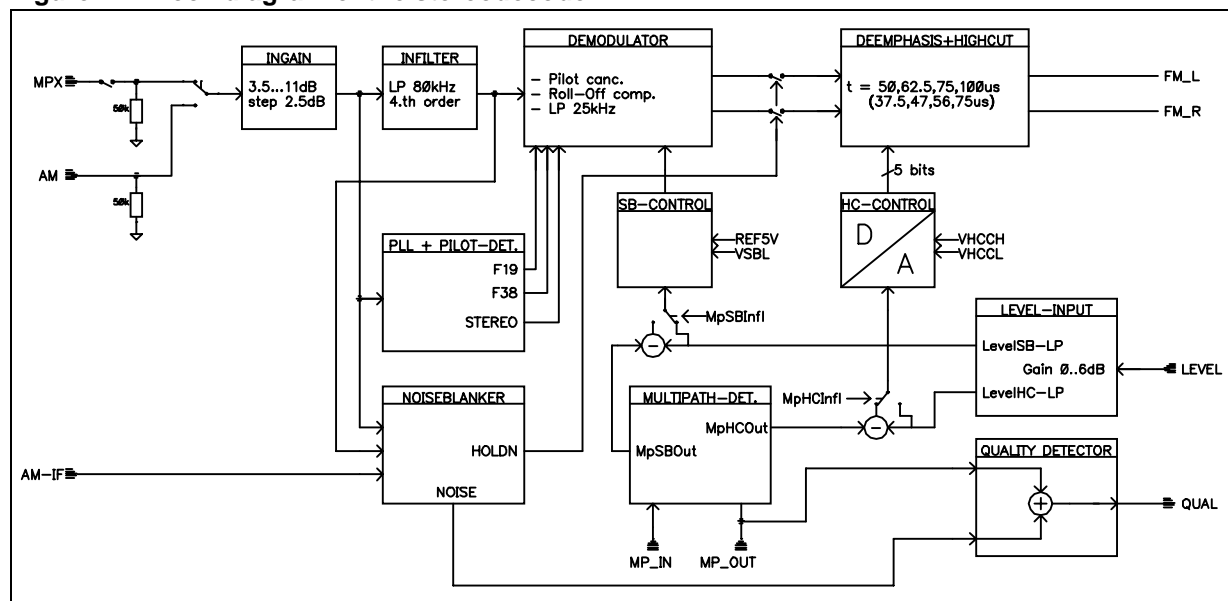
- internal 19kHz band-pass filter
- programmable band-pass- and rectifier-gain
- selectable internal influence on Stereoblend and/or Highcut

Table 4. ELECTRICAL CHARACTERISTICS

Symbol	Parameter	Test Conditions		Min.	Typ.	Max.	Unit
f _{CMP}	Center frequency of Multipath-Bandpass	stereodecoder locked on Pilot tone			19		kHz
G _{BPMP}	Bandpass Gain	G1			6		dB
		G2			12		dB
		G3			16		dB
		G4			18		dB
G _{RECTMP}	Rectifier Gain	G1			7.6		dB
		G2			4.6		dB
		G3			0		dB
I _{CHMP}	Rectifier Charge Current				0.25 0.5		µA
I _{DISMP}	Rectifier Discharge Current				4		mA
Quality Detector							
A	Multipath Influence Factor		00		0.70		
			01		0.85		
			10		1.00		
			11		1.15		

4 FUNCTIONAL DESCRIPTION OF STEREODECODER

Figure 21. Block diagram of the stereodecoder



The stereodecoder-part of the TDA7406T (see Fig. 25) contains all functions necessary to demodulate the MPX-signal like pilot tone-dependent MONO/STEREO-switching as well as “stereoblend” and “highcut”. Adaptations like programmable input gain, roll-off compensation, selectable de-emphasis time constant and a programmable field strength input allow to use different IF-devices.

4.1 Stereodecoder-Mute

The TDA7406T has a fast and easy to control RDS-Mute function which is a combination of the audioprocessor's SoftMute and the high-ohmic mute of the stereodecoder. If the stereodecoder is selected and a SoftMute command is sent (or activated through the SM-pin) the stereodecoder will be set automatically to the high-ohmic mute condition after the audio-signal has been soft muted. Hence a checking of alternate frequencies could be performed. Additionally the PLL can be set to “Hold”-mode, which disables the PLL input during the mute time. To release the system from the mute condition simply the unmute-command must be sent: the stereodecoder is unmuted immediately and the audioprocessor is softly unmuted. Fig. 26 shows the output-signal V_O as well as the internal stereodecoder mute signal. This influence of SoftMute on the stereodecoder mute can be switched off by setting bit 3 of the SoftMute byte to “0”. A stereodecoder mute command (bit 0, stereodecoder byte set to “1”) will set the stereodecoder **in any case** independently to the high-ohmic mute state.

If any other source than the stereodecoder is selected the decoder remains muted and the MPX-pin is connected to V_{ref} to avoid any discharge of the coupling capacitor through leakage currents. No further mute command should be applied.

Figure 22. Signals during stereodecoder's SoftMute

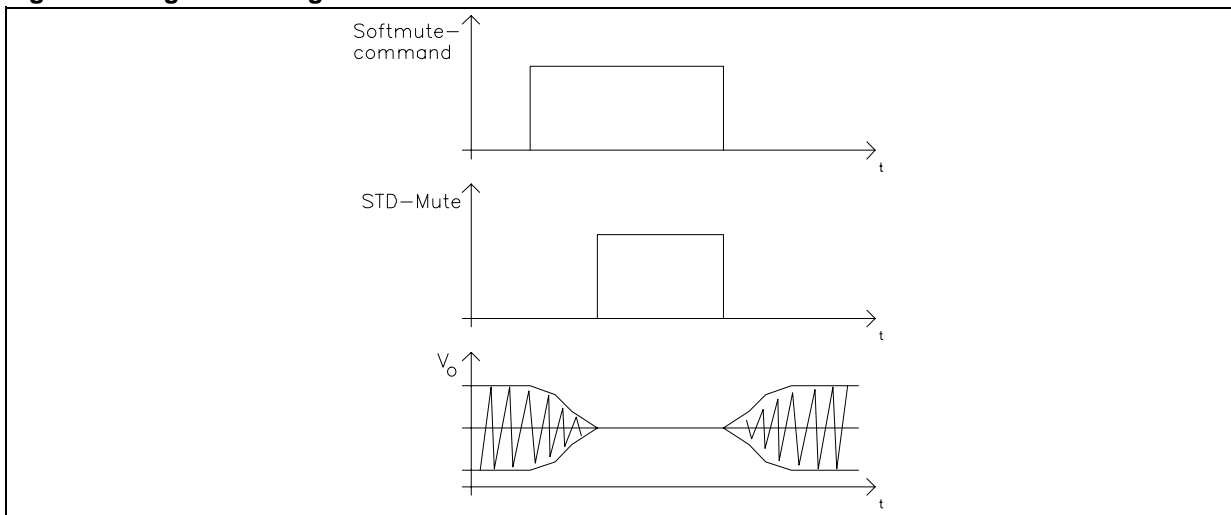
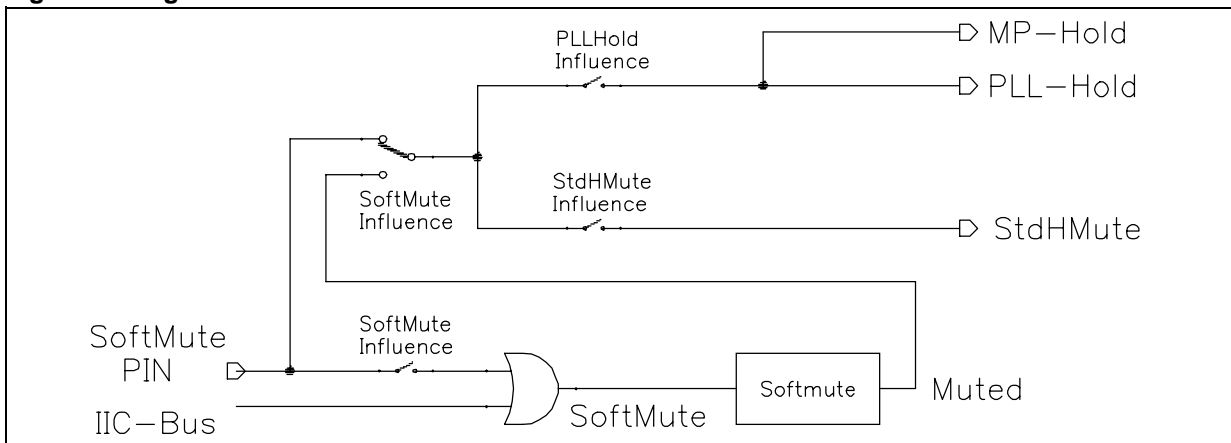


Figure 23. Signal-Control via SoftMute-Pin



4.2 2.2. InGain + InFilter

The InGain stage allows to adjust the MPX-signal to an internal magnitude of about $1V_{rms}$ which is the recommended value. The 4.th order input filter has a corner frequency of 80kHz and is used to attenuate spikes and noise and acts as an anti-aliasing filter for the following switch capacitor filters.

4.3 Demodulator

In the demodulator block the left and the right channel are separated from the MPX-signal. In this stage also the 19-kHz pilot tone is cancelled. For reaching a high channel separation the TDA7406T offers an I²C-bus programmable roll-off adjustment which is able to compensate the lowpass behavior of the tuner section. If the tuner's attenuation at 38kHz is in a range from 7.2% to 31.0% the TDA7406T needs no external network in front of the MPX-pin. Within this range an adjustment to obtain at least 40dB channel separation is possible. The bits for this adjustment are located together with the fieldstrength adjustment in one byte. This gives the possibility to perform an optimization step during the production of the car radio where the channel separation and the fieldstrength control are trimmed. The setup of the Stereoblend characteristics which is programmable in a wide range is described in 4.8.

4.4 De-emphasis and Highcut

The de-emphasis-lowpass allows to choose a time constant between 37.5 and 100 μ s. The highcut control range will be $2 \times \tau_{Deemp}$ or $2.7 \times \tau_{Deemp}$ dependent on the selected time constant (see programming section). The bit D7 of the highcut-byte will shift time constant and range.

Inside the highcut control range (between VHCH and VHCL) the LEVEL signal is converted into a 5 bit word which controls the lowpass time constant between $\tau_{Deemp} \dots 3 (3.7) \times \tau_{Deemp}$. Thereby the resolution will remain always 5 bits independently of the absolute voltage range between the VHCH- and VHCL-values. In addition the maximum attenuation can be fixed between 2 and 10dB.

The highcut function can be switched off by I²C-bus (bit D7, Highcut byte set to "0").

The setup of the highcut characteristics is described in 4.9.

4.5 PLL and Pilot tone-Detector

The PLL has the task to lock on the 19kHz pilot tone during a stereo-transmission to allow a correct demodulation. The included pilot tone-detector enables the demodulation if the pilot tone reaches the selected pilot tone threshold V_{PTHST} . Two different thresholds are available. The detector output (signal STEREO, see Block diagram) can be checked by reading the status byte of the TDA7406T via I²C-bus. During a Softmute the PLL can be set into "Hold"-mode which freezes the PLL's state (bit D₄, Softmute byte). After releasing the Softmute the PLL will again follow the input signal only by correcting the phase error.

4.6 Fieldstrength Control

The fieldstrength input is used to control the highcut- and the stereoblend-function. In addition the signal can be also used to control the noiseblanker thresholds and as input for the multipath detector. These additional functions are described in sections 5.3 and 6.

4.7 LEVEL-Input and -Gain

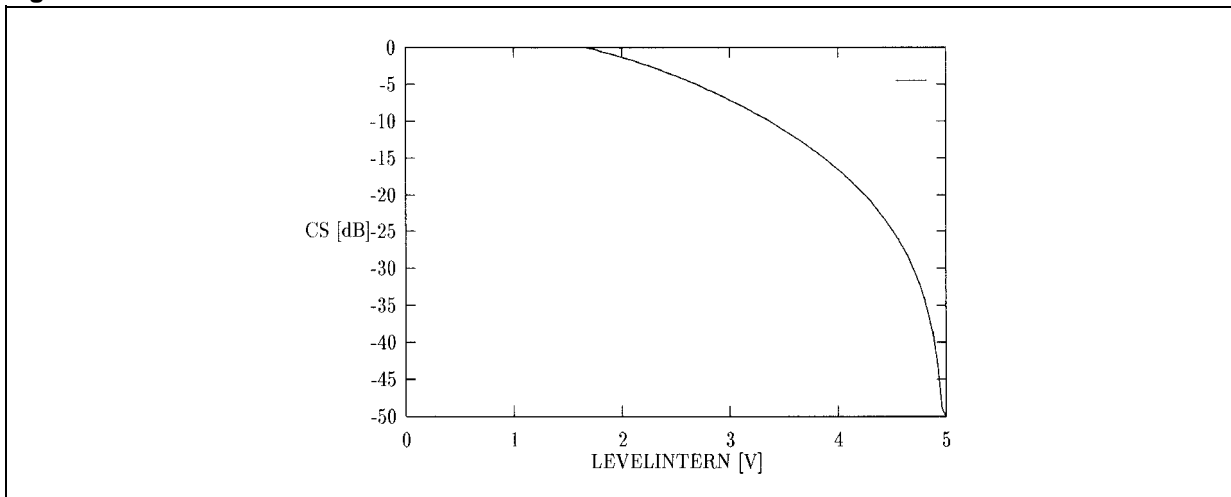
To suppress undesired high frequency modulation on the highcut- and stereoblend-control signal the LEVEL signal is lowpass filtered firstly. The filter is a combination of a 1.st-order RC-lowpass at 53kHz (working as anti-aliasing filter) and a 1.st-order switched-capacitor-lowpass at 2.2kHz. The second stage is a programmable gain stage to adapt the LEVEL signal internally to different IF-devices (see Testmode section 5: LEVELHCC). The gain is widely programmable in 16 steps from 0dB to 6dB (step=0.4dB). These 4 bits are located together with the Roll-Off bits in the "Stereodecoder-Adjustment"-byte to simplify a possible adjustment during the production of the car radio. This signal controls directly the Highcut stage whereas the signal is filtered again ($f_c=100$ Hz) before the stereoblend stage (see fig. 24).

4.8 Stereoblend Control

The stereoblend control block converts the internal LEVEL-voltage (LEVELSB) into an demodulator compatible analog signal which is used to control the channel separation between 0dB and the maximum separation. Internally this control range has a fixed upper limit which is the internal reference voltage REF5V. The lower limit can be programmed between 20 and 70% of REF5V in 3.3% steps (see figs.24, 25).

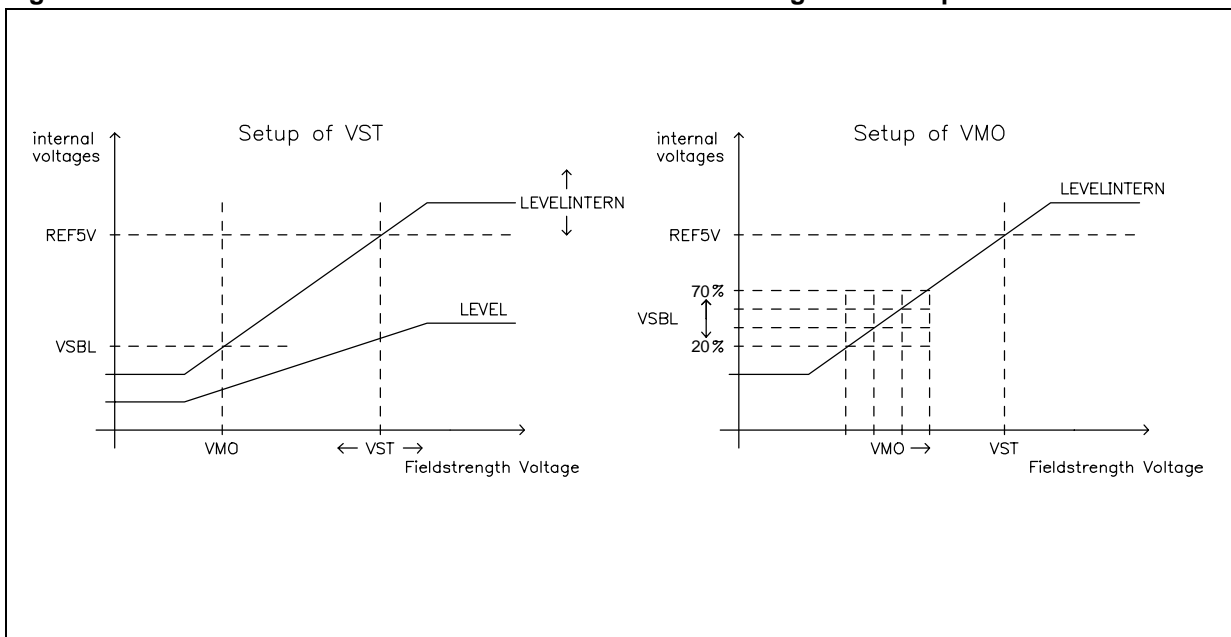
To adjust the external LEVEL-voltage to the internal range two values must be defined: the LEVEL gain LG and VSBL (see fig. 25). At the point of full channel separation the external level signal has to be amplified so that internally it becomes equal to REF5V. The second point (e.g. 10dB channel sep.) is then adjusted with the VSBL voltage.

Figure 24. Internal stereoblend characteristics



The gain can be programmed through 4 bits in the "Stereodecoder-Adjustment"-byte. All necessary internal reference voltages like REF5V are derived from a bandgap circuit. Therefore they have a temperature coefficient near zero.

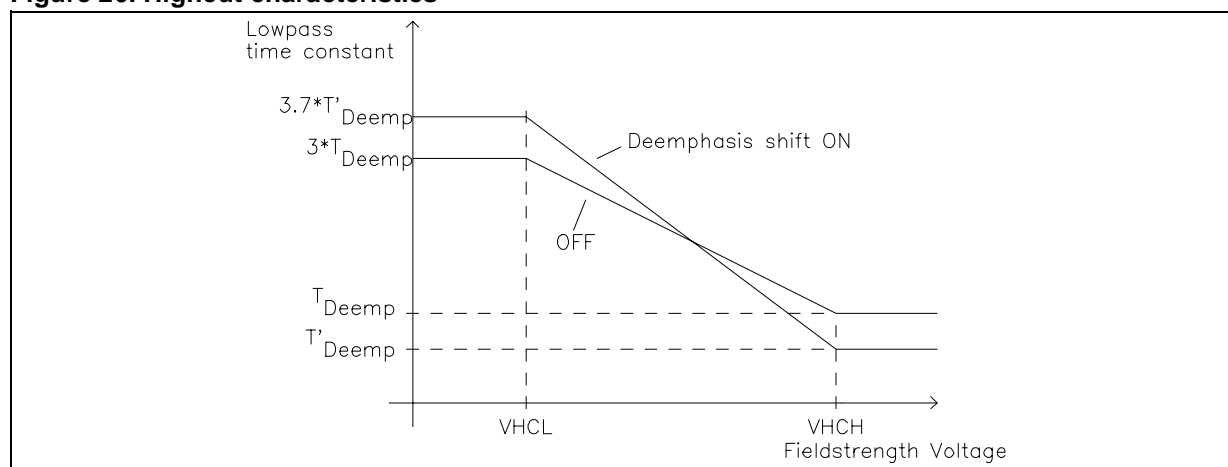
Figure 25. Relation between internal and external LEVEL-voltages for setup of Stereoblend



4.9 Highcut Control

The highcut control set-up is similar to the stereoblend control set-up: the starting point VHCH can be set with 2 bits to be 42, 50, 58 or 66% of REF5V whereas the range can be set to be 17, 22, 28 or 33% of VHCH (see fig. 26).

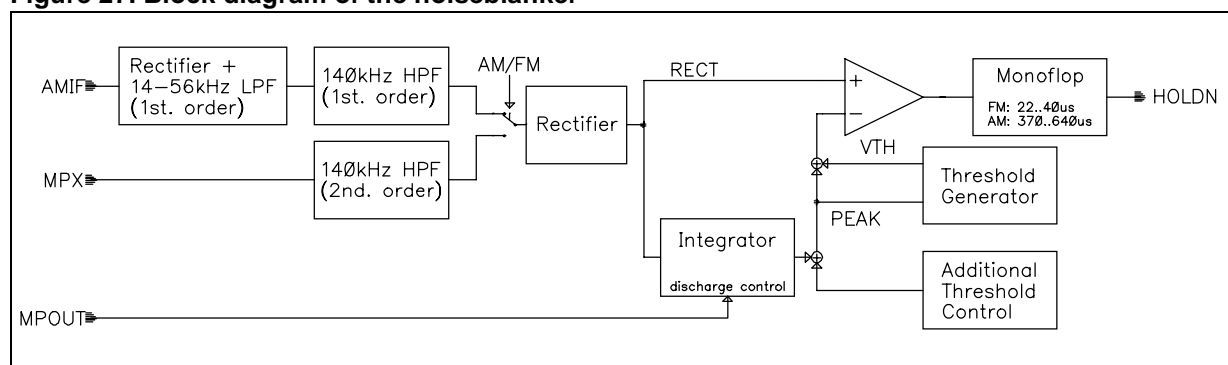
Figure 26. Highcut characteristics



5 FUNCTIONAL DESCRIPTION OF THE NOISEBLANKER

In the automotive environment the MPX-signal as well as the AM-signal is disturbed by spikes produced by the ignition and other radiating sources like the wiper-motor. The aim of the noiseblanker part is to cancel the audible influence of the spikes. Therefore the output of the stereodecoder is held at the actual voltage for a time between 22 and 38 μ s in FM (370 and 645 μ s in AM-mode). The block diagram of the noiseblanker is given in fig.27.

Figure 27. Block diagram of the noiseblanker



In a first stage the spikes must be detected but to avoid a wrong triggering on high frequency (white) noise a complex trigger control is implemented. Behind the trigger stage a pulse former generates the "blanking"-pulse.

5.1 Trigger Path FM

The incoming MPX signal is highpass-filtered, amplified and rectified. This second order highpass-filter has a corner-frequency of 140kHz. The rectified signal, RECT, is integrated (lowpass filtered) to generate a signal called PEAK. The DC-charge/discharge behavior can be adjusted as well as the transient behavior (MP-discharge control). Also noise with a frequency 140kHz increases the PEAK voltage. The PEAK voltage is fed to a threshold generator, which adds to the PEAK-voltage a DC-dependent threshold VTH. Both signals, RECT and PEAK+VTH are fed to a comparator which triggers a re-triggerable flip-flop. The flip-flop's output activates the sample-and-hold circuits in the signal path for the selected duration.

5.2 Noise Controlled Threshold Adjustment (NCT)

There are mainly two independent possibilities for programming the trigger threshold:

1. the low threshold in 8 steps (bits D1 to D3 of the noiseblanker-byte I)
2. and the noise adjusted threshold in 4 steps (bits D4 and D5 of the noiseblanker-byte I, see fig. 19).

The low threshold is active in combination with a good MPX signal without noise; the PEAK voltage is less than 1V. The sensitivity in this operation is high.

If the MPX signal is noisy (low fieldstrength) the PEAK voltage increases due to the higher noise, which is also rectified. With increasing of the PEAK voltage the trigger threshold increases, too. This gain is programmable in 4 steps (see fig. 22).

5.3 Additional Threshold Control Mechanism

5.3.1 Automatic Threshold Control by the Stereoblend voltage

Besides the noise controlled threshold adjustment there is an additional possibility for influencing the trigger threshold which depends on the stereoblend control.

The point where the MPX signal starts to become noisy is fixed by the RF part. Therefore also the starting point of the normal noise-controlled trigger adjustment is fixed (fig. 20). In some cases the behavior of the noiseblanker can be improved by increasing the threshold even in a region of higher fieldstrength. Sometimes a wrong triggering occurs for the MPX signal often shows distortion in this range which can be avoided even if using a low threshold. Because of the overlap of this range and the range of the stereo/mono transition it can be controlled by stereoblend. This increase of the threshold is programmable in 3 steps or switched off.

5.3.2 Over Deviation Detector

If the system is tuned to stations with a high deviation the noiseblanker can trigger on the higher frequencies of the modulation or distortion. To avoid this behavior, which causes audible noise in the output signal, the noiseblanker offers a deviation-dependent threshold adjustment. By rectifying the MPX signal a further signal representing the actual deviation is obtained. It is used to increase the PEAK voltage. Offset and gain of this circuit are programmable in 3 steps with the bits D6 and D7 of the noiseblanker-byte I (bit combination '00' turns off the detector, see fig. 19).

5.3.3 Multipath-Level

To react on high repetitive spikes caused by a Multipath-situation, the discharge-time of the PEAK voltage can be decreased depending on the voltage-level at pin MP_{out}. The TDA7406T offers a linear as well as a threshold driven control. The linear influence of the Multipath-Level on the PEAK-signal (D₇ of Multipath-Control-Byte) gives a discharge slewrate of 1V/ms¹. The second possibility is to activate the threshold driven discharge which switches on the 18kOhm discharge if the Multipath-Level is below 2.5V (D₇ of noiseblanker-byte II-byte).

¹ The slewrate is measured with R_{Discharge}=infinite and V_{MPout}=2.5V

5.3.4 AM mode of the Noiseblanker

The TDA7406T noiseblanker is also suitable for AM noise cancelling. The detector uses in AM mode the 450kHz unfiltered IF-output of the tuner for spike detection. A combination of programmable gain-stage and lowpass-filter forms an envelope detector which drives the noiseblanker's input via a 120kHz 1.st order highpass. In order to blank the whole spike in AM mode the hold-times of the sample and hold circuit are much longer then in FM (640µs to 1.2ms). All threshold controls can be used like in FM mode.

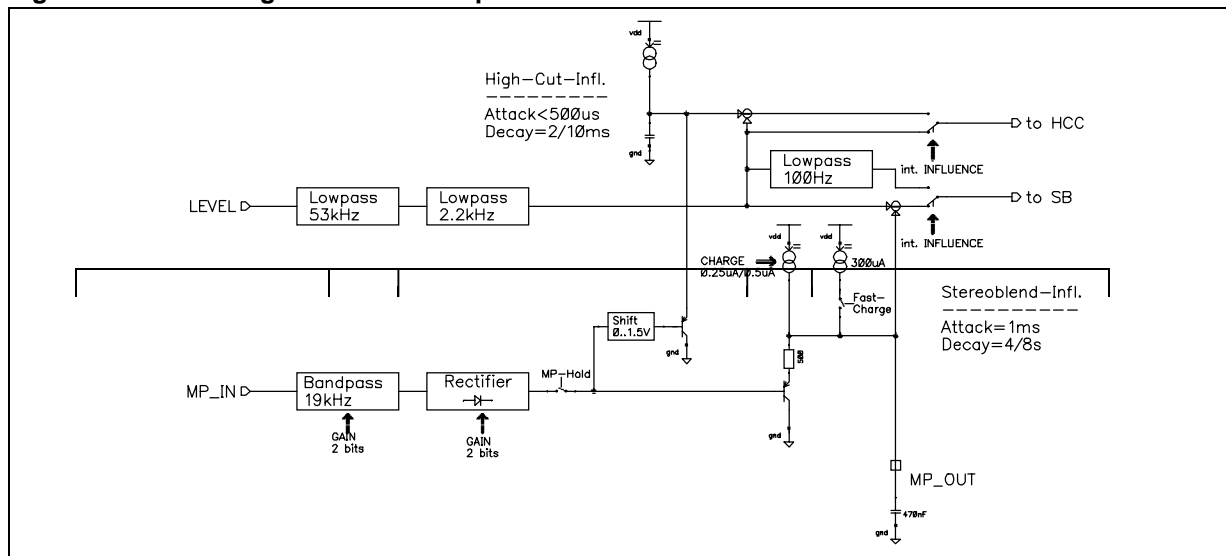
6 FUNCTIONAL DESCRIPTION OF THE MULTIPATH-DETECTOR

Using the Multipath-Detector the audible effects of a multipath condition can be minimized. A multipath-condition is detected by rectifying the spectrum around 19kHz in the fieldstrength signal. An external capacitor is used to define the attack- and decay-times for the Stereoblend (see block diagram, fig. 32). Due to the very small charge currents this capacitor should be a low leakage current type (e.g ceramic). Using this configuration an adaptation to the user's requirement is possible without effecting the "normal" fieldstrength input (LEVEL) for the stereodecoder. This application is given in fig. 28. Another (internal) time constant is used to control the

Highcut through the multipath detector

Selecting the "internal influence" in the configuration byte the Stereo-Blend and/or the Highcut is automatically invoked during a multipath condition according to the voltage appearing at the MP_OUT-pin.

Figure 28. Block diagram of the Multipath-Detector



7 QUALITY DETECTOR

The TDA7406T offers a quality detector output which gives a voltage representing the FM-reception conditions. To calculate this voltage the MPX-noise and the multipath-detector output are summed according to the following formula:

$$V_{Qual} = 1.6 (V_{Noise} - 0.8 \text{ V}) + a (\text{REF5V} - V_{Mput}).$$

The noise-signal is the PEAK-signal without additional influences (see noiseblanker description). The factor 'a' can be programmed from 0.7 to 1.15. The output is a low impedance output able to drive external circuitry as well as simply fed to an AD-converter for RDS applications.

8 TESTMODE

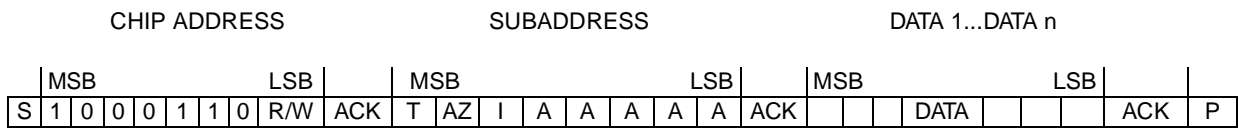
During the Testmode, which can be activated by setting bit I2 of the subaddress byte and bit D1 of the stereo-decoder testing-byte, several internal signals are available at the FD2R+ pin. During this mode the input resistance of 100kOhm is disconnected from the pin. The internal signals available are shown in the Data-byte specification

9 I²C BUS INTERFACE

9.1 Interface Protocol

The interface protocol comprises:

- a start condition (S)
- a chip address byte (the LSB bit determines read / write transmission)
- a subaddress byte
- a sequence of data (N-bytes + acknowledge)
- a stop condition (P)



S = Start

R/W = "0" -> Receive-Mode (Chip could be programmed by μP)

"1" -> Transmission-Mode (Data could be received by μP)

ACK = Acknowledge

P = Stop

MAX CLOCK SPEED 500kbits/s

9.1.1 Auto increment

If bit I in the subaddress byte is set to "1", the auto increment of the subaddress is enabled.

9.1.2 TRANSMITTED DATA (send mode)

MSB						LSB	
X	X	X	X	X	P	ST	SM

SM = Soft mute activated

ST = Stereo

P = Pause

X = Not Used

The transmitted data is automatically updated after each ACK.

Transmission can be repeated without new chip address.

9.1.3 Reset Condition

A Power-On-Reset is invoked if the Supply-Voltage is below than 3.5V. After that, the following data is written automatically into the registers of all subaddresses:

MSB							LSB
1	1	1	1	1	1	1	0

The programming after POR is marked bold-face / underlined in the programming tables.

With this programming all the outputs are muted to V_{REF} ($V_{OUT} = V_{DD}/2$).

9.2 SUBADDRESS (receive mode)

1MSB			LSB					FUNCTION
I ₂	I ₁	I ₀	A ₄	A ₃	A ₂	A ₁	A ₀	
0 1								Audioprocessor Testmode off on
	0 1							AutoZero Remain off on
		0 1						Auto-Increment Mode off on
			0	0	0	0	0	Subaddress Source Selector
			0	0	0	0	1	Loudness
			0	0	0	1	0	Volume
			0	0	0	1	1	EQ Filter 1 (62/100Hz)
			0	10	1	0	0	EQ Filter 2 (157Hz)
			0	0	1	0	1	EQ Filter 3 (396Hz)
			0	0	1	1	0	EQ Filter 4 (1kHz)
			0	0	1	1	1	EQ Filter 5 (2.51kHz)
			0	1	0	0	0	EQ Filter 6 (4/6.34kHz)
			0	1	0	0	1	EQ Filter 7 (15/16kHz)
			0	1	0	1	0	Mixing Programming
			0	1	0	1	1	SoftMute
			0	1	1	0	0	Subwoofer / Spectrum analyzer / HighPass
			0	1	1	0	1	Configuration Audioprocessor I
			0	1	1	1	0	Configuration Audioprocessor II
			0	1	1	1	1	Speaker attenuator LF
			1	0	0	0	0	Speaker attenuator RF
			1	0	0	0	1	Speaker attenuator LR
			1	0	0	1	0	Speaker attenuator RR
			1	0	0	1	1	Subwoofer attenuator
			1	0	1	0	0	Mixing Level Control
			1	0	1	0	1	Testing Audioprocessor
			1	0	1	1	0	Stereodecoder
			1	0	1	1	1	Noise-Blanker I
			1	1	0	0	0	Noise-Blanker II
			1	1	0	0	1	AM / AM-Noiseblanker
			1	1	0	1	0	High-Cut Control
			1	1	0	1	1	Fieldstrength & Quality
			1	1	1	0	0	Multipath-Detector
			1	1	1	0	1	Stereodecoder Adjustment
			1	1	1	1	0	Configuration Stereodecoder
			1	1	1	1	1	Testing Sterodecoder

9.3 DATA BYTE SPECIFICATION

The status after Power-On-Reset is marked bold-face / underlined in the programming tables.

Table 5. Input Selector (0)

MSB							LSB	FUNCTION
D ₇	D ₆	D ₅	D ₄	D ₃	D ₂	D ₁	D ₀	
					0	0	0	Source Selector CDC/PD
					0	0	1	CD
					0	1	0	MD
					0	1	1	Tape
					1	0	0	Phone
					1	0	1	Navi
					1	1	0	<u>Tuner</u>
					1	1	1	<u>TIM</u>
	0	0	0	0				Input Gain 0dB
	0	0	0	1				1dB
	:	:	:	:				:
	1	1	1	0				14dB
	1	1	1	1				<u>15dB</u>
0								Mute off
1								<u>on</u>

Table 6. Loudness (1)

MSB							LSB	FUNCTION
D ₇	D ₆	D ₅	D ₄	D ₃	D ₂	D ₁	D ₀	
			0	0	0	0	0	Attenuation 0 dB
			0	0	0	0	1	-1 dB
			:	:	:	:	:	:
			0	1	1	1	0	-14 dB
			0	1	1	1	1	-15 dB
			:	:	:	:	:	:
			1	0	0	1	1	-19 dB
			:	:	:	:	:	not allowed
	0	0						Center Frequency 200Hz
	0	1						400Hz
	1	0						600Hz
	1	1						<u>800Hz</u>
0								Loudness Order First Order
1								<u>Second Order</u>

Table 7. Volume (2)

MSB							LSB		ATTENUATION
D ₇	D ₆	D ₅	D ₄	D ₃	D ₂	D ₁	D ₀		
0	0	0	0	0	0	0	0	Gain/Attenuation (+32.0dB)	
0	0	0	0	0	0	0	1	(+31.5dB)	
:	:	:	:	:	:	:	:	:	
0	0	0	1	1	0	0	0	+20.0dB	
0	0	0	1	1	0	0	1	+19.5dB	
0	0	0	1	1	0	1	0	+19.0dB	
:	:	:	:	:	:	:	:	:	
0	0	1	1	1	1	1	1	+0.5dB	
0	1	0	0	0	0	0	0	0.0dB	
0	1	0	0	0	0	0	1	-0.5dB	
:	:	:	:	:	:	:	:	:	
1	1	0	1	1	1	1	0	<u>-79.0dB</u>	
1	1	0	1	1	1	1	1	-79.5dB	

Note: It is not recommended to use a gain more than 20dB for system performance reason. In general, the max. gain should be limited by software to the maximum value, which is needed for the system.

Table 8. Equalizer (3,4,5,6,7,8,9)

MSB							LSB		FUNCTION
D ₇	D ₆	D ₅	D ₄	D ₃	D ₂	D ₁	D ₀		
			0	0	0	0	0	Equalizer cut/boost level	
			0	0	0	0	1	-15dB	
			:	:	:	:	:	-14dB	
			0	1	1	1	0	:	
			0	1	1	1	1	-1dB	
			1	1	1	1	1	0dB	
			1	1	1	1	1	0dB	
			1	1	1	1	0	<u>+1dB</u>	
			:	:	:	:	:	:	
			1	0	0	0	1	+14dB	
			1	0	0	0	0	+15dB	
	0	0						Equalizer Q-Factor	
	0	1						2.2	
	1	0						1.8	
	1	1						1.4	
								1.0	
0								Equalizer Center Frequency (only Subaddresses 3,8,9)	
1								62Hz(addr 3)/4kHz(addr 8)/15kHz(addr 9)	
								<u>100Hz(addr 3)/6.24kHz(addr 8)/16kHz(addr 9)</u>	
0								DC mode EQ Band 1 (62/100 Hz, Subaddress. 4!)	
1								on	
								<u>off</u>	

Table 9. Mixing Programming (10)

MSB							LSB	FUNCTION
D7	D6	D5	D4	D3	D2	D1	D0	
							0 1	Mixing Mute enable
					0 0 1 1	0 1 0 1		Mixing Source Beep Phone Navi Tuner / TIM
	0 1	0 1	0 1	0 1				Mixing Target Speaker LF off Speaker LF on Speaker RF off Speaker RF on Speaker LR off Speaker LR on Speaker RR off Speaker RR on
1								<u>must be "1"</u>

Table 10. SoftMute (11)

MSB							LSB	FUNCTION
D7	D6	D5	D4	D3	D2	D1	D0	
							0 1	SoftMute On (Mute) Off
					0 0 1 1	0 1 0 1		SoftMute Time Mute time = 0.48ms Mute time = 0.96ms Mute time = 123ms Mute time = 324 ms
				0 1				Influence on Stereodecoder Highohmic-Mute on off
			0 1					Influence on Pilot-detector Hold and MP-Hold on off
		0 1						Influence on SoftMute on off
0 0 1 1	0 1 0 1							Beep Frequencies 600 Hz 780 Hz 1.56 kHz 2.4 kHz

Table 11. Subwoofer Configuration / Spectrum Analyzer / HighPass (12)

MSB				LSB				FUNCTION
D7	D6	D5	D4	D3	D2	D1	D0	
						0 0 1 1	0 1 0 1	Subwoofer Filter off 80Hz <u>120Hz</u> 160Hz
				0 0 1 1	0 1 0 1			Subwoofer Coupling AC using SW _{In} pin AC using Mix _{InR} pins AC using SW _{In} pin <u>DC</u>
			0 1					Spectrum Analyzer Q-Factor 3.5 <u>1.8</u>
		0 1						High Pass Enable Filter off <u>Filter on</u>
0 0 1 1	0 1 0 1							High Pass Cut-Off-Frequency 90Hz 135Hz 180Hz <u>215Hz</u>

Table 12. Configuration Audioprocessor I (13)

MSB				LSB				FUNCTION
D7	D6	D5	D4	D3	D2	D1	D0	
							0 1	CDC Input Mode single ended pseudo differential
						0 1		CDC Input Gain -6 dB <u>0 dB</u>
					0 1			SoftStep Volume off <u>on</u>
			0 0 1 1	0 1 0 1				SoftStep Time 320µs 1.28ms 5.12ms <u>20.4ms</u>
		0 1						Loudness flat <u>filter ON</u>
	0 1							Mixing Selector Tuner/TIM Switch TIM <u>Tuner</u>
0 1								Tuner Selection AM <u>Stereodecoder</u>

Table 13. Configuration Audioprocessor II (14)

MSB							LSB	FUNCTION
D7	D6	D5	D4	D3	D2	D1	D0	
							0 1	Pause Detector off on
					0 0 1 1	0 1 0 1		Pause ZC Window 160mV 80mV 40mV not allowed
			0 0 1 1	0 1 0 1				Front Speaker Mixing AC _{In} and Mix _{In} AC coupling (Mix _{In}) AC coupling (AC _{In}) DC coupling
	0 0 1 1	0 1 0 1						Rear Speaker Mixing AC _{In} and Mix _{In} AC coupling (Mix _{In}) AC coupling (AC _{In}) DC coupling
1								must be "1"

Table 14. Speaker and Subwoofer Level Control (15,16,17,18,19)

MSB							LSB	ATTENUATION
D7	D6	D5	D4	D3	D2	D1	D0	
	0 : 0 0 0 0 : 0 : 0 : 1 : 1 : 1 : 1	0 : 0 0 0 0 : 1 : 0 : 0 : 0 : 1	0 : 0 1 1 : 0 : 0 : 1 : 1 : X	1 : 0 0 0 0 : 0 : 0 : 0 : 1 : 1 : X	1 : 0 0 0 0 : 0 : 0 : 0 : 1 : 1 : X	1 : 0 0 0 0 : 0 : 0 : 0 : 1 : 1 : X	1 : 1 : 0 : 1 : 0 : 1 : 1 : X	Gain/Attenuation +15dB : + 1dB 0dB 0dB - 1dB : -16dB : -32dB : -48dB : -64dB : -79dB Mute
0 1								SoftStep On/Off On Off

Table 15. Mixer Level Control (20)

MSB							LSB	ATTENUATION
D7	D6	D5	D4	D3	D2	D1	D0	
1	0	0	0	1	1	1	1	Gain/Attenuation +15dB
:	:	:	:	:	:	:	:	:
1	0	0	0	0	0	0	1	+ 1dB
1	0	0	0	0	0	0	0	0dB
0	0	0	0	0	0	0	0	0dB
0	0	0	0	0	0	0	1	- 1dB
:	:	:	:	:	:	:	:	:
0	0	0	0	1	1	1	1	-15dB
0	0	0	1	0	0	0	0	-16dB
:	:	:	:	:	:	:	:	:
0	1	0	0	1	1	1	0	-78dB
0	1	0	0	1	1	1	1	-79dB
X	1	1	X	X	X	X	X	<u>Mute</u>

Table 16. Testing Audioprocessor (21)

MSB							LSB	FUNCTION
D7	D6	D5	D4	D3	D2	D1	D0	
							0 1	Audioprocessor Testmode <u>off</u> on
			0 1 0 1 0 1 X 0 1 X X X	0 0 0 0 0 1 0 1 0 1 1	0 0 0 1 1 0 1 0 0 0 1 1	0 0 1 1 0 0 0 0 0 1 0 1		Test-Multiplexer Spectrum Analyzer Filter 62Hz Spectrum Analyzer Filter 157Hz Spectrum Analyzer Filter 400Hz Spectrum Analyzer Filter 1kHz Spectrum Analyzer Filter 2.51kHz Spectrum Analyzer Filter 6.34kHz Spectrum Analyzer Filter 16kHz Not Allowed not used 200kHz Oscillator NB-Hold <u>internal Reference</u>
		0 1						Clock external <u>internal</u>
	0 1							AZ Function off <u>on</u>
0 1								SC-Clock Fast Mode <u>Normal Mode</u>

Note: This byte is used for testing or evaluation purposes only and must not set to other values than "1111110" in the application!

Table 17. Stereodecoder (22)

MSB							LSB	FUNCTION
D7	D6	D5	D4	D3	D2	D1	D0	
							0 1	<u>STD Unmuted</u> <u>STD Muted</u>
					0 0 1 1	0 1 0 1		<u>IN-Gain 11dB</u> <u>IN-Gain 8.5dB</u> <u>IN-Gain 6dB</u> <u>IN-Gain 3.5dB</u>
				0 1				<u>Stereodecoder Input</u> <u>AM</u> <u>MPX</u>
			0 1					<u>Forced MONO</u> <u>MONO/STEREO switch automatically</u>
		0 1						<u>Pilot Threshold HIGH</u> <u>Pilot Threshold LOW</u>
0 0 1 1	0 1 0 1							<u>De-emphasis 50µs (37.5µs¹)</u> <u>De-emphasis 62.5µs (46.9µs¹)</u> <u>De-emphasis 75µs (56.3µs¹)</u> <u>De-emphasis 100µs (75µs¹)</u>

¹If De-emphasis-Shift enabled (Subaddr.26/Bit7 = 0)

Table 18. Noiseblanker I (23)

MSB							LSB	FUNCTION
D7	D6	D5	D4	D3	D2	D1	D0	
							0 1	<u>Noiseblanker off</u> <u>Noiseblanker on</u>
				0 0 0 0 1 1 1 1	0 0 1 1 0 1 1 1	0 1 0 1 0 1 0 1		<u>Low Threshold 65mV</u> <u>Low Threshold 60mV</u> <u>Low Threshold 55mV</u> <u>Low Threshold 50mV</u> <u>Low Threshold 45mV</u> <u>Low Threshold 40mV</u> <u>Low Threshold 35mV</u> <u>Low Threshold 30mV</u>
		0 0 1 1	0 1 0 1					<u>Noise Controlled Threshold 320mV</u> <u>Noise Controlled Threshold 260mV</u> <u>Noise Controlled Threshold 200mV</u> <u>Noise Controlled Threshold 140mV</u>
0 0 1 1	0 1 0 1							<u>Over deviation Adjust 2.8V</u> <u>Over deviation Adjust 2.0V</u> <u>Over deviation Adjust 1.2V</u> <u>Over deviation Detector OFF</u>

Table 19. Noiseblanker II (24)

MSB							LSB	FUNCTION
D7	D6	D5	D4	D3	D2	D1	D0	
							0 1	PEAK charge current low high
					0 0 1 1	0 1 0 1		Fieldstrength adjust 2.3V 1.8V 1.3V OFF
			0 0 1 1	0 1 0 1				Blank Time FM / AM 38µs / 1.2ms 25.5µs / 800µs 32µs / 1.0s <u>22µs / 640µs</u>
	0 0 1 1	0 1 0 1						Noise Rectifier Discharge Resistor R = infinite R _{DC} = 56k R _{DC} = 33k <u>R_{DC} = 18k</u>
0 1								Strong Multipath influence on PEAK 18k off <u>on (18k discharge if V_{MPout} ≤ 2.5V)</u>

Table 20. AM / FM-Noiseblanker (25)

MSB							LSB	FUNCTION
D7	D6	D5	D4	D3	D2	D1	D0	
							0 1	Stereodecoder Mode FM AM
				0 0 0 0 1 1 1 1	0 0 1 1 0 0 1 1	0 1 0 1 0 1 0 1		AM Rectifier Gain 6dB 8dB 10dB 12dB 14dB 16dB 18dB <u>20dB</u>
		0 0 1 1	0 1 0 1					Rectifier Cut-Off Frequency 14.0kHz 18.5kHz 28.0kHz <u>56.0kHz</u>
1	1							must be "1"

Table 21. High-Cut (26)

MSB							LSB	FUNCTION
D7	D6	D5	D4	D3	D2	D1	D0	
							0 1	High-Cut <u>off</u> on
					0 0 1 1	0 1 0 1		max. High-Cut 2dB 5dB 7dB <u>10dB</u>
			0 0 1 1	0 1 0 1				VHCH to be at 42% REF5V 50% REF5V 58% REF5V <u>66% REF5V</u>
	0 0 1 1	0 1 0 1						VHCL to be at 16.7% VHCH 22.2% VHCH 27.8% VHCH <u>33.3% VHCH</u>
0 1								De-emphasis Shift On <u>Off</u>

Table 22. Fieldstrength Control (27)

MSB							LSB	FUNCTION	
D7	D6	D5	D4	D3	D2	D1	D0		
				0 0 0 0 0 0 0 0 1 1 1 1 1 1 1	0 0 0 0 1 1 1 1 0 0 0 1 1 1 1	0 0 1 1 0 0 0 1 0 0 1 0 0 1 0	0 1 0 1 0 0 1 1 0 1 0 0 1 0 1	VSBL to be at 20.0% REF5V 23.3% REF5V 26.6% REF5V 30.0% REF5V 33.3% REF5V 36.6% REF5V 40.0% REF5V 43.3% REF5V 46.6% REF5V 50.0% REF5V 53.3% REF5V 56.6% REF5V 60.0% REF5V 63.3% REF5V <u>66.6% REF5V</u> 70.0% REF5V	
		0 0 1 1	0 1 0 1						Quality Detector Coefficient a=0.7 a=0.85 a=1.0 <u>a=1.15</u>
0 0 1 1	0 1 0 1								HCC-Level-Shift (only Level through MPD) 0.0V 500mV 1.0 V <u>1.5 V</u>

Table 23. Multipath Detector (28)

MSB							LSB	FUNCTION
D7	D6	D5	D4	D3	D2	D1	D0	
							0 1	Fast Load on off
					0 0 1 1	0 1 0 1		Bandpass Gain 6dB 12dB 16dB 18dB
			0 0 1 1	0 1 0 1				Rectifier Gain Gain = 7.6dB Gain = 4.6dB Gain = 0dB disabled
		0 1						Charge Current at MP-Out 0.25µA 0.50µA
	0 1							Multipath on High-Cut Decay-Time 2ms 10ms
0 1								Multipath influence on PEAK Discharge off -1V/ms

Table 24. Stereodecoder Adjustment (29)

MSB							LSB	FUNCTION
D7	D6	D5	D4	D3	D2	D1	D0	
0 0 0 : 0 : 0					0 0 0 : 1 : 1	0 0 1 : 0 : 1	0 1 0 : 0 : 1	Roll-Off Compensation not allowed 7.2% 9.4% : 13.7% : 20.2%
1 1 1 : 1 : 1					0 0 0 : 1 : 1	0 0 1 : 0 : 1	0 1 0 : 0 : 1	not allowed 19.6% 21.5% : 25.3% : 31.0%
	0 0 0 : 1	0 0 0 : 1	0 0 1 : 1	0 1 0 : 1				LEVEL Gain 0dB 0.4dB 0.8dB : 6dB

Table 25. Stereodecoder Configuration (30)

MSB							LSB	FUNCTION
D7	D6	D5	D4	D3	D2	D1	D0	
							0 1	Multipath Influence on High-Cut On Off
						0 1		Multipath Influence on Stereo-Blend On Off
					0 1	1 x	1 x	Level-Input over Multipath-Detector¹ On Off
					0 1			Dual MPX Mode On Off
1	1	1	1					must be "1"

¹ Using the Multipath Time-Constants for Stereo-Bland and High-Cut

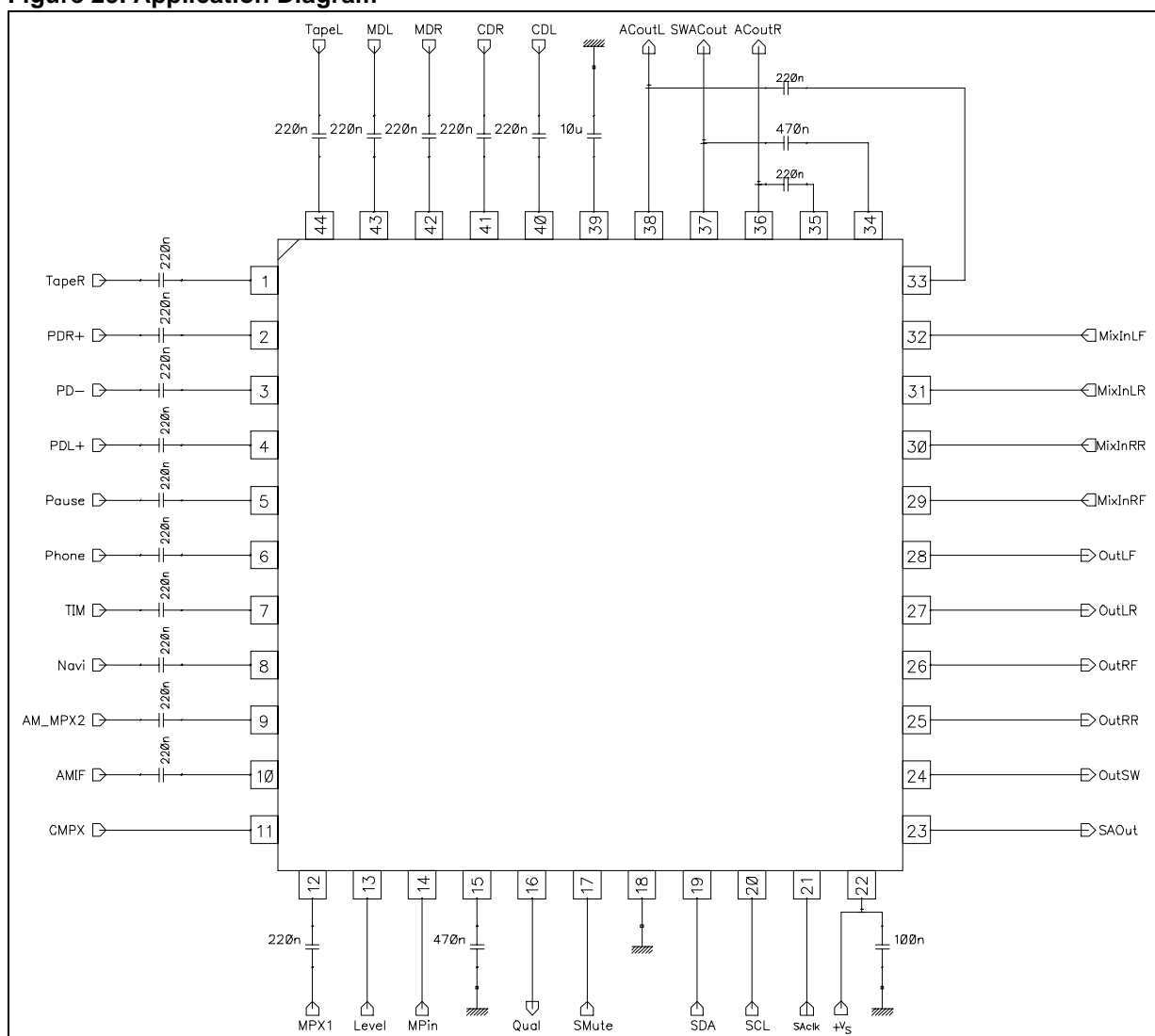
Table 26. Testing Stereodecoder(31)

MSB							LSB	FUNCTION
D7	D6	D5	D4	D3	D2	D1	D0	
							0 1	Main Testmode off on
						0 1		Stereodecoder Testmode off on
		0 0 0 0 0 0 0 0 1 1 1 1 1 1 1	0 0 0 0 1 1 1 1 0 0 0 1 1 1 1	0 0 1 1 0 1 1 1 0 0 1 1 1 1 1	0 1 0 1 0 0 0 0 0 0 1 0 1 0 1			Test signals F228 NB threshold Level for Stereo-Blend Pilot magnitude VHCCL Pilot threshold VHCCH REF5V HOLDN NB Peak AM-Rectifier VCOCON; VCO Control Voltage VSBL Pilot threshold Level for High-Cut REF5V
	0 1							Audioprocessor Oscillator Off On
1								must be "1"

Note: This byte is used for testing or evaluation purposes only and must not be set to other values than "1111100" in the application!

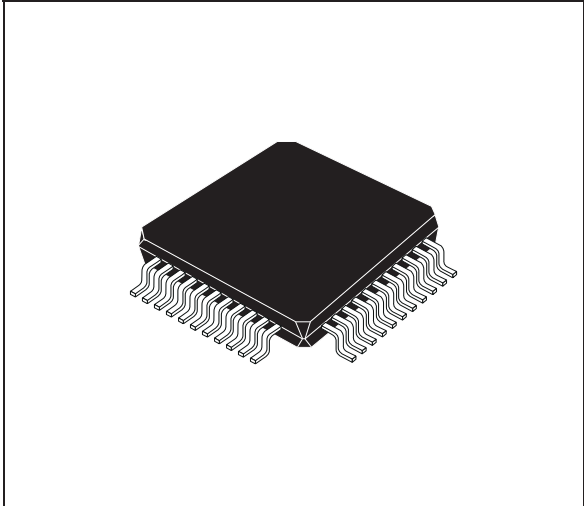


Figure 29. Application Diagram

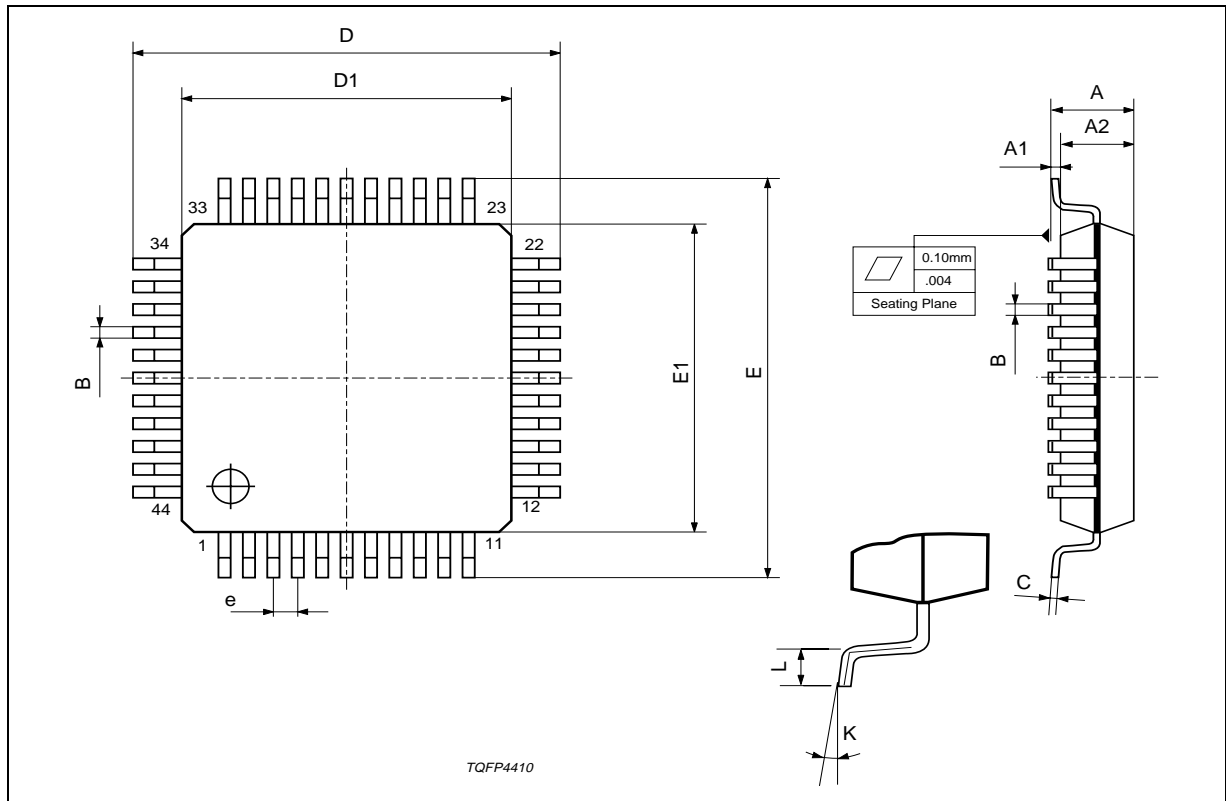


DIM.	mm			inch		
	MIN.	TYP.	MAX.	MIN.	TYP.	MAX.
A			1.60			0.063
A1	0.05		0.15	0.002		0.006
A2	1.35	1.40	1.45	0.053	0.055	0.057
B	0.30	0.37	0.45	0.012	0.014	0.018
C	0.09		0.20	0.004		0.008
D		12.00			0.472	
D1		10.00			0.394	
D3		8.00			0.315	
e		0.80			0.031	
E		12.00			0.472	
E1		10.00			0.394	
E3		8.00			0.315	
L	0.45	0.60	0.75	0.018	0.024	0.030
L1		1.00			0.039	
K	0°(min.), 3.5°(typ.), 7°(max.)					

OUTLINE AND MECHANICAL DATA



TQFP44 (10 x 10)



Information furnished is believed to be accurate and reliable. However, STMicroelectronics assumes no responsibility for the consequences of use of such information nor for any infringement of patents or other rights of third parties which may result from its use. No license is granted by implication or otherwise under any patent or patent rights of STMicroelectronics. Specifications mentioned in this publication are subject to change without notice. This publication supersedes and replaces all information previously supplied. STMicroelectronics products are not authorized for use as critical components in life support devices or systems without express written approval of STMicroelectronics.

The ST logo is a registered trademark of STMicroelectronics
© 2001 STMicroelectronics - All Rights Reserved

STMicroelectronics GROUP OF COMPANIES
Australia - Brazil - China - Finland - France - Germany - Hong Kong - India - Italy - Japan - Malaysia - Malta - Morocco - Singapore - Spain
- Sweden - Switzerland - United Kingdom - U.S.A.
<http://www.st.com>