

Features

- Operating voltage: 2.0V~5.5V
- Serial mode for the HT9200A
- Serial/parallel mode for the HT9200B
- Low standby current
- Low total harmonic distortion
- 3.58MHz crystal or ceramic resonator
- HT9200A: 8-pin DIP/SOP package
- HT9200B: 14-pin SOP package

General Description

The HT9200A/B tone generators are designed for MCU interfaces. They can be instructed by a MCU to generate 16 dual tones and 8 single tones from the DTMF pin. The HT9200A provides a serial mode whereas the

HT9200B contains a selectable serial/parallel mode interface for various applications such as security systems, home automation, remote control through telephone lines, communication systems, etc.

Selection Table

Part No. \ Function	Operating Voltage	OSC Frequency	Interface	Package
HT9200A	2V~5.5V	3.58MHz	Serial	8 DIP/SOP
HT9200B	2V~5.5V	3.58MHz	Serial/Parallel	14 SOP

Block Diagram

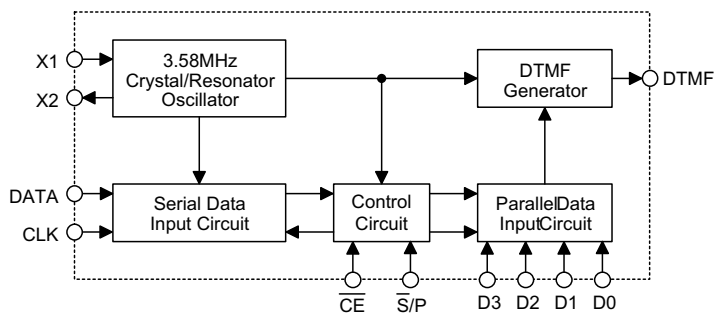

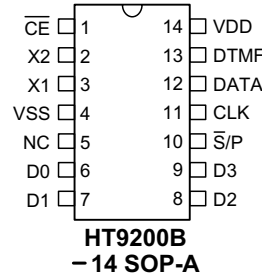
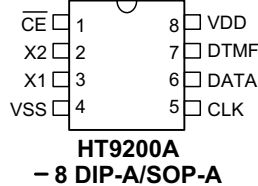
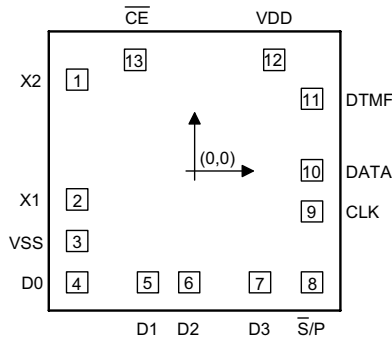
Pin Assignment

Pad Assignment

Pad Coordinates

 Unit: μm

Pad No.	X	Y	Pad No.	X	Y
1	-553.30	430.40	8	553.30	-523.50
2	-553.30	-133.50	9	553.30	-190.30
3	-553.30	-328.50	10	553.30	4.70
4	-553.30	-523.50	11	553.30	340.30
5	-220.10	-523.50	12	374.90	523.50
6	-25.10	-523.50	13	-279.30	523.50
7	308.10	-523.50			

 Chip size: $1460 \times 1470 (\mu\text{m})^2$

* The IC substrate should be connected to VSS in the PCB layout artwork.

Pin Description

Pin Name	I/O	Internal Connection	Description
$\overline{\text{CE}}$	I	CMOS IN Pull-high	Chip enable, active low
X2	O	Oscillator	The system oscillator consists of an inverter, a bias resistor, and the required load capacitor on chip. The oscillator function can be implemented by Connect a standard 3.579545MHz crystal to the X1 and X2 terminals.
X1	I		
VSS	—	—	Negative power suppl, ground
NC	—	—	No connection
D0~D3	I	CMOS IN Pull-high or Floating	Data inputs for the parallel mode When the IC is operating in the serial mode, the data input terminals (D0~D3) are included with a pull-high resistor. When the IC is operating in the parallel mode, these pins become floating.
$\overline{\text{S/P}}$	I	CMOS IN	Operation mode selection input $\overline{\text{S/P}}=\text{"H"}:$ Parallel mode $\overline{\text{S/P}}=\text{"L"}:$ Serial mode
CLK	I	CMOS IN Pull-high or Floating	Data synchronous clock input for the serial mode When the IC is operating in the parallel mode, the input terminal (CLK) is included with a pull-high resistor. When the IC is operating in the serial mode, this pin becomes floating.

Pin Name	I/O	Internal Connection	Description
DATA	I	CMOS IN Pull-high or Floating	Data input terminal for the serial mode When the IC is operating in the parallel mode, the input terminal (DATA) is included with a pull-high resistor. When the IC is operating in the serial mode, this pin becomes floating.
DTMF	O	CMOS OUT	Output terminal of the DTMF signal
VDD	—	—	Positive power supply, 2.0V~5.5V for normal operation

Approximate internal connection circuits

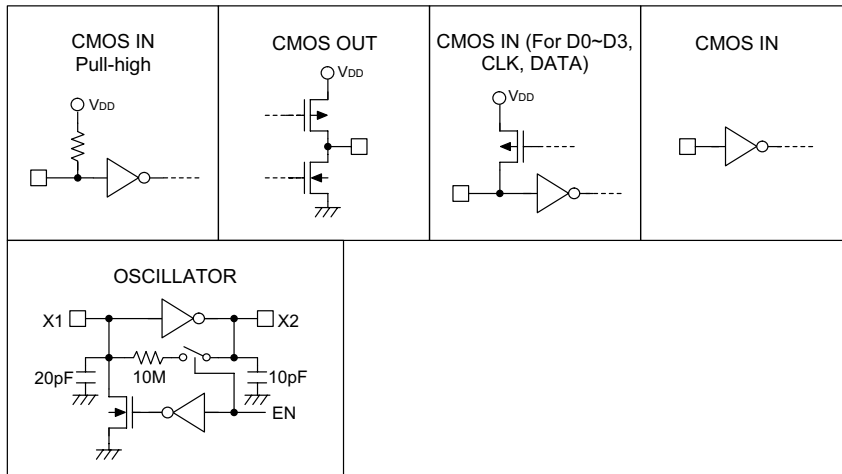

Absolute Maximum Ratings

Supply Voltage	-0.3V to 6V	Storage Temperature	-50°C to 125°C
Input Voltage	$V_{SS}-0.3$ to $V_{DD}+0.3V$	Operating Temperature	-20°C to 75°C

Note: These are stress ratings only. Stresses exceeding the range specified under "Absolute Maximum Ratings" may cause substantial damage to the device. Functional operation of this device at other conditions beyond those listed in the specification is not implied and prolonged exposure to extreme conditions may affect device reliability.

Electrical Characteristics

Ta=25°C

Symbol	Parameter	Test Conditions		Min.	Typ.	Max.	Unit
		V _{DD}	Conditions				
V _{DD}	Operating Voltage	—	—	2	—	5.5	V
I _{DD}	Operating Current	2.5V	$\overline{S}/P=V_{DD}, D0\sim D3=V_{SS},$ $\overline{CE}=V_{SS},$ No load	—	240	2500	μA
		5.0V		—	950	3000	
V _{IL}	"Low" Input Voltage	—	—	V _{SS}	—	0.2V _{DD}	V
V _{IH}	"High" Input Voltage	—	—	0.8V _{DD}	—	V _{DD}	V
I _{STB}	Standby Current	2.5V	$\overline{S}/P=V_{DD}, \overline{CE}=V_{DD},$ no load	—	—	1	μA
		5.0V		—	—	2	
R _P	Pull-high Resistance	2.5V	V _{OL} =0V	120	180	270	kΩ
		5.0V		45	68	100	
t _{DE}	DTMF Output Delay Time (Parallel Mode)	5V	—	—	t _{UP} +6	t _{UP} +8	ms
V _{TDC}	DTMF Output DC Level	2V~5.5V	DTMF Output	0.45V _{DD}	—	0.75V _{DD}	V
I _{TOL}	DTMF Sink Current	2.5V	V _{DTMF} =0.5V	-0.1	—	—	mA
V _{TAC}	DTMF Output AC Level	2.5V	Row group, R _L =5kΩ	0.12	0.15	0.18	V _{rms}
A _{CR}	Column Pre-emphasis	2.5V	Row group=0dB	1	2	3	dB
R _L	DTMF Output Load	2.5V	t _{HD} ≤ -23dB	5	—	—	kΩ
t _{HD}	Tone Signal Distortion	2.5V	R _L =5kΩ	—	-30	-23	dB
f _{CLK}	Clock Input Rate (Serial Mode)	—	—	—	100	500	kHz
t _{UP}	Oscillator Starting Time (When \overline{CE} is low)	5.0V	The time from \overline{CE} falling edge to normal oscillator operation	—	—	10	ms
f _{OSC}	System Frequency	—	Crystal=3.5795MHz	3.5759	3.5795	3.5831	MHz

Functional Description

The HT9200A/B are DTMF generators for MCU interfaces. They are controlled by a MCU in the serial mode or the parallel mode (for the HT9200B only).

Serial mode (HT9200A/B)

The HT9200A/B employ a data input, a 5-bit code, and a synchronous clock to transmit a DTMF signal. Every digit of a phone number to be transmitted is selected by a series of inputs which consist of 5-bit data. Of the 5

bits, the D0(LSB) is the first received bit. The HT9200A/B will latch data on the falling edge of the clock (CLK pin). The relationship between the digital codes and the tone output frequency is shown in Table 1. As for the control timing diagram, refer to Figure 1.

When the system is operating in the serial mode a pull-high resistor is attached to D0~D3 (for parallel mode) on the input terminal.

Table 1: Digits vs. input data vs. tone output frequency (serial mode)

Digit	D4	D3	D2	D1	D0	Tone Output Frequency (Hz)
1	0	0	0	0	1	697+1209
2	0	0	0	1	0	697+1336
3	0	0	0	1	1	697+1477
4	0	0	1	0	0	770+1209
5	0	0	1	0	1	770+1336
6	0	0	1	1	0	770+1477
7	0	0	1	1	1	852+1209
8	0	1	0	0	0	852+1336
9	0	1	0	0	1	852+1477
0	0	1	0	1	0	941+1336
*	0	1	0	1	1	941+1209
#	0	1	1	0	0	941+1477
A	0	1	1	0	1	697+1633
B	0	1	1	1	0	770+1633
C	0	1	1	1	1	852+1633
D	0	0	0	0	0	941+1633
—	1	0	0	0	0	697
—	1	0	0	0	1	770
—	1	0	0	1	0	852
—	1	0	0	1	1	941
—	1	0	1	0	0	1209
—	1	0	1	0	1	1336
—	1	0	1	1	0	1477
—	1	0	1	1	1	1633
DTMF OFF	1	1	1	1	1	—

Note: The codes not listed in Table 1 are not used D4 is MSB

For the HT9200B, the $\overline{S/P}$ pin has to be connected low for serial mode operation.

Parallel mode (HT9200B)

The HT9200B provides four data inputs D0~D3 to generate their corresponding DTMF signals. The $\overline{S/P}$ has to be connected high to select the parallel operation mode. Then the input data codes should be determined. Finally, the \overline{CE} is connected low to transmit the DTMF signal from the DTMF pin.

The T_{DE} time (about 6ms) will be delayed from the \overline{CE} falling edge to the DTMF signal output.

The relationship between the digital codes and the tone output frequency is illustrated in Table 2. As for the control timing diagram, see Figure 2.

When the system is operating in the parallel mode, D0~D3 are all in the floating state. Thus, these data input pins should not float.

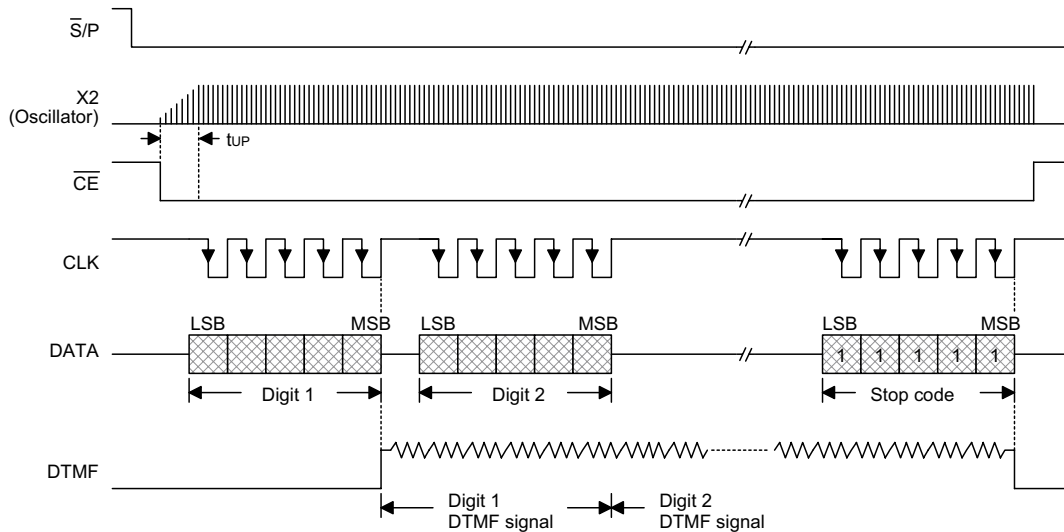
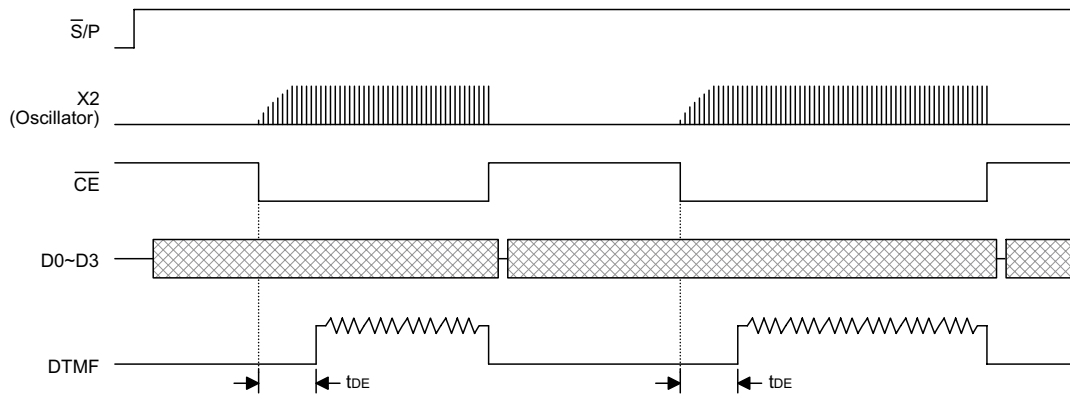

Figure 1

Table 2: Digits vs. input data vs. tone output frequency (parallel mode)

Digit	D3	D2	D1	D0	Tone Output Frequency (Hz)
1	0	0	0	1	697+1209
2	0	0	1	0	697+1336
3	0	0	1	1	697+1477
4	0	1	0	0	770+1209
5	0	1	0	1	770+1336
6	0	1	1	0	770+1477
7	0	1	1	1	852+1209
8	1	0	0	0	852+1336
9	1	0	0	1	852+1477
0	1	0	1	0	941+1336
*	1	0	1	1	941+1209
#	1	1	0	0	941+1477
A	1	1	0	1	697+1633
B	1	1	1	0	770+1633
C	1	1	1	1	852+1633
D	0	0	0	0	941+1633



Note: The data (D0~D3) should be ready before the \overline{CE} becomes low.

Figure 2

Tone frequency

Output Frequency (Hz)		%Error
Specified	Actual	
697	699	+0.29%
770	766	0.52%
852	847	0.59%
941	948	+0.74%
1209	1215	+0.50%
1336	1332	0.30%
1477	1472	0.34%

% Error does not contain the crystal frequency drift

Application Circuits

Serial mode

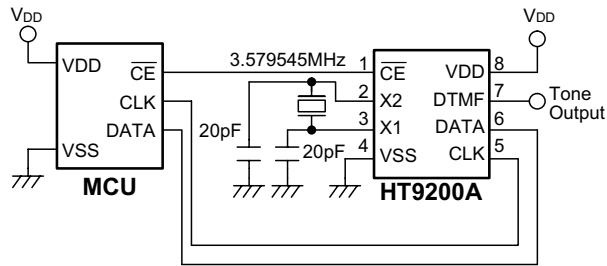

Serial/parallel mode

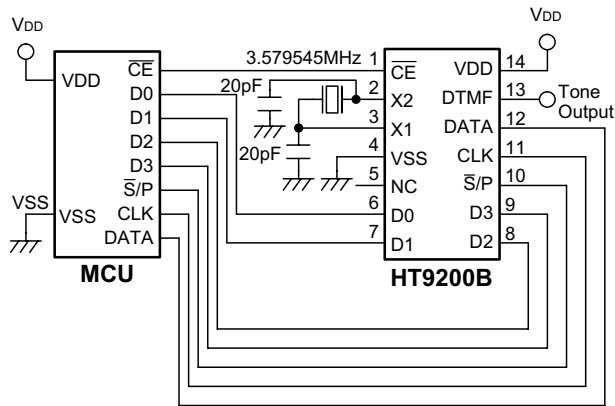

Package Information

8-pin DIP (300mil) outline dimensions

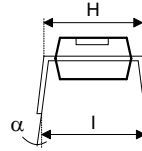
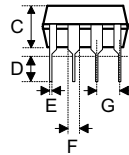
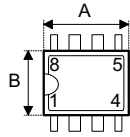

Symbol	Dimensions in mil		
	Min.	Nom.	Max.
A	355	—	375
B	240	—	260
C	125	—	135
D	125	—	145
E	16	—	20
F	50	—	70
G	—	100	—
H	295	—	315
I	335	—	375
α	0°	—	15°

8-pin SOP (150mil) outline dimensions

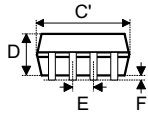
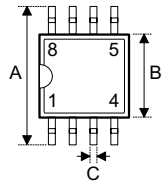

Symbol	Dimensions in mil		
	Min.	Nom.	Max.
A	228	—	244
B	149	—	157
C	14	—	20
C'	189	—	197
D	53	—	69
E	—	50	—
F	4	—	10
G	22	—	28
H	4	—	12
α	0°	—	10°

14-pin SOP (150mil) outline dimensions

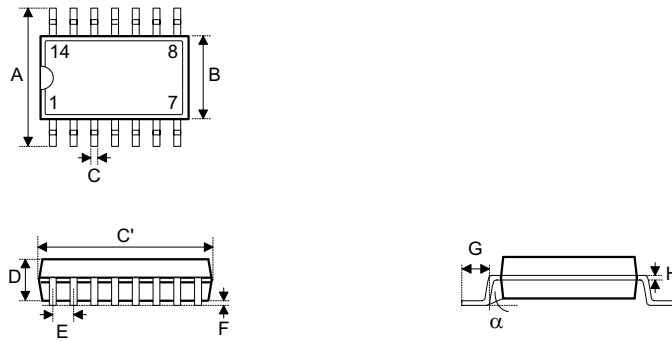

Symbol	Dimensions in mil		
	Min.	Nom.	Max.
A	228	—	244
B	149	—	157
C	14	—	20
C'	336	—	344
D	53	—	69
E	—	50	—
F	4	—	10
G	22	—	28
H	4	—	12
α	0°	—	10°

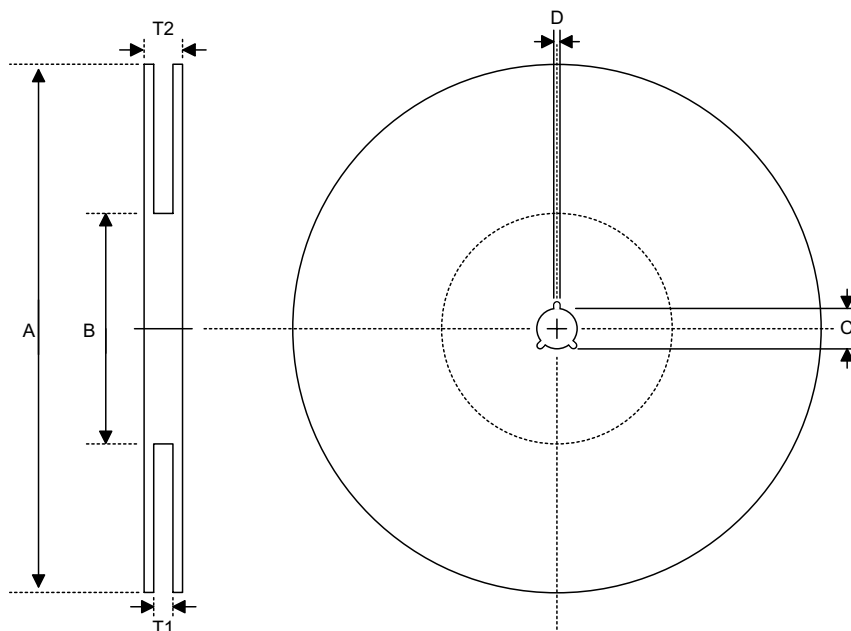
Product Tape and Reel Specifications
Reel dimensions

SOP 8N

Symbol	Description	Dimensions in mm
A	Reel Outer Diameter	330±1.0
B	Reel Inner Diameter	62±1.5
C	Spindle Hole Diameter	13.0+0.5 -0.2
D	Key Slit Width	2.0±0.15
T1	Space Between Flange	12.8+0.3 -0.2
T2	Reel Thickness	18.2±0.2

SOP 14N

Symbol	Description	Dimensions in mm
A	Reel Outer Diameter	330±1.0
B	Reel Inner Diameter	62±1.5
C	Spindle Hole Diameter	13.0+0.5 -0.2
D	Key Slit Width	2.0±0.5
T1	Space Between Flange	16.8+0.3 -0.2
T2	Reel Thickness	22.2±0.2

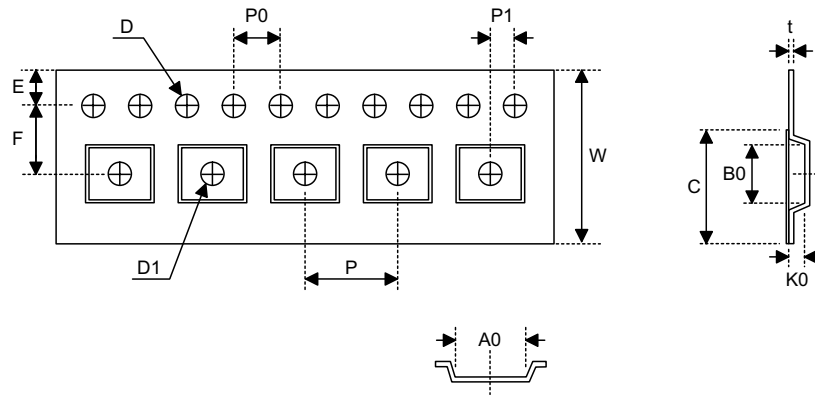
Carrier tape dimensions



SOP 8N

Symbol	Description	Dimensions in mm
W	Carrier Tape Width	12.0+0.3 -0.1
P	Cavity Pitch	8.0±0.1
E	Perforation Position	1.75±0.1
F	Cavity to Perforation (Width Direction)	5.5±0.1
D	Perforation Diameter	1.55±0.1
D1	Cavity Hole Diameter	1.5+0.25
P0	Perforation Pitch	4.0±0.1
P1	Cavity to Perforation (Length Direction)	2.0±0.1
A0	Cavity Length	6.4±0.1
B0	Cavity Width	5.20±0.1
K0	Cavity Depth	2.1±0.1
t	Carrier Tape Thickness	0.3±0.05
C	Cover Tape Width	9.3

SOP 14N

Symbol	Description	Dimensions in mm
W	Carrier Tape Width	16.0+0.3 -0.1
P	Cavity Pitch	8.0±0.1
E	Perforation Position	1.75±0.1
F	Cavity to Perforation (Width Direction)	7.5±0.1
D	Perforation Diameter	1.5+0.1
D1	Cavity Hole Diameter	1.5+0.25
P0	Perforation Pitch	4.0±0.1
P1	Cavity to Perforation (Length Direction)	2.0±0.1
A0	Cavity Length	6.5±0.1
B0	Cavity Width	9.5±0.1
K0	Cavity Depth	2.1±0.1
t	Carrier Tape Thickness	0.3±0.05
C	Cover Tape Width	13.3

Holtek Semiconductor Inc. (Headquarters)

No.3, Creation Rd. II, Science-based Industrial Park, Hsinchu, Taiwan
Tel: 886-3-563-1999
Fax: 886-3-563-1189
<http://www.holtek.com.tw>

Holtek Semiconductor Inc. (Sales Office)

11F, No.576, Sec.7 Chung Hsiao E. Rd., Taipei, Taiwan
Tel: 886-2-2782-9635
Fax: 886-2-2782-9636
Fax: 886-2-2782-7128 (International sales hotline)

Holtek Semiconductor (Shanghai) Inc.

7th Floor, Building 2, No.889, Yi Shan Rd., Shanghai, China
Tel: 021-6485-5560
Fax: 021-6485-0313
<http://www.holtek.com.cn>

Holtek Semiconductor (Hong Kong) Ltd.

RM.711, Tower 2, Cheung Sha Wan Plaza, 833 Cheung Sha Wan Rd., Kowloon, Hong Kong
Tel: 852-2-745-8288
Fax: 852-2-742-8657

Holmate Semiconductor, Inc.

46712 Fremont Blvd., Fremont, CA 94538
Tel: 510-252-9880
Fax: 510-252-9885
<http://www.holmate.com>

Copyright © 2002 by HOLTEK SEMICONDUCTOR INC.

The information appearing in this Data Sheet is believed to be accurate at the time of publication. However, Holtek assumes no responsibility arising from the use of the specifications described. The applications mentioned herein are used solely for the purpose of illustration and Holtek makes no warranty or representation that such applications will be suitable without further modification, nor recommends the use of its products for application that may present a risk to human life due to malfunction or otherwise. Holtek's products are not authorized for use as critical components in life support devices or systems. Holtek reserves the right to alter its products without prior notification. For the most up-to-date information, please visit our web site at <http://www.holtek.com.tw>.