

Features

- Precision reference voltage
- AP432 : 1.24V ± 1%
- AP432A : 1.24V ± 0.5%
- Sink current capability: 200mA
- Minimum cathode current for regulation: 150µA
- Equivalent full-range temp coefficient: 30 ppm/°C
- Fast turn-on Response.
- Low dynamic output impedance: 0.2Ω
- Programmable output voltage to 20V
- Low output noise
- Packages: SOT89-3L, TO92-3L, SOP-8L, SOT23, SOT25, SC-59

General Description

The AP432/432A are 3-terminal adjustable precision shunt regulators with guaranteed stable temperature over the applicable extended commercial temperature range. The output voltage may be set at any level greater than 1.24V (V_{REF}) up to 20V merely by selecting two external resistors that act as a voltage divider network. These devices have a typical output impedance of 0.2Ω. Active output circuitry provides very sharp turn-on characteristics, making these devices excellent improved replacements for Zener diodes in many applications.

The precise +/- 1% reference voltage tolerance of the AP432/432A make it possible in many applications to avoid the use of a variable resistor, consequently saving cost and eliminating drift and reliability problems associated with it

Ordering Information

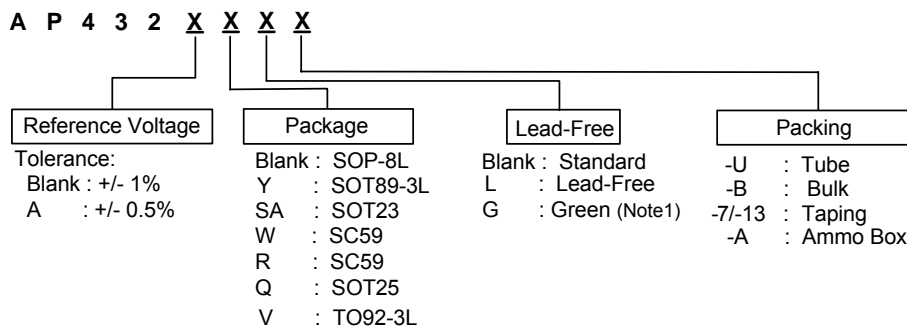

Note: 1. Only for SOT23

Device (Note 2)	Package Code	Packaging (Note 3)	7" Tape and Reel		13" Tape and Reel		Ammo Box	
			Quantity	Part Number Suffix	Quantity	Part Number Suffix	Quantity	Part Number Suffix
AP432(A)SA	SA	SOT23	3000/Tape & Reel	-7	10000/Tape & Reel	-13	NA	NA
AP432(A)Q	Q	SOT25	3000/Tape & Reel	-7	10000/Tape & Reel	-13	NA	NA
AP432(A)W	W	SC59	3000/Tape & Reel	-7	10000/Tape & Reel	-13	NA	NA
AP432(A)R	R	SC59	3000/Tape & Reel	-7	10000/Tape & Reel	-13	NA	NA
AP432(A)		SOP-8L	NA	NA	2500/Tape & Reel	-13	NA	NA
AP432(A)Y	Y	SOT89-3L	NA	NA	2500/Tape & Reel	-13	NA	NA
AP432(A)V	V	TO92-3L	NA	NA	NA	NA	2000/Box	-A

Notes: 2. Suffix "A" denotes AP432A device.

3. Pad layout as shown on Diodes Inc. suggested pad layout document AP02001, which can be found on our website at <http://www.diodes.com/datasheets/ap02001.pdf>.

Typical Application Circuit

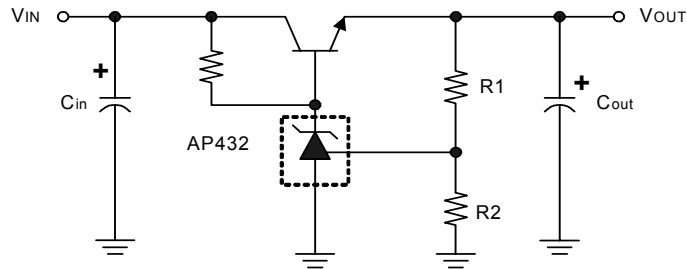

$V_{OUT} = (1 + R1/R2)V_{REF}$
Precision Regulator

Block Diagram

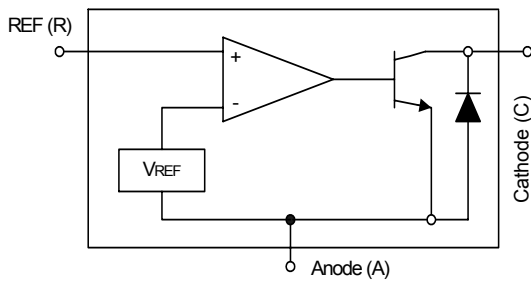

Symbol

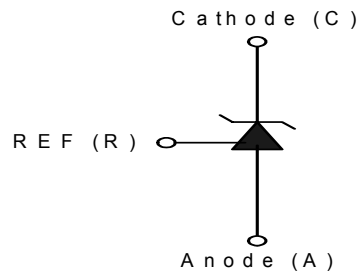

Pin Connections

Package	Pin Configuration (Top View)	Package	Pin Configuration (Top View)
SOT25		SOP-8L	
SC-59 (Package Code-W)		SOT23	
SC-59 (Package Code-R)		SOT89-3L	
TO92-3L			

Absolute Maximum Ratings

Cathode Voltage.....	20V
Continuous cathode current	-10mA ~ 250mA
Reference input current range	10mA
Operating temperature range.....	-20°C ~ 85°C
Lead Temperature.....	260°C
Storage Temperature	-65°C ~ 150°C
Power Dissipation (Notes 4, 5)	
SOT23 Package.....	250mW
SOT25 Package	250mW
SC59 Package.....	400mW
SOP-8L Package	600mW
SOT89-3L Package	800mW
TO92-3L Package.....	780mW

Note: 4. T_J, max =150°C.

Note :5. Ratings apply to ambient temperature at 25°C.

Electrical Characteristics ($T_A = 25^\circ\text{C}$, $V^+ = +5.0\text{V}$, unless otherwise stated)

Parameter	Test conditions	Symbol	Min.	Typ.	Max.	Unit
Reference Voltage	$V_{KA} = V_{ref}$, $I_{KA} = 10\text{mA}$ (Fig.1)	AP432 AP432A	V_{REF} 1.227 1.233	1.24	1.252 1.246	V
Deviation of Reference Input Voltage over Temperature (Note 6)	$V_{KA} = V_{REF}$, $I_{KA} = 10\text{mA}$, $T_a = \text{full range}$ (Fig.1)	V_{REF}		3.0	20	mV
Ratio of the Change in Reference Voltage to the Change in Cathode Voltage	$I_{KA} = 10\text{mA}$ (Fig.2) $V_{KA} = 20 \sim V_{REF}$	$\frac{\Delta V_{REF}}{\Delta V_{KA}}$		-1.4	-2.0	mV/V
Reference Input Current	$R1 = 10\text{K}\Omega, R2 = \infty$ $I_{KA} = 10\text{mA}$ (Fig.2)	I_{REF}		1.4	3.5	μA
Deviation of Reference Input Current over Temperature	$R1 = 10\text{K}\Omega, R2 = \infty$ $I_{KA} = 10\text{mA}$ $T_a = \text{Full range}$ (Fig.2)	αI_{REF}		0.4	1.2	μA
Minimum Cathode Current for Regulation	$V_{KA} = V_{REF}$ (Fig.1)	$I_{KA(\text{min})}$		0.15	0.3	mA
Off-state Current	$V_{KA} = 20\text{V}$, $V_{REF} = 0\text{V}$ (Fig.3)	$I_{KA(\text{off})}$		0.1	1.0	μA
Dynamic Output Impedance (Note 7)	$V_{KA} = V_{REF}$ Frequency $\leq 1\text{KHz}$ (Fig.1)	$ Z_{KA} $		0.2	0.5	Ω

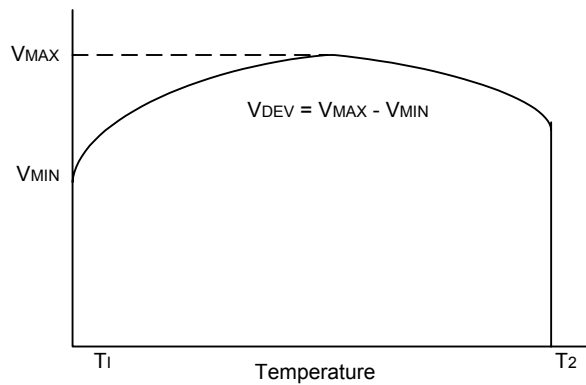

Note 6. Deviation of reference input voltage, V_{DEV} , is defined as the maximum variation of the reference over the full temperature range. The average temperature coefficient of the reference input voltage αV_{REF} is defined as:

$$|\alpha V_{REF}| = \frac{\left(\frac{V_{DEV}}{V_{REF}(25^\circ\text{C})}\right) \cdot 10^6}{T_2 - T_1} \dots\dots\dots (\text{ppm}/^\circ\text{C})$$

Where:

$T_2 - T_1$ = full temperature change.

αV_{REF} can be positive or negative depending on whether the slope is positive or negative.

Note 7. The dynamic output impedance, R_z , is defined as:

$$|Z_{KA}| = \frac{\Delta V_{KA}}{\Delta I_{KA}}$$

When the device is programmed with two external resistors R1 and R2 (see Figure 2.), the dynamic output impedance of the overall circuit, is defined as:

$$|Z_{KA}'| = \frac{\Delta v}{\Delta i} \approx |Z_{KA}| \left(1 + \frac{R1}{R2}\right)$$

Test Circuits

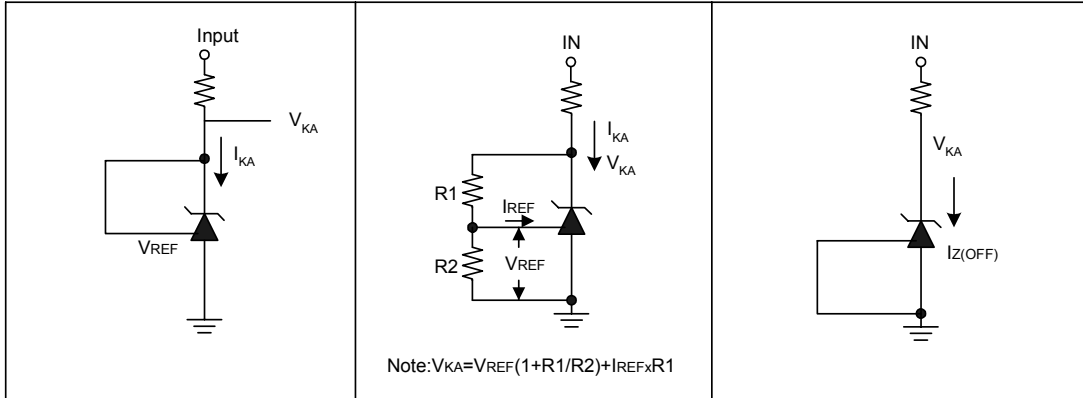

Typical Performance Characteristics

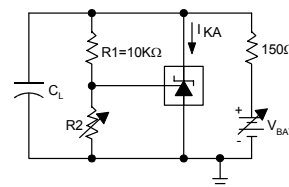
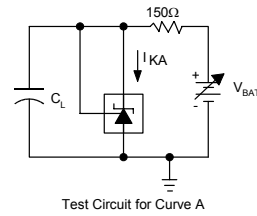
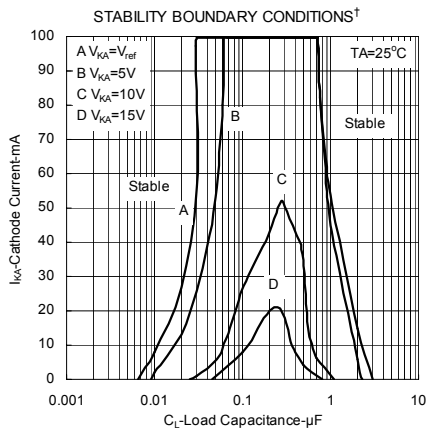
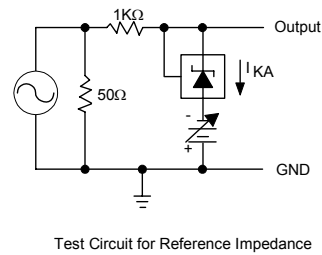
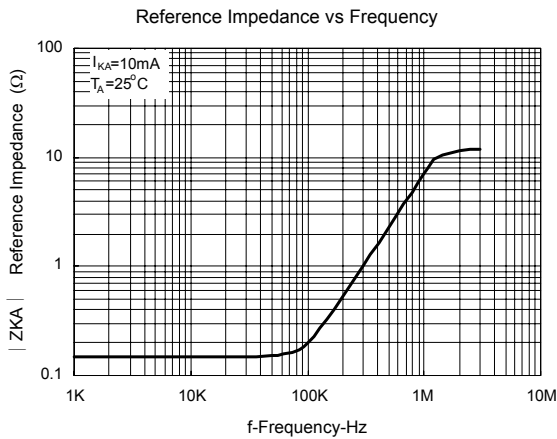
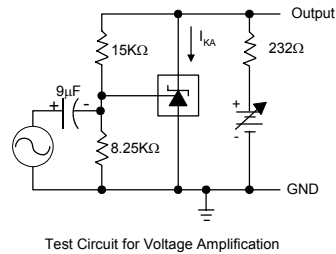
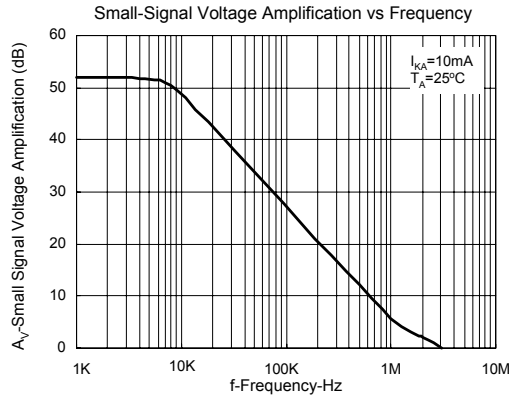

† The areas under the curves represent conditions that may cause the device to oscillate. For curves B, C, and D, R2 and V+ were adjusted to establish the initial V_{KA} and I_{KA} conditions with C_L=0. V_{BATT} and C_L were then adjusted to determine the ranges of stability.

Application Examples

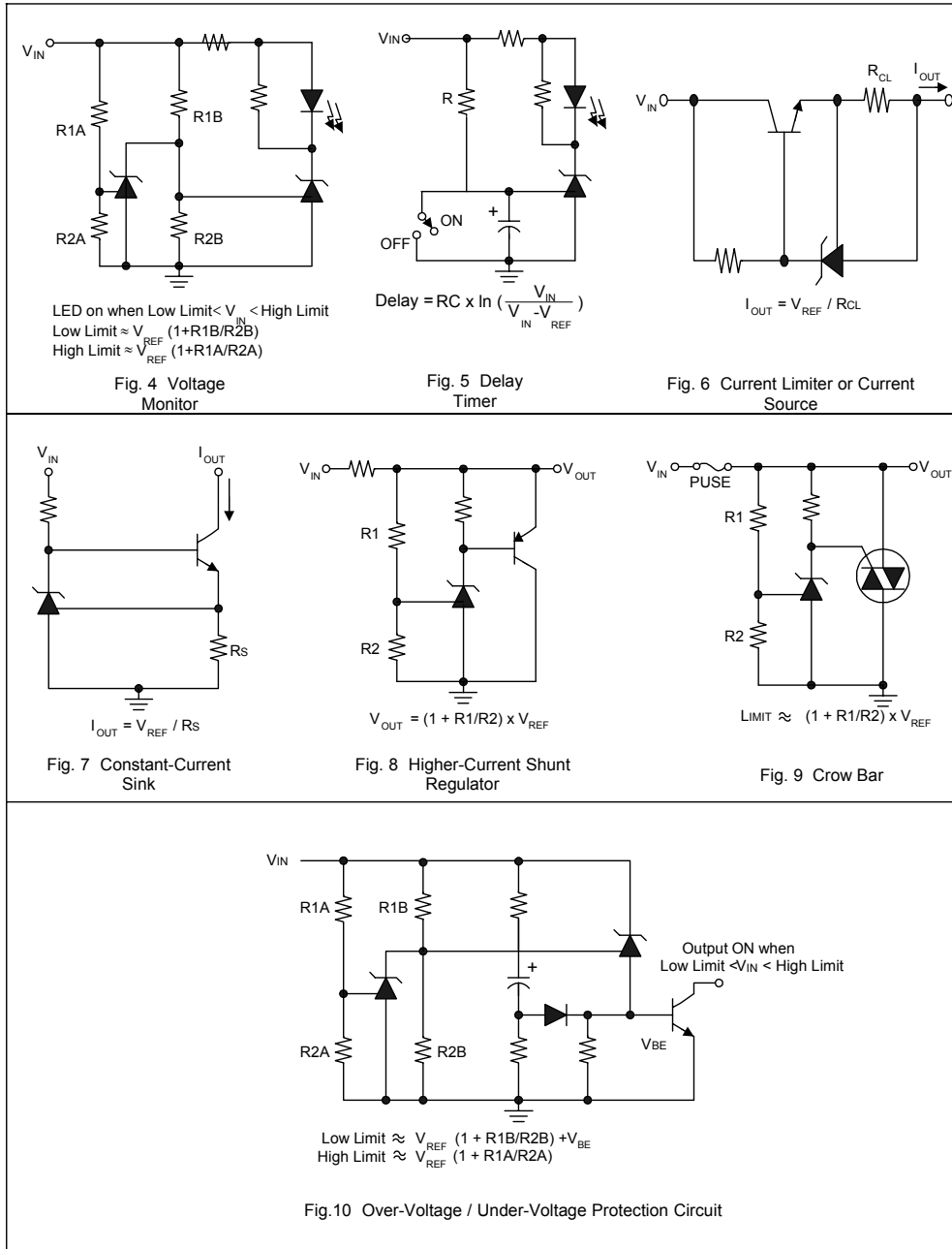

Package Diagrams (All Dimensions in mm)

(1) SOT25

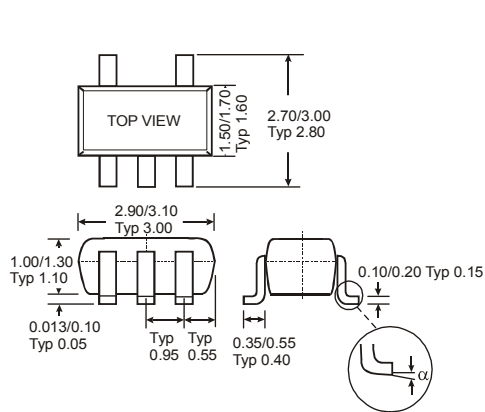

(2) SC59

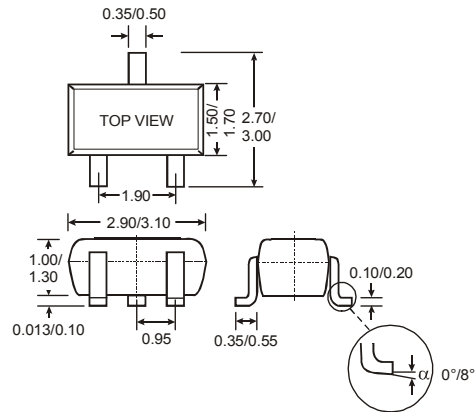

(3) SOT23

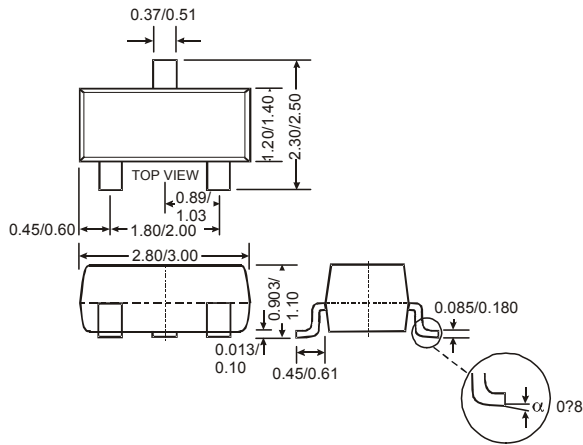

(4) SOP-8L

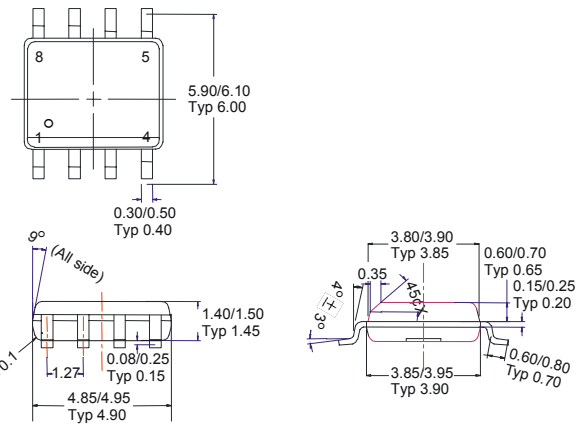

Package Diagrams (Continued) (All Dimensions in mm)

(5) SOT89-3L

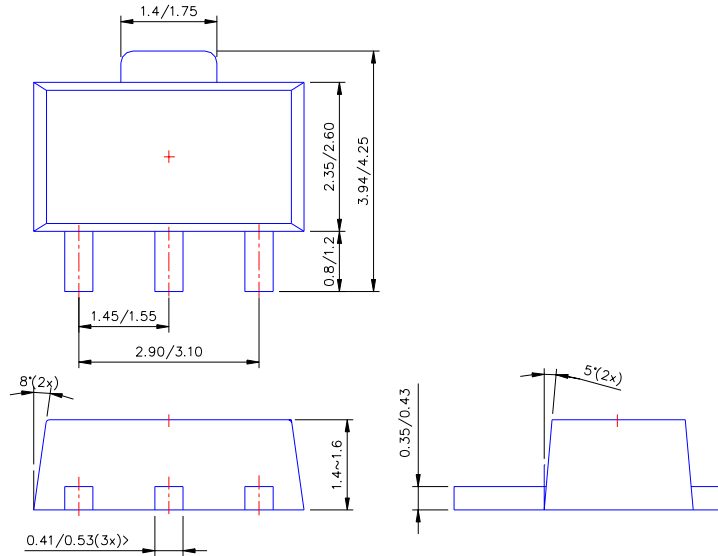

(6) TO92-3L

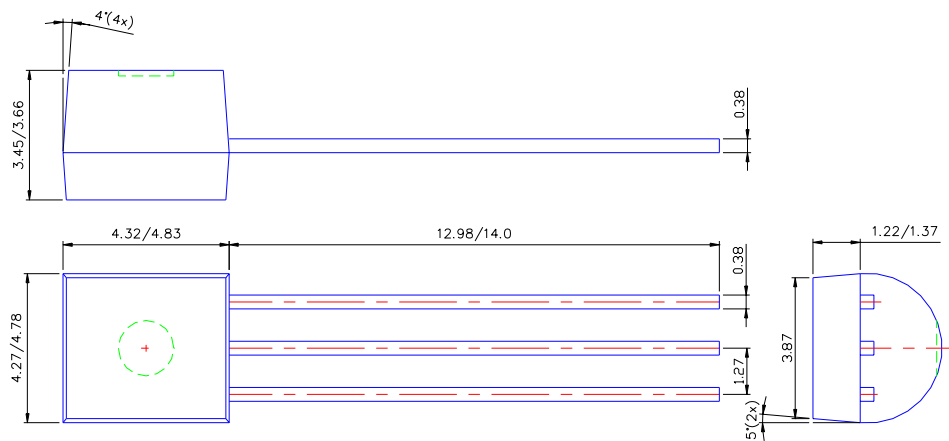

Marking Information

(1) SOT23/SOT25/SC59

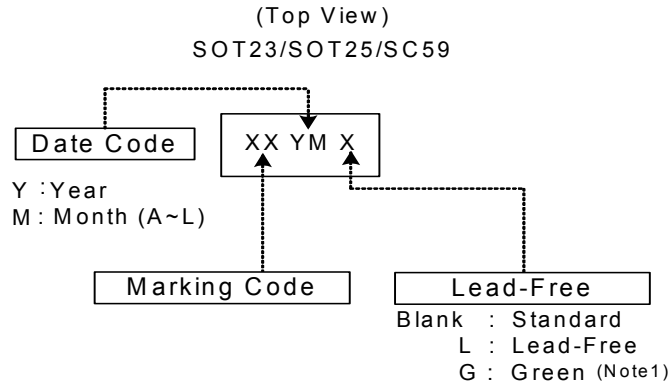

Note: 1. Only for SOT23

(2) SOP-8L

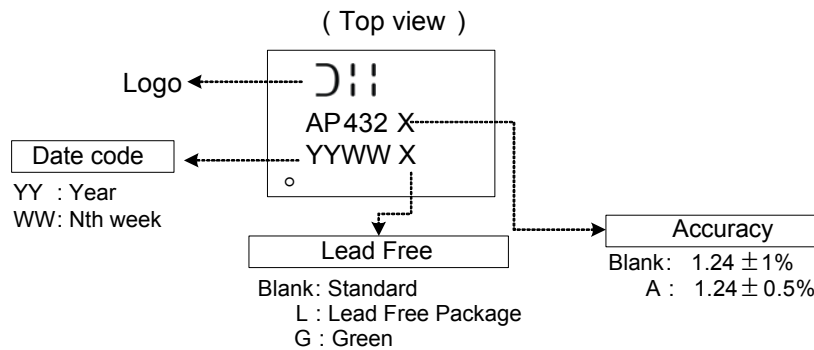

(3) SOT89-3L

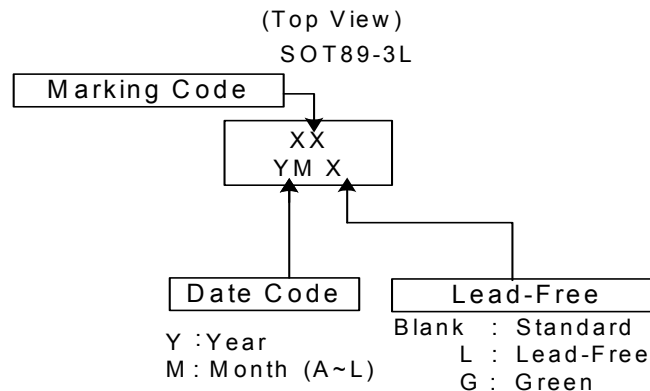

Marking Information (Continued)

(4) TO92-3L

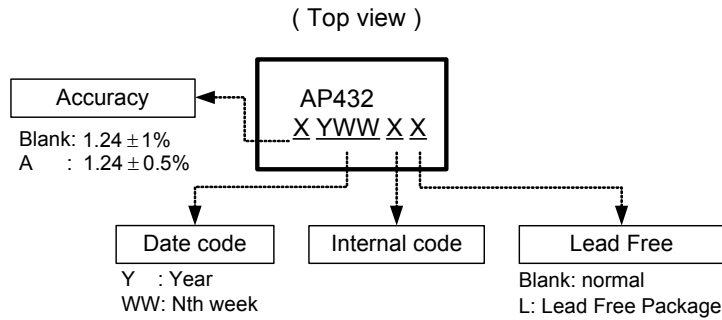

Marking Code Table

Device	Package(Note 8)	Marking Code	Date Code
AP432SA	SOT23	D3	YM
AP432ASA	SOT23	D4	YM
AP432Q	SOT25	B7	YM
AP432AQ	SOT25	B8	YM
AP432W	SC59	B3	YM
AP432AW	SC59	B4	YM
AP432R	SC59	B5	YM
AP432AR	SC59	B6	YM
AP432Y	SOT89	B1	YM
AP432AY	SOT89	B2	YM

Notes: 8. For Packaging Details, go to our website at <http://www.diodes.com/datasheets/ap02007.pdf>.

IMPORTANT NOTICE

Diodes Incorporated and its subsidiaries reserve the right to make modifications, enhancements, improvements, corrections or other changes without further notice to any product herein. Diodes Incorporated does not assume any liability arising out of the application or use of any product described herein; neither does it convey any license under its patent rights, nor the rights of others. The user of products in such applications shall assume all risks of such use and will agree to hold Diodes Incorporated and all the companies whose products are represented on our website, harmless against all damages.

LIFE SUPPORT

Diodes Incorporated products are not authorized for use as critical components in life support devices or systems without the expressed written approval of the President of Diodes Incorporated.