

HIGH RIPPLE-REJECTION LOW DROPOUT CMOS VOLTAGE REGULATOR

S-L2980 Series

The S-L2980 series is a positive voltage regulator with a low dropout voltage, high output voltage accuracy, and low current consumption developed based on CMOS technology.

A built-in low on-resistance transistor provides a low dropout voltage and a large output current. A shutdown circuit ensures long battery life.

Various types of output capacitors can be used in the S-L2980 series compared with the former CMOS voltage regulators. A small ceramic capacitor can also be used.

■ Features

- Output voltage: 1.5 V to 6.0 V, selectable in 0.1 V steps
- High accuracy output voltage: $\pm 2.0\%$
- Low dropout voltage: 120 mV typ.
(@ 3.0 V output product, $I_{OUT}=50$ mA)
- Low current consumption: During operation: 90 μ A typ., 140 μ A max.
During shutdown: 0.1 μ A typ., 1.0 μ A max.
- High peak current capability: 150 mA output is possible. (@ $V_{IN} \geq V_{OUT(S)} + 1.0$ V)^{*1}
- Built-in shutdown circuit: Ensure long battery life.
- Low ESR capacitor: A 1.0 μ F capacitor can be used as the output capacitor.
(A 2.2 μ F capacitor can be used as the output capacitor for the products whose output voltage is 1.7 V or less.)
- High ripple rejection: 70 dB typ. (@ 1.0 kHz)
- Small package: SOT-23-5, 5-Pin SON(A)

*1. Attention should be paid to the power dissipation of the package when the load is large.

■ Applications

- Power supply for battery-powered devices
- Power supply for personal communication devices
- Power supply for home electric/electronic appliances
- Power supply for cellular phones

■ Packages

- SOT-23-5 (Package drawing code: MP005-A)
- 5-Pin SON(A) (Package drawing code: PN005-A)

■ Block Diagram

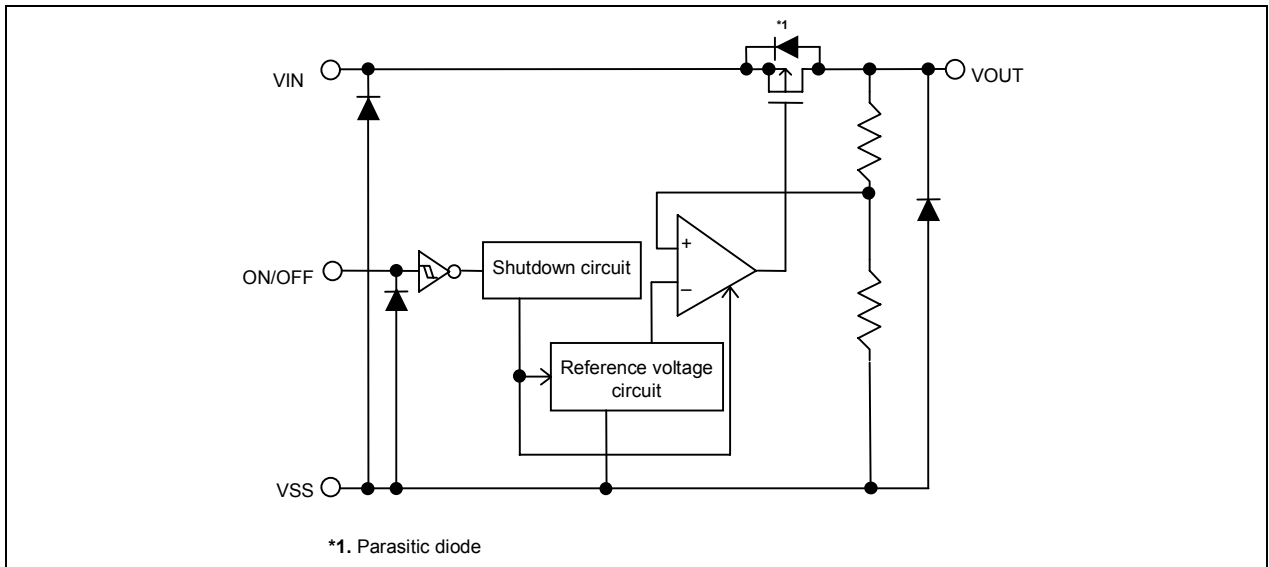
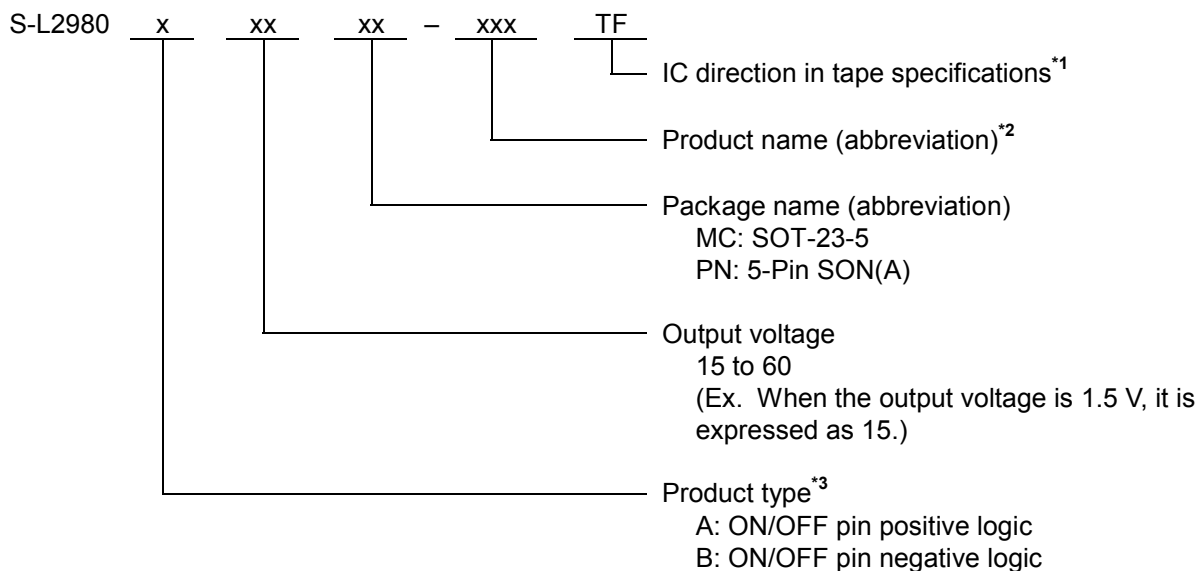

Figure 1

■ Product Code Structure

- The product types, output voltage and packages for S-L2980 Series can be selected at the user's request. Please refer to the "Product name" for the construction of the product name and "Product name list" for the full product names.

1. Product name



- *1. Please refer to the taping specifications at the end of this book.
- *2. Please refer to the product name list.
- *3. Please refer to the "3. Shutdown pin (ON/OFF pin)" in the operation.

2. Product name list

Table 1

Output Voltage	SOT-23-5	5-Pin SON(A)
1.5 V \pm 2.0%	—	S-L2980A15PN-C6ATF
1.7 V \pm 2.0%	S-L2980A17MC-C6CTF	S-L2980A17PN-C6CTF
1.8 V \pm 2.0%	S-L2980A18MC-C6DTF	S-L2980A18PN-C6DTF
1.9 V \pm 2.0%	—	S-L2980A19PN-C6ETF
2.5 V \pm 2.0%	S-L2980A25MC-C6KTF	S-L2980A25PN-C6KTF
2.7 V \pm 2.0%	S-L2980A27MC-C6MTF	S-L2980A27PN-C6MTF
2.8 V \pm 2.0%	S-L2980A28MC-C6NTF	S-L2980A28PN-C6NTF
2.9 V \pm 2.0%	—	S-L2980A29PN-C6OTF
3.0 V \pm 2.0%	S-L2980A30MC-C6PTF	S-L2980A30PN-C6PTF
3.1 V \pm 2.0%	S-L2980A31MC-C6QTF	—
3.2 V \pm 2.0%	S-L2980A32MC-C6RTF	—
3.3 V \pm 2.0%	S-L2980A33MC-C6STF	S-L2980A33PN-C6STF
3.6 V \pm 2.0%	S-L2980A36MC-C6VTS	—
3.8 V \pm 2.0%	S-L2980A38MC-C6XTF	S-L2980A38PN-C6XTF
4.0 V \pm 2.0%	S-L2980A40MC-C6ZTF	S-L2980A40PN-C6ZTF
4.1 V \pm 2.0%	S-L2980A41MC-C7ATF	—
4.4 V \pm 2.0%	S-L2980A44MC-C7DTF	—
4.5 V \pm 2.0%	—	S-L2980A45PN-C7ETF
4.8 V \pm 2.0%	S-L2980A48MC-C7HTF	—
5.0 V \pm 2.0%	S-L2980A50MC-C7JTF	S-L2980A50PN-C7JTF

Remark Please contact the SII marketing department for products with an output voltage other than those specified above or type B products.

■ Pin Configurations

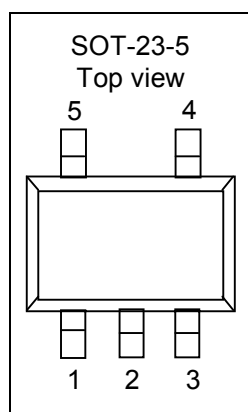

Figure 2

Table 2

Pin No.	Symbol	Pin Description
1	V _{IN}	Input voltage pin
2	V _{SS}	GND pin
3	ON/OFF	Shutdown pin
4	NC ^{*1}	No connection
5	V _{OUT}	Output voltage pin

*1. The NC pin is electrically open.
The NC pin can be connected to V_{IN} or V_{SS}.

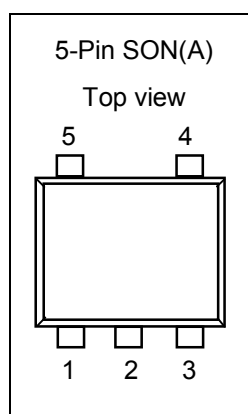

Figure 3

Table 3

Pin No.	Symbol	Pin Description
1	NC ^{*1}	No connection
2	V _{SS}	GND pin
3	ON/OFF	Shutdown pin
4	V _{IN}	Input voltage pin
5	V _{OUT}	Output voltage pin

*1. The NC pin is electrically open.
The NC pin can be connected to V_{IN} or V_{SS}.

■ Absolute Maximum Ratings

Table 4

(Ta=25°C unless otherwise specified)

Items	Symbols	Absolute Maximum Ratings		Units
Input voltage	V _{IN}	V _{SS} -0.3 to V _{SS} +12		V
	V _{ON/OFF}	V _{SS} -0.3 to V _{SS} +12		
Output voltage	V _{OUT}	V _{SS} -0.3 to V _{IN} +0.3		
Power dissipation	P _D	SOT-23-5	300	mW
		5-Pin SON(A)	150	
Operating ambient temperature	T _{opr}	-40 to +85		°C
Storage ambient temperature	T _{stg}	-40 to +125		

Caution The absolute maximum ratings are rated values exceeding which the product could suffer physical damage. These values must therefore not be exceeded under any conditions.

■ Electrical Characteristics

Table 5

(Ta=25°C unless otherwise specified)

Items	Symbols	Conditions	Min.	Typ.	Max.	Units	Test circuits	
Output voltage*1	$V_{OUT(E)}$	$V_{IN} = V_{OUT(S)} + 1.0 \text{ V}$, $I_{OUT} = 50 \text{ mA}$	$V_{OUT(S)} \times 0.98$	$V_{OUT(S)}$	$V_{OUT(S)} \times 1.02$	V	1	
Output current*2	I_{OUT}	$V_{IN} \geq V_{OUT(S)} + 1.0 \text{ V}$	150*5	—	—	mA	3	
Dropout voltage*3	V_{drop}	$I_{OUT} = 50 \text{ mA}$	$1.5 \text{ V} \leq V_{OUT(S)} \leq 1.7 \text{ V}$	—	0.17	0.33	V	1
			$1.8 \text{ V} \leq V_{OUT(S)} \leq 1.9 \text{ V}$	—	0.16	0.29		
			$2.0 \text{ V} \leq V_{OUT(S)} \leq 2.4 \text{ V}$	—	0.15	0.26		
			$2.5 \text{ V} \leq V_{OUT(S)} \leq 2.9 \text{ V}$	—	0.13	0.20		
			$3.0 \text{ V} \leq V_{OUT(S)} \leq 3.2 \text{ V}$	—	0.12	0.15		
			$3.3 \text{ V} \leq V_{OUT(S)} \leq 6.0 \text{ V}$	—	0.11	0.14		
Line regulation	$\frac{\Delta V_{OUT1}}{\Delta V_{IN} \cdot V_{OUT}}$	$V_{OUT(S)} + 0.5 \text{ V} \leq V_{IN} \leq 10 \text{ V}$, $I_{OUT} = 50 \text{ mA}$	—	0.05	0.2	% / V	1	
Load regulation	ΔV_{OUT2}	$V_{IN} = V_{OUT(S)} + 1.0 \text{ V}$ $1.0 \text{ mA} \leq I_{OUT} \leq 80 \text{ mA}$	—	12	40	mV		
Output voltage temperature coefficient*4	$\frac{\Delta V_{OUT}}{\Delta T_a \cdot V_{OUT}}$	$V_{IN} = V_{OUT(S)} + 1.0 \text{ V}$, $I_{OUT} = 50 \text{ mA}$, $-40^\circ\text{C} \leq T_a \leq 85^\circ\text{C}$	—	± 100	—	ppm / °C		
Current consumption during operation	I_{SS1}	$V_{IN} = V_{OUT(S)} + 1.0 \text{ V}$, ON/OFF pin=ON, no load	—	90	140	μA	2	
Current consumption when shutdown	I_{SS2}	$V_{IN} = V_{OUT(S)} + 1.0 \text{ V}$, ON/OFF pin =OFF, no load	—	0.1	1.0			
Input voltage	V_{IN}	—	2.0	—	10	V	—	
ON/OFF pin input voltage "H"	V_{SH}	$V_{IN} = V_{OUT(S)} + 1.0 \text{ V}$, $R_L = 1.0 \text{ k}\Omega$	1.5	—	—			
ON/OFF pin input voltage "L"	V_{SL}	$V_{IN} = V_{OUT(S)} + 1.0 \text{ V}$, $R_L = 1.0 \text{ k}\Omega$	—	—	0.3			
ON/OFF pin input current "H"	I_{SH}	$V_{IN} = V_{OUT(S)} + 1.0 \text{ V}$, $V_{ON/OFF} = 7.0 \text{ V}$	-0.1	—	0.1	μA	4	
ON/OFF pin input current "L"	I_{SL}	$V_{IN} = V_{OUT(S)} + 1.0 \text{ V}$, $V_{ON/OFF} = 0 \text{ V}$	-0.1	—	0.1			
Ripple rejection	RR	$V_{IN} = V_{OUT(S)} + 1.0 \text{ V}$ $f = 1.0 \text{ kHz}$ $\Delta V_{rip} = 0.5 \text{ V rms}$ $I_{OUT} = 50 \text{ mA}$	$1.5 \text{ V} \leq V_{OUT(S)} \leq 3.3 \text{ V}$	—	70	—	dB	5
			$3.4 \text{ V} \leq V_{OUT(S)} \leq 5.0 \text{ V}$	—	65	—		
			$5.1 \text{ V} \leq V_{OUT(S)} \leq 6.0 \text{ V}$	—	60	—		

*1. $V_{OUT(S)}$: Specified output voltage

$V_{OUT(E)}$: Actual output voltage at the fixed load

The output voltage when fixing $I_{OUT}(=50 \text{ mA})$ and inputting $V_{OUT(S)} + 1.0 \text{ V}$

*2. Output current at which output voltage becomes 95% of V_{OUT} after gradually increasing output current.

*3. $V_{drop} = V_{IN1} - (V_{OUT} \times 0.98)$

V_{IN1} is the input voltage at which output voltage becomes 98% of V_{OUT} after gradually decreasing input voltage.

*4. A change in temperatures [mV/°C] is calculated using the following equation.

$$\frac{\Delta V_{OUT}}{\Delta T_a} [\text{mV}/^\circ\text{C}]^{*1} = V_{OUT(S)} [\text{V}]^{*2} \times \frac{\Delta V_{OUT}}{\Delta T_a \cdot V_{OUT}} [\text{ppm}/^\circ\text{C}]^{*3} \div 1000$$

*1. Change in temperature of output voltage

*2. Specified output voltage

*3. Output voltage temperature coefficient

*5. The output current can be supplied at least to this value.

Due to restrictions on the package power dissipation, this value may not be satisfied

Attention should be paid to the power dissipation of the package when the load is large.

This specification is guaranteed by design.

■ Test Circuits

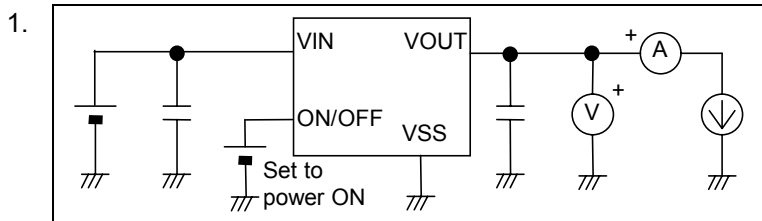

Figure 4

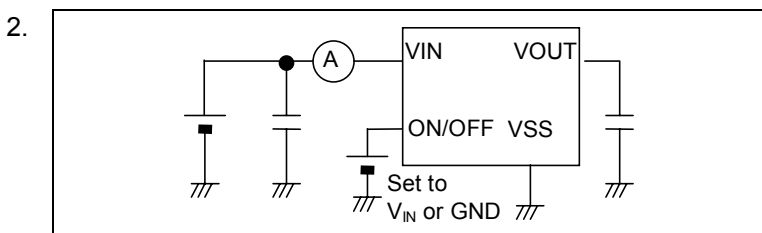

Figure 5

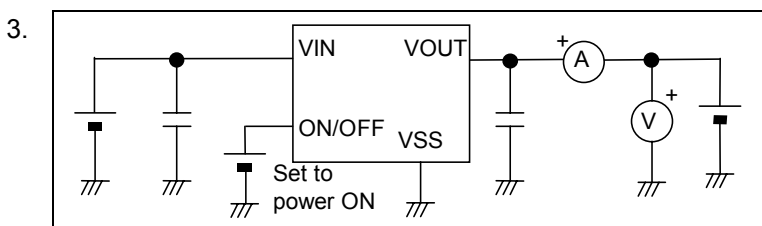

Figure 6

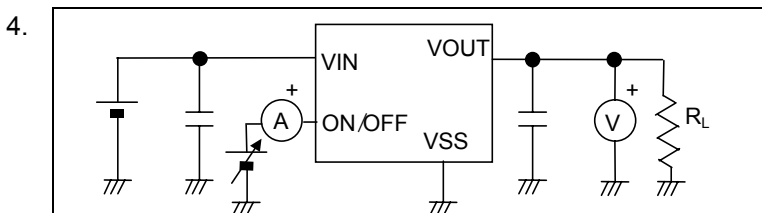

Figure 7

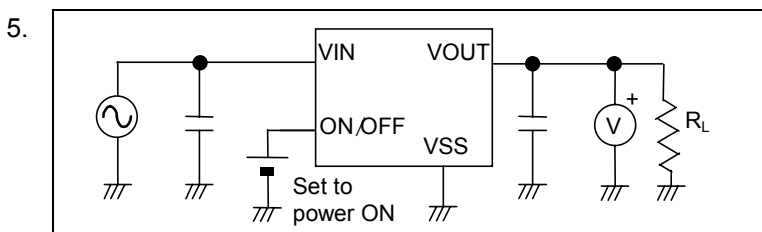

Figure 8

■ Standard Circuit

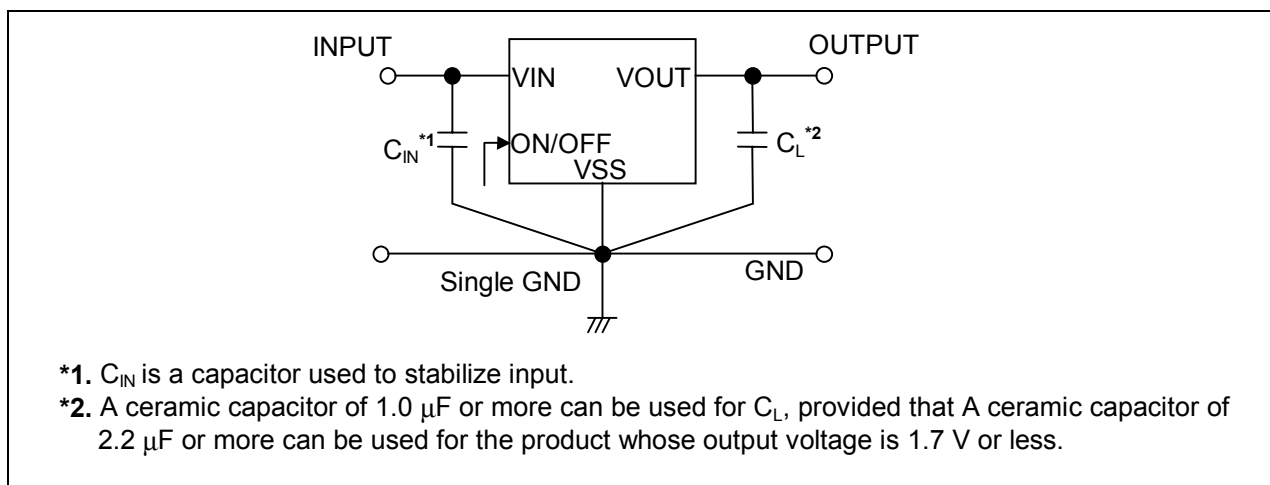

Figure 9

Caution The above connection diagram and constant will not guarantees successful operation.
Perform through evaluation using the actual application to set the constant.

■ Application Conditions

Input capacitor (C_{IN}) :	0.47 μF or more
Input series resistance (R_{IN}) :	10 Ω or less
Output capacitor (C_L) :	1.0 μF or more *1
Equivalent Series Resistance (ESR) for output capacitor:	10 Ω or less

*1. If the product whose output voltage is 1.7 V or less will be used, C_L is 2.2 μF or more.

■ Explanation of Terms

1. Low dropout voltage regulator

The low dropout voltage regulator is a voltage regulator whose dropout voltage is low due to its low on-resistance built-in transistor.

2. Low ESR

Low ESR means the Equivalent Series Resistance of a capacitor is small. The low ESR ceramics output capacitor (C_L) can be used in the S-L2980 Series. The ESR of the C_L should be 10 Ω or less.

3. Output voltage (V_{OUT})

The accuracy of the output voltage is ensured at $\pm 2.0\%$ under the specified conditions of fixed input voltage^{*1}, fixed output current, and fixed temperature.

*1. Differs depending upon the product.

Caution If the above conditions change, the output voltage value may vary and exceed the accuracy range of the output voltage. Please see the electrical characteristics and attached characteristics data for details.

4. Line regulation $\left(\frac{\Delta V_{OUT1}}{\Delta V_{IN} \bullet V_{OUT}} \right)$

Indicates the dependency of the output voltage on the input voltage. That is, the values show how much the output voltage changes due to a change in the input voltage with the output current remaining unchanged.

5. Load regulation (ΔV_{OUT2})

Indicates the dependency of the output voltage on the output current. That is, the values show how much the output voltage changes due to a change in the output current with the input voltage remaining unchanged.

6. Dropout voltage (V_{drop})

Indicates the difference between the input voltage (V_{IN1}) and output voltage when the output voltage falls to 98% of the output voltage ($V_{OUT(E)}$) by gradually decreasing the input voltage.

$$V_{drop} = V_{IN1} - (V_{OUT(E)} \times 0.98)$$

7. Temperature coefficient of output voltage $\left(\frac{\Delta V_{OUT}}{\Delta T_a \bullet V_{OUT}} \right)$

The shadowed area in Figure 10 is the range where V_{OUT} varies in the operating temperature range when the temperature coefficient of the output voltage is ± 100 ppm/ $^{\circ}\text{C}$.

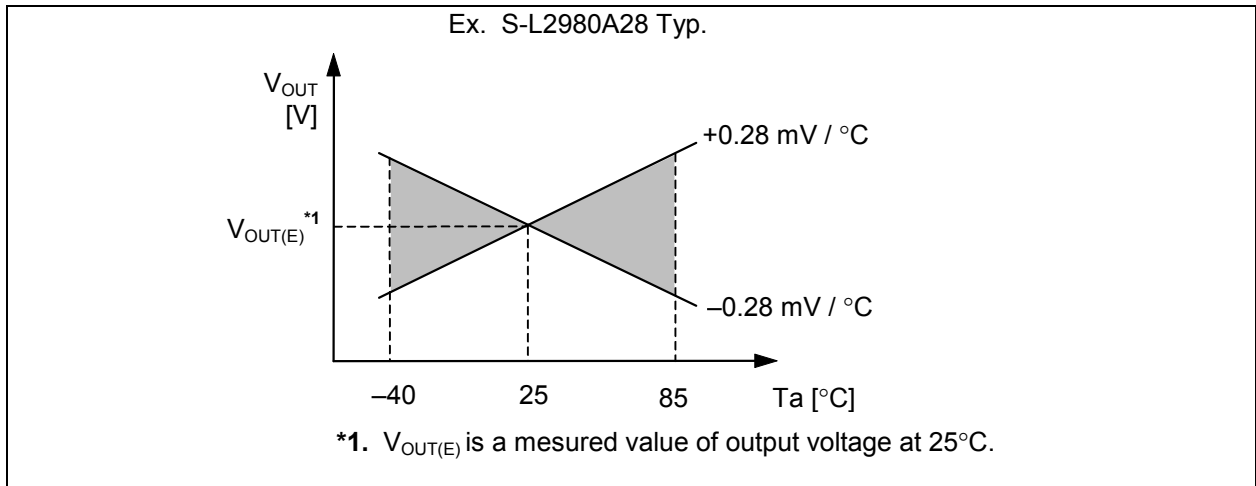

Figure 10

A change in the temperatures of output voltage [mV/ $^{\circ}\text{C}$] is calculated using the following equation.

$$\frac{\Delta V_{OUT}}{\Delta T_a} [\text{mV}/^{\circ}\text{C}]^{*1} = V_{OUT(S)} [\text{V}]^{*2} \times \frac{\Delta V_{OUT}}{\Delta T_a \bullet V_{OUT}} [\text{ppm}/^{\circ}\text{C}]^{*3} \div 1000$$

- *1. Change in temperatures of output voltage
- *2. Specified output voltage
- *3. Output voltage temperature coefficient

■ Operation

1. Basic operation

Figure 11 shows the block diagram of the S-L2980 Series.

The error amplifier compares the reference voltage (V_{ref}) with the V_{fb} , which is the output voltage resistance-divided by the feedback resistors R_s and R_f . It supplies the output transistor with the gate voltage, necessary to ensure certain output voltage free of any fluctuations of input voltage and temperature.

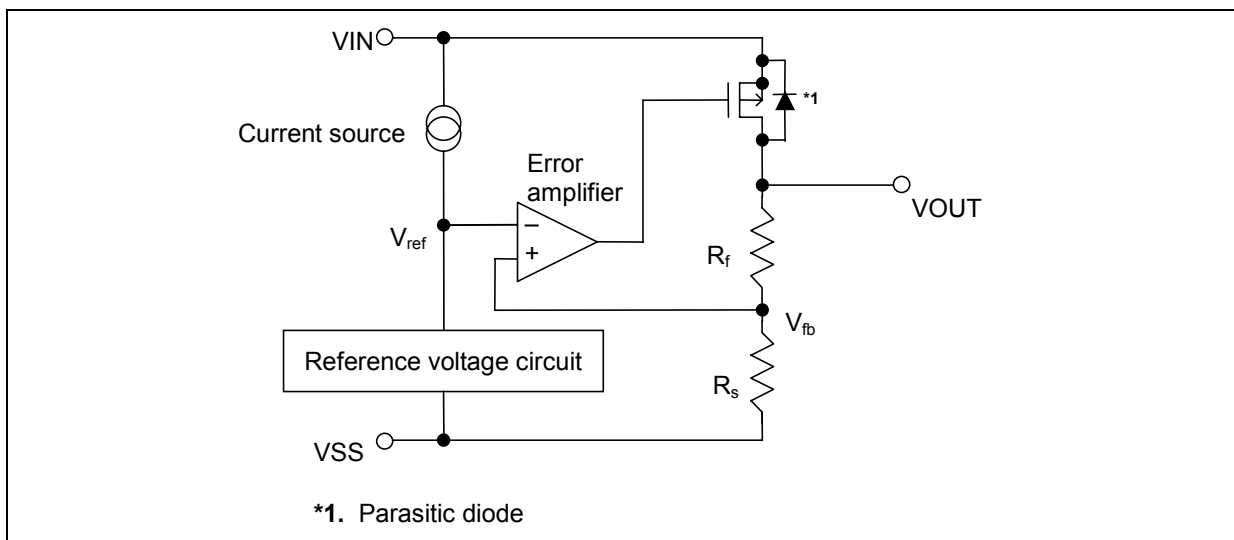

Figure 11

2. Output transistor

The S-L2980 Series uses a low on-resistance P-channel MOS FET as the output transistor. Be sure that V_{OUT} does not exceed $V_{IN}+0.3$ V to prevent the voltage regulator from being broken due to inverse current flowing from VOUT pin through a parasitic diode to VIN pin.

3. Shutdown Pin (ON/OFF Pin)

This pin starts and stops the regulator.

When the ON/OFF pin is turned to the shutdown level, the operation of all internal circuits stops, the built-in P-channel MOS FET output transistor between VIN pin and VOUT pin is turned off to make current consumption drastically reduced. The VOUT pin becomes the VSS level due to internally divided resistance of several hundreds kΩ between the VOUT pin and VSS pin.

Furthermore, the structure of the ON/OFF pin is as shown in Figure 12. Since the ON/OFF pin is neither pulled down nor pulled up internally, do not use it in the floating state. In addition, please note that current consumption increases if a voltage of 0.3 V to VIN-0.3 V is applied to the ON/OFF pin. When the ON/OFF pin is not used, connect it to the VIN pin in case the logic type is "A" and to the VSS pin in case of "B".

Table 6

Logic type	ON/OFF pin	Internal circuit	VOUT pin voltage	Current consumption
A	"H": Power on	Operating	Set value	I _{SS1}
A	"L": Power off	Stop	V _{SS} level	I _{SS2}
B	"H": Power off	Stop	V _{SS} level	I _{SS2}
B	"L": Power on	Operating	Set value	I _{SS1}

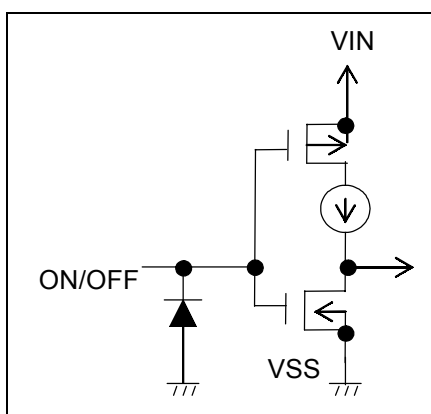

Figure 12

■ Selection of Output Capacitor (C_L)

The S-L2980 series needs an output capacitor between VOUT pin and VSS pin for phase compensation. A ceramic capacitor whose capacitance is 1.0 μF or more*1 can be used. When an OS (Organic Semiconductor) capacitor, a tantalum capacitor or an aluminum electrolyte capacitor is used, the capacitance should be 2.2 μF or more and the ESR should be 10 Ω or less.

Overshoot and undershoot characteristics differ depending upon the magnitude of the output capacitor in use.

Sufficient evaluation including temperature dependency in the actual environment is needed.

*1. If the product whose output voltage is 1.7 V or less will be used, the capacitance should be 2.2 μF or more.

■ Precautions

- Wiring patterns for VIN pin, VOUT pin and GND pin should be designed to hold low impedance. When mounting an output capacitor between the VOUT and VSS pins (C_L) and a capacitor for stabilizing the input between VIN and VSS pins (C_{IN}), the distance from the capacitors to these pins should be as short as possible.
- Note that output voltage may increase when a series regulator is used at low load current (1.0 mA or less).
- Generally a series regulator may cause oscillation, depending on the selection of external parts. The following conditions are recommended for this IC. However, be sure to perform sufficient evaluation under the actual usage conditions for selection, including evaluation of temperature characteristics.

Input capacitor (C_{IN}): 0.47 μ F or more

Output capacitor (C_L): 1.0 μ F or more*1

Equivalent Series Resistance (ESR): 10 Ω or less

Input series resistance (R_{IN}): 10 Ω or less

*1. If the product whose output voltage will be is 1.7 V or less is used, the capacitance should be 2.2 μ F or more.

- A voltage regulator may oscillate when the impedance of the power supply is high and the input capacitor is small or not connected.
- The application condition for input voltage, output voltage and load current should not exceed the package power dissipation.
- Do not apply an electrostatic discharge to this IC that exceeds the performance ratings of the built-in electrostatic protection circuit.
- In determining output current attention should be paid to the output current value specified in the table 5 for electrical characteristics and the footnote *5 of the table 5.
- SII claims no responsibility for any and all disputes arising out of or in connection with any infringement of the products including this IC upon patents owned by a third party.

■ Typical Characteristics

(1) Output voltage versus Output current (When load current increases)

S-L2980A15 (Ta=25°C)

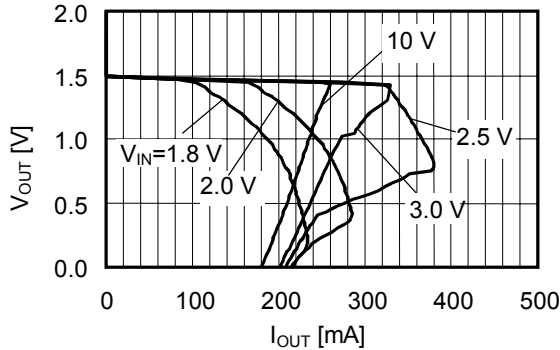

S-L2980A30 (Ta=25°C)

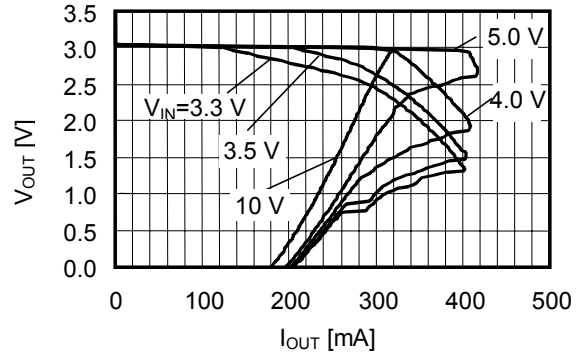

S-L2980A50 (Ta=25°C)

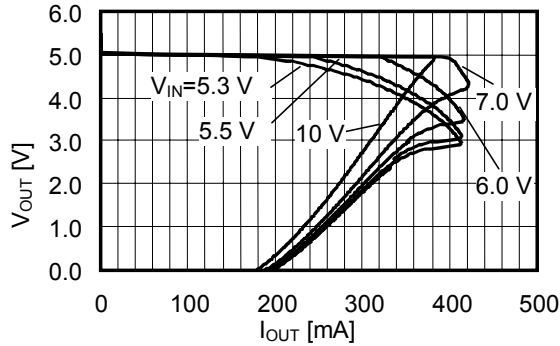

Remark In determining output current, attention should be paid to the followings.
 1) The minimum output current value and footnote *5 in the electrical characteristics.
 2) The package power dissipation

(2) Maximum output current versus Input voltage

S-L2980A15 (Short-circuit protection included)

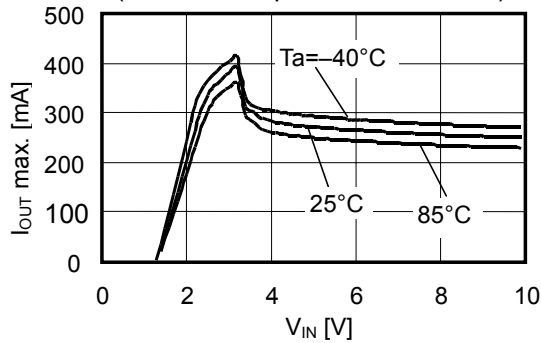

S-L2980A30 (Short-circuit protection included)

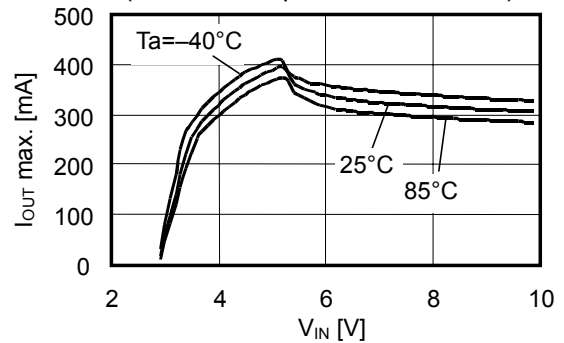

S-L2980A50 (Short circuit protection included)

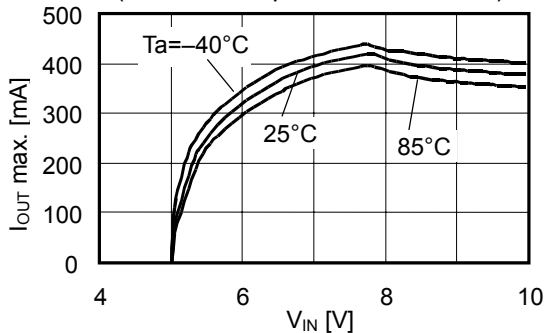

Remark In determining output current, attention should be paid to the followings.
 1) The minimum output current value and footnote *5 in the electrical characteristics.
 2) The package power dissipation

HIGH RIPPLE-REJECTION LOW DROPOUT CMOS VOLTAGE REGULATOR

S-L2980 Series

Rev.2.2_00

(3) Output voltage versus Input voltage

S-L2980A15 (Ta=25°C)

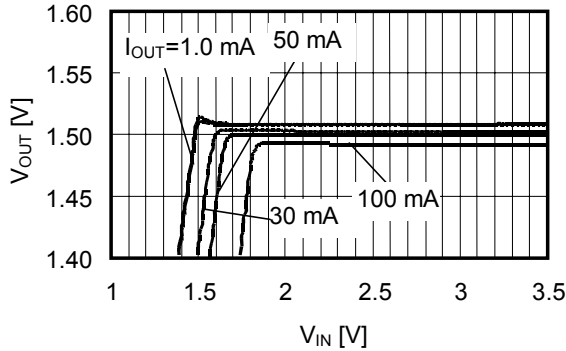

S-L2980A30 (Ta=25°C)

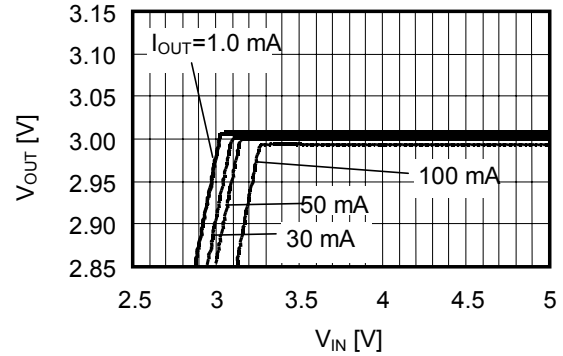

S-L2980A50 (Ta=25°C)

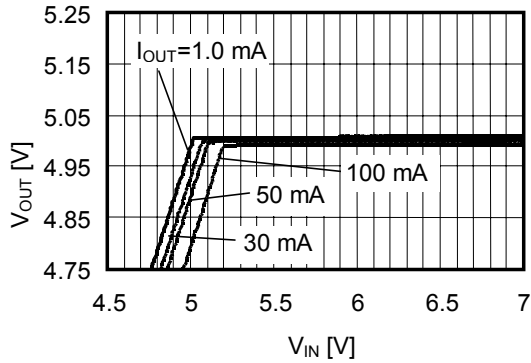

(4) Dropout voltage versus Output voltage

S-L2980A15

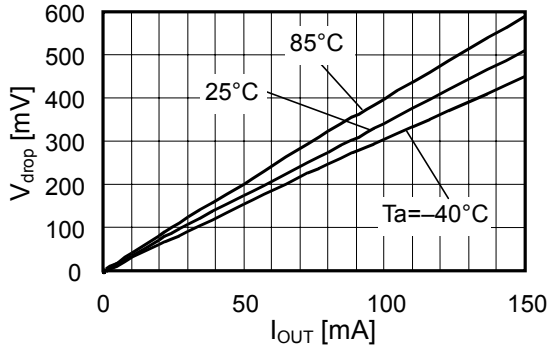

S-L2980A30

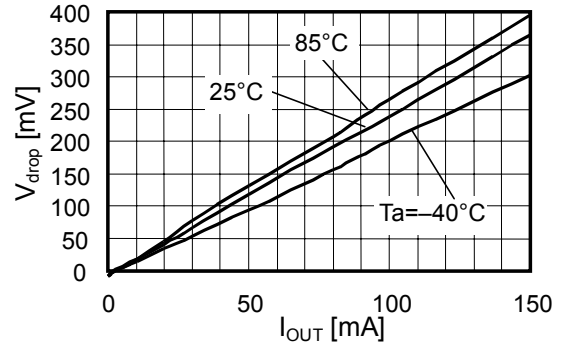

S-L2980A50

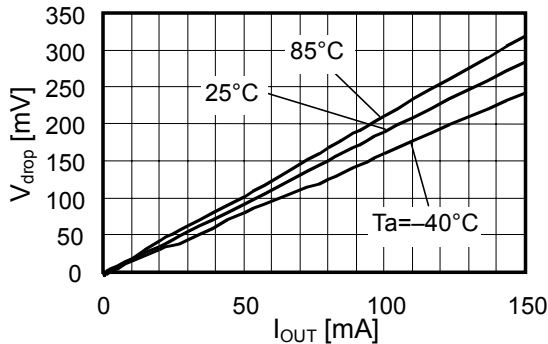

(5) Output voltage versus Ambient Temperature

S-L2980A15

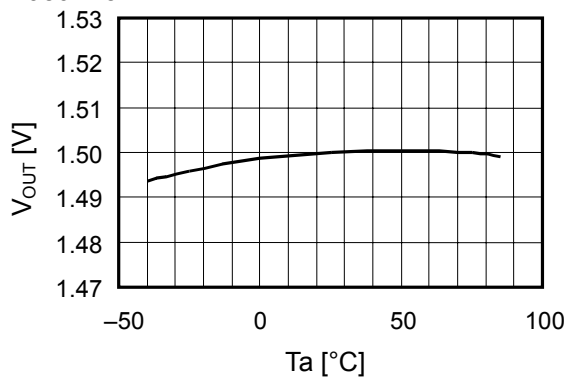

S-L2980A30

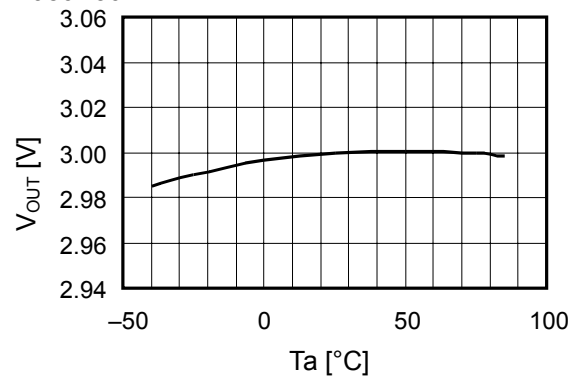

S-L2980A50

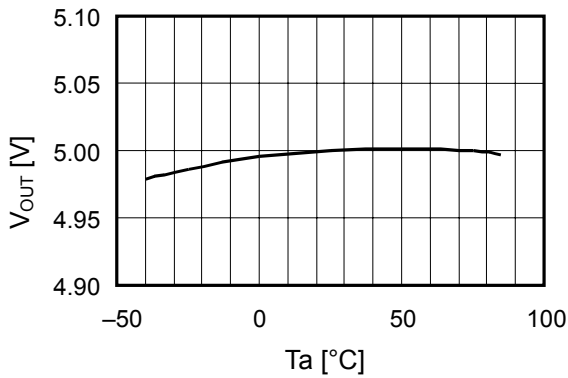

(6) Line regulation versus Ambient Temperature

S-L2980Axx

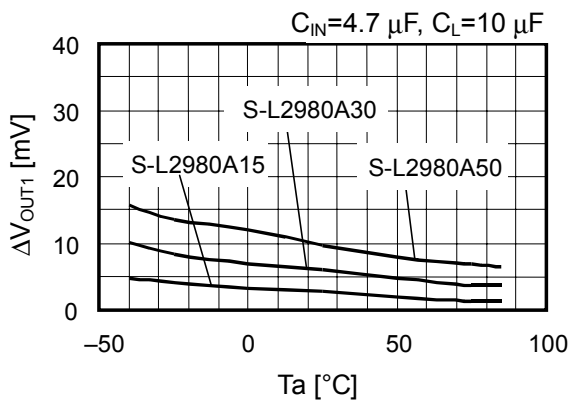

(7) Load regulation versus Ambient Temperature

S-L2980Axx

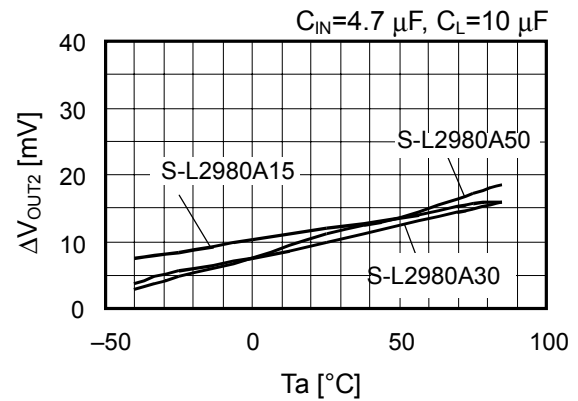

(8) Threshold voltage of ON/OFF pin versus Input voltage

S-L2980A15

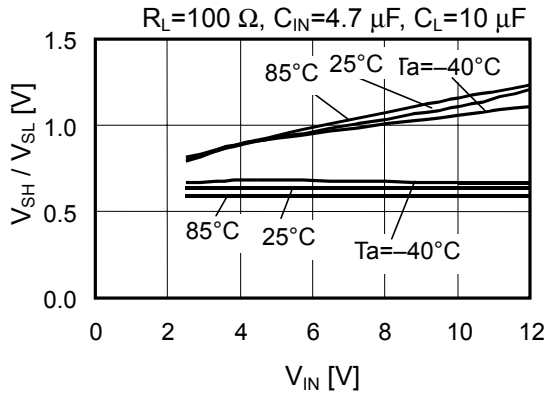

(9) Current consumption versus Input voltage

S-L2980A15

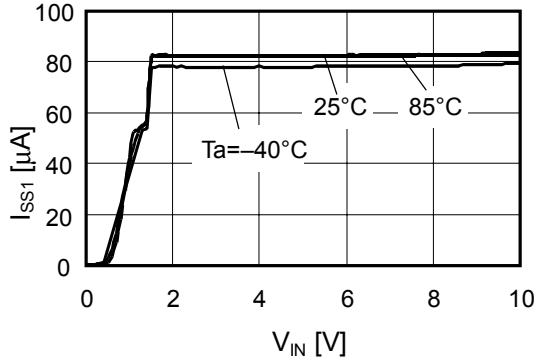

S-L2980A30

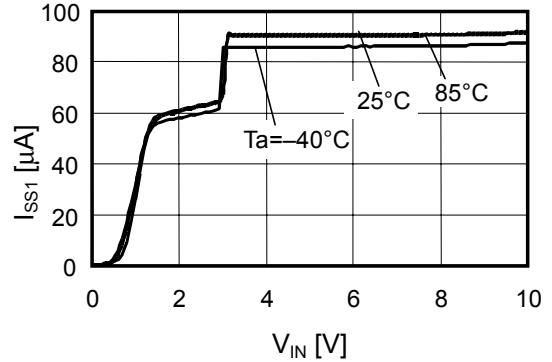

S-L2980A50

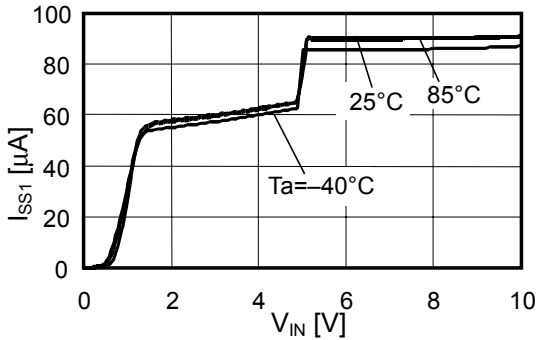

(10) Ripple rejection

S-L2980A30 (Ta=25°C)

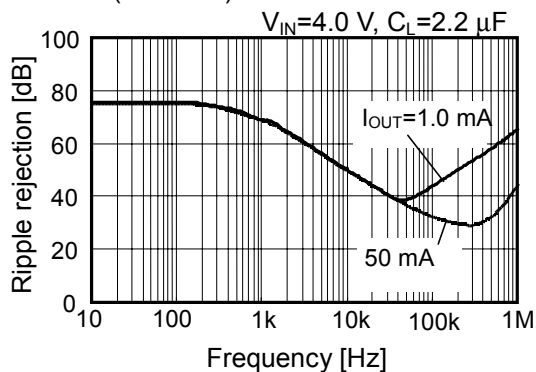

S-L2980A50 (Ta=25°C)

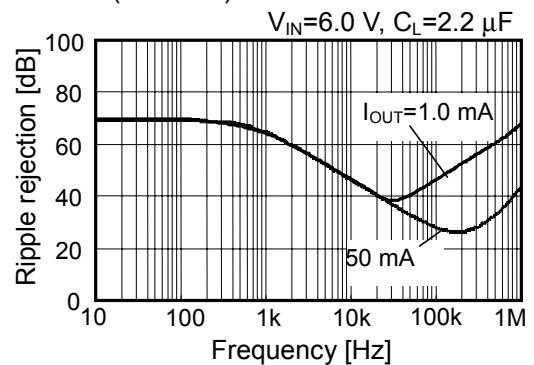

Reference Data

■ Transient Response Characteristics (S-L2980A30MC Typical data: Ta=25°C)

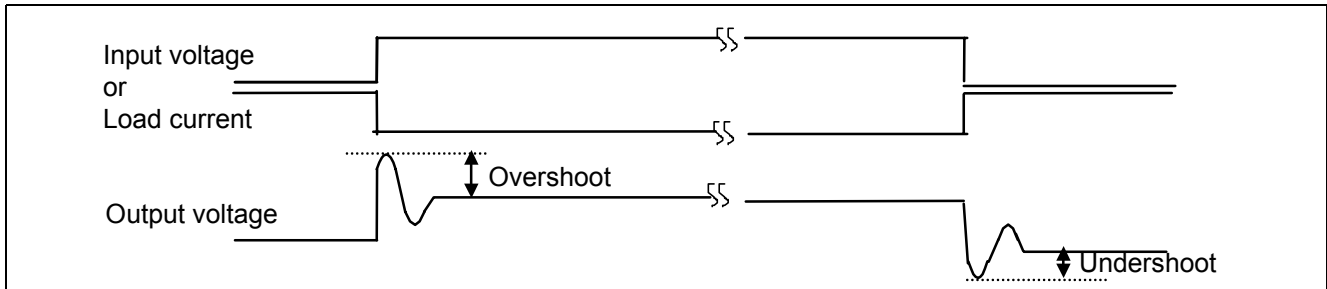

(1) Power source fluctuation

Overshoot

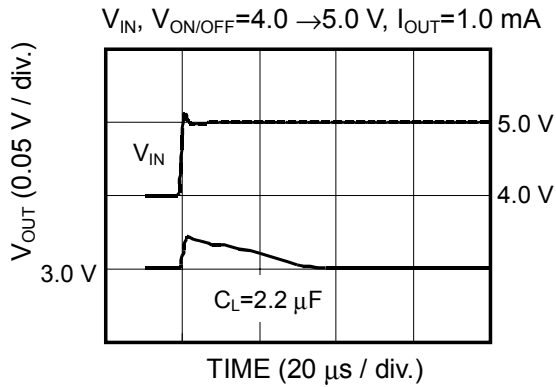

Undershoot

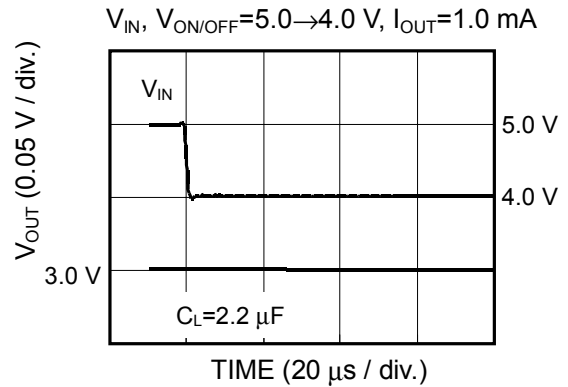

Overshoot

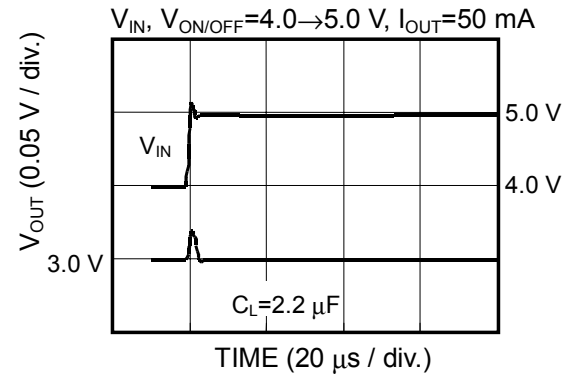

Undershoot

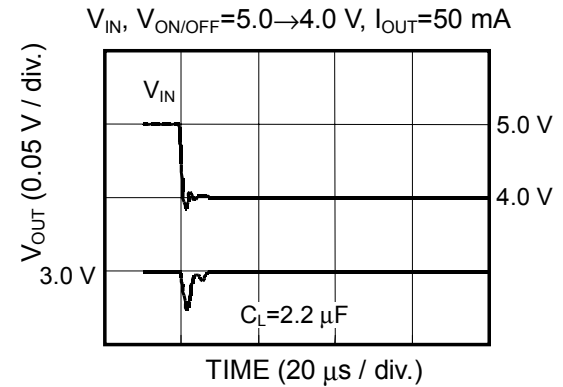

(2) Load fluctuation

Overshoot

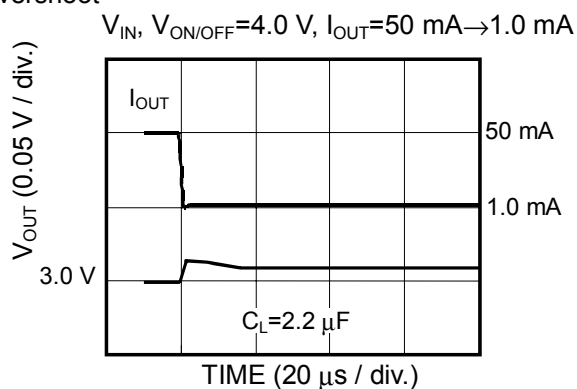

Undershoot

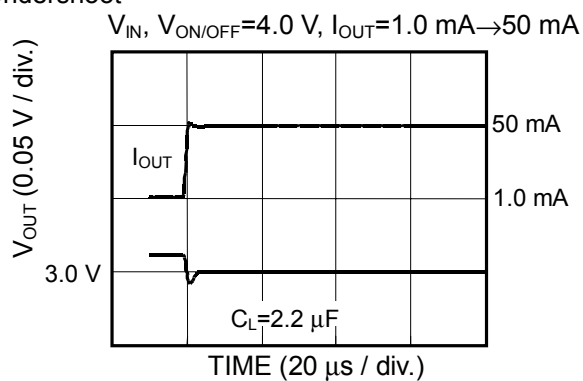

(3) ON/OFF switching

Overshoot

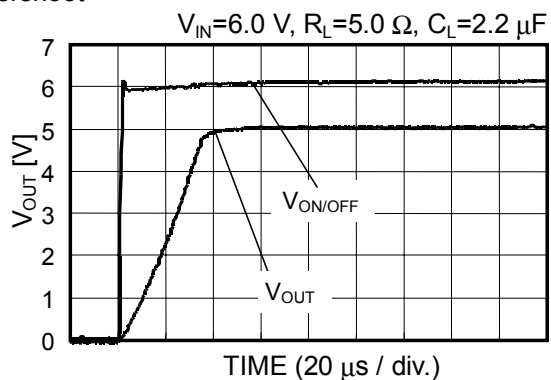

Undershoot

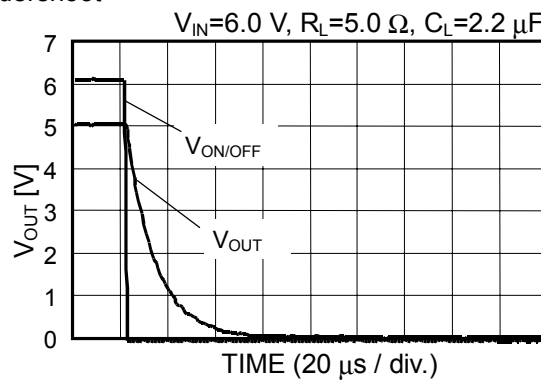

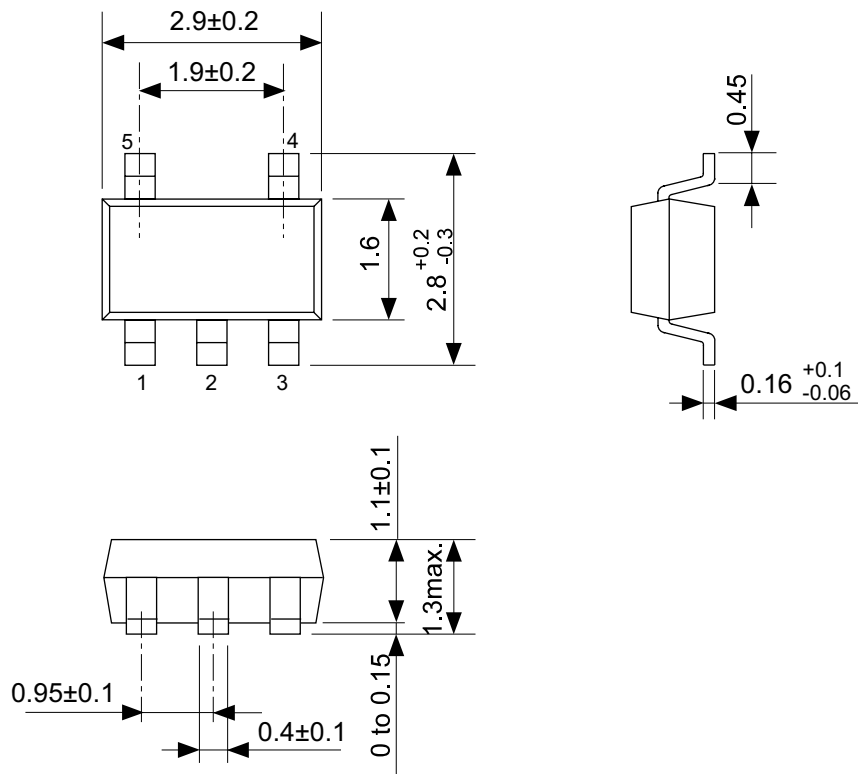

No. MP005-A-P-SD-1.2

TITLE	SOT235-A-PKG Dimensions
No.	MP005-A-P-SD-1.2
SCALE	
UNIT	mm
Seiko Instruments Inc.	

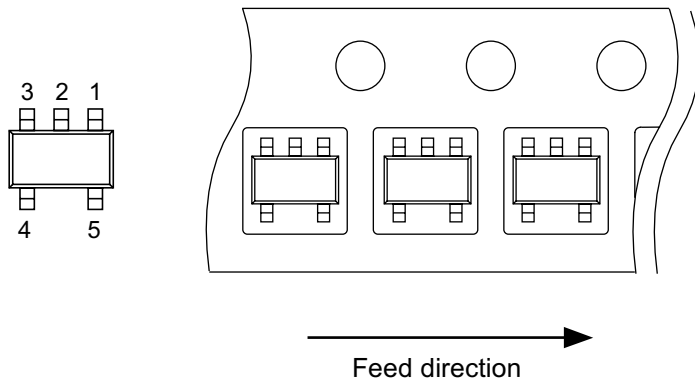
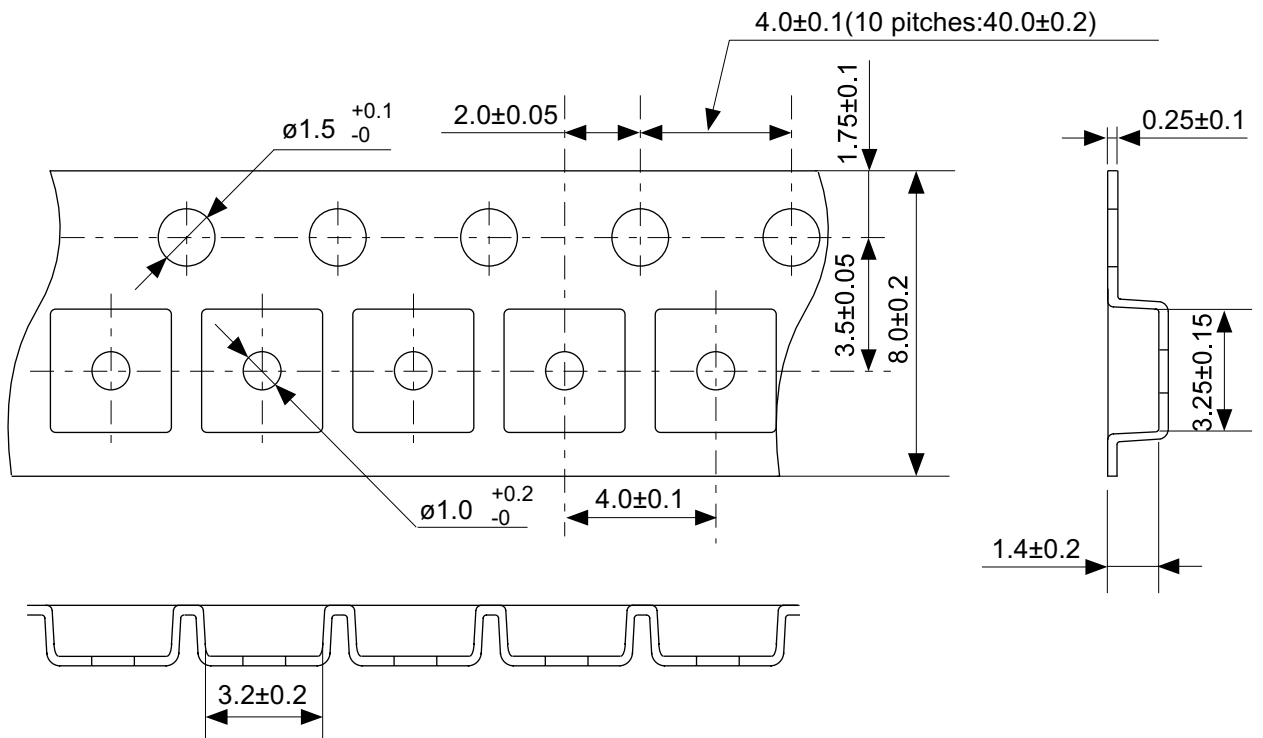

No. MP005-A-C-SD-2.1

TITLE	SOT235-A-Carrier Tape
No.	MP005-A-C-SD-2.1
SCALE	
UNIT	mm
Seiko Instruments Inc.	

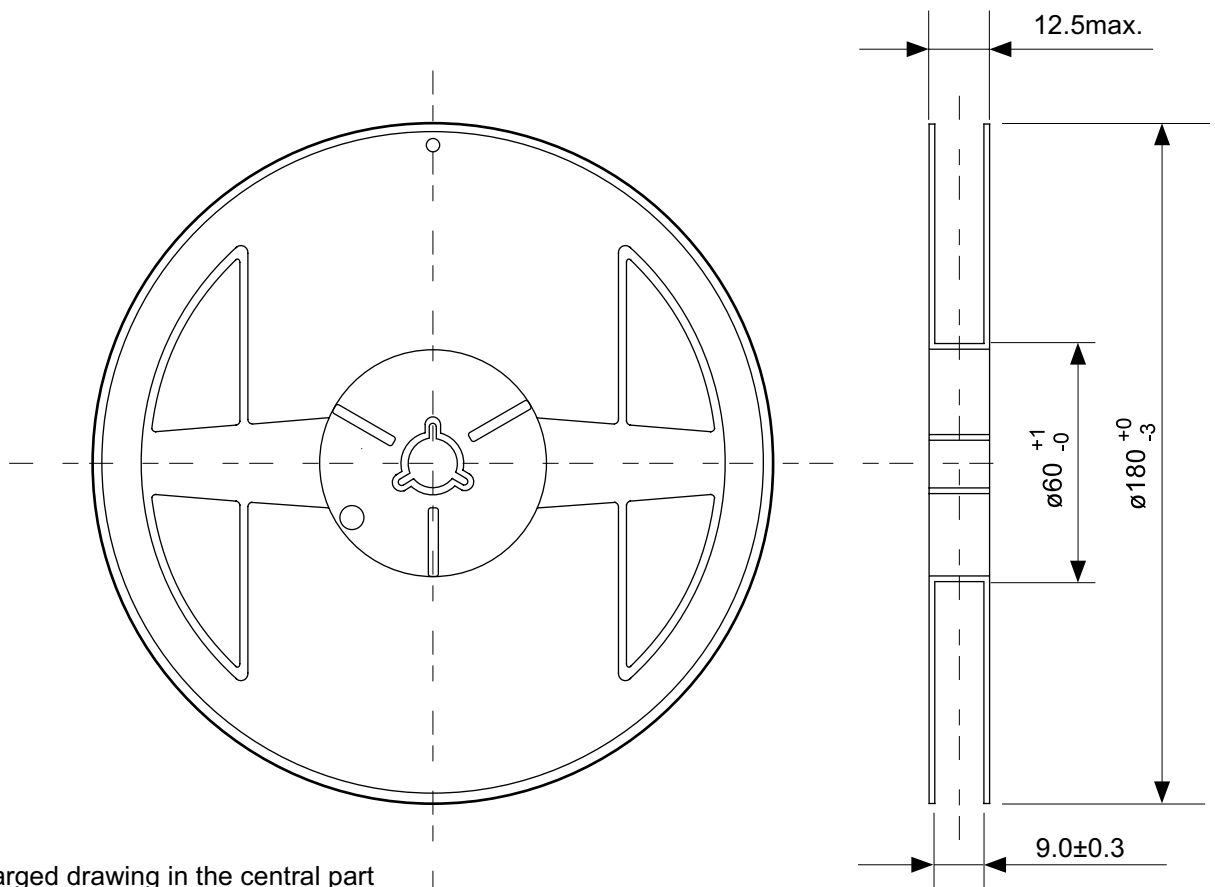

Enlarged drawing in the central part

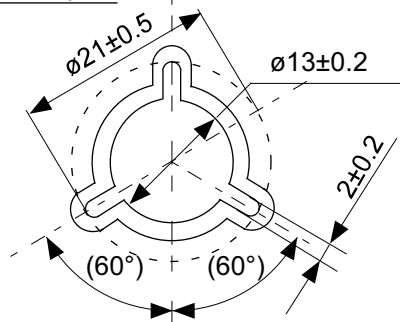

No. MP005-A-R-SD-1.1

TITLE	SOT235-A-Reel		
No.	MP005-A-R-SD-1.1		
SCALE		QTY.	3,000
UNIT	mm		
Seiko Instruments Inc.			

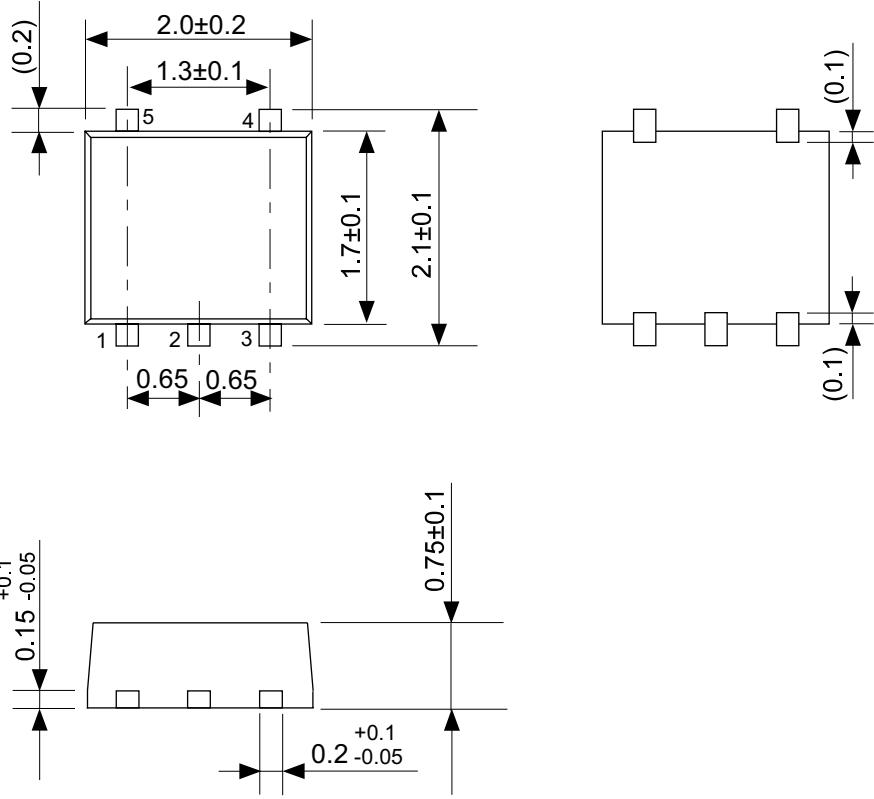

No. PN005-A-P-SD-1.1

TITLE	SON5A-A-PKG Dimensions
No.	PN005-A-P-SD-1.1
SCALE	
UNIT	mm
Seiko Instruments Inc.	

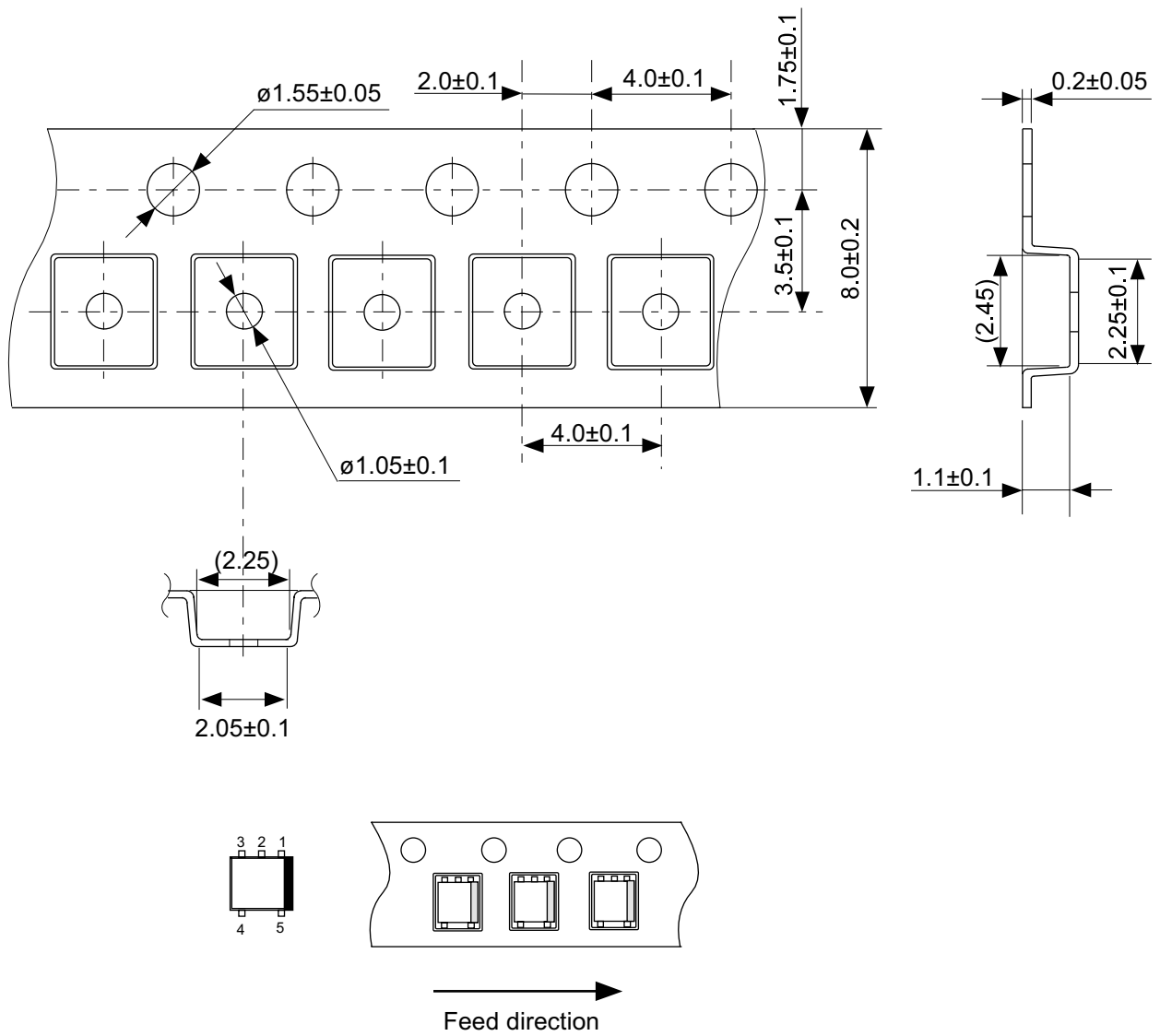

No. PN005-A-C-SD-1.1

TITLE	SON5A-A-Carrier Tape
No.	PN005-A-C-SD-1.1
SCALE	
UNIT	mm
Seiko Instruments Inc.	

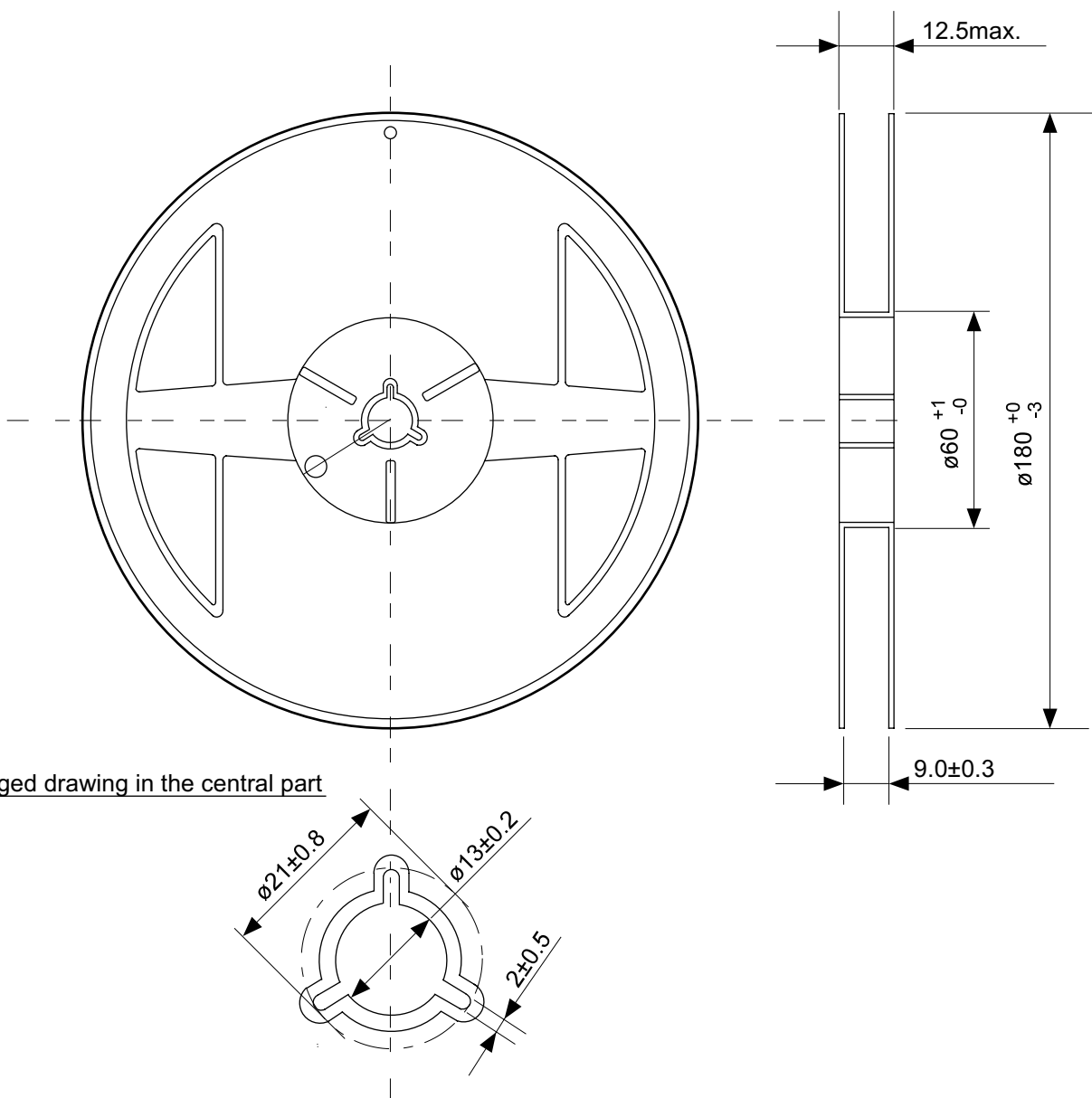

No. PN005-A-R-SD-1.1

TITLE	SON5A-A-Reel		
No.	PN005-A-R-SD-1.1		
SCALE		QTY.	3000
UNIT	mm		
Seiko Instruments Inc.			

- The information described herein is subject to change without notice.
- Seiko Instruments Inc. is not responsible for any problems caused by circuits or diagrams described herein whose related industrial properties, patents, or other rights belong to third parties. The application circuit examples explain typical applications of the products, and do not guarantee the success of any specific mass-production design.
- When the products described herein are regulated products subject to the Wassenaar Arrangement or other agreements, they may not be exported without authorization from the appropriate governmental authority.
- Use of the information described herein for other purposes and/or reproduction or copying without the express permission of Seiko Instruments Inc. is strictly prohibited.
- The products described herein cannot be used as part of any device or equipment affecting the human body, such as exercise equipment, medical equipment, security systems, gas equipment, or any apparatus installed in airplanes and other vehicles, without prior written permission of Seiko Instruments Inc.
- Although Seiko Instruments Inc. exerts the greatest possible effort to ensure high quality and reliability, the failure or malfunction of semiconductor products may occur. The user of these products should therefore give thorough consideration to safety design, including redundancy, fire-prevention measures, and malfunction prevention, to prevent any accidents, fires, or community damage that may ensue.