ULTRA-SMALL PACKAGE BUILT-IN DELAY CIRCUIT HIGH-PRECISION VOLTAGE DETECTOR **S-809xxC Series**

The S-809xxC Series is a high-precision voltage detector developed using CMOS process. The detection voltage is fixed internally with an accuracy of $\pm 2.0\%$. A time delayed reset can be accomplished with the addition of an external capacitor. Two output forms, Nch open-drain and CMOS output, are available.

■ Features

- Ultra-low current consumption 1.0 μA typ. (Detection voltage $\leq 1.4\text{ V}$, at $V_{\text{DD}}=2.0\text{ V}$)
1.1 μA typ. (Detection voltage $\geq 1.5\text{ V}$, at $V_{\text{DD}}=3.5\text{ V}$)
- High-precision detection voltage $\pm 2.0\%$
- Operating voltage range 0.7 V to 10.0 V
- Hysteresis characteristics 5 % typ.
- Detection voltage 1.3 V to 6.0 V (0.1 V step)
- Output forms Nch open-drain output (Active Low)
CMOS output (Active Low)

■ Applications

- Power supply monitor for portable equipment such as notebook PCs, digital still cameras, PDAs and cellular phones
- Constant voltage power monitor for cameras, video equipment and communication equipment
- Power monitor and reset for CPUs and microcomputers

■ Packages

Package name	Drawing code		
	Package	Tape	Reel
SC-82AB	NP004-A	NP004-A	NP004-A
SOT-23-5	MP005-A	MP005-A	MP005-A
SNT-4A	PF004-A	PF004-A	PF004-A

■ Block Diagrams

1. Nch Open-drain Output Products

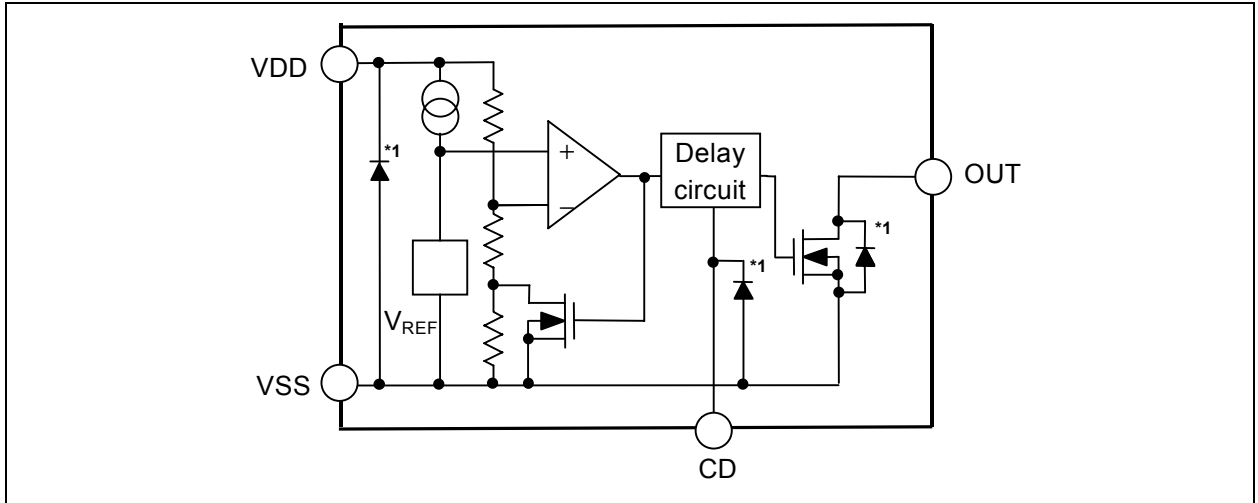

*1. Parasitic diode

Figure 1

2. CMOS Output Products

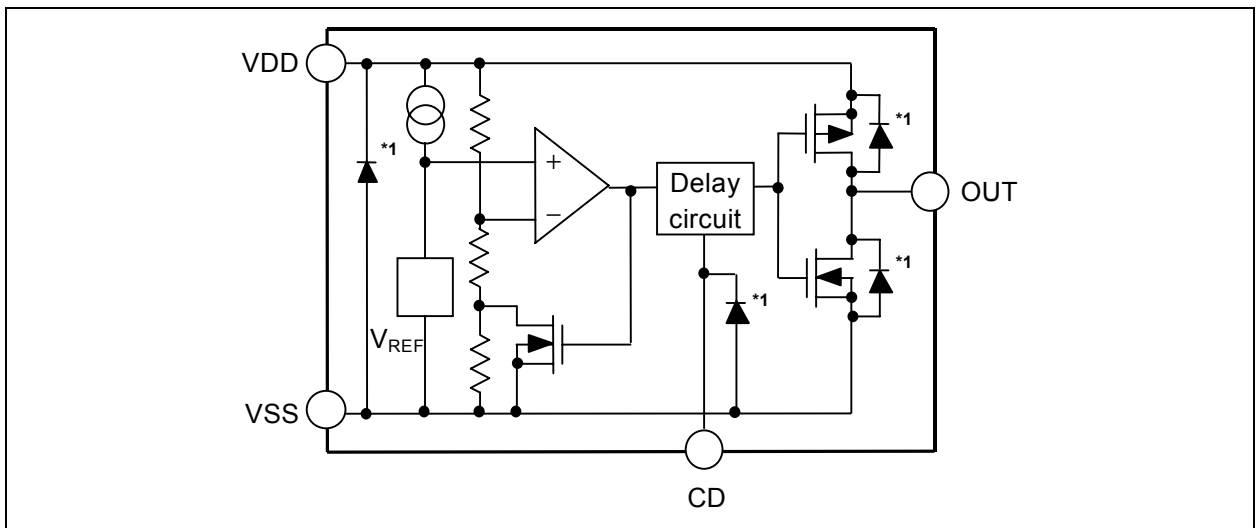

*1. Parasitic diode

Figure 2

■ **Product Name Structure**

The detection voltage, output form and packages for S-809xxC Series can be selected at the user's request. Refer to the "1. **Product Name**" for the construction of the product name and "2. **Product Name List**" for the full product names.

1. Product Name

1-1. SC-82AB, SOT-23-5 packages

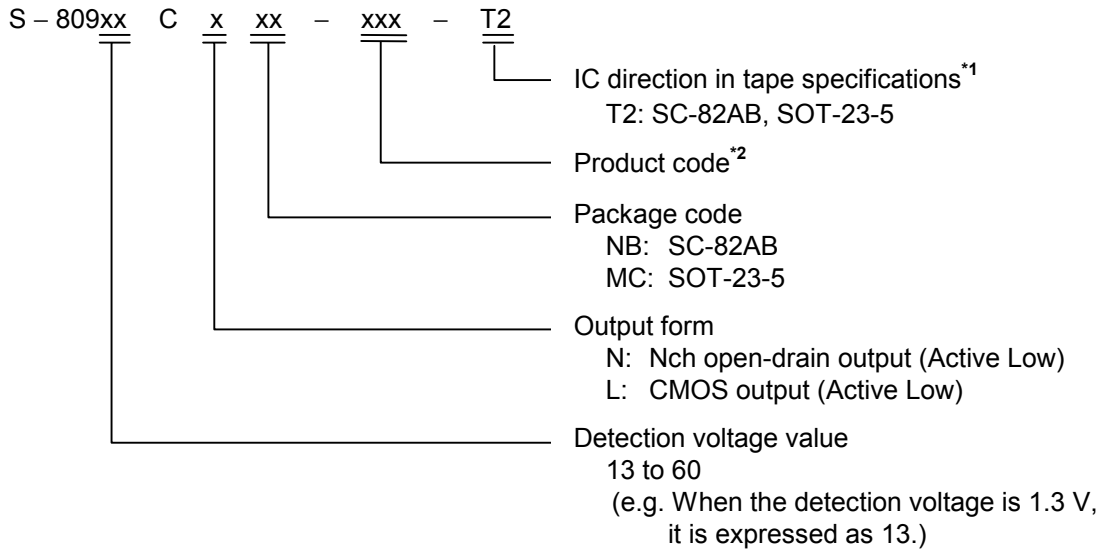

*1. Refer to the taping specifications at the end of this book. T2 is the standard.

*2. Refer to the **Table 1 to 2** in the "2. **Product Name List**"

1-2. SNT-4A package

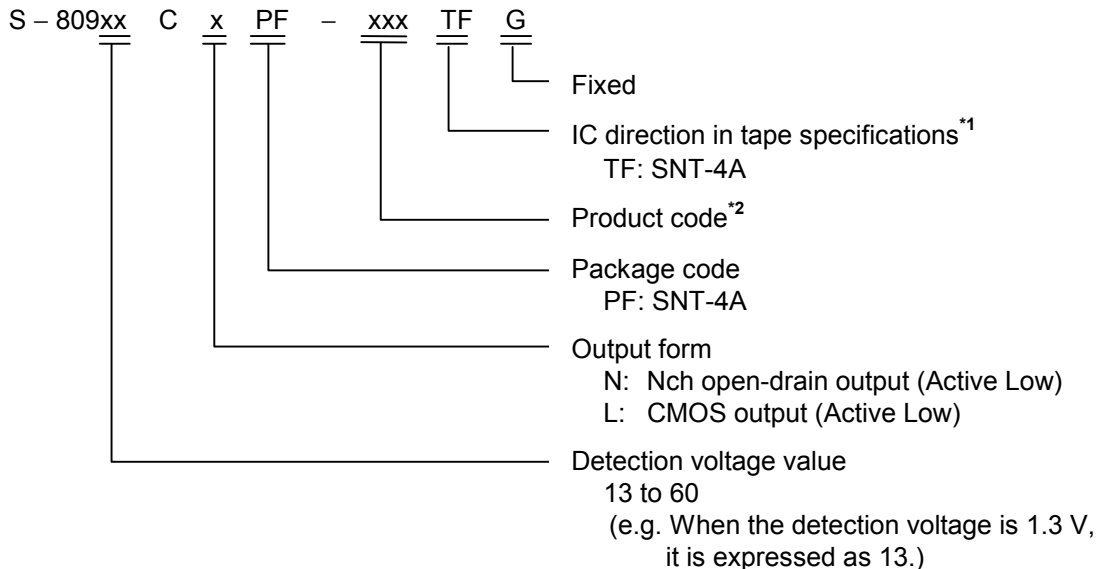

*1. Refer to the taping specifications at the end of this book. TF is the standard.

*2. Refer to the **Table 1 to 2** in the "2. **Product Name List**"

ULTRA-SMALL PACKAGE BUILT-IN DELAY CIRCUIT HIGH PRECISION VOLTAGE DETECTOR
S-809xxC Series

Rev.2.1_00

2. Product Name List

2-1. Nch Open-drain Output Products

Table 1 (1/2)

Detection voltage range	Hysteresis width (Typ.)	SC-82AB	SOT-23-5	SNT-4A
1.3 V ±2.0 %	0.065 V	S-80913CNNB-G8H-T2	S-80913CNMC-G8H-T2	S-80913CNPF-G8HTFG
1.4 V ±2.0 %	0.070 V	S-80914CNNB-G8J-T2	S-80914CNMC-G8J-T2	S-80914CNPF-G8JTFG
1.5 V ±2.0 %	0.075 V	S-80915CNNB-G8K-T2	S-80915CNMC-G8K-T2	S-80915CNPF-G8KTFG
1.6 V ±2.0 %	0.080 V	S-80916CNNB-G8L-T2	S-80916CNMC-G8L-T2	S-80916CNPF-G8LTFG
1.7 V ±2.0 %	0.085 V	S-80917CNNB-G8M-T2	S-80917CNMC-G8M-T2	S-80917CNPF-G8MTFG
1.8 V ±2.0 %	0.090 V	S-80918CNNB-G8N-T2	S-80918CNMC-G8N-T2	S-80918CNPF-G8NTFG
1.9 V ±2.0 %	0.095 V	S-80919CNNB-G8P-T2	S-80919CNMC-G8P-T2	S-80919CNPF-G8PTFG
2.0 V ±2.0 %	0.100 V	S-80920CNNB-G8Q-T2	S-80920CNMC-G8Q-T2	S-80920CNPF-G8QTFG
2.1 V ±2.0 %	0.105 V	S-80921CNNB-G8R-T2	S-80921CNMC-G8R-T2	S-80921CNPF-G8RTFG
2.2 V ±2.0 %	0.110 V	S-80922CNNB-G8S-T2	S-80922CNMC-G8S-T2	S-80922CNPF-G8STFG
2.3 V ±2.0 %	0.115 V	S-80923CNNB-G8T-T2	S-80923CNMC-G8T-T2	S-80923CNPF-G8TTFG
2.4 V ±2.0 %	0.120 V	S-80924CNNB-G8U-T2	S-80924CNMC-G8U-T2	S-80924CNPF-G8UTFG
2.5 V ±2.0 %	0.125 V	S-80925CNNB-G8V-T2	S-80925CNMC-G8V-T2	S-80925CNPF-G8VTFG
2.6 V ±2.0 %	0.130 V	S-80926CNNB-G8W-T2	S-80926CNMC-G8W-T2	S-80926CNPF-G8WTFG
2.7 V ±2.0 %	0.135 V	S-80927CNNB-G8X-T2	S-80927CNMC-G8X-T2	S-80927CNPF-G8XTFG
2.8 V ±2.0 %	0.140 V	S-80928CNNB-G8Y-T2	S-80928CNMC-G8Y-T2	S-80928CNPF-G8YTFG
2.9 V ±2.0 %	0.145 V	S-80929CNNB-G8Z-T2	S-80929CNMC-G8Z-T2	S-80929CNPF-G8ZTFG
3.0 V ±2.0 %	0.150 V	S-80930CNNB-G80-T2	S-80930CNMC-G80-T2	S-80930CNPF-G80TFG
3.1 V ±2.0 %	0.155 V	S-80931CNNB-G81-T2	S-80931CNMC-G81-T2	S-80931CNPF-G81TFG
3.2 V ±2.0 %	0.160 V	S-80932CNNB-G82-T2	S-80932CNMC-G82-T2	S-80932CNPF-G82TFG
3.3 V ±2.0 %	0.165 V	S-80933CNNB-G83-T2	S-80933CNMC-G83-T2	S-80933CNPF-G83TFG
3.4 V ±2.0 %	0.170 V	S-80934CNNB-G84-T2	S-80934CNMC-G84-T2	S-80934CNPF-G84TFG
3.5 V ±2.0 %	0.175 V	S-80935CNNB-G85-T2	S-80935CNMC-G85-T2	S-80935CNPF-G85TFG
3.6 V ±2.0 %	0.180 V	S-80936CNNB-G86-T2	S-80936CNMC-G86-T2	S-80936CNPF-G86TFG
3.7 V ±2.0 %	0.185 V	S-80937CNNB-G87-T2	S-80937CNMC-G87-T2	S-80937CNPF-G87TFG
3.8 V ±2.0 %	0.190 V	S-80938CNNB-G88-T2	S-80938CNMC-G88-T2	S-80938CNPF-G88TFG
3.9 V ±2.0 %	0.195 V	S-80939CNNB-G89-T2	S-80939CNMC-G89-T2	S-80939CNPF-G89TFG
4.0 V ±2.0 %	0.200 V	S-80940CNNB-G9A-T2	S-80940CNMC-G9A-T2	S-80940CNPF-G9ATFG
4.1 V ±2.0 %	0.205 V	S-80941CNNB-G9B-T2	S-80941CNMC-G9B-T2	S-80941CNPF-G9BTFG
4.2 V ±2.0 %	0.210 V	S-80942CNNB-G9C-T2	S-80942CNMC-G9C-T2	S-80942CNPF-G9CTFG
4.3 V ±2.0 %	0.215 V	S-80943CNNB-G9D-T2	S-80943CNMC-G9D-T2	S-80943CNPF-G9DTFG
4.4 V ±2.0 %	0.220 V	S-80944CNNB-G9E-T2	S-80944CNMC-G9E-T2	S-80944CNPF-G9ETFG
4.5 V ±2.0 %	0.225 V	S-80945CNNB-G9F-T2	S-80945CNMC-G9F-T2	S-80945CNPF-G9FTFG
4.6 V ±2.0 %	0.230 V	S-80946CNNB-G9G-T2	S-80946CNMC-G9G-T2	S-80946CNPF-G9GTFG
4.7 V ±2.0 %	0.235 V	S-80947CNNB-G9H-T2	S-80947CNMC-G9H-T2	S-80947CNPF-G9HTFG
4.8 V ±2.0 %	0.240 V	S-80948CNNB-G9J-T2	S-80948CNMC-G9J-T2	S-80948CNPF-G9JTFG
4.9 V ±2.0 %	0.245 V	S-80949CNNB-G9K-T2	S-80949CNMC-G9K-T2	S-80949CNPF-G9KTFG
5.0 V ±2.0 %	0.250 V	S-80950CNNB-G9L-T2	S-80950CNMC-G9L-T2	S-80950CNPF-G9LTFG
5.1 V ±2.0 %	0.255 V	S-80951CNNB-G9M-T2	S-80951CNMC-G9M-T2	S-80951CNPF-G9MTFG
5.2 V ±2.0 %	0.260 V	S-80952CNNB-G9N-T2	S-80952CNMC-G9N-T2	S-80952CNPF-G9NTFG
5.3 V ±2.0 %	0.265 V	S-80953CNNB-G9P-T2	S-80953CNMC-G9P-T2	S-80953CNPF-G9PTFG
5.4 V ±2.0 %	0.270 V	S-80954CNNB-G9Q-T2	S-80954CNMC-G9Q-T2	S-80954CNPF-G9QTFG
5.5 V ±2.0 %	0.275 V	S-80955CNNB-G9R-T2	S-80955CNMC-G9R-T2	S-80955CNPF-G9RTFG
5.6 V ±2.0 %	0.280 V	S-80956CNNB-G9S-T2	S-80956CNMC-G9S-T2	S-80956CNPF-G9STFG
5.7V ±2.0 %	0.285 V	S-80957CNNB-G9T-T2	S-80957CNMC-G9T-T2	S-80957CNPF-G9TTFG
5.8 V ±2.0 %	0.290 V	S-80958CNNB-G9U-T2	S-80958CNMC-G9U-T2	S-80958CNPF-G9UTFG
5.9 V ±2.0 %	0.295 V	S-80959CNNB-G9V-T2	S-80959CNMC-G9V-T2	S-80959CNPF-G9VTFG
6.0 V ±2.0 %	0.300 V	S-80960CNNB-G9W-T2	S-80960CNMC-G9W-T2	S-80960CNPF-G9WTFG

ULTRA-SMALL PACKAGE BUILT-IN DELAY CIRCUIT HIGH-PRECISION VOLTAGE DETECTOR

Rev.2.1_00

S-809xxC Series

2-2. CMOS Output Products

Table 2 (1/2)

Detection voltage range	Hysteresis width (Typ.)	SC-82AB	SOT-23-5	SNT-4A
1.3 V ±2.0 %	0.065 V	S-80913CLNB-G6H-T2	S-80913CLMC-G6H-T2	S-80913CLPF-G6HTFG
1.4 V ±2.0 %	0.070 V	S-80914CLNB-G6J-T2	S-80914CLMC-G6J-T2	S-80914CLPF-G6JTFG
1.5 V ±2.0 %	0.075 V	S-80915CLNB-G6K-T2	S-80915CLMC-G6K-T2	S-80915CLPF-G6KTFG
1.6 V ±2.0 %	0.080 V	S-80916CLNB-G6L-T2	S-80916CLMC-G6L-T2	S-80916CLPF-G6LTFG
1.7 V ±2.0 %	0.085 V	S-80917CLNB-G6M-T2	S-80917CLMC-G6M-T2	S-80917CLPF-G6MTFG
1.8 V ±2.0 %	0.090 V	S-80918CLNB-G6N-T2	S-80918CLMC-G6N-T2	S-80918CLPF-G6NTFG
1.9 V ±2.0 %	0.095 V	S-80919CLNB-G6P-T2	S-80919CLMC-G6P-T2	S-80919CLPF-G6PTFG
2.0 V ±2.0 %	0.100 V	S-80920CLNB-G6Q-T2	S-80920CLMC-G6Q-T2	S-80920CLPF-G6QTFG
2.1 V ±2.0 %	0.105 V	S-80921CLNB-G6R-T2	S-80921CLMC-G6R-T2	S-80921CLPF-G6RTFG
2.2 V ±2.0 %	0.110 V	S-80922CLNB-G6S-T2	S-80922CLMC-G6S-T2	S-80922CLPF-G6STFG
2.3 V ±2.0 %	0.115 V	S-80923CLNB-G6T-T2	S-80923CLMC-G6T-T2	S-80923CLPF-G6TTFG
2.4 V ±2.0 %	0.120 V	S-80924CLNB-G6U-T2	S-80924CLMC-G6U-T2	S-80924CLPF-G6UTFG
2.5 V ±2.0 %	0.125 V	S-80925CLNB-G6V-T2	S-80925CLMC-G6V-T2	S-80925CLPF-G6VTFG
2.6 V ±2.0 %	0.130 V	S-80926CLNB-G6W-T2	S-80926CLMC-G6W-T2	S-80926CLPF-G6WTFG
2.7 V ±2.0 %	0.135 V	S-80927CLNB-G6X-T2	S-80927CLMC-G6X-T2	S-80927CLPF-G6XTFG
2.8 V ±2.0 %	0.140 V	S-80928CLNB-G6Y-T2	S-80928CLMC-G6Y-T2	S-80928CLPF-G6YTFG
2.9 V ±2.0 %	0.145 V	S-80929CLNB-G6Z-T2	S-80929CLMC-G6Z-T2	S-80929CLPF-G6ZTFG
3.0 V ±2.0 %	0.150 V	S-80930CLNB-G60-T2	S-80930CLMC-G60-T2	S-80930CLPF-G60TFG
3.1 V ±2.0 %	0.155 V	S-80931CLNB-G61-T2	S-80931CLMC-G61-T2	S-80931CLPF-G61TFG
3.2 V ±2.0 %	0.160 V	S-80932CLNB-G62-T2	S-80932CLMC-G62-T2	S-80932CLPF-G62TFG
3.3 V ±2.0 %	0.165 V	S-80933CLNB-G63-T2	S-80933CLMC-G63-T2	S-80933CLPF-G63TFG
3.4 V ±2.0 %	0.170 V	S-80934CLNB-G64-T2	S-80934CLMC-G64-T2	S-80934CLPF-G64TFG
3.5 V ±2.0 %	0.175 V	S-80935CLNB-G65-T2	S-80935CLMC-G65-T2	S-80935CLPF-G65TFG
3.6 V ±2.0 %	0.180 V	S-80936CLNB-G66-T2	S-80936CLMC-G66-T2	S-80936CLPF-G66TFG
3.7 V ±2.0 %	0.185 V	S-80937CLNB-G67-T2	S-80937CLMC-G67-T2	S-80937CLPF-G67TFG
3.8 V ±2.0 %	0.190 V	S-80938CLNB-G68-T2	S-80938CLMC-G68-T2	S-80938CLPF-G68TFG
3.9 V ±2.0 %	0.195 V	S-80939CLNB-G69-T2	S-80939CLMC-G69-T2	S-80939CLPF-G69TFG
4.0 V ±2.0 %	0.200 V	S-80940CLNB-G7A-T2	S-80940CLMC-G7A-T2	S-80940CLPF-G7ATFG
4.1 V ±2.0 %	0.205 V	S-80941CLNB-G7B-T2	S-80941CLMC-G7B-T2	S-80941CLPF-G7BTFG
4.2 V ±2.0 %	0.210 V	S-80942CLNB-G7C-T2	S-80942CLMC-G7C-T2	S-80942CLPF-G7CTFG
4.3 V ±2.0 %	0.215 V	S-80943CLNB-G7D-T2	S-80943CLMC-G7D-T2	S-80943CLPF-G7DTFG
4.4 V ±2.0 %	0.220 V	S-80944CLNB-G7E-T2	S-80944CLMC-G7E-T2	S-80944CLPF-G7ETFG
4.5 V ±2.0 %	0.225 V	S-80945CLNB-G7F-T2	S-80945CLMC-G7F-T2	S-80945CLPF-G7FTFG
4.6 V ±2.0 %	0.230 V	S-80946CLNB-G7G-T2	S-80946CLMC-G7G-T2	S-80946CLPF-G7GTFG
4.7 V ±2.0 %	0.235 V	S-80947CLNB-G7H-T2	S-80947CLMC-G7H-T2	S-80947CLPF-G7HTFG
4.8 V ±2.0 %	0.240 V	S-80948CLNB-G7J-T2	S-80948CLMC-G7J-T2	S-80948CLPF-G7JTFG
4.9 V ±2.0 %	0.245 V	S-80949CLNB-G7K-T2	S-80949CLMC-G7K-T2	S-80949CLPF-G7KTFG
5.0 V ±2.0 %	0.250 V	S-80950CLNB-G7L-T2	S-80950CLMC-G7L-T2	S-80950CLPF-G7LTFG
5.1 V ±2.0 %	0.255 V	S-80951CLNB-G7M-T2	S-80951CLMC-G7M-T2	S-80951CLPF-G7MTFG
5.2 V ±2.0 %	0.260 V	S-80952CLNB-G7N-T2	S-80952CLMC-G7N-T2	S-80952CLPF-G7NTFG
5.3 V ±2.0 %	0.265 V	S-80953CLNB-G7P-T2	S-80953CLMC-G7P-T2	S-80953CLPF-G7PTFG
5.4 V ±2.0 %	0.270 V	S-80954CLNB-G7Q-T2	S-80954CLMC-G7Q-T2	S-80954CLPF-G7QTFG
5.5 V ±2.0 %	0.275 V	S-80955CLNB-G7R-T2	S-80955CLMC-G7R-T2	S-80955CLPF-G7RTFG
5.6 V ±2.0 %	0.280 V	S-80956CLNB-G7S-T2	S-80956CLMC-G7S-T2	S-80956CLPF-G7STFG
5.7 V ±2.0 %	0.285 V	S-80957CLNB-G7T-T2	S-80957CLMC-G7T-T2	S-80957CLPF-G7TTFG
5.8 V ±2.0 %	0.290 V	S-80958CLNB-G7U-T2	S-80958CLMC-G7U-T2	S-80958CLPF-G7UTFG
5.9 V ±2.0 %	0.295 V	S-80959CLNB-G7V-T2	S-80959CLMC-G7V-T2	S-80959CLPF-G7VTFG
6.0 V ±2.0 %	0.300 V	S-80960CLNB-G7W-T2	S-80960CLMC-G7W-T2	S-80960CLPF-G7WTFG

■ Pin Configurations

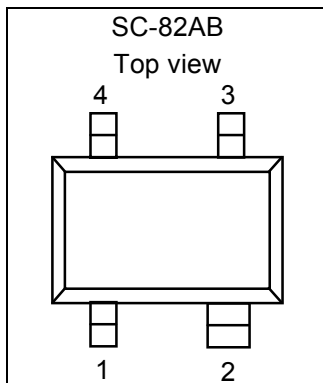

Figure 3

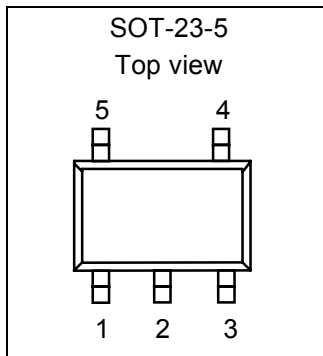

Figure 4

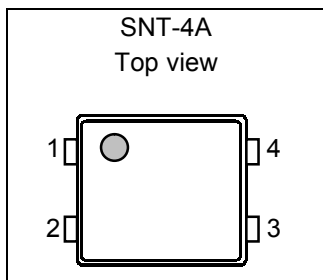

Figure 5

Table 3

Pin No.	Pin name	Pin description
1	VSS	GND pin
2	VDD	Voltage input pin
3	CD	Connection pin for delay capacitor
4	OUT	Voltage detection output pin

Table 4

Pin No.	Pin name	Pin description
1	OUT	Voltage detection output pin
2	VDD	Voltage input pin
3	VSS	GND pin
4	NC ^{*1}	No connection
5	CD	Connection pin for delay capacitor

*1. The NC pin is electrically open.
 The NC pin can be connected to VDD or VSS.

Table 5

Pin No.	Pin name	Pin description
1	VSS	GND pin
2	OUT	Voltage detection output pin
3	CD	Connection pin for delay capacitor
4	VDD	Voltage input pin

■ Absolute Maximum Ratings

Table 6

(Ta=25°C unless otherwise specified)

Item	Symbol	Absolute maximum ratings	Unit
Power supply voltage	$V_{DD}-V_{SS}$	12	V
CD pin input voltage	V_{CD}	$V_{SS}-0.3$ to $V_{DD}+0.3$	
Output voltage	V_{OUT}	$V_{SS}-0.3$ to $V_{SS}+12$	
Nch open-drain output products		$V_{SS}-0.3$ to $V_{DD}+0.3$	
CMOS output products			
Output current	I_{OUT}	50	mA
Power dissipation	P_D	SC-82AB	mW
		SOT-23-5	
		SNT-4A	
Operating ambient temperature	T_{opr}	-40 to +85	°C
Storage temperature	T_{stg}	-40 to +125	

Caution The absolute maximum ratings are rated values exceeding which the product could suffer physical damage. These values must therefore not be exceeded under any conditions.

■ Electrical Characteristics

1. Nch Open-drain Output Products

Table 7

(Ta=25°C unless otherwise specified)

Item	Symbol	Condition	Min.	Typ.	Max.	Unit	Test circuit		
Detection voltage *1	$-V_{DET}$	—	$-V_{DET(S)} \times 0.98$	$-V_{DET(S)}$	$-V_{DET(S)} \times 1.02$	V	1		
Hysteresis width	V_{HYS}	S-80913 to 14	$-V_{DET} \times 0.03$	$-V_{DET} \times 0.05$	$-V_{DET} \times 0.08$				
		S-80915 to 60	$-V_{DET} \times 0.03$	$-V_{DET} \times 0.05$	$-V_{DET} \times 0.07$				
Current consumption	I_{SS}	$V_{DD}=2.0$ V	S-80913 to 14	—	1.0	2.5	μ A	2	
		$V_{DD}=3.5$ V	S-80915 to 26	—	1.1	2.8			
		$V_{DD}=4.5$ V	S-80927 to 39	—	1.2	3.0			
		$V_{DD}=6.0$ V	S-80940 to 54	—	1.3	3.3			
		$V_{DD}=7.5$ V	S-80955 to 60	—	1.4	3.5			
Operating voltage	V_{DD}	—	0.7	—	10.0	V	1		
Output current	I_{OUT}	Output transistor, Nch, $V_{DS}=0.5$ V	$V_{DD}=0.95$ V	S-80913 to 14	0.23	0.64	—	mA	3
			$V_{DD}=1.2$ V	S-80915 to 60	0.59	1.36	—		
			$V_{DD}=2.4$ V	S-80927 to 60	2.88	4.98	—		
Leakage current	I_{LEAK}	Output transistor, Nch, $V_{DS}=10.0$ V, $V_{DD}=10.0$ V	—	—	0.1	μ A			
Delay time	t_D	$C_D=4.7$ nF	$V_{DD}=2.0$ V	S-80913 to 14	2.7	3.6	4.5	ms	4
			$V_{DD}=3.5$ V	S-80915 to 26	20	27	34		
			$V_{DD}=4.5$ V	S-80927 to 39					
			$V_{DD}=6.0$ V	S-80940 to 54					
			$V_{DD}=7.5$ V	S-80955 to 60					
Detection voltage temperature coefficient *2	$\frac{\Delta - V_{DET}}{\Delta Ta \bullet -V_{DET}}$	Ta=−40°C to +85°C	—	± 100	± 350	ppm/°C	1		

*1. $-V_{DET}$: Actual detection voltage, $-V_{DET(S)}$: Specified detection voltage (The center value of detection voltage range in Table 1.)

*2. The temperature change ratio in the detection voltage [mV/°C] is calculated by using the following equation.

$$\frac{\Delta - V_{DET}}{\Delta Ta} [mV/^\circ C]^*1 = -V_{DET}(Typ.) [V]^*2 \times \frac{\Delta - V_{DET}}{\Delta Ta \bullet -V_{DET}} [ppm/^\circ C]^*3 \div 1000$$

*1. Temperature change ratio of the detection voltage

*2. Specified detection voltage

*3. Detection voltage temperature coefficient

2. CMOS Output Products

Table 8

(Ta=25°C unless otherwise specified)

Item	Symbol	Condition	Min.	Typ.	Max.	Unit	Test circuit	
Detection voltage*1	-V _{DET}	—	-V _{DET(S)} ×0.98	-V _{DET(S)}	-V _{DET(S)} ×1.02	V	1	
Hysteresis width	V _{HYS}	S-80913 to 14	-V _{DET} ×0.03	-V _{DET} ×0.05	-V _{DET} ×0.08			
		S-80915 to 60	-V _{DET} ×0.03	-V _{DET} ×0.05	-V _{DET} ×0.07			
Current consumption	I _{SS}	V _{DD} =2.0 V	—	1.0	2.5	μA	2	
		V _{DD} =3.5 V	—	1.1	2.8			
		V _{DD} =4.5 V	—	1.2	3.0			
		V _{DD} =6.0 V	—	1.3	3.3			
		V _{DD} =7.5 V	—	1.4	3.5			
Operating voltage	V _{DD}	—	0.7	—	10.0	V	1	
Output current	I _{OUT}	Output transistor, Nch, V _{DS} =0.5 V	V _{DD} =0.95 V S-80913 to 14	0.23	0.64	—	mA	3
			V _{DD} =1.2 V S-80915 to 60	0.59	1.36	—		
			V _{DD} =2.4 V S-80927 to 60	2.88	4.98	—		
		Output transistor, Pch, V _{DS} =0.5 V	V _{DD} =4.8 V S-80913 to 39	1.43	2.39	—	5	
			V _{DD} =6.0 V S-80940 to 54	1.68	2.78	—		
			V _{DD} =8.4 V S-80955 to 60	2.08	3.42	—		
Delay time	t _D	C _D =4.7 nF	V _{DD} =2.0 V S-80913 to 14	2.7	3.6	4.5	ms	4
			V _{DD} =3.5 V S-80915 to 26	18	24	30		
			V _{DD} =4.5 V S-80927 to 39					
			V _{DD} =6.0 V S-80940 to 54					
			V _{DD} =7.5 V S-80955 to 60					
Detection voltage temperature coefficient*2	$\frac{\Delta - V_{DET}}{\Delta Ta \bullet -V_{DET}}$	Ta=-40°C to +85°C	—	±100	±350	ppm/°C	1	

*1. -V_{DET}: Actual detection voltage, -V_{DET(S)}: Specified detection voltage (The center value of detection voltage range in **Table 2.**)

*2. The temperature change ratio in the detection voltage [mV/°C] is calculated by using the following equation.

$$\frac{\Delta - V_{DET}}{\Delta Ta} [mV/°C]^*1 = -V_{DET} (Typ.) [V]^*2 \times \frac{\Delta - V_{DET}}{\Delta Ta \bullet -V_{DET}} [ppm/°C]^*3 \div 1000$$

*1. Temperature change ratio of the detection voltage

*2. Specified detection voltage

*3. Detection voltage temperature coefficient

■ Test Circuits

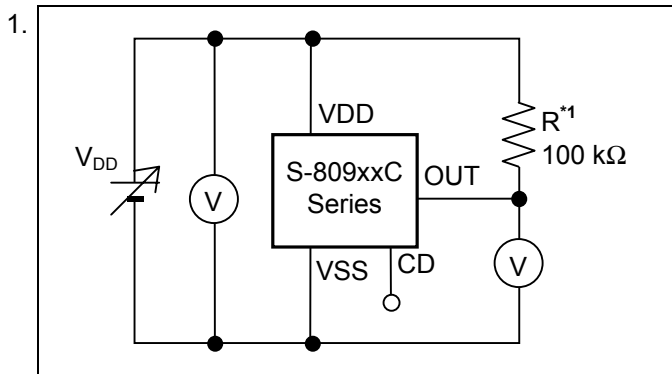

*1. R is unnecessary for CMOS output products.

Figure 6

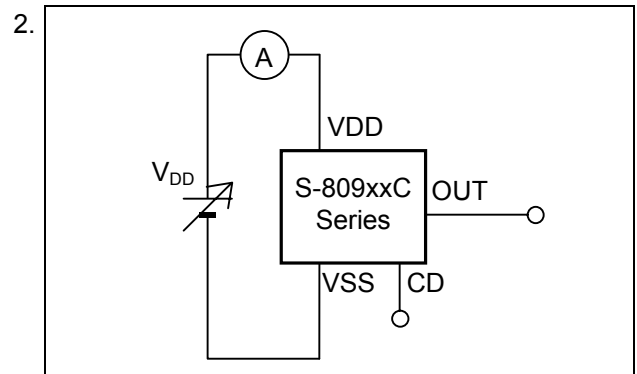

Figure 7

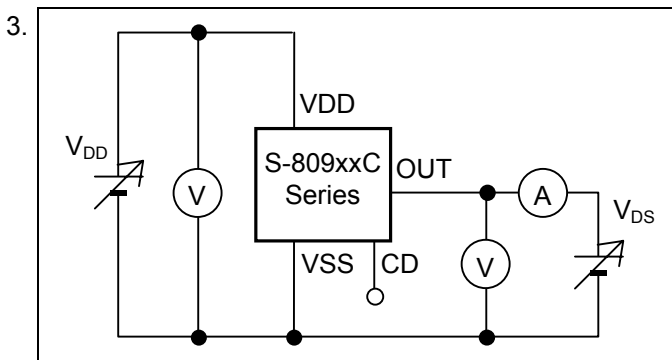
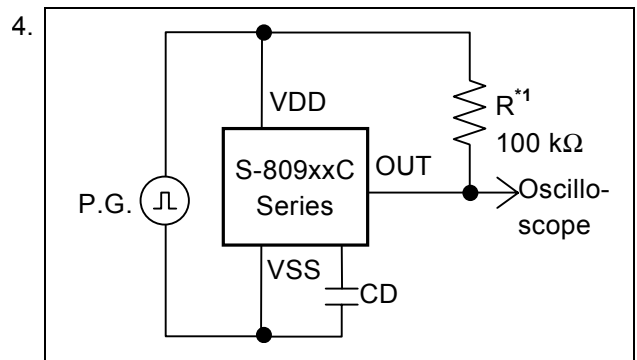

Figure 8



*1. R is unnecessary for CMOS output products.

Figure 9

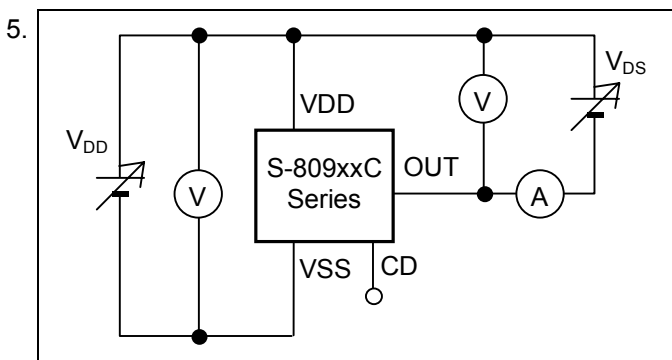

Figure 10

■ Timing Chart

1. Nch Open-drain Output Products

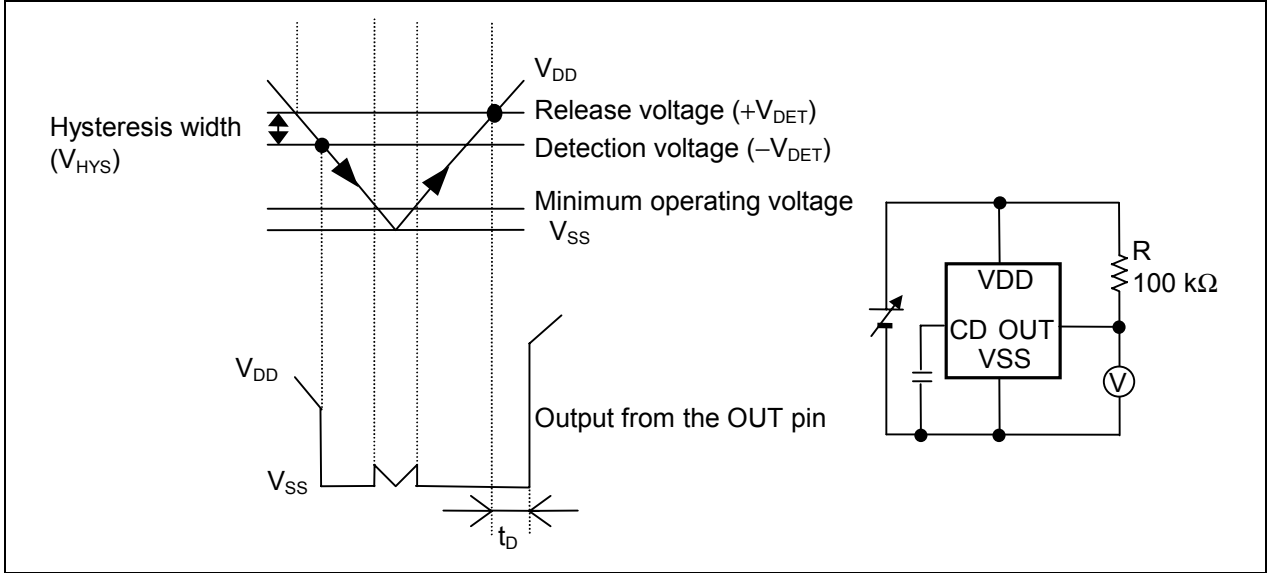
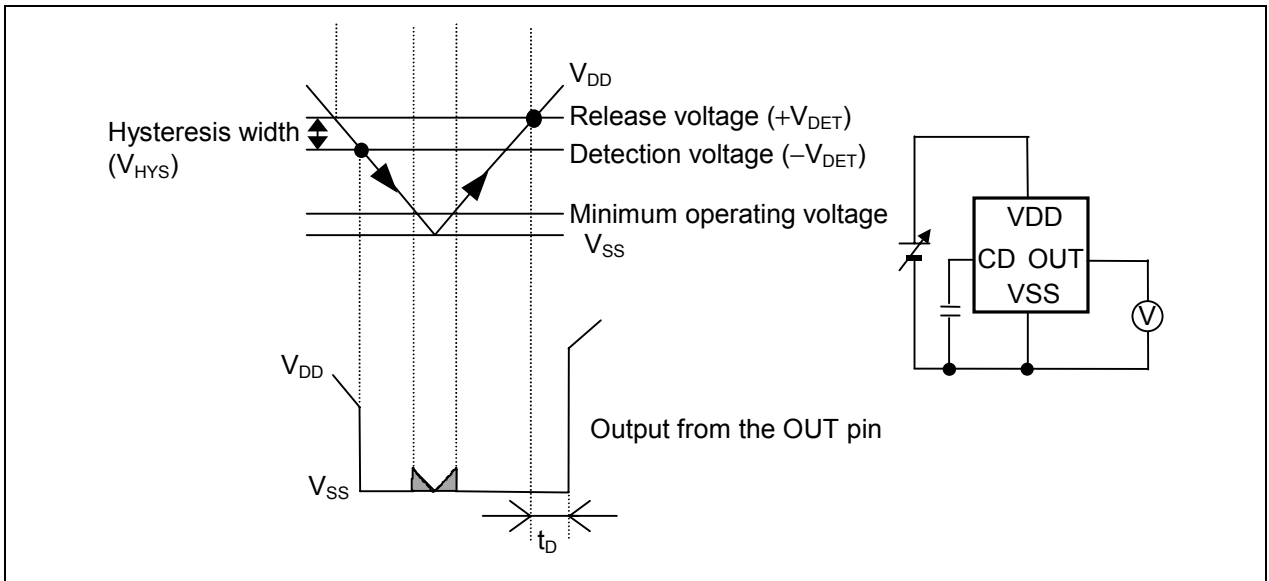

Figure 11

2. CMOS Output Products



Remark For values of V_{DD} less than minimum operating voltage, values of OUT pin output is free of the shaded region.

Figure 12

■ Operation

1. Basic Operation: CMOS Output (Active Low)

- 1-1. When the power supply voltage (V_{DD}) is higher than the release voltage ($+V_{DET}$), the Nch transistor is OFF and the Pch transistor is ON to provide V_{DD} (high) at the output. Since the Nch transistor N1 in **Figure 13** is OFF, the comparator input voltage is $\frac{(R_B + R_C) \cdot V_{DD}}{R_A + R_B + R_C}$.
- 1-2. When the V_{DD} goes below $+V_{DET}$, the output provides the V_{DD} level, as long as the V_{DD} remains above the detection voltage $-V_{DET}$. When the V_{DD} falls below $-V_{DET}$ (point A in **Figure 14**), the Nch transistor becomes ON, the Pch transistor becomes OFF, and the V_{SS} level appears at the output. At this time the Nch transistor N1 in **Figure 14** becomes ON, the comparator input voltage is changed to $\frac{R_B \cdot V_{DD}}{R_A + R_B}$.
- 1-3. When the V_{DD} falls below the minimum operating voltage, the output becomes undefined, or goes to the V_{DD} when the output is pulled up to the V_{DD} .
- 1-4. The V_{SS} level appears when the V_{DD} rises above the minimum operating voltage. The V_{SS} level still appears even when the V_{DD} surpasses $-V_{DET}$, as long as it does not exceed the release voltage $+V_{DET}$.
- 1-5. When V_{DD} rises above $+V_{DET}$ (point B in **Figure 14**), the Nch transistor becomes OFF, and the Pch transistor becomes ON, and V_{DD} appears at the output after the delay time (t_D) counted by the delay circuit.

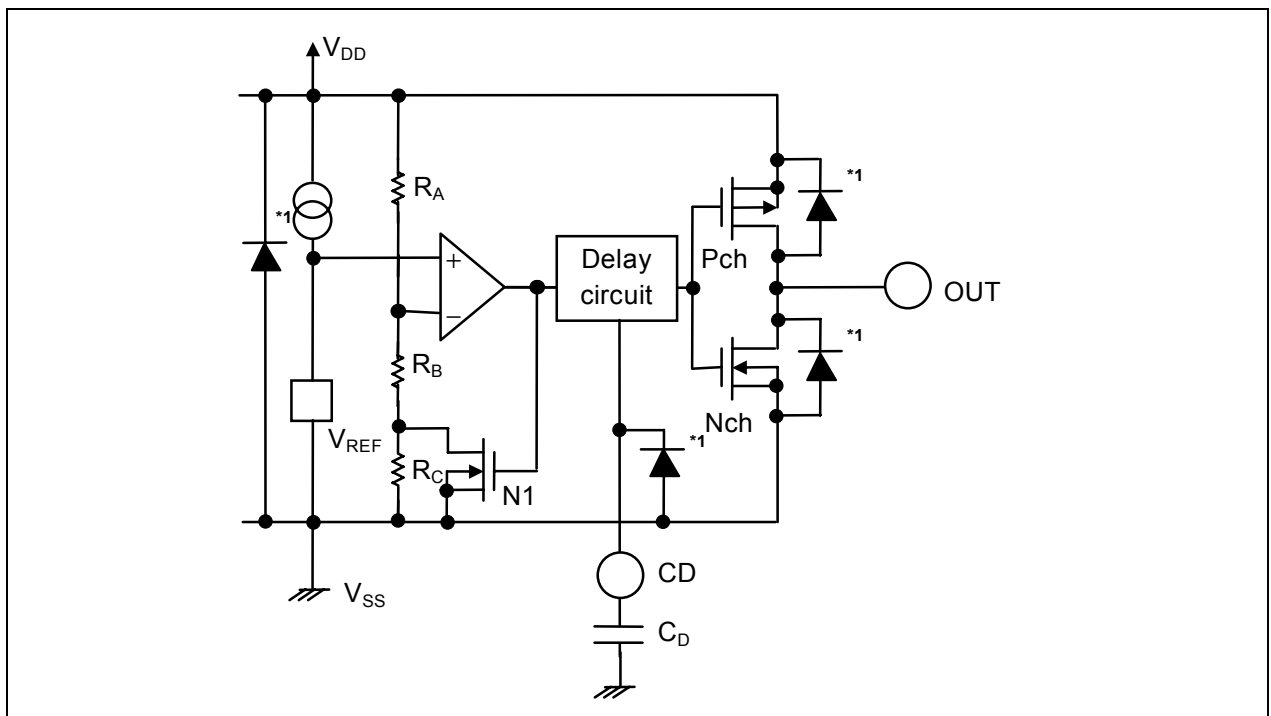

*1. Parasitic diode

Figure 13 Operation 1

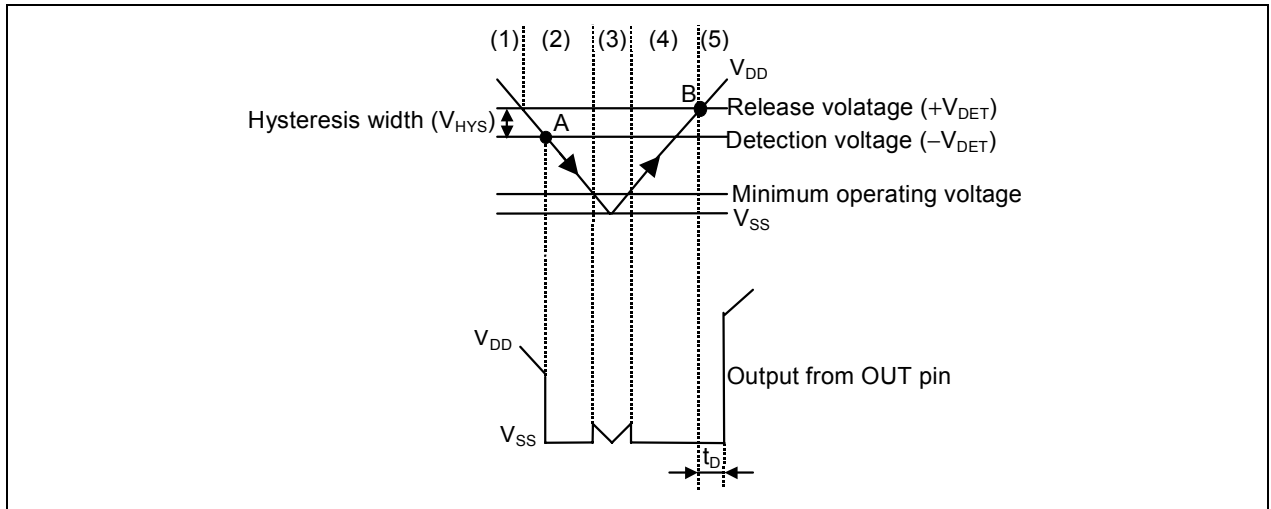

Figure 14 Operation 2

2. Delay Circuit

The delay circuit delays the output signal from the time at which the power voltage (V_{DD}) exceeds the release voltage ($+V_{DET}$) when V_{DD} is turned on. The output signal is not delayed when the V_{DD} goes below the detection voltage ($-V_{DET}$) (Refer to **Figure 14**). The delay time (t_D) is determined by the time constant of the built-in constant current (approx. 100 nA) and the attached external capacitor (C_D), and calculated from the following equation.

$$t_D (\text{ms}) = \text{Delay coefficient} \times C_D (\text{nF})$$

Delay coefficient: (25°C)

Detection voltage $-V_{DET} \leq 1.4 \text{ V}$ Min. 0.57, Typ. 0.77, Max. 0.96

Detection voltage $-V_{DET} \geq 1.5 \text{ V}$

Nch open-drain output products: Min. 4.3, Typ. 5.7, Max. 7.2

CMOS output products: Min. 3.8, Typ. 5.1, Max. 6.4

Caution 1. When the CD pin is open, a double pulse shown in **Figure 15** may appear at release. To avoid the double pulse, attach 20 pF or larger capacitor to the CD pin. Do not apply voltage to the CD pin.

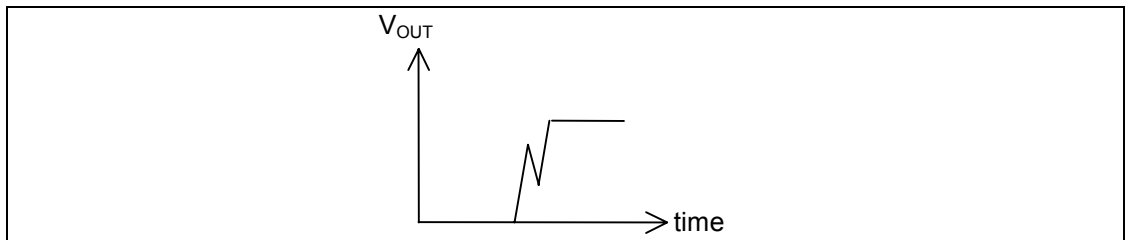

Figure 15

2. Print circuit board layout should be made in such a way that no current flows into or flows from the CD pin since the impedance of the CD pin is high, otherwise correct delay time cannot be provided.
3. There is no limit for the capacitance of the external capacitor (C_D) as long as the leakage current of the capacitor can be ignored against the built-in constant current value. Leakage current causes deviation in delay time. When the leakage current is larger than the built-in constant current, no release takes place.

3. Other characteristics

3-1. Temperature Characteristic of Detection Voltage

The shaded area in **Figure 16** shows the temperature characteristics of the detection voltage.

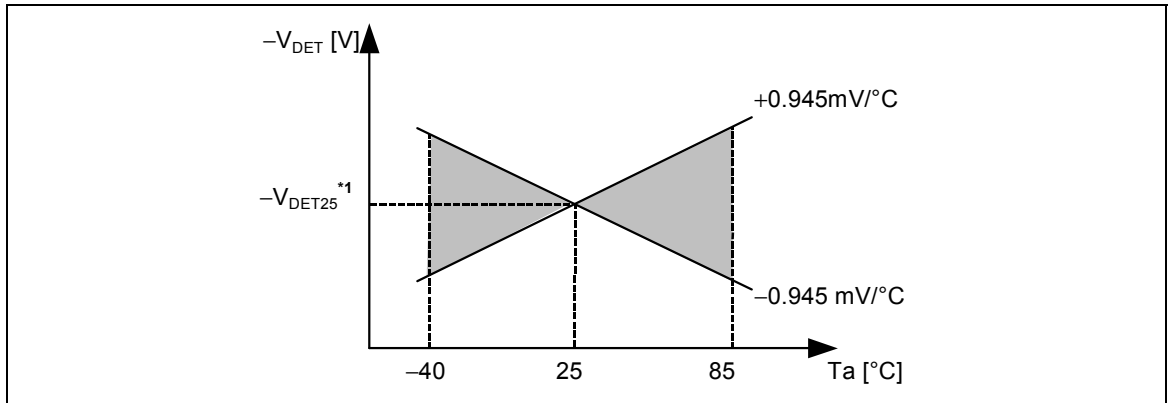

*1. $-V_{DET25}$ is an actual detection voltage value at 25 °C.

Figure 16 Temperature Characteristic of Detection Voltage (Example for S-80927C)

3-2. Temperature Characteristics of Release Voltage

The temperature coefficient $\frac{\Delta + V_{DET}}{\Delta Ta}$ for the release voltage is calculated by the temperature coefficient of the detection voltage $\frac{\Delta - V_{DET}}{\Delta Ta}$ as follows:

$$\frac{\Delta + V_{DET}}{\Delta Ta} = \frac{+V_{DET}}{-V_{DET}} \times \frac{\Delta - V_{DET}}{\Delta Ta}$$

The temperature coefficients for the release voltage and the detection voltage have the same sign consequently.

3-3. Temperature Characteristics of Hysteresis Voltage

The temperature characteristics for the hysteresis voltage is expressed as $\frac{\Delta + V_{DET}}{\Delta Ta} - \frac{\Delta - V_{DET}}{\Delta Ta}$ and is calculated as follows:

$$\frac{\Delta + V_{DET}}{\Delta Ta} - \frac{\Delta - V_{DET}}{\Delta Ta} = \frac{V_{HYS}}{-V_{DET}} \times \frac{\Delta - V_{DET}}{\Delta Ta}$$

■ Standard Circuit

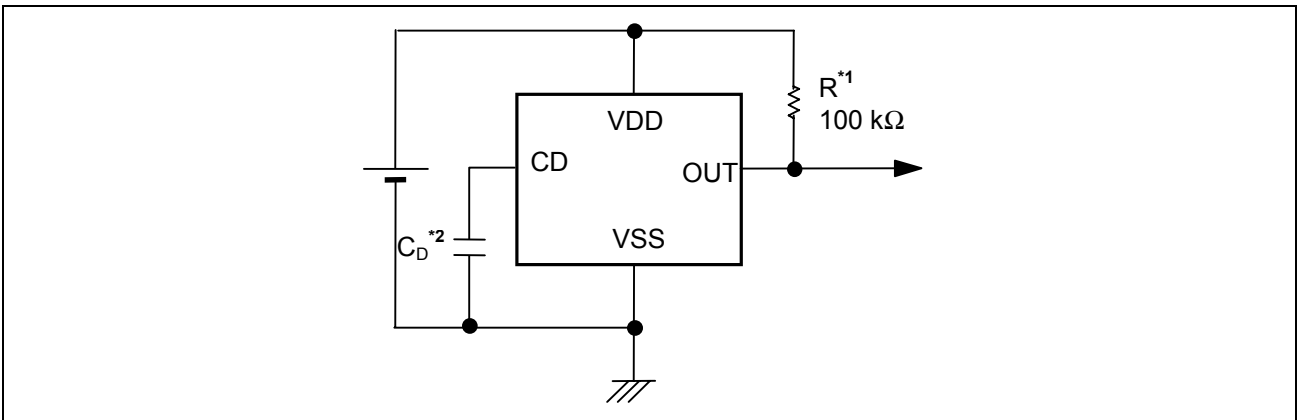

*1. R is unnecessary for CMOS output products.

*2. The delay capacitor (C_D) should be connected directly to the CD pin and to the VSS pin.

Figure 17

Caution The above connection diagram and constant will not guarantees successful operation. Perform through evaluation using the actual application to set the constant.

■ Technical Terms

1. Detection Voltage ($-V_{DET}$), Release Voltage ($+V_{DET}$)

The detection voltage ($-V_{DET}$) is a voltage at which the output turns to low. This detection voltage varies slightly among products of the same specification. The variation of detection voltage between the specified minimum ($-V_{DET}$ Min. and maximum ($-V_{DET}$ Max. is called the detection voltage range (Refer to **Figure 18**).

Example: For the S-80927CN, detection voltage lies in the range of $2.646 \leq (-V_{DET}) \leq 2.754$.
This means that some S-80927CNs have 2.646 V for $-V_{DET}$ and some have 2.754 V.

The release voltage ($+V_{DET}$) is a voltage at which the output turns to high. This release voltage varies slightly among products of the same specification. The variation of release voltage between the specified minimum ($+V_{DET}$ Min. and maximum ($+V_{DET}$ Max. is called the release voltage range (Refer to **Figure 19**). The range is calculated from the actual detection voltage ($-V_{DET}$) of a product and is expressed by $-V_{DET} \times 1.03 \leq +V_{DET} \leq -V_{DET} \times 1.08$ for S-80913 to S-80914, and by $-V_{DET} \times 1.03 \leq +V_{DET} \leq -V_{DET} \times 1.07$ for S-80915 to S-80960.

Example: For the S-80927CN, the release voltage lies in the range of $2.725 \leq (+V_{DET}) \leq 2.947$.
This means that some S-80927CNs have 2.725 V for $+V_{DET}$ and some have 2.947 V.

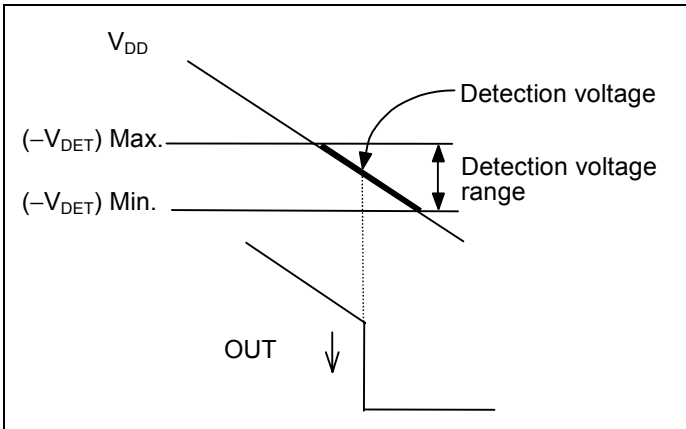

Figure 18 Detection Voltage (CMOS output products)

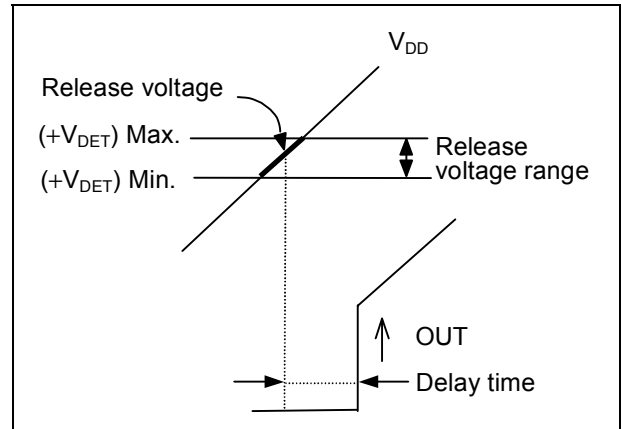

Figure 19 Release Voltage (CMOS output products)

Remark Although the detection voltage and release voltage overlap in the range of 2.725 V to 2.754 V, $+V_{DET}$ is always larger than $-V_{DET}$.

2. Hysteresis Width (V_{HYS})

Hysteresis width is the voltage difference between the detection voltage and the release voltage (The voltage at point B–The voltage at point A= V_{HYS} in **Figure 14**). The existence of the hysteresis width avoids malfunction caused by noise on input signal.

3. Delay Time (t_D)

Delay time is a time internally measured from the instant at which input voltage to the VDD pin exceeds the release voltage ($+V_{DET}$) to the point at which the output of the OUT pin inverts. The delay time changes according to the external capacitor (C_D).

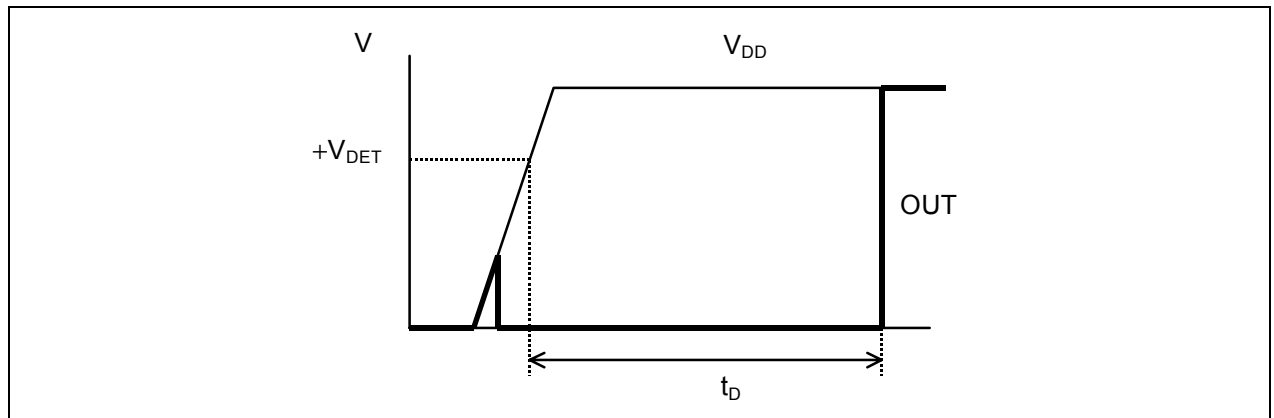

Figure 20

4. Through-type Current

The through-type current refers to the current that flows instantaneously at the time of detection and release of a voltage detector. The through-type current is large in CMOS output products, and small in Nch open-drain output products.

5. Oscillation

In applications where a resistor is connected to the voltage detector input (**Figure 21**), taking a CMOS active low product for example, the through-type current, which is generated when the output goes from low to high (release) causes a voltage drop equal to [through-type current] × [input resistance] across the resistor. When the input voltage drops below the detection voltage ($-V_{DET}$) as a result, the output voltage goes to low level. In this state, the through-type current stops and its resultant voltage drop disappears, and the output goes from low to high. The through-type current again generated, a voltage drop appears, and repeating the process finally induces oscillation.

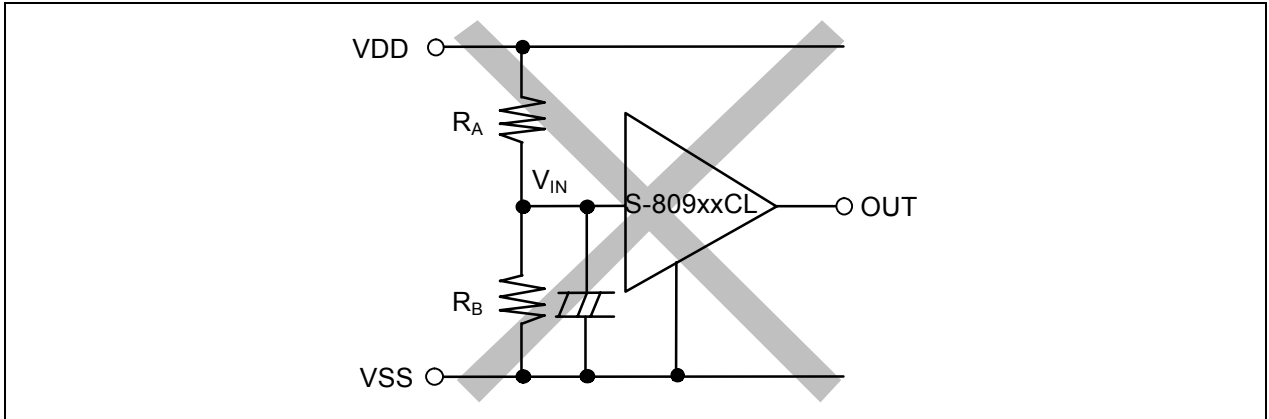

Figure 21 Example for Bad Implementation of Input Voltage Divider (CMOS Output Products)

■ Precautions

- Do not apply an electrostatic discharge to this IC that exceeds the performance ratings of the built-in electrostatic protection circuit.
- In CMOS output products of the S-809xxC series, the through-type current flows at the detection and the release. If the input impedance is high, oscillation may occur due to the voltage drop by the through-type current during releasing.
- When designing for mass production using an application circuit described herein, the product deviation and temperature characteristics should be taken into consideration. SII shall not bear any responsibility for the patents on the circuits described herein.
- SII claims no responsibility for any and all disputes arising out of or in connection with any infringement of the products including this IC upon patents owned by a third party.

■ **Typical Characteristics (Typical Data)**

1. Detection Voltage (V_{DET}) - Temperature (T_a)

S-80913CN

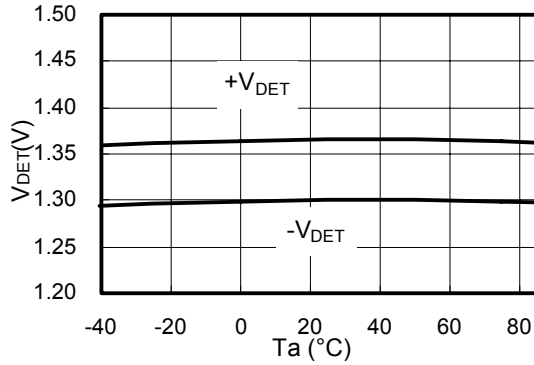

S-80914CN

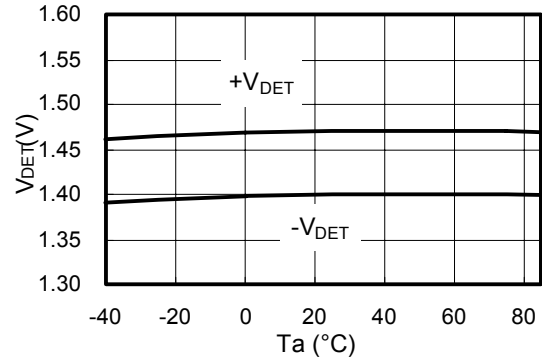

S-80915CN

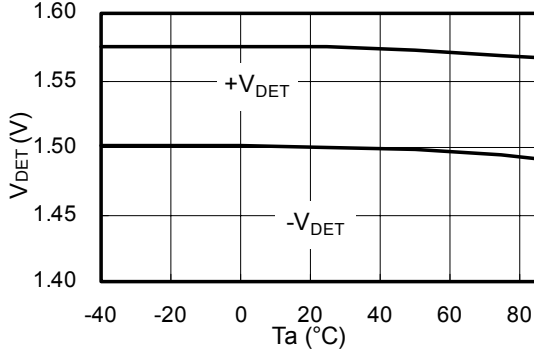

S-80960CN

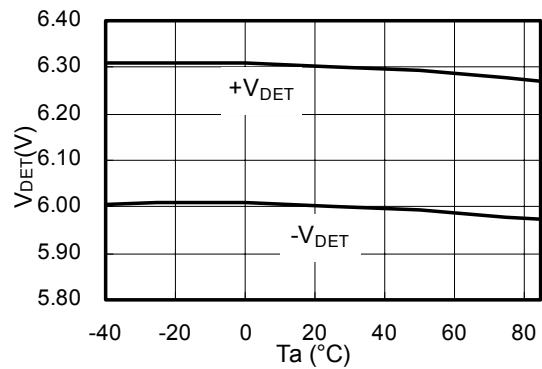

2. Hysteresis Voltage Width (V_{HYS}) - Temperature (T_a)

S-80913CN

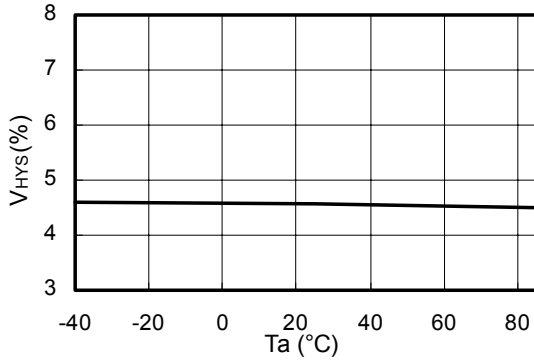

S-80914CN

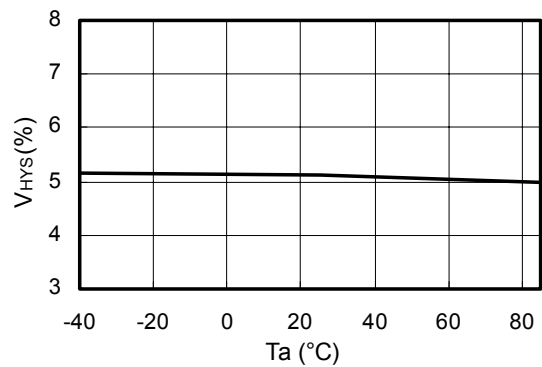

S-80915CN

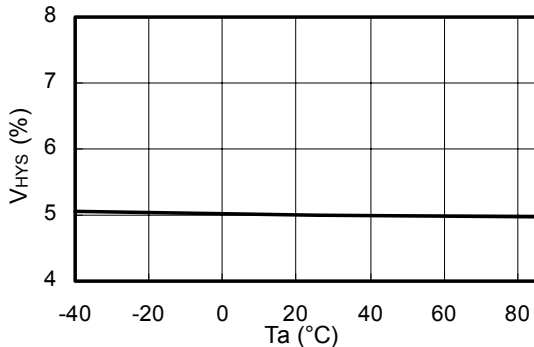

S-80960CN

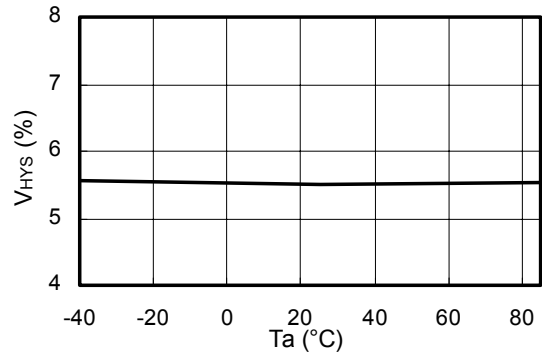

3. Current Consumption (I_{SS}) - Input Voltage (V_{DD})

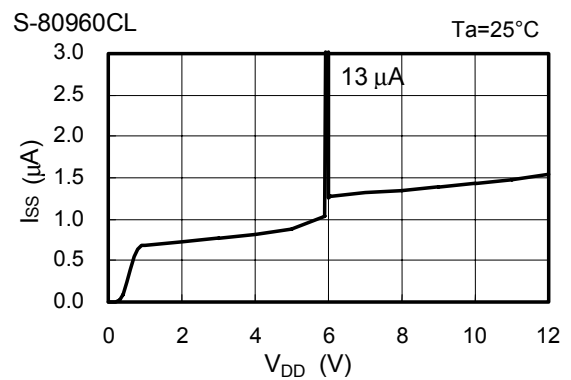
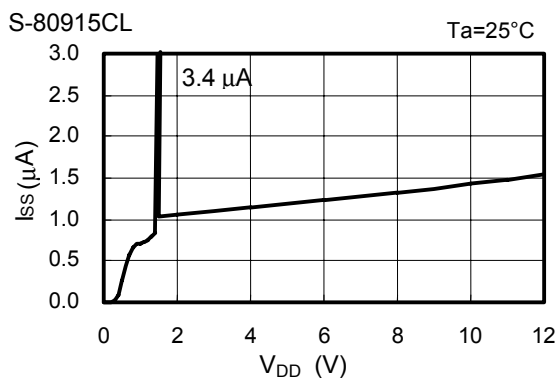
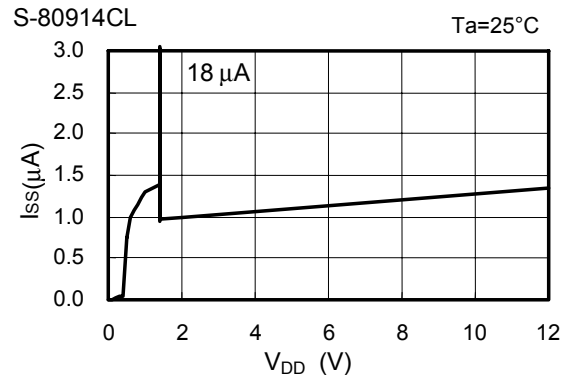
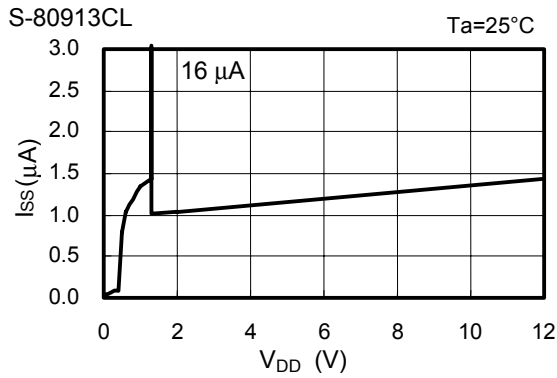

4. Current Consumption (I_{SS}) - Temperature (T_a)

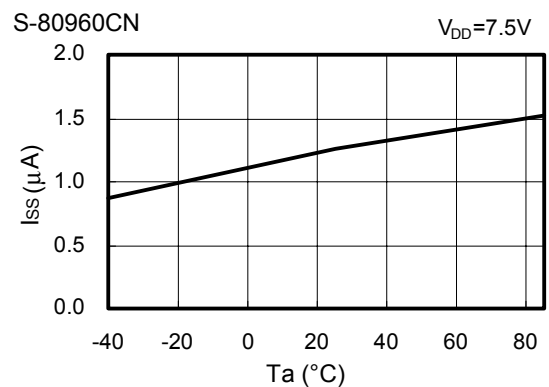
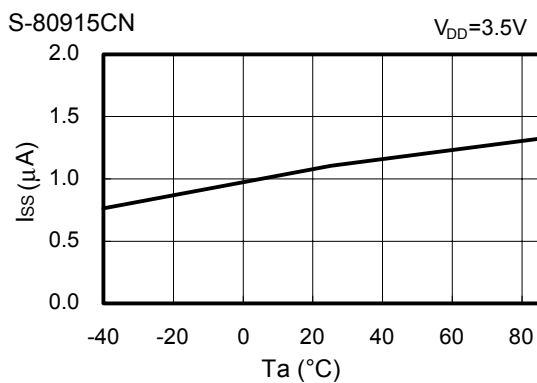
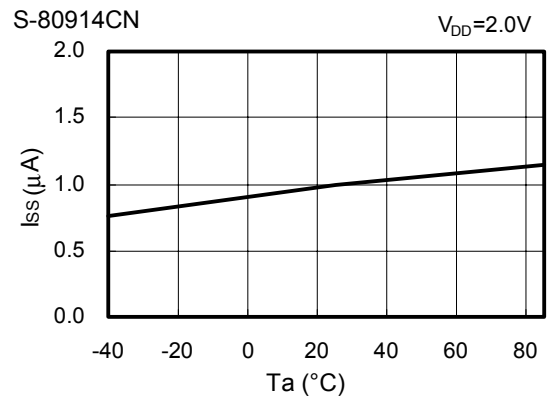
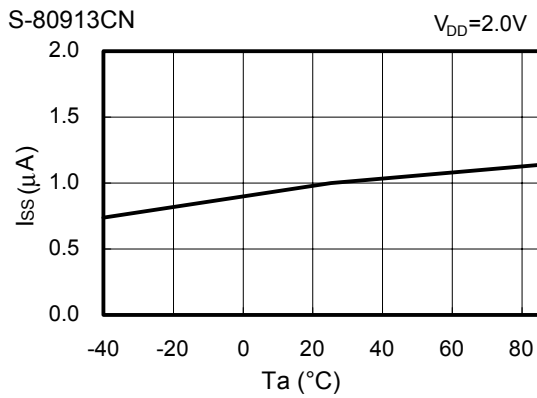

5. Nch Transistor Output Current (I_{OUT}) - V_{DS}

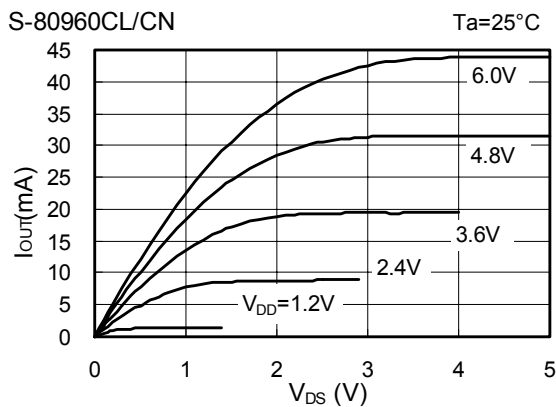

6. Pch Transistor Output Current (I_{OUT}) - V_{DS}

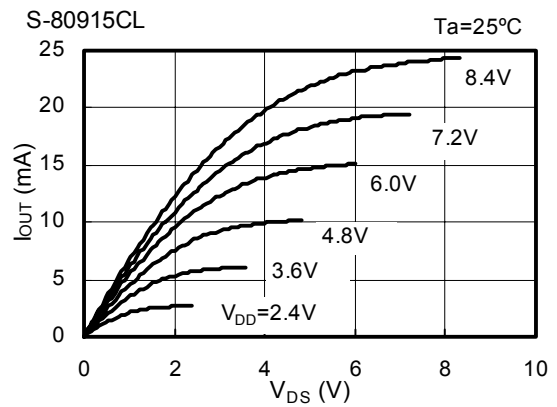

7. Nch Transistor Output Current (I_{OUT}) - Input Voltage (V_{DD})

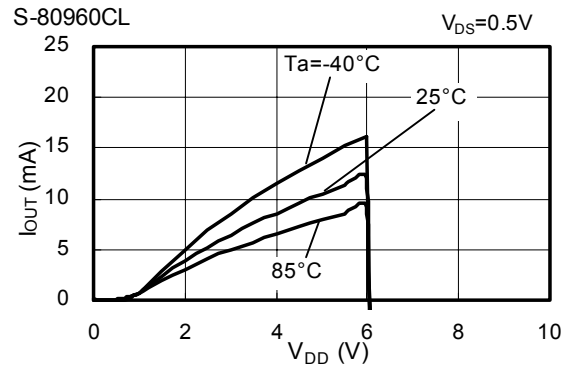
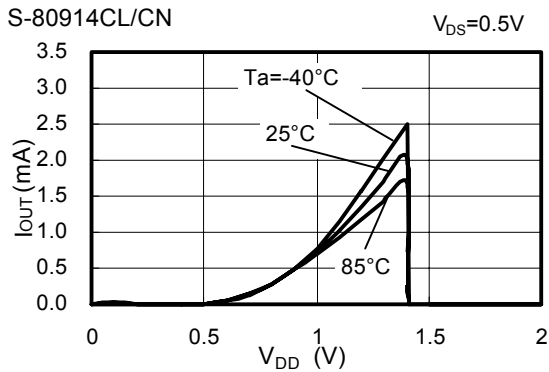

8. Pch Transistor Output Current (I_{OUT}) - Input Voltage (V_{DD})

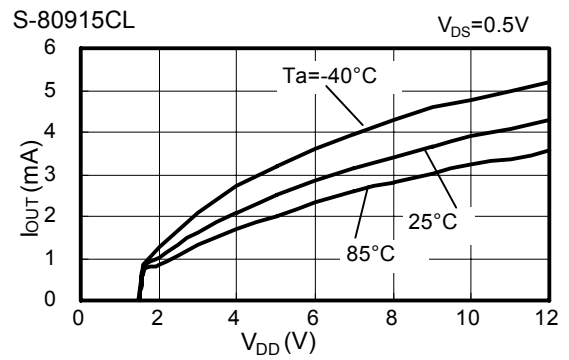
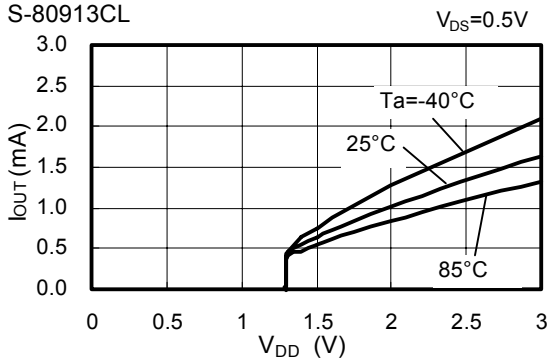

9. Minimum Operating Voltage - Input Voltage (V_{DD})

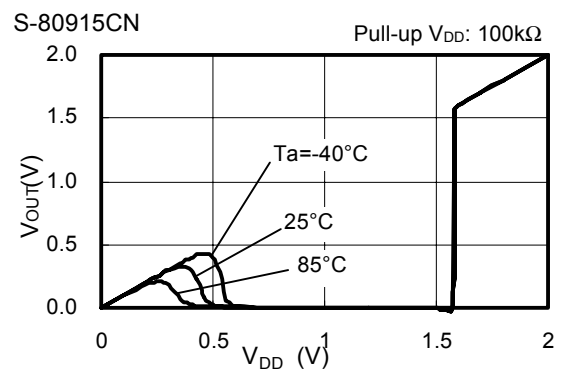
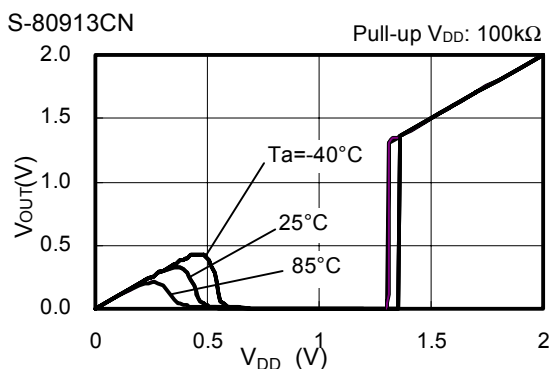

10. Dynamic Response - C_{OUT} (CD pin; open)

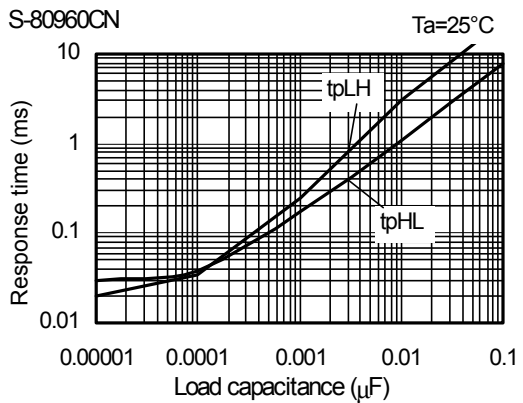
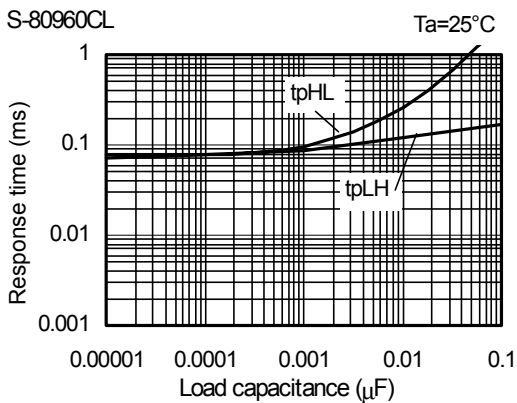
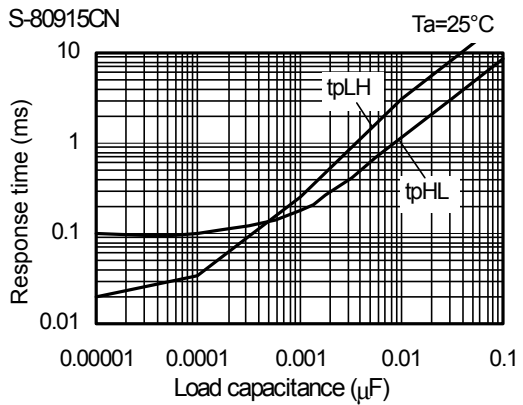
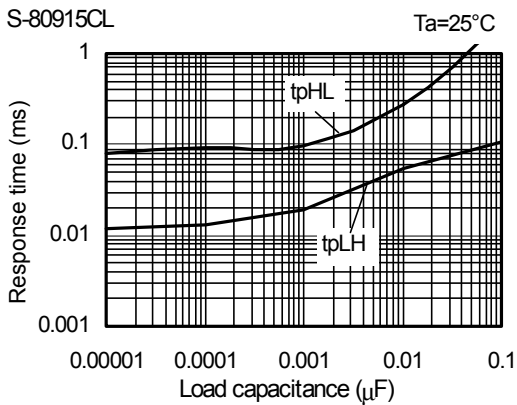
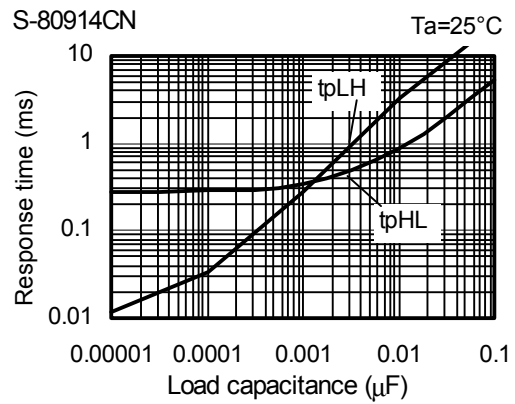
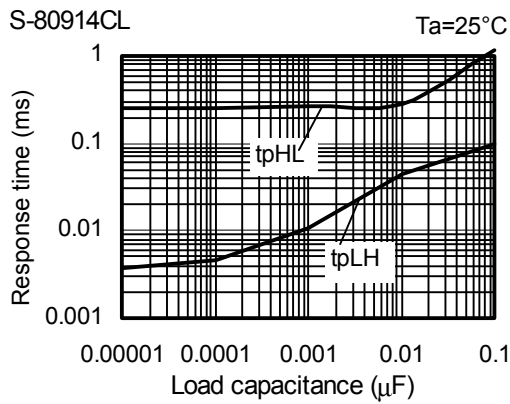
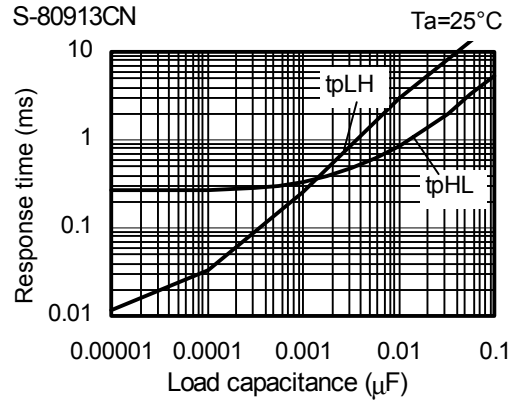
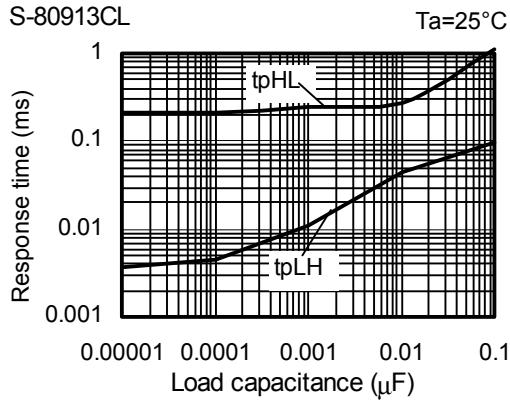

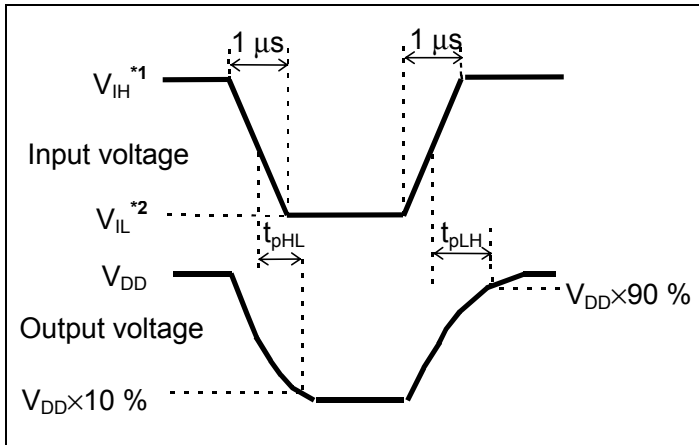

- *1. $V_{IH}=10\text{ V}$
- *2. $V_{IL}=0.7\text{ V}$

Figure 22 Measurement Condition for Response Time

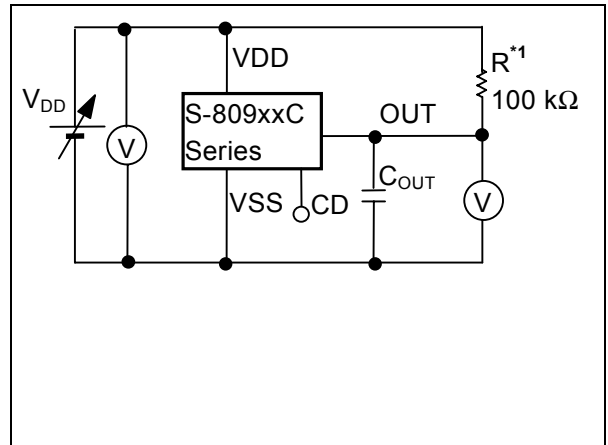

- *1. R is unnecessary for CMOS output products.

Figure 23 Measurement Circuit for rResponse Time

Caution The above connection diagram and constant will not guarantees successful operation. Perform through evaluation using the actual application to set the constant.

11. Delay Time - CD Pin Capacitance(C_D) (No output pin capacitance)

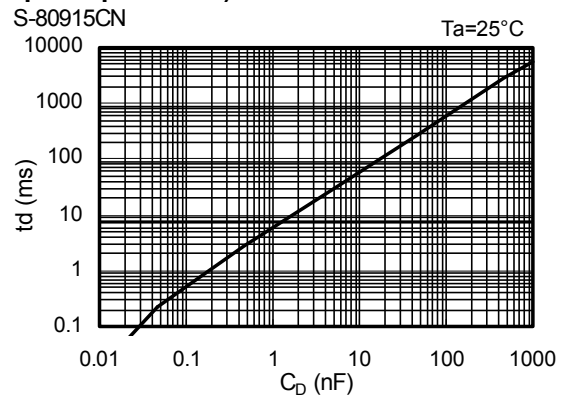
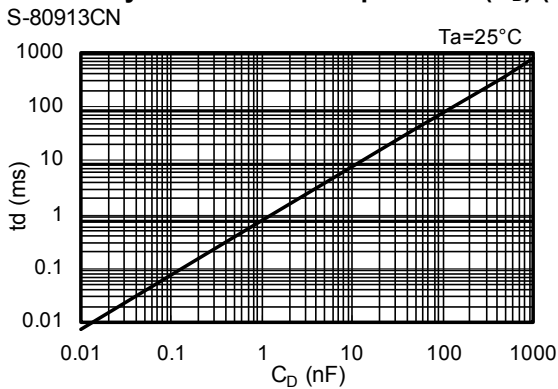

12. Delay Time - Temperature(T_a)

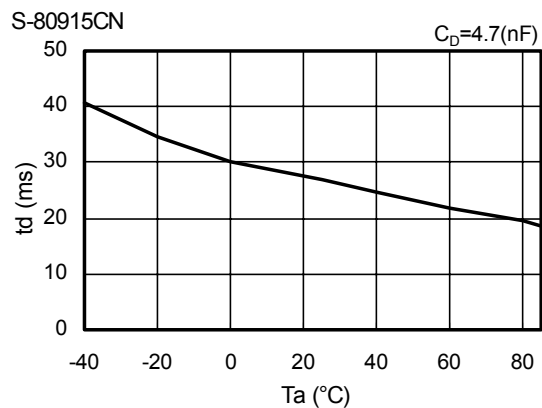
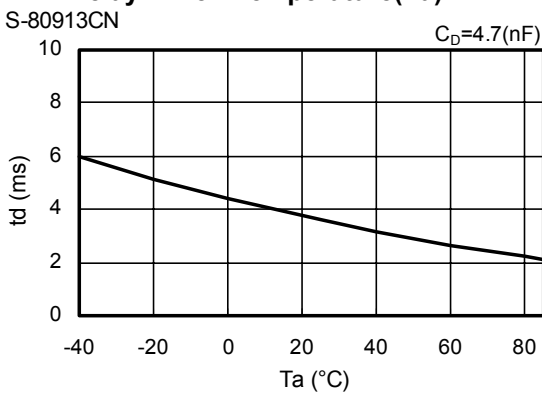

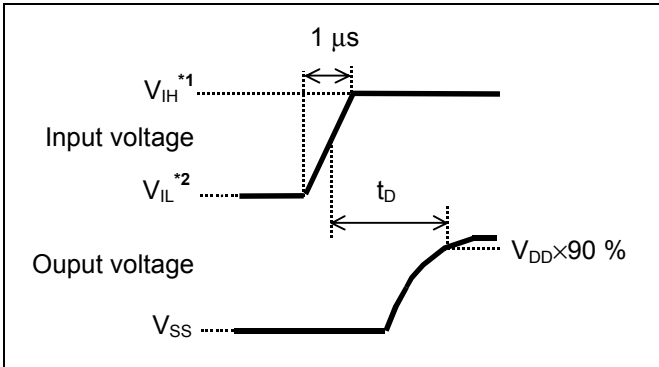

*1. $V_{IH}=10V$
 *2. $V_{IL}=0.7V$

Figure 24 Measuring Conditions of Delay Time

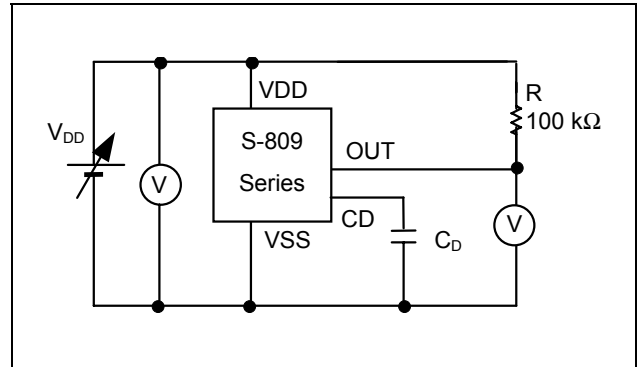

Figure 25 Measurement Circuit for Delay Time

Caution The above connection diagram and constant will not guarantees successful operation. Perform through evaluation using the actual application to set the constant.

■ Application Circuit Examples

1. Microcomputer Reset Circuits

If the power supply voltage to a microcomputer falls below the specified level, an unspecified operation may be performed or the contents of the memory register may be lost. When power supply voltage returns to normal, the microcomputer needs to be initialized before normal operations can be done. Reset circuits protect microcomputers in the event of current being momentarily switched off or lowered. Reset circuits shown in **Figures 26 to 27** can be easily constructed with the help of the S-809xxC Series that has a low operating voltage, a high-precision detection voltage, hysteresis and the reset circuits.

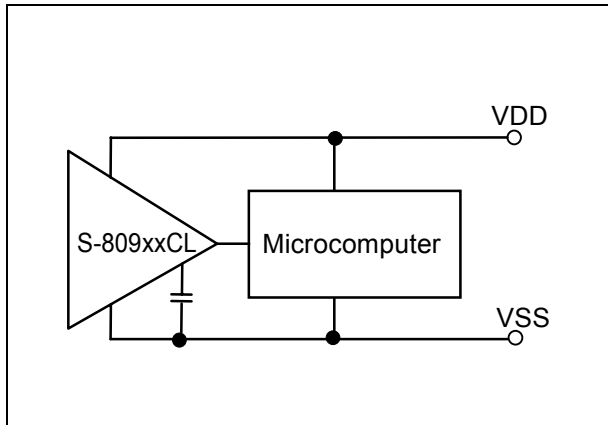

Figure 26 Example for Reset Circuits(S-809xxCL)

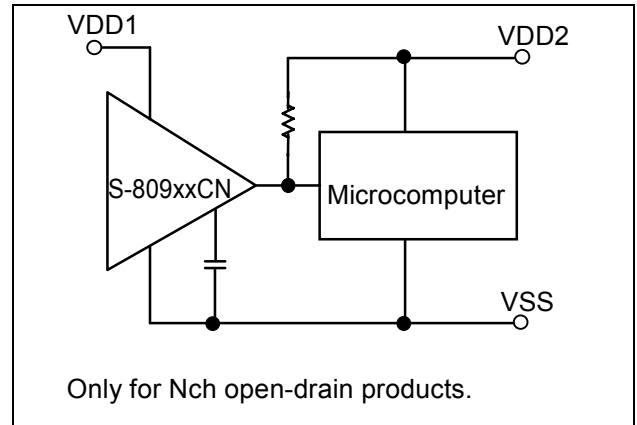
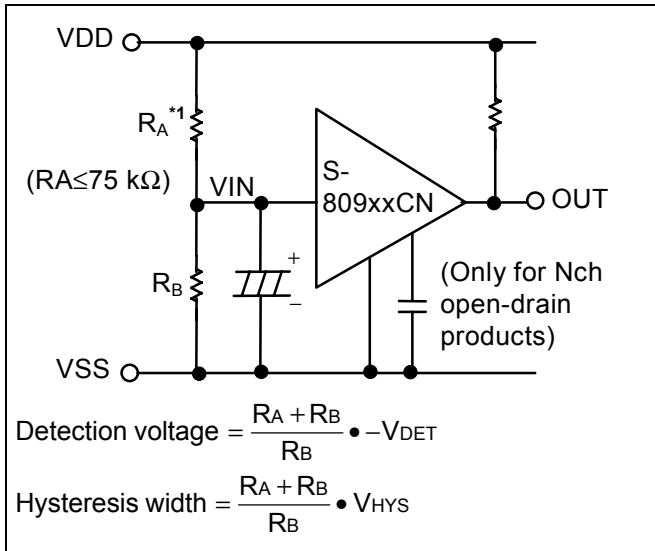

Figure 27 Example for Reset Circuits(S-809xxCN)

Caution The above connection diagram and constant will not guarantees successful operation. Perform through evaluation using the actual application to set the constant.

2. Change of Detection Voltage

In Nch open-drain output products of the S-809xxC Series, detection voltage can be changed using resistance dividers or diodes as shown in **Figures 28 to 29**. In **Figure 28**, hysteresis width also changes.



*1. RA should be 75 kΩ or less to prevent oscillation.

Remark If RA and RB are large, the hysteresis width may also be larger than the value given by the above equation due to through-type current (which flows slightly in an Nch open-drain products).

Figure 28

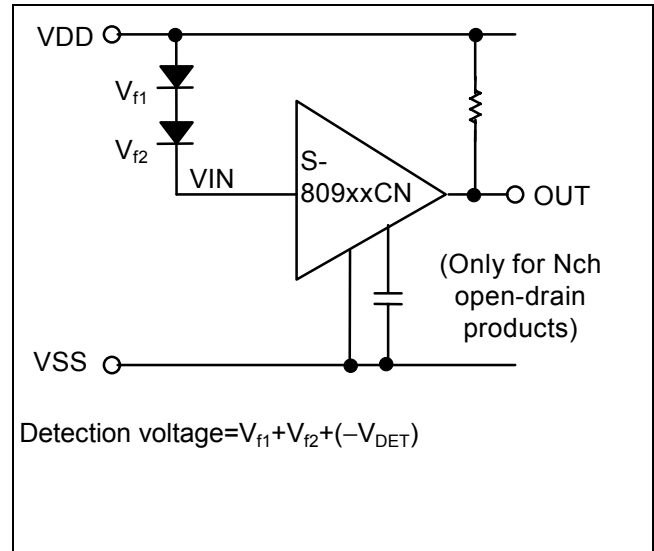
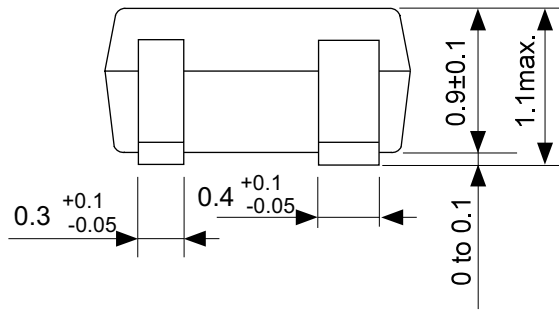
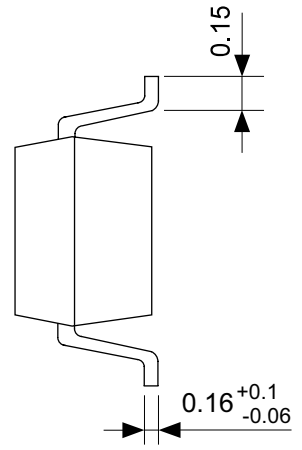
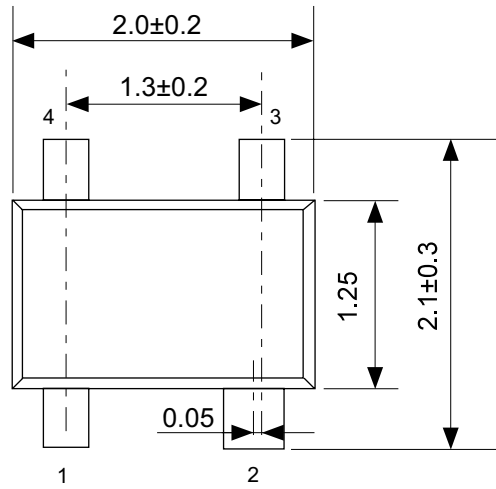

Figure 29

Caution The above connection diagram and constant will not guarantee successful operation. Perform through evaluation using the actual application to set the constant.



No. NP004-A-P-SD-1.1

TITLE	SC82AB-A-PKG Dimensions
No.	NP004-A-P-SD-1.1
SCALE	
UNIT	mm
Seiko Instruments Inc.	

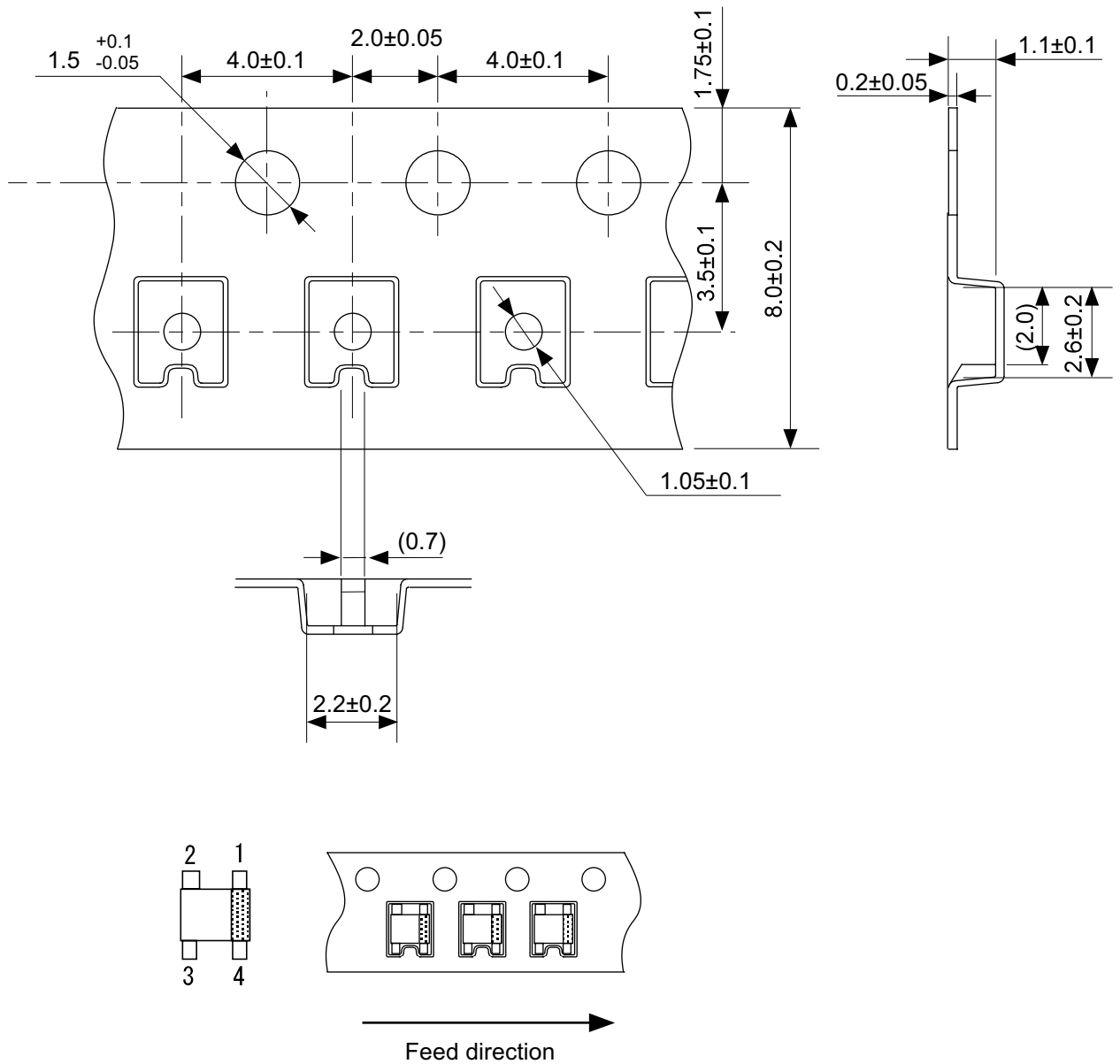

No. NP004-A-C-SD-2.1

TITLE	SC82AB-A-Carrier Tape
No.	NP004-A-C-SD-2.1
SCALE	
UNIT	mm
Seiko Instruments Inc.	

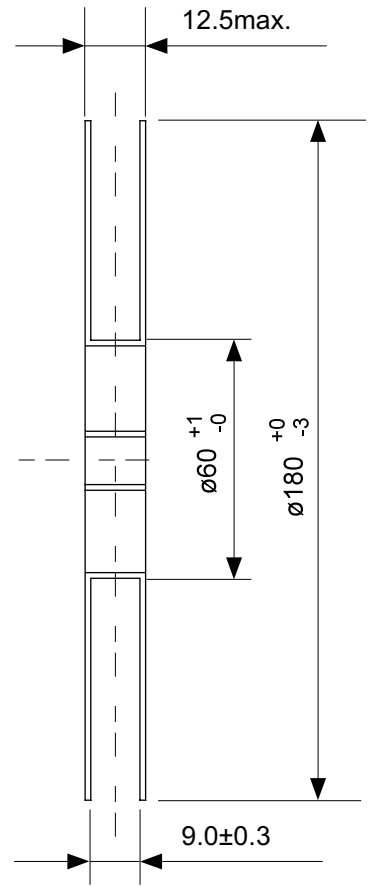
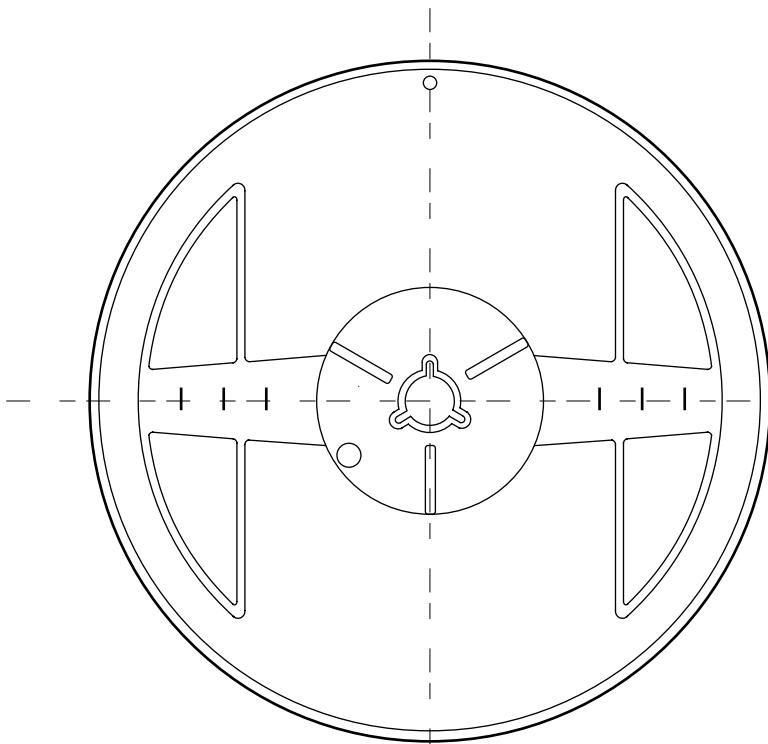

Enlarged drawing in the central part

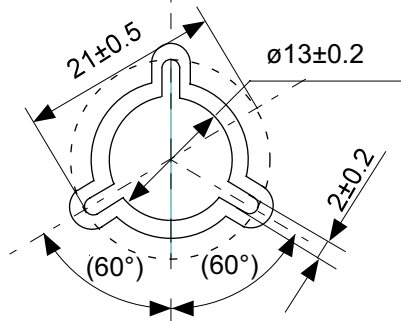

No. NP004-A-R-SD-1.1

TITLE	SC82AB-A-Reel		
No.	NP004-A-R-SD-1.1		
SCALE		QTY.	3,000
UNIT	mm		
Seiko Instruments Inc.			

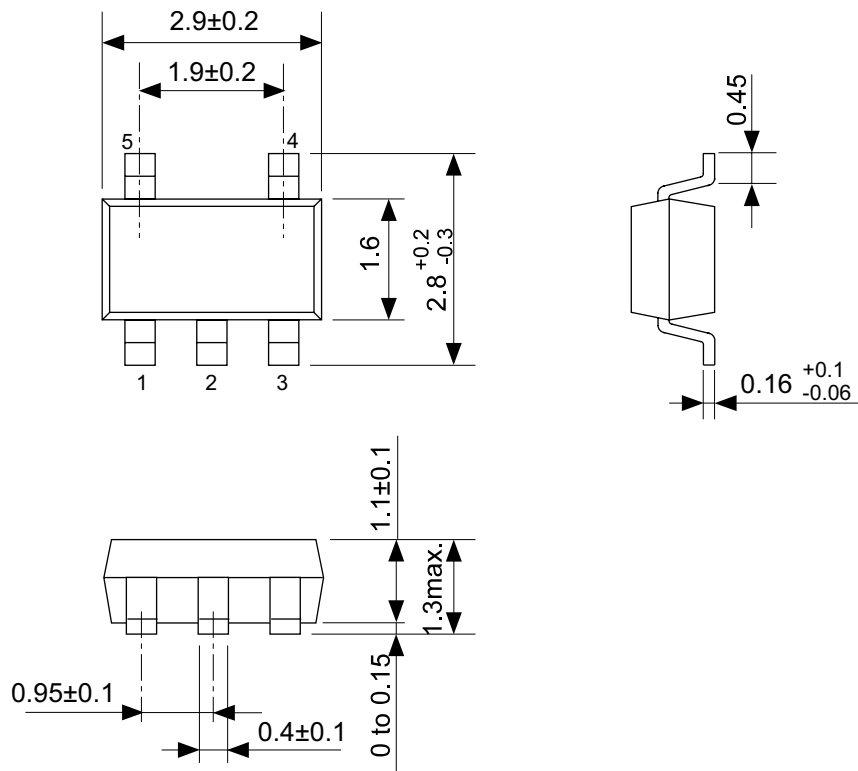

No. MP005-A-P-SD-1.2

TITLE	SOT235-A-PKG Dimensions
No.	MP005-A-P-SD-1.2
SCALE	
UNIT	mm
Seiko Instruments Inc.	

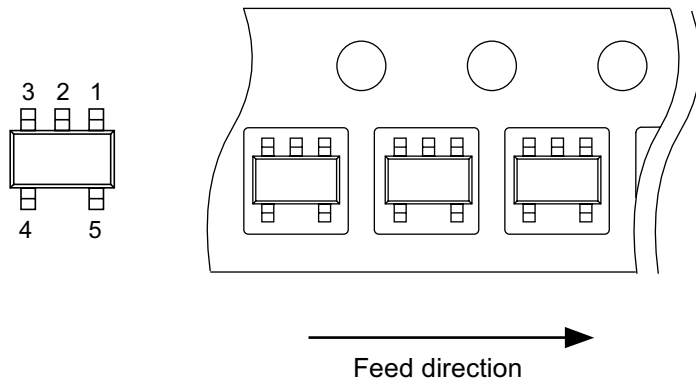
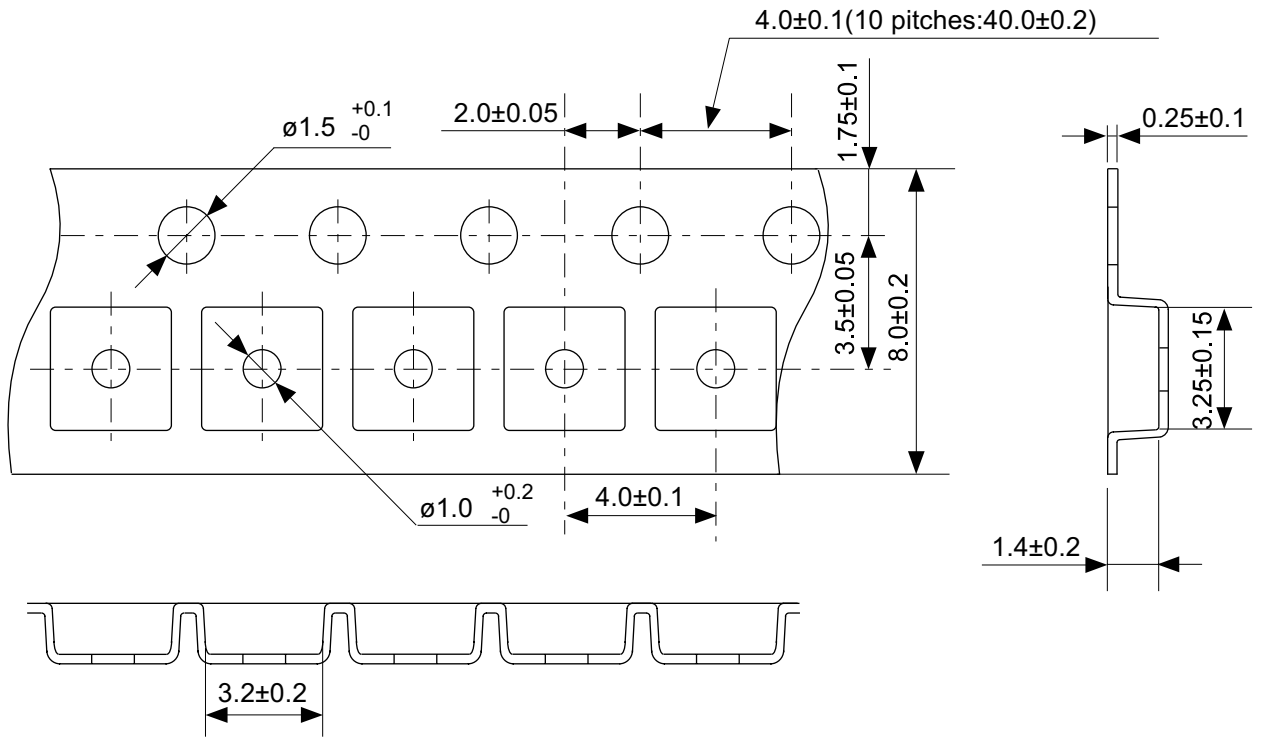

No. MP005-A-C-SD-2.1

TITLE	SOT235-A-Carrier Tape
No.	MP005-A-C-SD-2.1
SCALE	
UNIT	mm
Seiko Instruments Inc.	

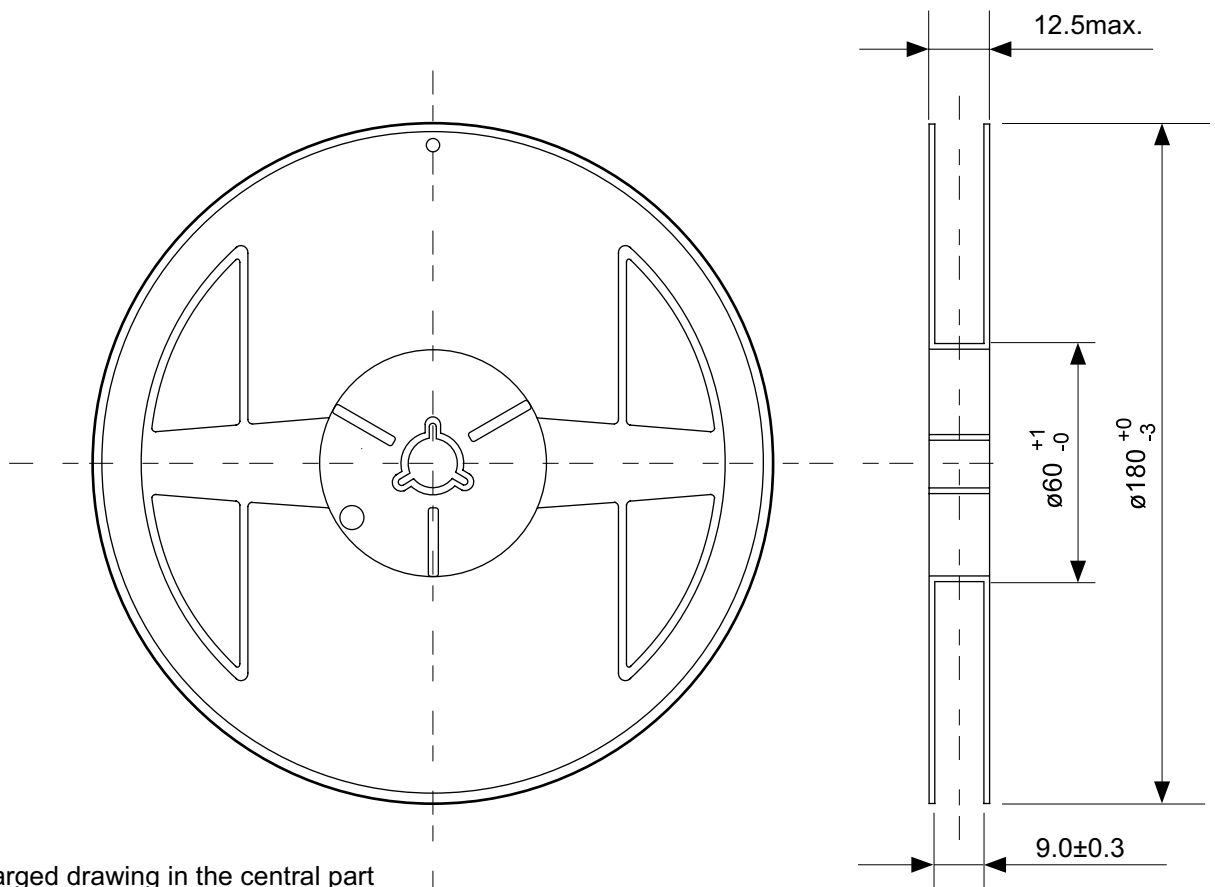

Enlarged drawing in the central part

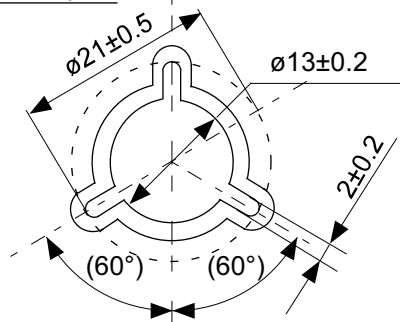

No. MP005-A-R-SD-1.1

TITLE	SOT235-A-Reel		
No.	MP005-A-R-SD-1.1		
SCALE		QTY.	3,000
UNIT	mm		
Seiko Instruments Inc.			

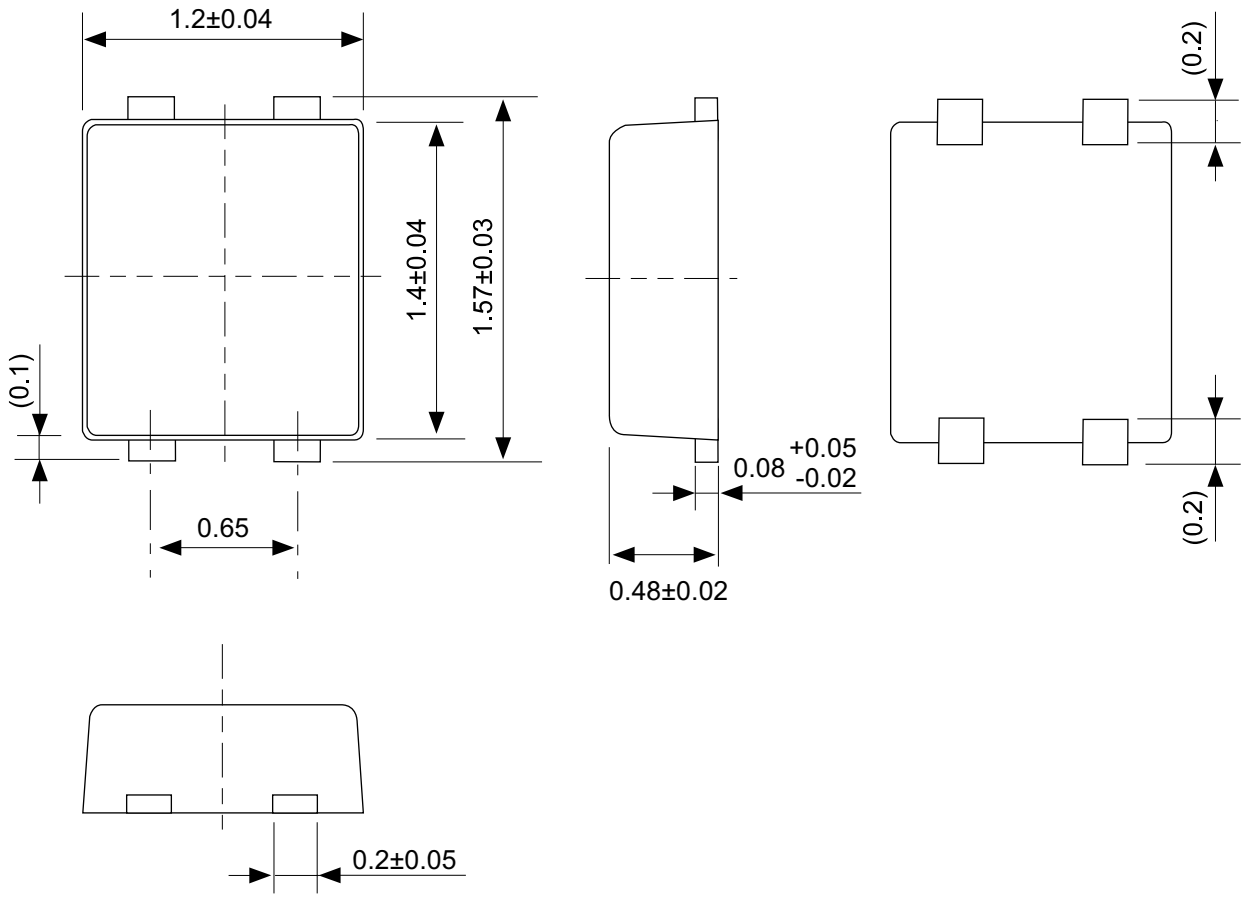

No. PF004-A-P-SD-3.0

TITLE	SNT-4A-A-PKG Dimensions
No.	PF004-A-P-SD-3.0
SCALE	
UNIT	mm
Seiko Instruments Inc.	

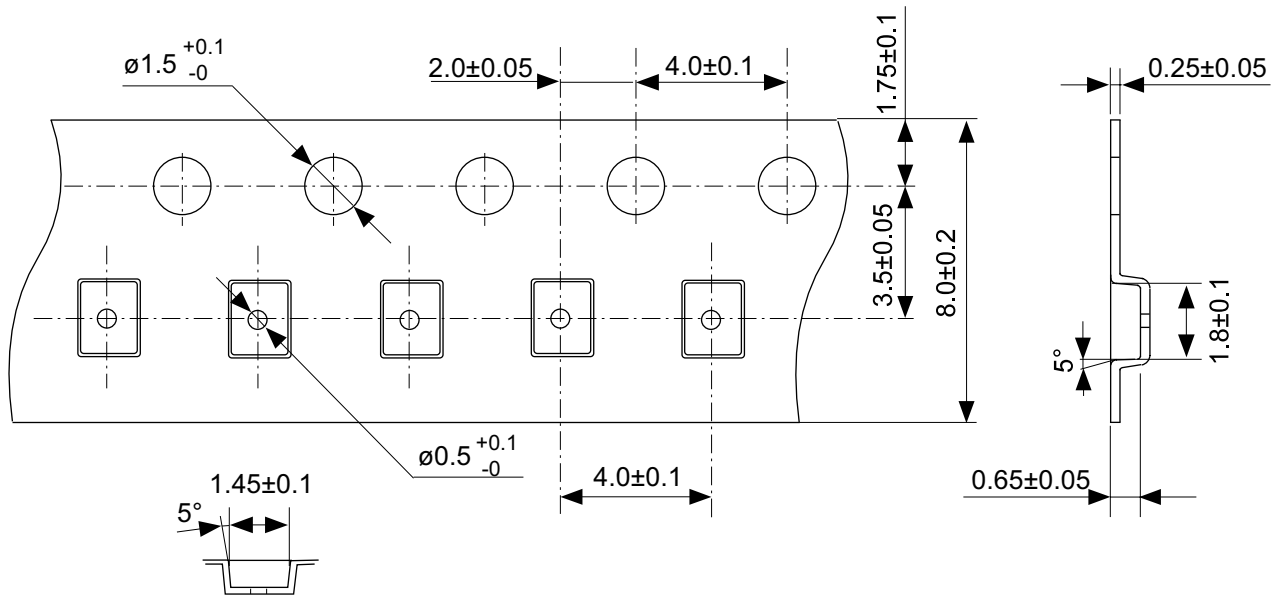

TF type

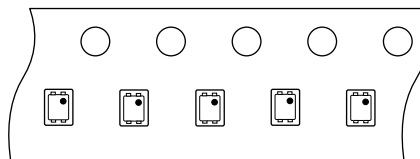
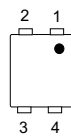

Feed direction

No. PF004-A-C-SD-1.0

TITLE	SNT-4A-A-Carrier Tape
No.	PF004-A-C-SD-1.0
SCALE	
UNIT	mm
Seiko Instruments Inc.	

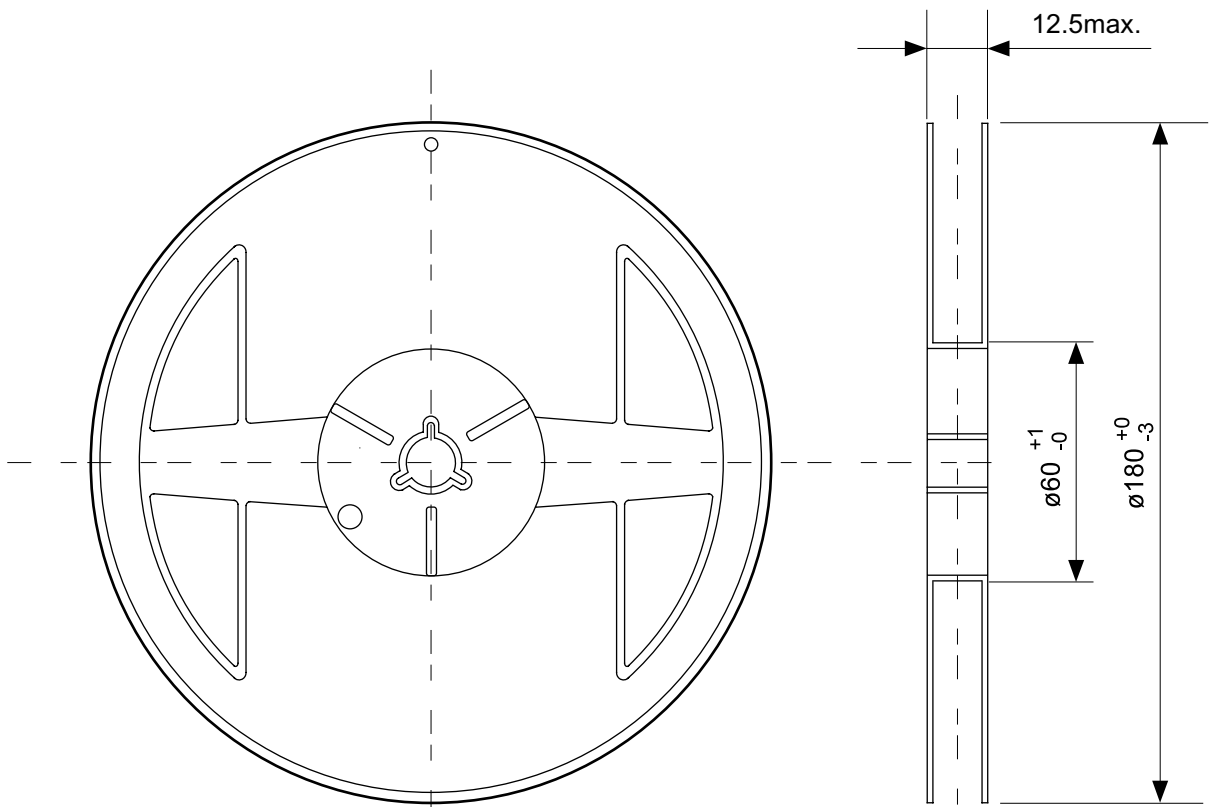

Enlarged drawing in the central part

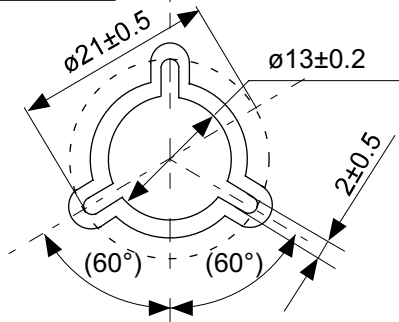

No. PF004-A-R-SD-1.0

TITLE	SNT-4A-A-Reel		
No.	PF004-A-R-SD-1.0		
SCALE		QTY.	5,000
UNIT	mm		
Seiko Instruments Inc.			

- The information described herein is subject to change without notice.
- Seiko Instruments Inc. is not responsible for any problems caused by circuits or diagrams described herein whose related industrial properties, patents, or other rights belong to third parties. The application circuit examples explain typical applications of the products, and do not guarantee the success of any specific mass-production design.
- When the products described herein are regulated products subject to the Wassenaar Arrangement or other agreements, they may not be exported without authorization from the appropriate governmental authority.
- Use of the information described herein for other purposes and/or reproduction or copying without the express permission of Seiko Instruments Inc. is strictly prohibited.
- The products described herein cannot be used as part of any device or equipment affecting the human body, such as exercise equipment, medical equipment, security systems, gas equipment, or any apparatus installed in airplanes and other vehicles, without prior written permission of Seiko Instruments Inc.
- Although Seiko Instruments Inc. exerts the greatest possible effort to ensure high quality and reliability, the failure or malfunction of semiconductor products may occur. The user of these products should therefore give thorough consideration to safety design, including redundancy, fire-prevention measures, and malfunction prevention, to prevent any accidents, fires, or community damage that may ensue.