

300mA LDO REGULATOR R1130XxxxA/B/C Series

■ OUTLINE

The R1130Xxxx Series are voltage regulator (VR) ICs by CMOS process. VR function has features of high ripple rejection, low dropout voltage, high output voltage accuracy, and ultra-low supply current. Each of these ICs consists of a voltage reference unit, an error amplifier, resistors for setting output voltage, and a current limit circuit. Each of the R1130xxxxA/B type includes also a chip enable circuit.

Output Voltage of the R1130xxxxC type is adjustable with external resistors.

Output Voltage of R1130xxxxA/B is fixed in the IC. Low supply current by the merit of CMOS process and built-in transistors with low ON-resistance make low dropout voltage. These regulators in the R1130xxxx Series are remarkable improvement on the current regulators in terms of ripple rejection, input transient response, and load transient response. Maximum Output Current is large for its compact size.

Thus, the R1130xxxx series are suitable for power supply for CD-drives, DVD-drives, and so forth.

Since the package for these ICs is the SOT-89-5 package or HSON-6P, high density mounting of the ICs on boards is possible.

■ FEATURES

- Ultra-Low Supply Current..... TYP. 50 μ A
- Low Standby Current..... TYP. 0.1 μ A (VR) for A type
- High Ripple Rejection..... TYP. 60dB(f=1kHz)(VR)
- Output Current..... MIN. 300mA($V_{in}=V_{out}+1V$)
- Output Voltage (VR)..... Stepwise setting with a step of 0.1V in the range of 1.5 to 5.0V(A/B Version)
(Reference 1.8V(C Version))
- High Output Voltage Accuracy..... $\pm 2.0\%$ (VR) for A/B type,
 $\pm 2.0\%$ (Reference Voltage for adjustable VR) for C type
- Low Dropout Voltage..... TYP. 0.2V($I_{OUT}=100mA$)(VR)
- Small Packages..... SOT-89-5, HSON-6P
- Built-in Current Limit Circuit
- Low Temperature-drift Coefficient of Output Voltage..... TYP. $\pm 100ppm/^{\circ}C$
- Absolute Maximum Voltage..... 9V
- Internal Phase Compensation (small output capacitance such as 0.1 μ F Ceramic can be used with.)

■ APPLICATIONS

- Power source for CD-drives and DVD-drives, HDD.
- Local Power source for Notebook PC.

■ BLOCK DIAGRAMS

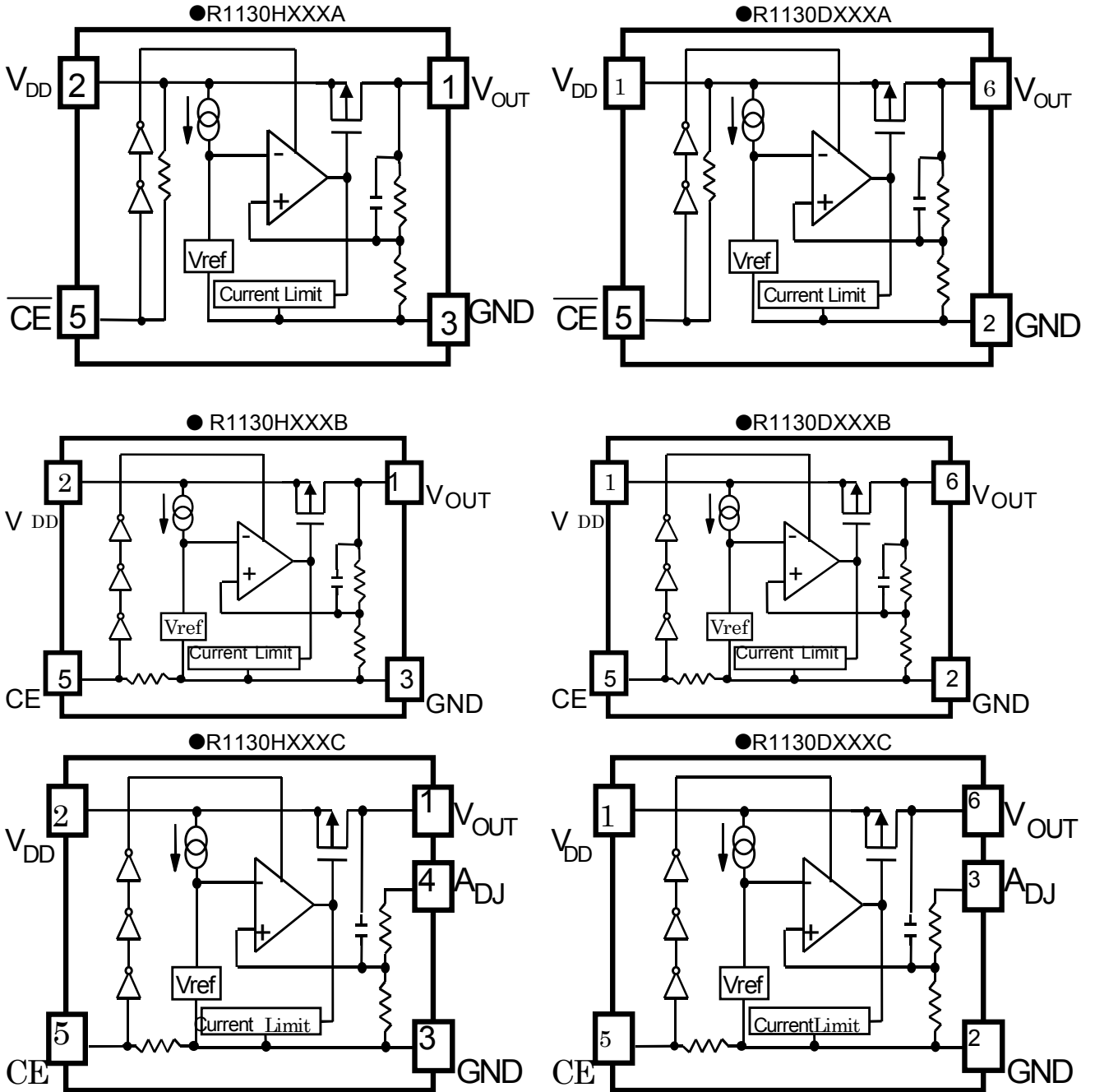

SELECTION GUIDE

The output voltage, chip-enable polarity, the taping type can be selected at the user's request. The selection can be made with designating the part number as follows;

R1130X XXXX-XX ← Part Number
 ↑ ↑ ↑ ↑
 a b c d

Code	Contents
a	Package Type; H: SOT89-5, D: HSON6
b	Serial Number for Voltage Setting
c	Designation of option; A: Fixed Output Voltage Regulator with $\overline{\text{CE}}$ pin ("L" enable) B: Fixed Output Voltage Regulator with CE pin ("H" enable) C: Output Voltage Adjustable Regulator with CE pin ("H" enable)
d	Designation of Taping Type; T1 or T2 (Refer to Taping Specifications) for SOT89-5 TR or TL for HSON-6P

PIN CONFIGURATION

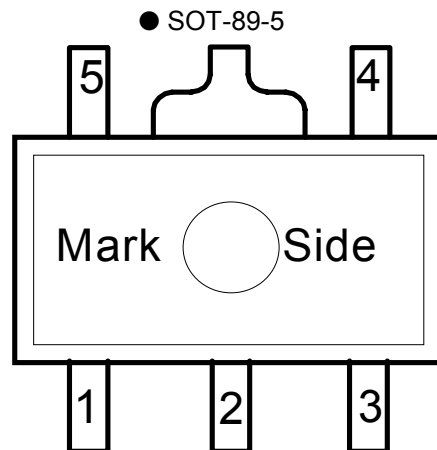

● HSON-6P

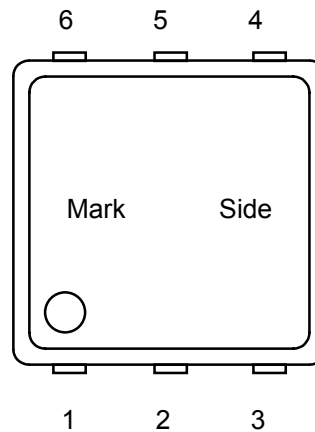

■ PIN DESCRIPTION

SOT89-5

Pin No.	Symbol	Description
1	VOUT	Voltage Regulator Output Pin
2	VDD	Input Pin
3	GND	Ground Pin
4	N.C.(A/B type)	No Connection
	ADJ(C type)	Adjustable Regulator feedback Input Pin (Connect to resistor voltage divider.)
5	\overline{CE} (A type) or CE(B/C type)	Chip Enable Pin

HSON-6P

Pin No.	Symbol	Description
1	VDD	Input Pin
2	GND	Ground Pin
3	N.C.(A/B type)	No Connection
	ADJ(C type)	Adjustable Regulator feedback Input Pin (Connect to resistor voltage divider.)
4	N.C.	No Connection
5	\overline{CE} (A type) or CE(B/C type)	Chip Enable Pin
6	VOUT	Voltage Regulator Output Pin

■ ABSOLUTE MAXIMUM RATINGS

Item	Symbol	Rating	Unit
Input Voltage	V _{IN}	9.0	V
Input Voltage(\overline{CE} or CE Input Pin)	V _{CE}	-0.3 ~ V _{IN} +0.3	V
Input Voltage(ADJ Input Pin)	V _{ADJ}	-0.3 ~ V _{IN} +0.3	V
Output Voltage	V _{OUT}	-0.3 ~ V _{IN} +0.3	V
Output Current	I _{OUT}	450	mA
Power Dissipation (SOT-89-5)	P _D	500	mW
Operating Temperature	T _{opt}	-40 ~ 85	°C
Storage Temperature	T _{stg}	-55 ~ 125	°C

■ ELECTRICAL CHARACTERISTICS

●R1130XxxxA

(T_{opt}=25°C)

Symbol	Item	Conditions	MIN.	TYP.	MAX.	Unit
V _{IN}	Input Voltage		2.5		8.0	V
I _{SS1}	Supply Current1	V _{IN} -V _{OUT} =1.0V V _{IN} =GND		50	100	μA
I _{stby}	Standby Current	V _{IN} -V _{OUT} =1.0V V _{IN} =V _{CE}		0.1	1.0	μA
V _{OUT}	Output voltage	V _{IN} -V _{OUT} =1.0V 1mA≤I _{OUT} ≤80mA	x0.98	Set V _{OUT}	x1.02	V
I _{OUT1}	Output Current	Refer to the table of Input Voltage by Set Output Voltage	300			mA
ΔV _{OUT} / ΔI _{OUT}	Load regulation	V _{IN} -V _{OUT} =1.0V 1mA≤I _{OUT} ≤80mA		40	80	mV
V _{DIF}	Dropout Voltage	I _{OUT} =100mA	Refer to the Table of Dropout Voltage by Set Output Voltage			
ΔV _{OUT} / ΔV _{IN}	Line regulation	I _{OUT} =80mA, Set V _{OUT} ≥2.0V:V _{OUT} +0.5V≤V _{IN} ≤8.0V Set V _{OUT} ≤1.9V:2.5V≤V _{IN} ≤8.0V		0.1	0.2	%/V
RR	Ripple Rejection	f=1kHz,Ripple 0.5Vp-p, I _{OUT} =80mA Set V _{OUT} ≥1.8V:V _{IN} -V _{OUT} =1.0V Set V _{OUT} ≤1.7V: V _{IN} =2.8V		60		dB
ΔV _{OUT} / ΔT	Output Voltage Temperature Coefficient	I _{OUT} =10mA, V _{IN} -V _{OUT} =1.0V -40°C ≤ T _{opt} ≤ 85°C		±100		ppm /°C
I _{LIM}	Short Current Limit	Set V _{OUT} ≤3.9V, V _{OUT} =0V Set V _{OUT} ≥4.0V, V _{OUT} =0V		70 50		mA
R _{PU}	Pull-up resistance for CE pin		2.5	5.0	10.0	MΩ
V _{CEH}	CE Input Voltage "H"	V _{IN} =2.5V	1.5		V _{IN}	V
V _{CEL}	CE Input Voltage "L"	V _{IN} =2.5V	0.00		0.25	V

●R1130XxxxB

(Topt=25°C)

Symbol	Item	Conditions	MIN.	TYP.	MAX.	Unit
VIN	Input Voltage		2.5		8.0	V
ISS1	Supply Current1	VIN-VOUT=1.0V VIN=VCE		50	100	μA
Istby	Standby Current	VIN-VOUT=1.0V VIN=GND		0.1		μA
VOUT	Output voltage	VIN-VOUT=1.0V 1mA≤IOUT≤80mA	x0.98	Set VOUT	x1.02	V
IOUT1	Output Current	Refer to the table of Input Voltage by Set Output Voltage	300			mA
ΔVOUT/ ΔIOUT	Load regulation	VIN-VOUT=1.0V 1mA≤IOUT≤80mA		40	80	mV
VDIF	Dropout Voltage	IOUT=100mA	Refer to the Table of Dropout Voltage by Set Output Voltage			
ΔVOUT/ ΔVIN	Line regulation	IOUT=80mA Set VOUT≥2.0V: VOUT+0.5V≤VIN≤8V Set VOUT≤1.9V: 2.5V≤VIN≤8.0V		0.1	0.2	%/V
RR	Ripple Rejection	f=1kHz, Ripple 0.5Vp-p, IOUT=80mA Set VOUT≥1.8V: VIN-VOUT=1.0V Set VOUT≤1.7V: VIN=2.8V		60		dB
ΔVOUT/ ΔTopt	Output Voltage Temperature Coefficient	IOUT=10mA, VIN-VOUT=1.0V -40°C ≤ Topt ≤ 85°C		±100		ppm /°C
ILIM	Short Current Limit	Set VOUT≤3.9V, VOUT=0V		70		mA
		Set VOUT≥4.0V, VOUT=0V		50		
RPD	Pull-down resistance for CE pin		2.5	5	10	MΩ
VCEH	CE Input Voltage "H"	VIN=2.5V	1.5		VIN	V
VCEL	CE Input Voltage "L"	VIN=2.5V	0		0.25	V

●Dropout Voltage by Set Output Voltage (Topt=25°C) ●Input Voltage by Set Output Voltage (Topt=25°C)

Output Voltage VOUT(V)	Dropout Voltage (V)	
	TYP.	MAX.
VOUT=1.5	1.00	1.05
VOUT=1.6	0.90	0.95
VOUT=1.7	0.80	0.85
VOUT=1.8	0.70	0.75
VOUT=1.9	0.60	0.65
VOUT=2.0	0.50	0.60
VOUT=2.1	0.40	0.55
2.2V≤VOUT≤2.5V	0.30	0.49
2.6V≤VOUT≤3.3V	0.25	0.34
3.4V≤VOUT≤5.0V	0.20	0.28

Output Voltage VOUT(V)	Input Voltage (V)
1.5V≤VOUT≤1.9V	VIN=VOUT+1.5V
2.0V≤VOUT≤2.7V	VIN=VOUT+1.3V
2.8V≤VOUT≤5.0V	VIN=VOUT+1.0V

●R1130xxxxC

(T_{opt}=25°C)

Symbol	Item	Conditions	MIN.	TYP.	MAX.	Unit
V _{IN}	Input voltage		2.5		8.0	V
I _{SS1}	Supply Current	V _{IN} -V _{OUT} =1.0V, V _{IN} =V _{CE}		50	100	μA
I _{stby}	Standby Current	V _{IN} -V _{OUT} =1.0V V _{IN} =GND		0.1	1.0	μA
V _{OUT}	Reference Voltage for Adjustable Voltage Regulator	V _{OUT} =V _{ADJ} , V _{IN} -V _{OUT} =1.0V I _{OUT} =80mA	1.764	1.800	1.836	V
I _{OUT1}	Output Current	V _{OUT} =V _{ADJ} , V _{IN} -V _{OUT} =1.5V	300			mA
ΔV _{OUT} / ΔI _{OUT}	Load regulation	V _{IN} =2.5V, V _{OUT} =V _{ADJ} 1mA≤I _{OUT} ≤80mA		40	80	mV
V _{DIF}	Dropout Voltage	I _{OUT} =100mA, V _{OUT} =V _{ADJ}		0.70	0.75	V
ΔV _{OUT} / ΔV _{IN}	Line regulation	I _{OUT} =80mA, V _{OUT} =V _{ADJ} 2.5V≤V _{IN} ≤8V		0.1	0.2	%/V
RR	Ripple Rejection	f=1kHz, Ripple 0.5Vp-p, I _{OUT} =80mA, V _{IN} -V _{OUT} =1.0V V _{OUT} =V _{ADJ} , I _{OUT} =80mA		60		dB
ΔV _{OUT} / ΔT _{opt}	Output Voltage Temperature Coefficient	I _{OUT} =10mA, V _{IN} -V _{OUT} =1.0V -40°C ≤ T _{opt} ≤ 85°C		±100		ppm /°C
I _{LIM}	Short Current Limit	V _{OUT} =0V		70		mA
R _{PD}	Pull-down resistance for CE pin		2.5	5	10	MΩ
V _{CEH}	CE Input Voltage "H"	V _{IN} =2.5V	1.5		V _{IN}	V
V _{CEL}	CE Input Voltage "L"	V _{IN} =2.5V	0		0.25	V

TEST CIRCUITS

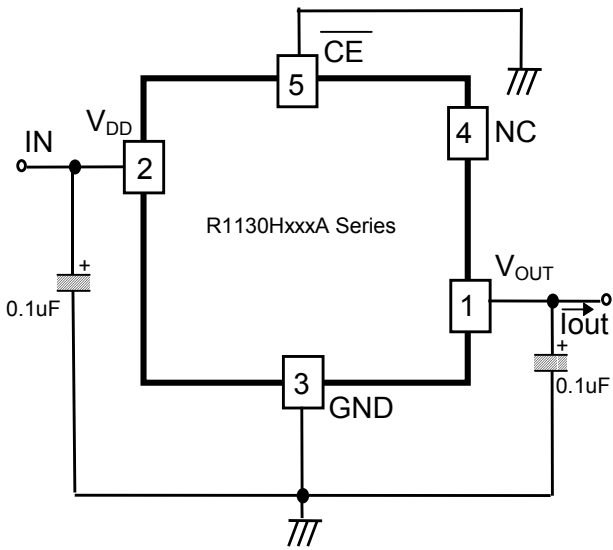

Standard Test Circuit

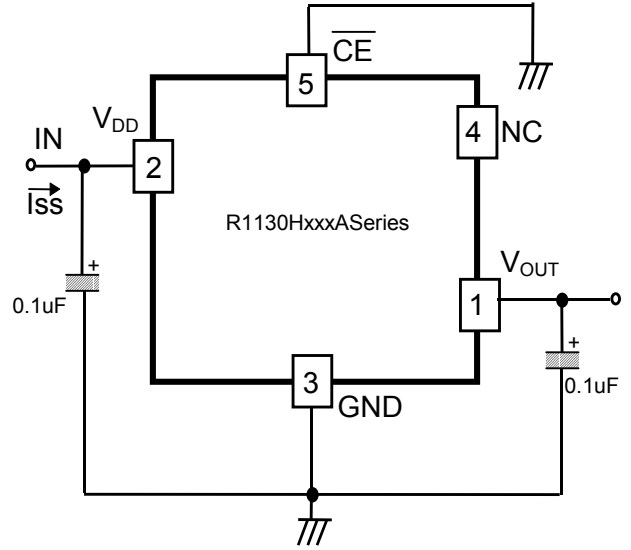

Test Circuit for Supply Current

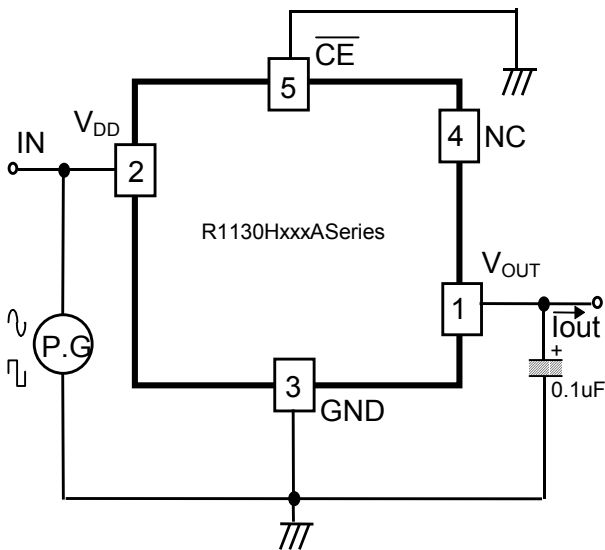

Test Circuit for Ripple Rejection and Input Transient Response

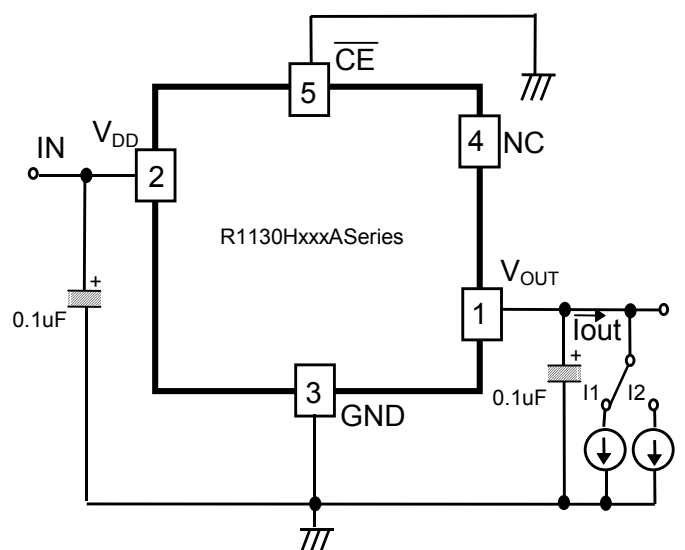

Test Circuit for Load Transient Response

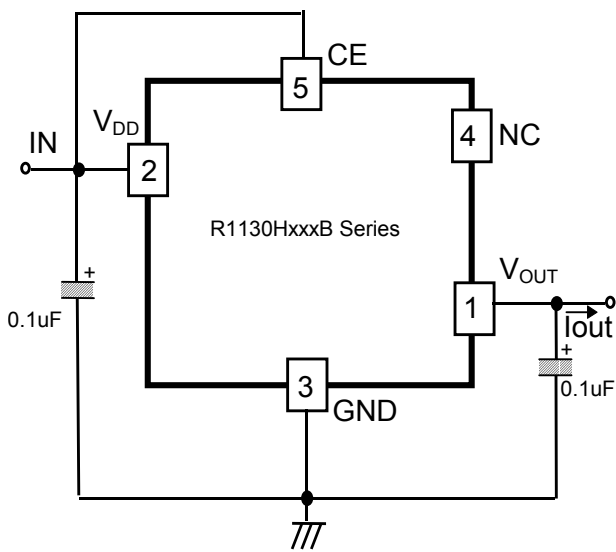

Standard Test Circuit

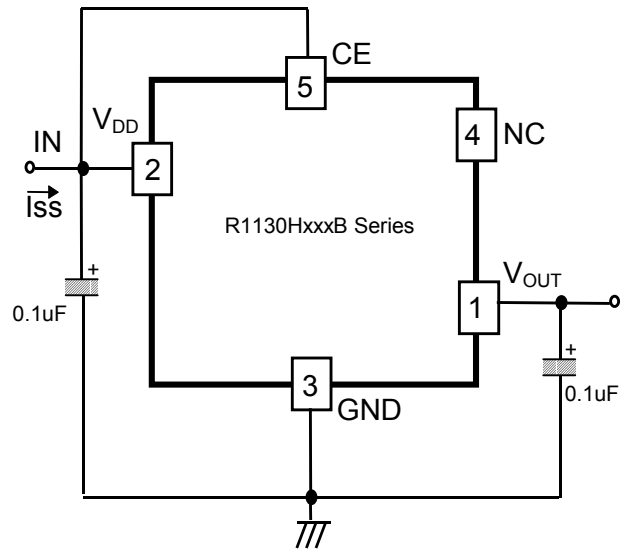

Test Circuit for Supply Current

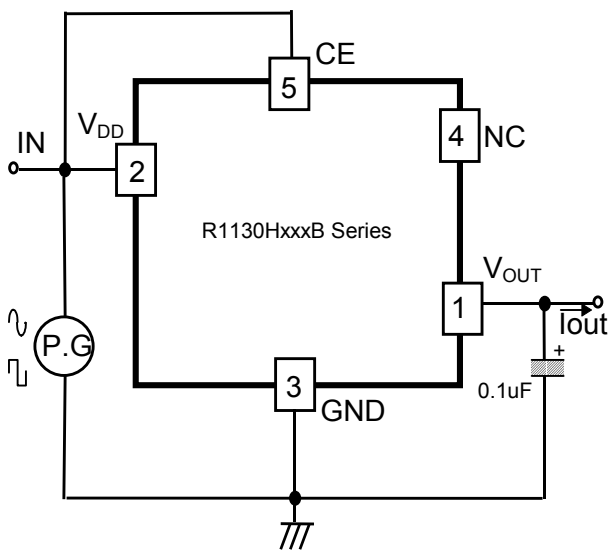

Test Circuit for Ripple Rejection and Input Transient Response

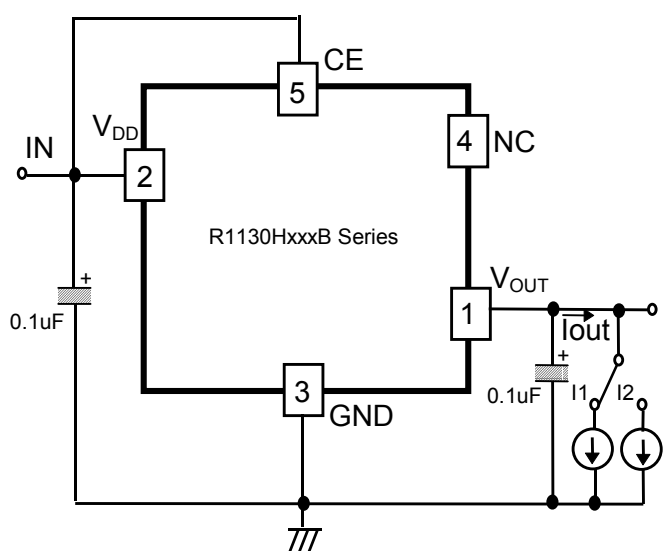

Test Circuit for Load Transient Response

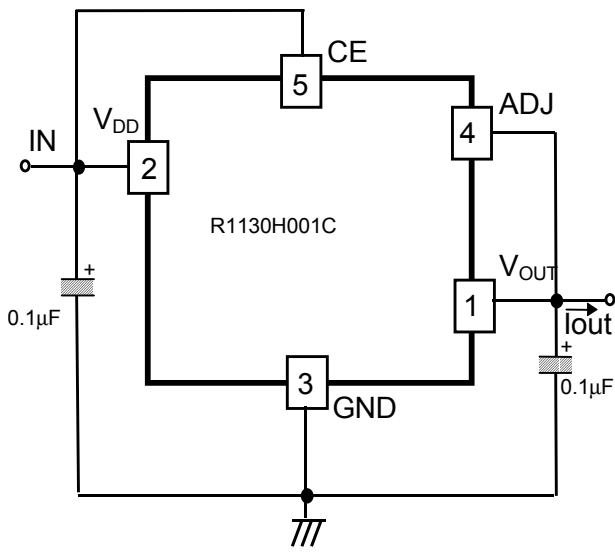

Standard Test Circuit

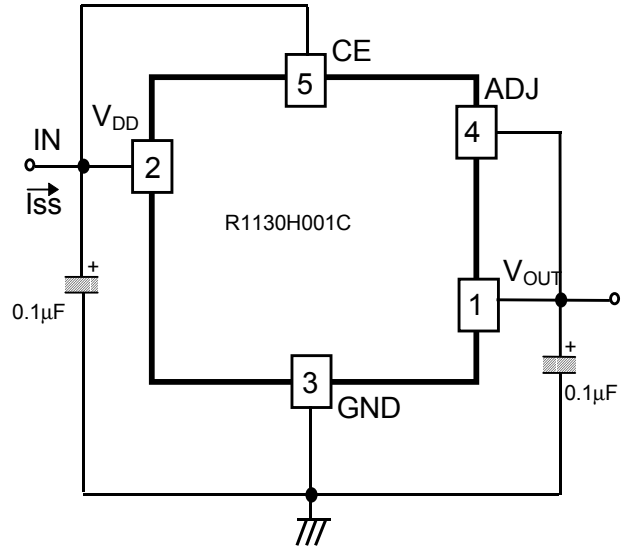

Test Circuit for Supply Current

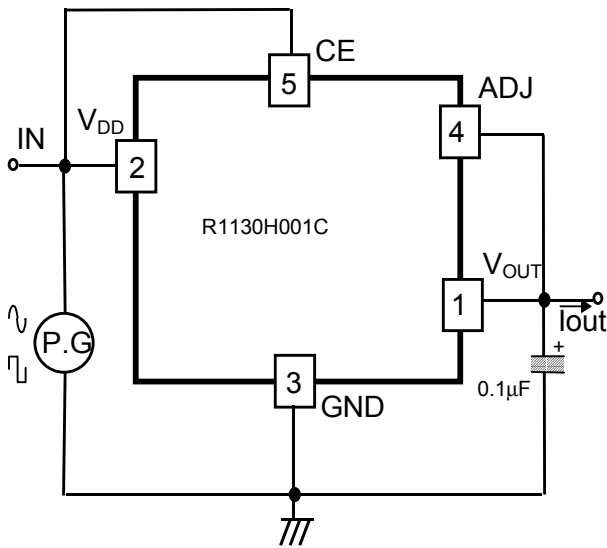

Test Circuit for Ripple Rejection and Input Transient Response

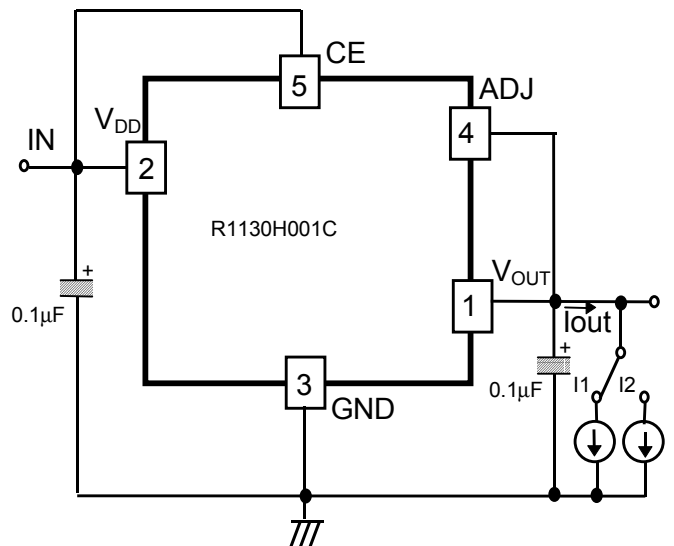

Test Circuit for Load Transient Response

■ TYPICAL APPLICATION

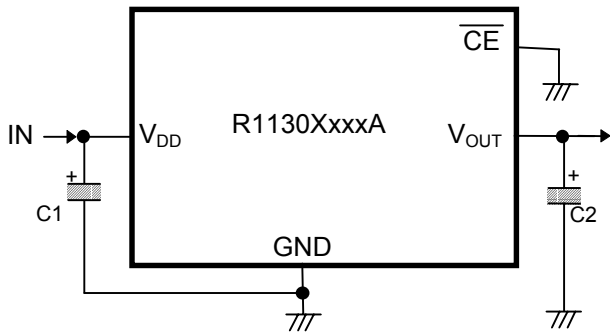

C1=C2=0.1μF

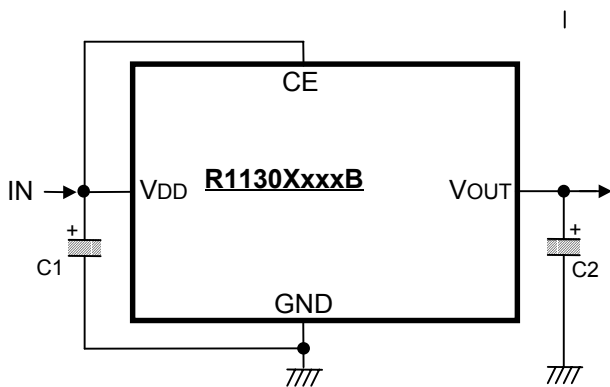

C1=C2=0.1μF

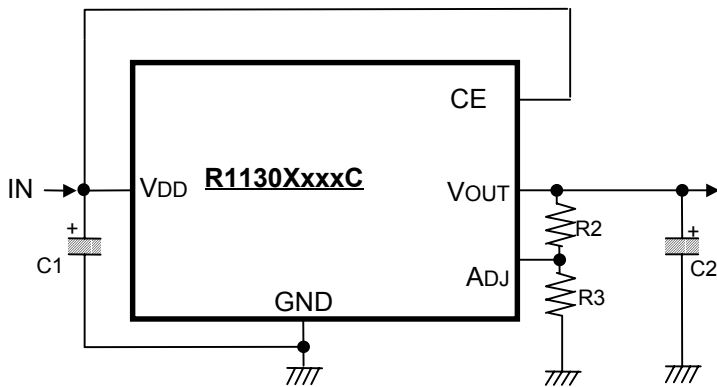

C1=C2=0.1μF, R2, R3: Refer to the Technical Notes on Output Voltage setting of C type.

■ TYPICAL CHARACTERISTICS

1) Output Voltage vs. Output Current (T_{opt}=25°C)

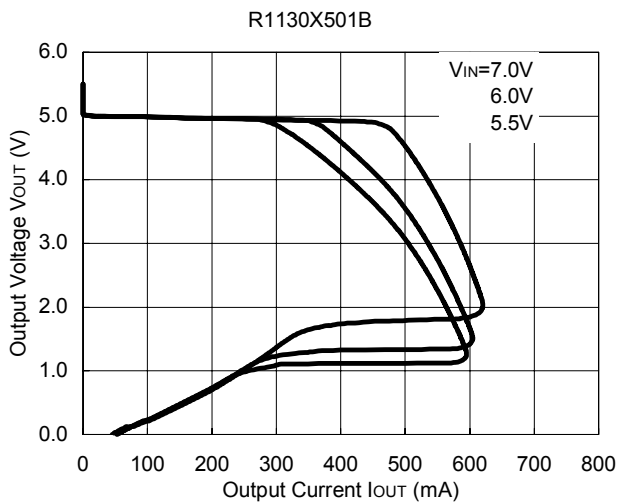
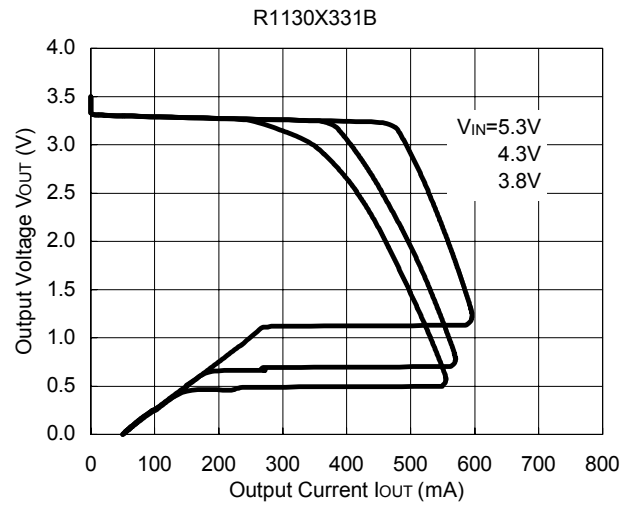
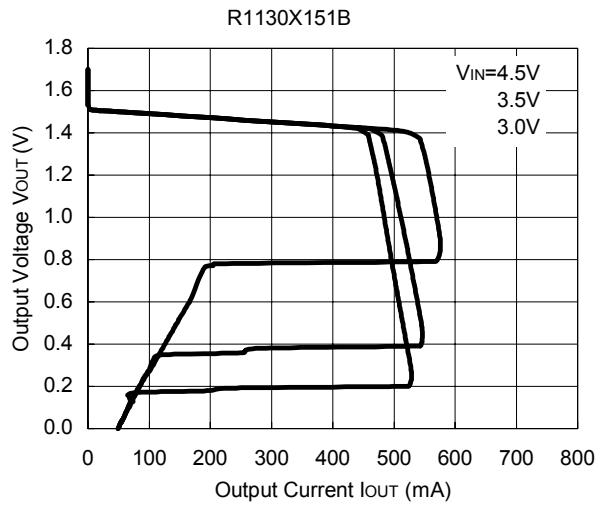

2) Input Voltage vs. Output Voltage (T_{opt}=25°C)

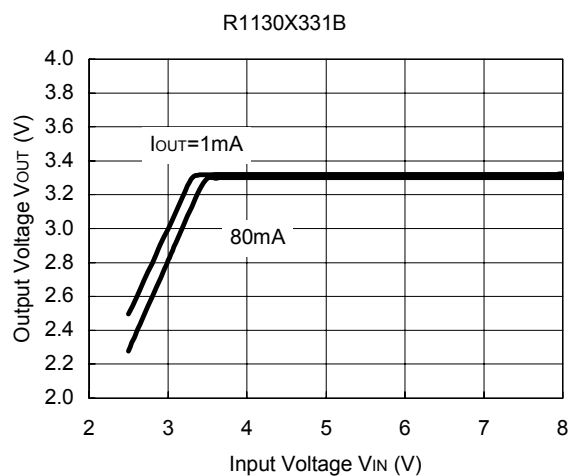
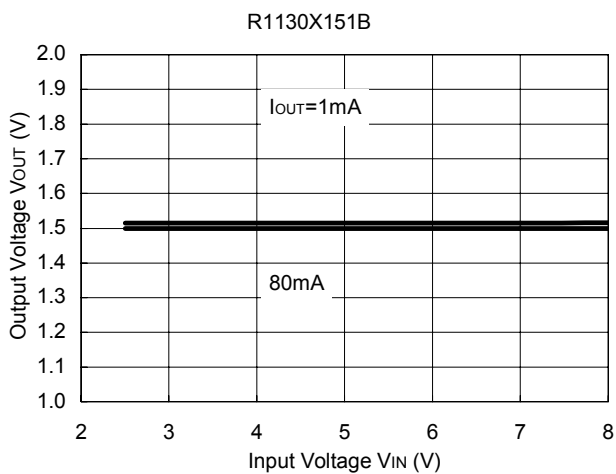

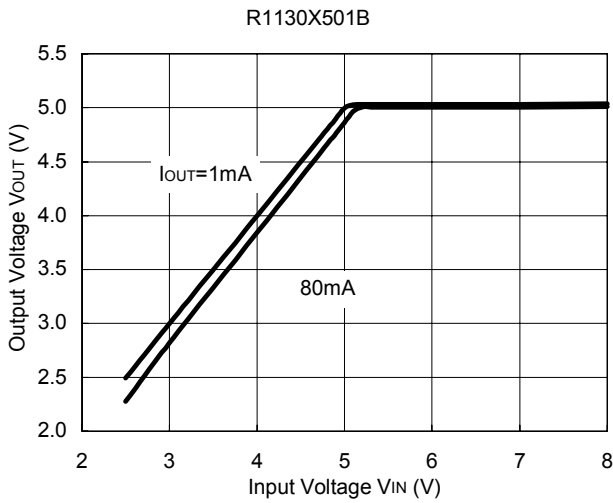

3) Dropout Voltage vs. Output Current

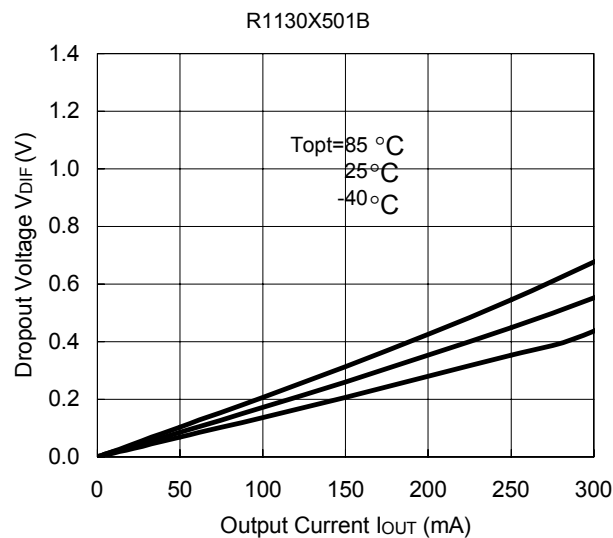
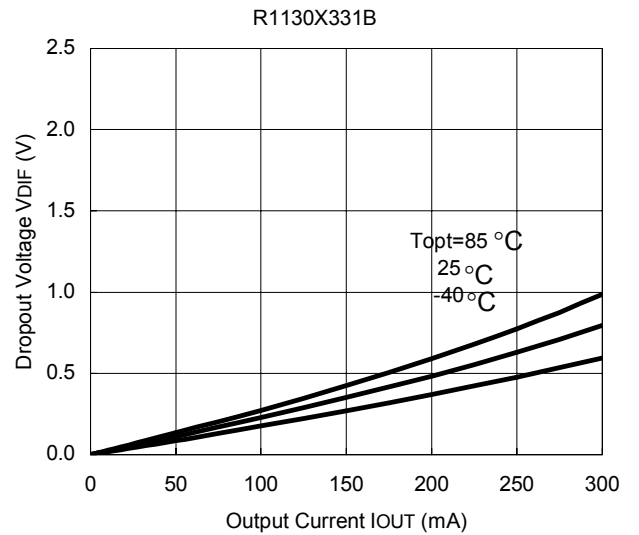
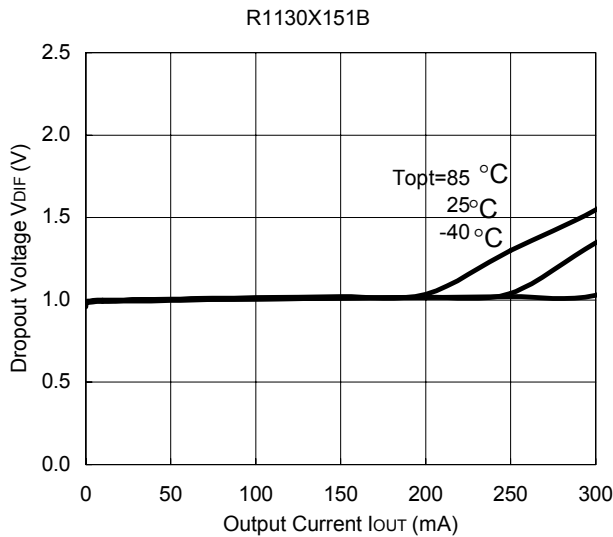

4) Output Voltage vs. Temperature

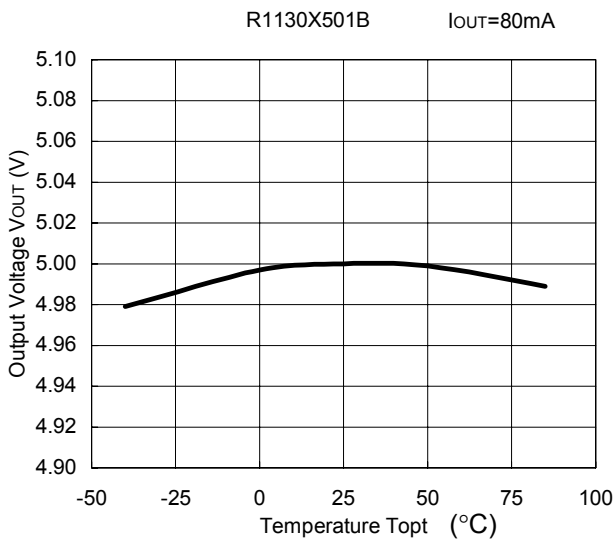
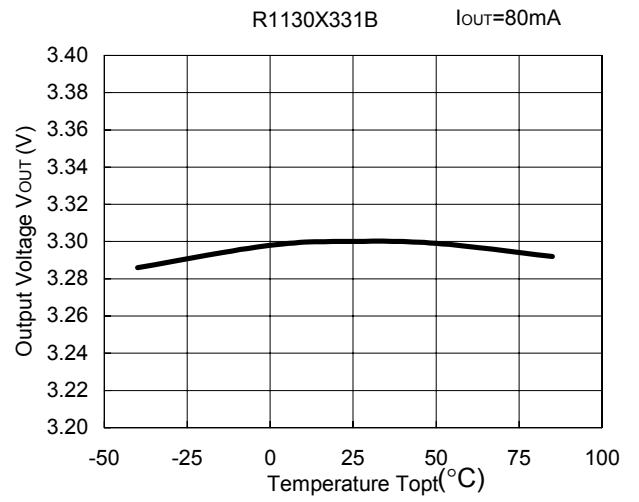
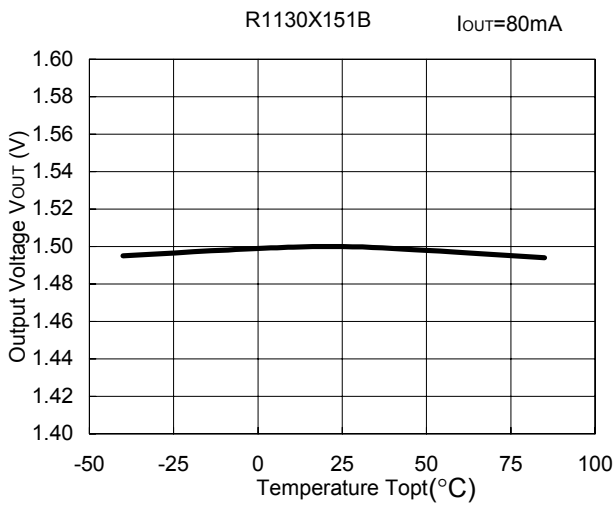

5) Supply Current vs. Input Voltage($T_{opt}=25^{\circ}C$)

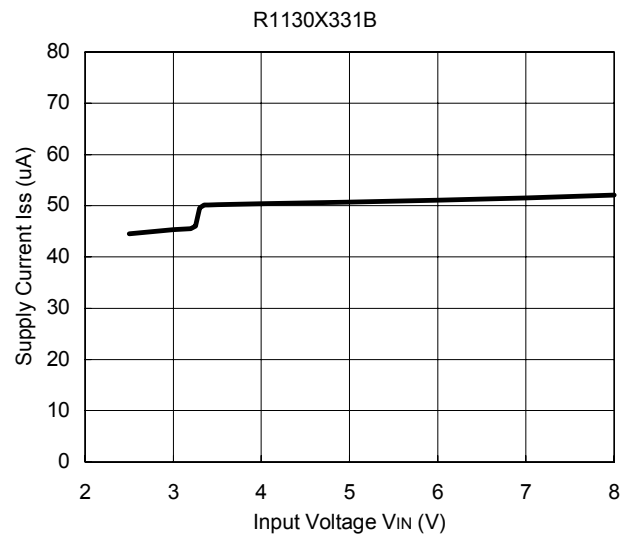
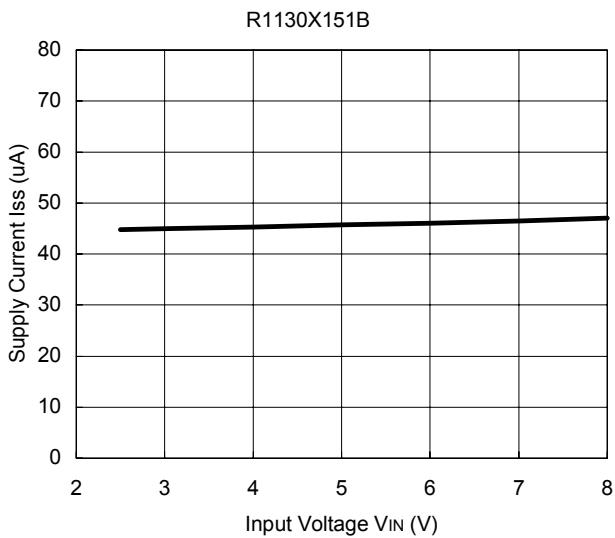

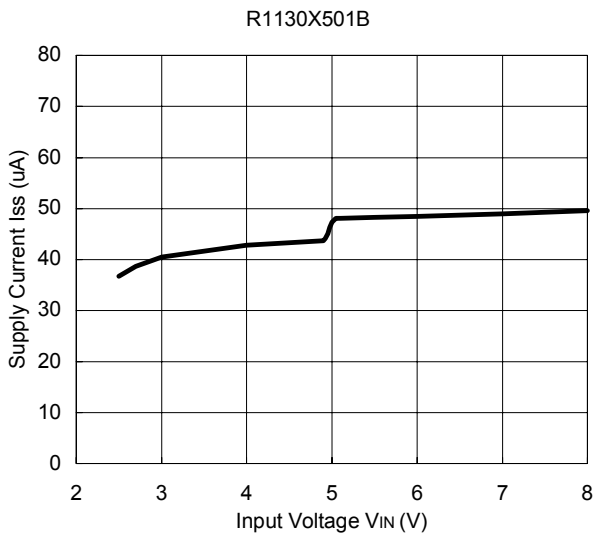

6) Supply Current vs. Temperature

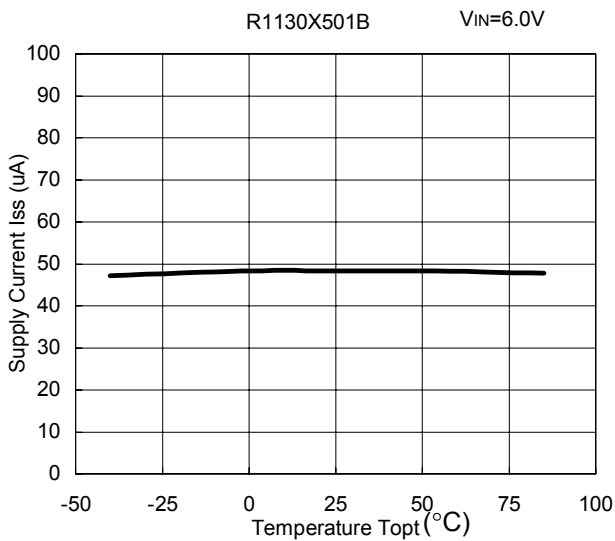
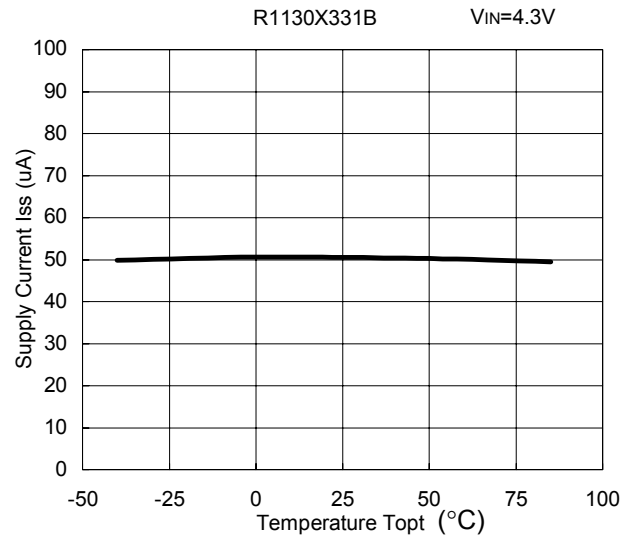
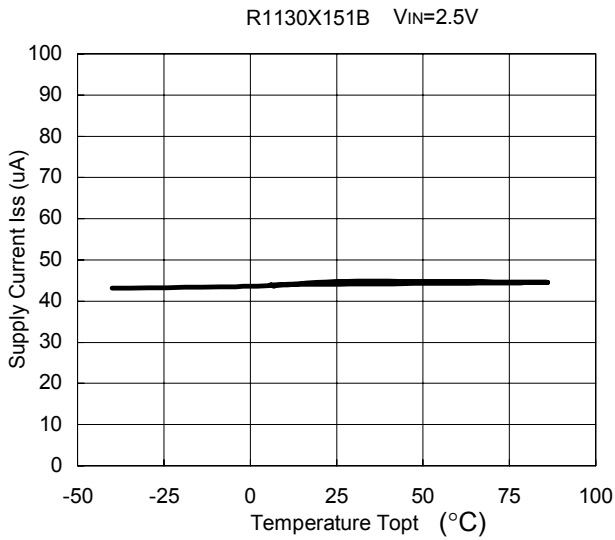

7) Ripple Rejection vs. Frequency

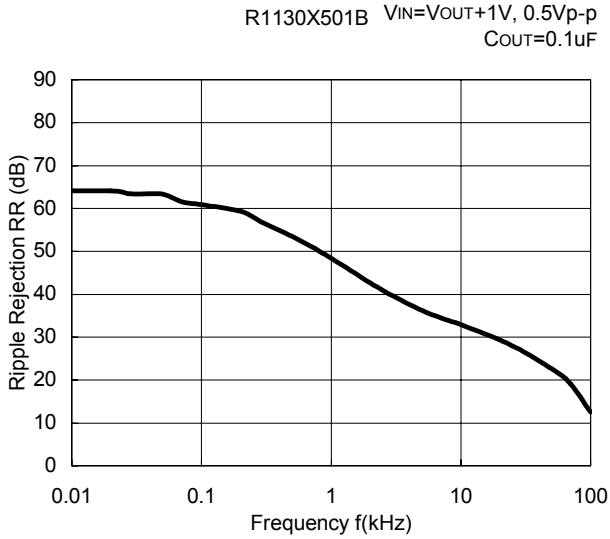
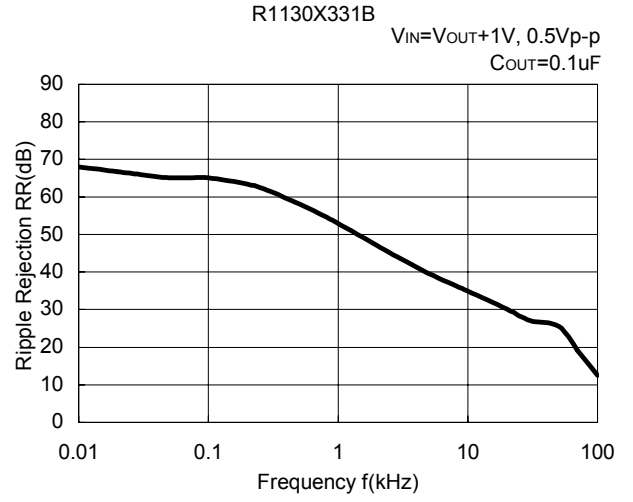
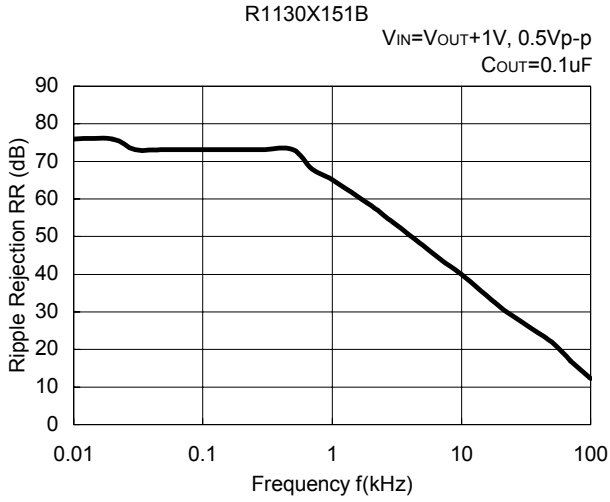

8) Ripple Rejection vs. Input Voltage

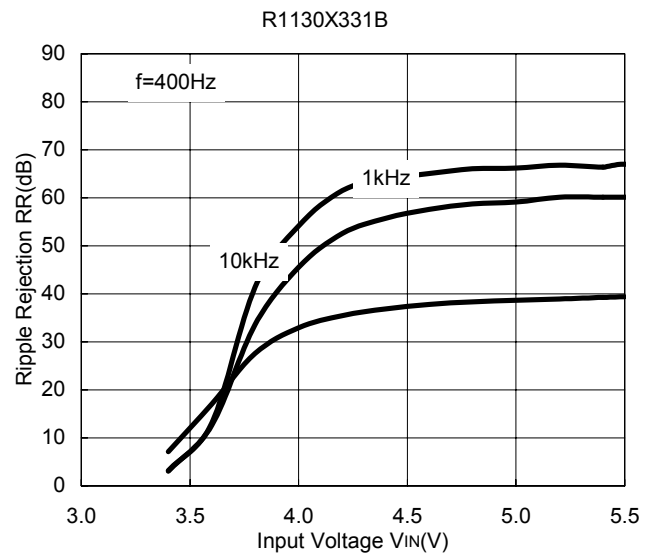
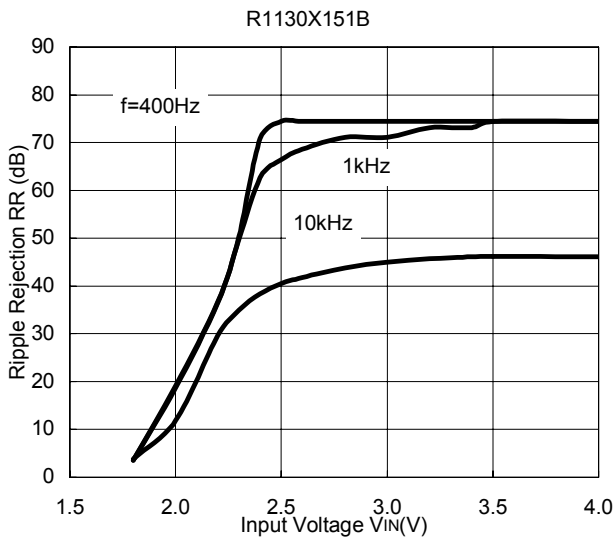

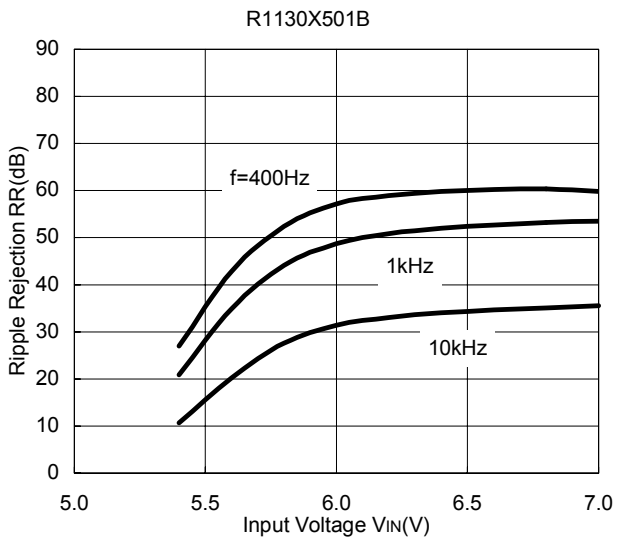

9) Input Transient Response

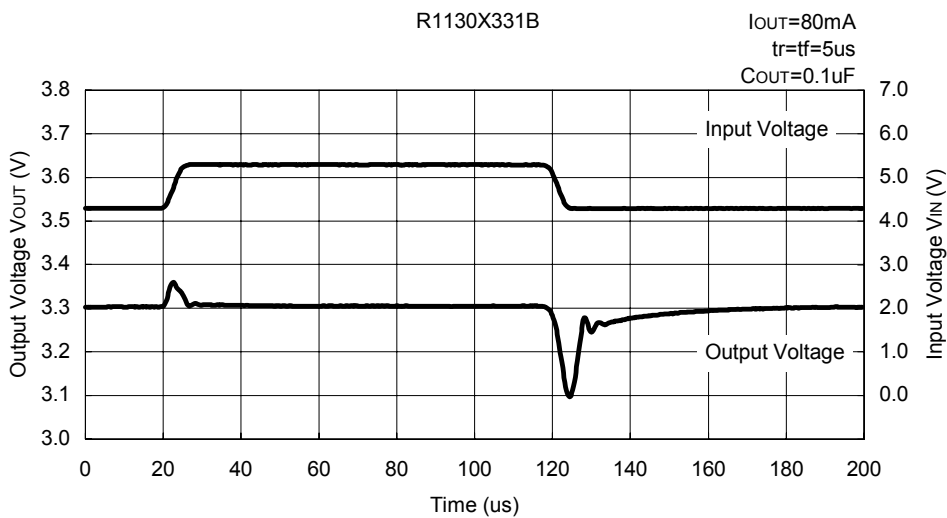
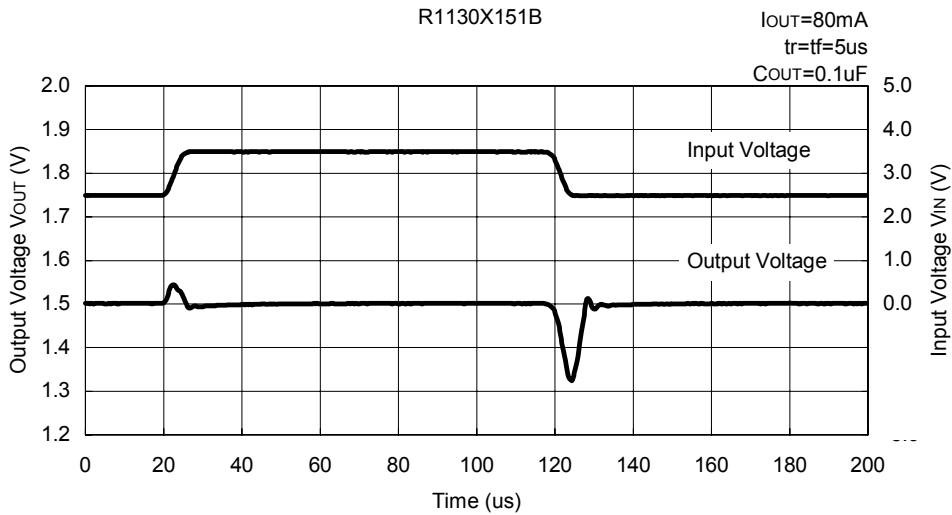

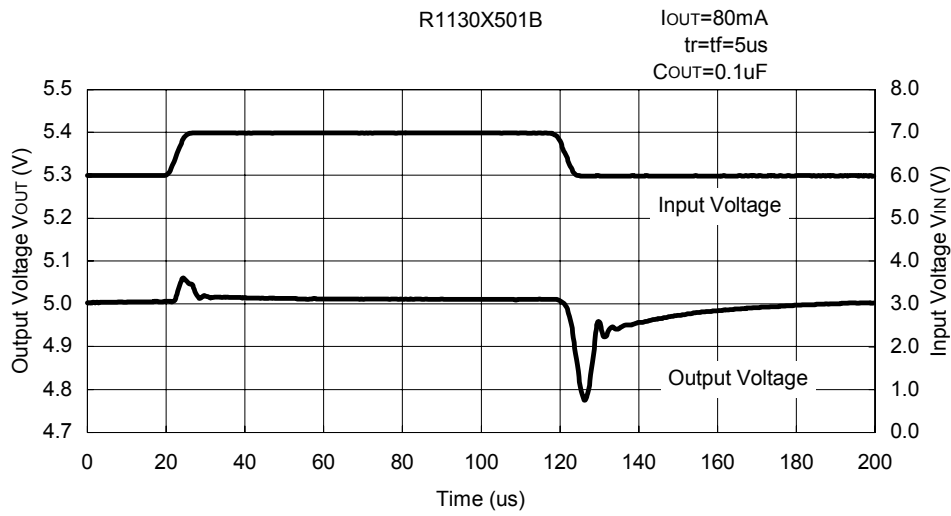

10) Load Transient Response

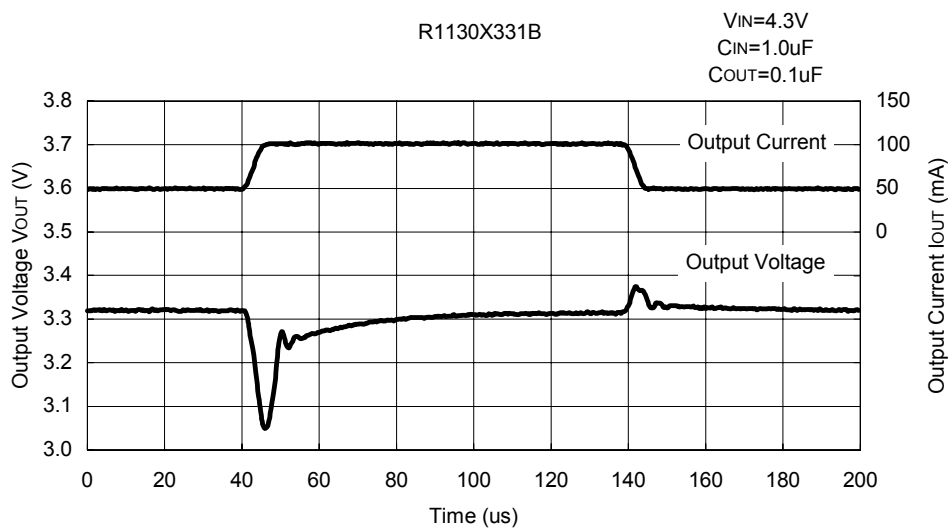
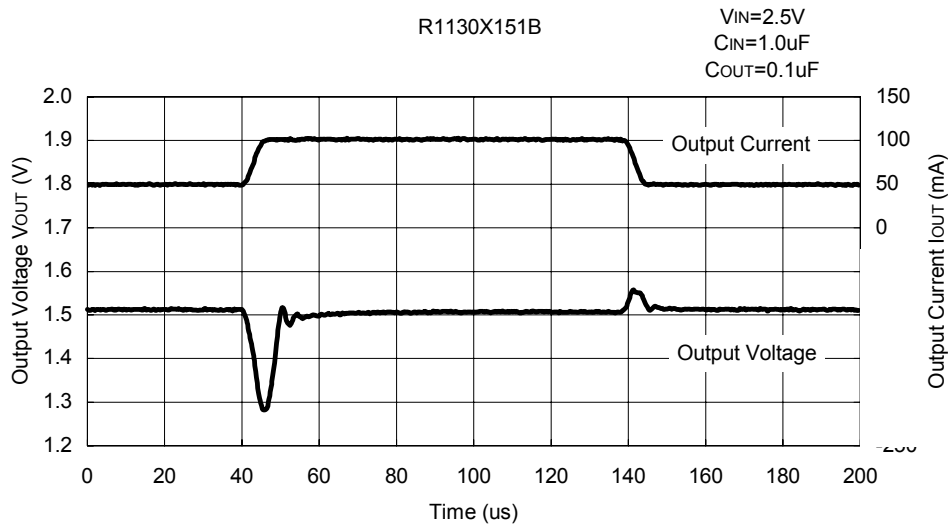

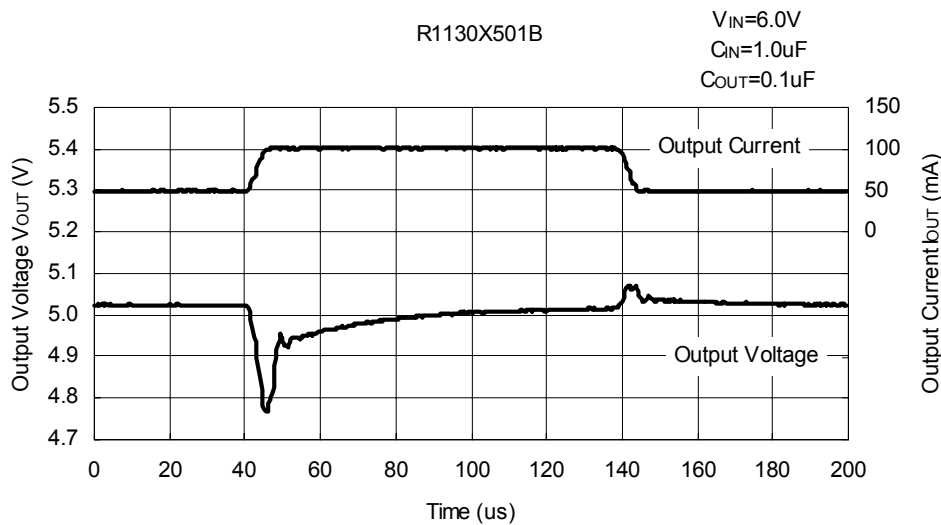

■ APPENDIX

* Technical Notes on Output Voltage Setting of C type

Figure 1. Adjustable Regulator (C type)

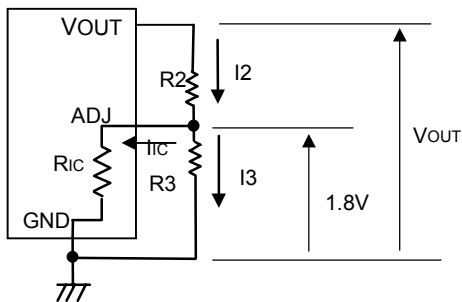

The Output Voltage of Regulator in R1130XXXXC may be adjustable for any output voltage between its 1.8V reference and its VDD setting level. An external pair of resistors is required, as shown in Figure 1.

The complete equation for the output voltage is described step by step as follows;

$$I_2 = I_{IC} + I_3 \quad \dots (1)$$

$$I_3 = 1.8/R_3 \quad \dots (2)$$

Thus,

$$I_2 = I_{IC} + 1.8/R_3 \quad \dots (3)$$

Therefore,

$$V_{OUT} = 1.8 + R_2 \times I_2 \quad \dots (4)$$

Put Equation (3) into Equation (4), then

$$\begin{aligned} V_{OUT} &= 1.8 + R_2 \times (I_{IC} + 1.8/R_3) \\ &= 1.8 \times (1 + R_2/R_3) + R_2 \times I_{IC} \quad \dots (5) \end{aligned}$$

In 2nd term, or $R_2 \times I_{IC}$ will produce an error in V_{OUT} .

In Equation (5),

$$I_{IC} = 1.8/R_{IC} \quad \dots (6)$$

$$R_2 \times I_{IC} = R_2 \times 1.8/R_{IC}$$

$$= 1.8 \times R_2/R_{IC} \quad \dots (7)$$

For better accuracy, choosing $R_2 \ll R_{IC}$ reduces this error.

* Adjustable Resister Dependence of Output Voltage

