

## 2MHz, Operational Transconductance Amplifier (OTA)

The CA3080 and CA3080A types are Gatable-Gain Blocks which utilize the unique operational-transconductance-amplifier (OTA) concept described in Application Note AN6668, "Applications of the CA3080 and CA3080A High-Performance Operational Transconductance Amplifiers".

The CA3080 and CA3080A types have differential input and a single-ended, push-pull, class A output. In addition, these types have an amplifier bias input which may be used either for gating or for linear gain control. These types also have a high output impedance and their transconductance ( $g_M$ ) is directly proportional to the amplifier bias current ( $I_{ABC}$ ).

The CA3080 and CA3080A types are notable for their excellent slew rate ( $50V/\mu s$ ), which makes them especially useful for multiplexer and fast unity-gain voltage followers. These types are especially applicable for multiplexer applications because power is consumed only when the devices are in the "ON" channel state.

The CA3080A's characteristics are specifically controlled for applications such as sample-hold, gain-control, multiplexing, etc.

### Ordering Information

PART NUMBER (BRAND)	TEMP. RANGE (°C)	PACKAGE	PKG. NO.
CA3080AE	-55 to 125	8 Ld PDIP	E8.3
CA3080AM (3080A)	-55 to 125	8 Ld SOIC	M8.15
CA3080AM96 (3080A)	-55 to 125	8 Ld SOIC Tape and Reel	M8.15
CA3080E	0 to 70	8 Ld PDIP	E8.3
CA3080M (3080)	0 to 70	8 Ld SOIC	M8.15
CA3080M96 (3080)	0 to 70	8 Ld SOIC Tape and Reel	M8.15

### Features

- Slew Rate (Unity Gain, Compensated) . . . . .  $50V/\mu s$
- Adjustable Power Consumption . . . . .  $10\mu W$  to  $30\mu W$
- Flexible Supply Voltage Range . . . . .  $\pm 2V$  to  $\pm 15V$
- Fully Adjustable Gain . . . . . 0 to  $g_{MR_L}$  Limit
- Tight  $g_M$  Spread:
  - CA3080 . . . . . 2:1
  - CA3080A . . . . . 1.6:1
- Extended  $g_M$  Linearity . . . . . 3 Decades

### Applications

- Sample and Hold
- Multiplexer
- Voltage Follower
- Multiplier
- Comparator

### Pinouts

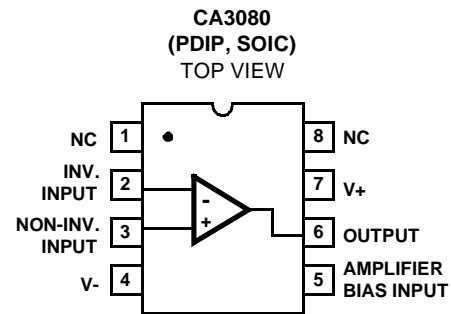

# CA3080, CA3080A

## Absolute Maximum Ratings

Supply Voltage (Between V+ and V- Terminal) . . . . .	36V
Differential Input Voltage . . . . .	5V
Input Voltage . . . . .	V+ to V-
Input Signal Current . . . . .	1mA
Amplifier Bias Current (I <sub>ABC</sub> ) . . . . .	2mA
Output Short Circuit Duration (Note 1) . . . . .	No Limitation

## Thermal Information

Thermal Resistance (Typical, Note 2)	$\theta_{JA}$ (°C/W)	$\theta_{JC}$ (°C/W)
PDIP Package . . . . .	130	N/A
SOIC Package . . . . .	170	N/A
Maximum Junction Temperature (Plastic Package) . . . . .	150°C	
Maximum Storage Temperature Range . . . . .	-65°C to 150°C	
Maximum Lead Temperature (Soldering 10s) . . . . .	300°C (SOIC - Lead Tips Only)	

## Operating Conditions

Temperature Range	
CA3080 . . . . .	0°C to 70°C
CA3080A . . . . .	-55°C to 125°C

*CAUTION: Stresses above those listed in "Absolute Maximum Ratings" may cause permanent damage to the device. This is a stress only rating and operation of the device at these or any other conditions above those indicated in the operational sections of this specification is not implied.*

### NOTES:

1. Short circuit may be applied to ground or to either supply.
2.  $\theta_{JA}$  is measured with the component mounted on an evaluation PC board in free air.

## Electrical Specifications For Equipment Design, V<sub>SUPPLY</sub> = ±15V, Unless Otherwise Specified

PARAMETER	TEST CONDITIONS	TEMP	CA3080			CA3080A			UNITS	
			MIN	TYP	MAX	MIN	TYP	MAX		
Input Offset Voltage	I <sub>ABC</sub> = 5µA	25	-	0.3	-	-	0.3	2	mV	
	I <sub>ABC</sub> = 500µA	25	-	0.4	5	-	0.4	2	mV	
		Full	-	-	6	-	-	5	mV	
Input Offset Voltage Change	I <sub>ABC</sub> = 500µA to 5µA	25	-	0.2	-	-	0.1	3	mV	
Input Offset Voltage Temp. Drift	I <sub>ABC</sub> = 100µA	Full	-	-	-	-	3.0	-	µV/°C	
Input Offset Voltage Sensitivity	Positive Negative	I <sub>ABC</sub> = 500µA	25	-	-	150	-	-	150	µV/V
			25	-	-	150	-	-	150	µV/V
Input Offset Current	I <sub>ABC</sub> = 500µA	25	-	0.12	0.6	-	0.12	0.6	µA	
Input Bias Current	I <sub>ABC</sub> = 500µA	25	-	2	5	-	2	5	µA	
		Full	-	-	7	-	-	15	µA	
Differential Input Current	I <sub>ABC</sub> = 0, V <sub>DIFF</sub> = 4V	25	-	0.008	-	-	0.008	5	nA	
Amplifier Bias Voltage	I <sub>ABC</sub> = 500µA	25	-	0.71	-	-	0.71	-	V	
Input Resistance	I <sub>ABC</sub> = 500µA	25	10	26	-	10	26	-	kΩ	
Input Capacitance	I <sub>ABC</sub> = 500µA, f = 1MHz	25	-	3.6	-	-	3.6	-	pF	
Input-to-Output Capacitance	I <sub>ABC</sub> = 500µA, f = 1MHz	25	-	0.024	-	-	0.024	-	pF	
Common-Mode Input-Voltage Range	I <sub>ABC</sub> = 500µA	25	12 to -12	13.6 to -14.6	-	12 to -12	13.6 to -14.6	-	V	
Forward Transconductance (Large Signal)	I <sub>ABC</sub> = 500µA	25	6700	9600	13000	7700	9600	12000	µS	
		Full	5400	-	-	4000	-	-	µS	
Output Capacitance	I <sub>ABC</sub> = 500µA, f = 1MHz	25	-	5.6	-	-	5.6	-	pF	
Output Resistance	I <sub>ABC</sub> = 500µA	25	-	15	-	-	15	-	MΩ	
Peak Output Current	I <sub>ABC</sub> = 5µA, R <sub>L</sub> = 0Ω	25	-	5	-	3	5	7	µA	
		25	350	500	650	350	500	650	µA	
		Full	300	-	-	300	-	-	µA	

# CA3080, CA3080A

## Electrical Specifications For Equipment Design, $V_{SUPPLY} = \pm 15V$ , Unless Otherwise Specified (Continued)

PARAMETER	TEST CONDITIONS	TEMP	CA3080			CA3080A			UNITS	
			MIN	TYP	MAX	MIN	TYP	MAX		
Peak Output Voltage	Positive	$I_{ABC} = 5\mu A, R_L = \infty$	25	-	13.8	-	12	13.8	-	V
	Negative		25	-	-14.5	-	-12	-14.5	-	V
	Positive	$I_{ABC} = 500\mu A, R_L = \infty$	25	12	13.5	-	12	13.5	-	V
	Negative		25	-12	-14.4	-	-12	-14.4	-	V
Amplifier Supply Current	$I_{ABC} = 500\mu A$	25	0.8	1	1.2	0.8	1	1.2	mA	
Device Dissipation	$I_{ABC} = 500\mu A$	25	24	30	36	24	30	36	mW	
Magnitude of Leakage Current	$I_{ABC} = 0, V_{TP} = 0$	25	-	0.08	-	-	0.08	5	nA	
	$I_{ABC} = 0, V_{TP} = 36V$	25	-	0.3	-	-	0.3	5	nA	
Propagation Delay	$I_{ABC} = 500\mu A$	25	-	45	-	-	45	-	ns	
Common-Mode Rejection Ratio	$I_{ABC} = 500\mu A$	25	80	110	-	80	110	-	dB	
Open-Loop Bandwidth	$I_{ABC} = 500\mu A$	25	-	2	-	-	2	-	MHz	
Slew Rate	Uncompensated	25	-	75	-	-	75	-	V/ $\mu s$	
	Compensated	25	-	50	-	-	50	-	V/ $\mu s$	

## Schematic Diagram

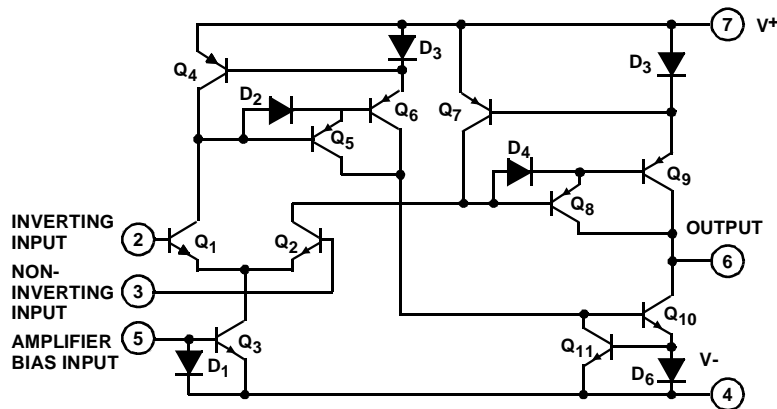

## Typical Applications

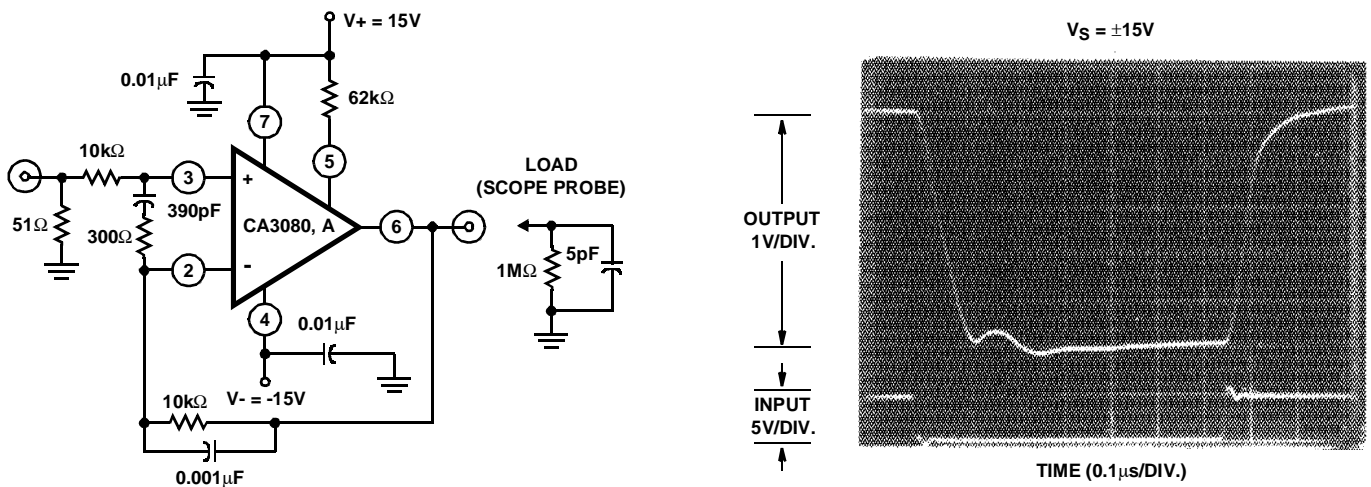

FIGURE 1. SCHEMATIC DIAGRAM OF THE CA3080 AND CA3080A IN A UNITY-GAIN VOLTAGE FOLLOWER CONFIGURATION AND ASSOCIATED WAVEFORM

Typical Applications (Continued)

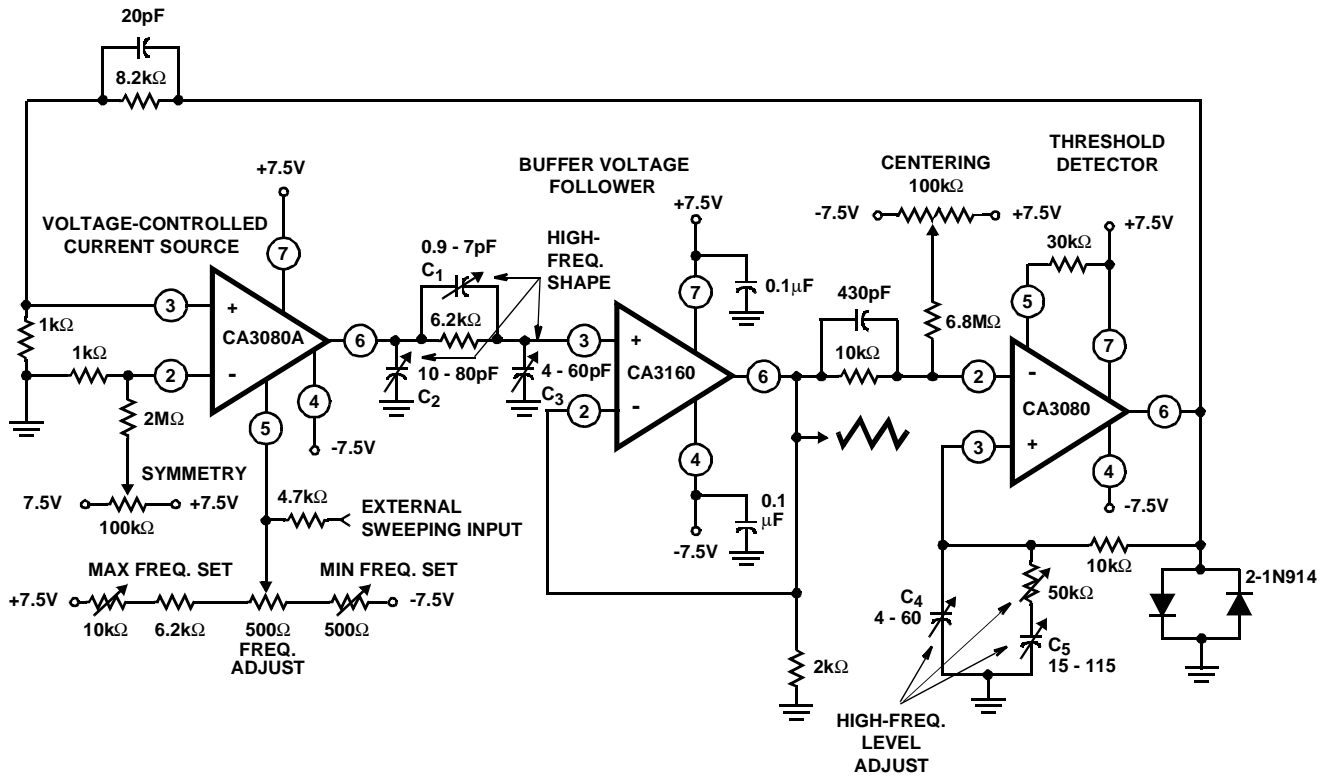
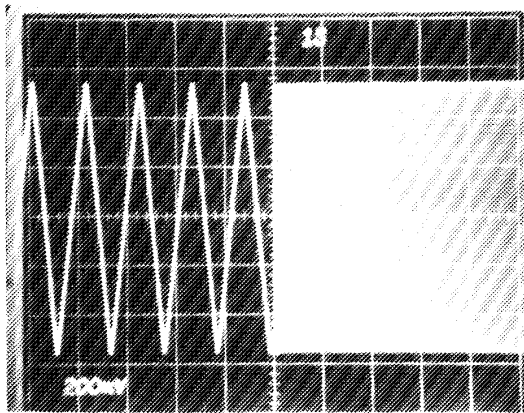
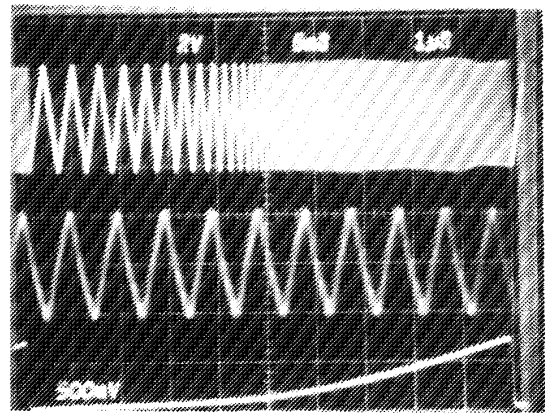

FIGURE 2. 1,000,000/1 SINGLE-CONTROL FUNCTION GENERATOR - 1MHz TO 1Hz



NOTE: A Square-Wave Signal Modulates The External Sweeping Input to Produce 1Hz and 1MHz, showing the 1,000,000/1 frequency range of the function generator.

FIGURE 3A. TWO-TONE OUTPUT SIGNAL FROM THE FUNCTION GENERATOR



NOTE: The bottom trace is the sweeping signal and the top trace is the actual generator output. The center trace displays the 1MHz signal via delayed oscilloscope triggering of the upper swept output signal.

FIGURE 3B. TRIPLE-TRACE OF THE FUNCTION GENERATOR SWEEPING TO 1MHz

FIGURE 3. FUNCTION GENERATOR DYNAMIC CHARACTERISTICS WAVEFORMS

Typical Applications (Continued)

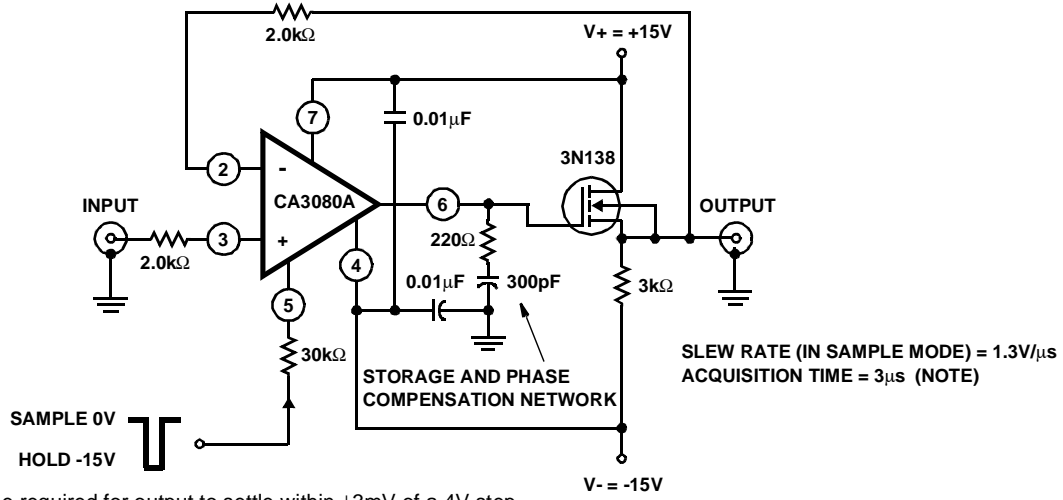

FIGURE 4. SCHEMATIC DIAGRAM OF THE CA3080A IN A SAMPLE-HOLD CONFIGURATION

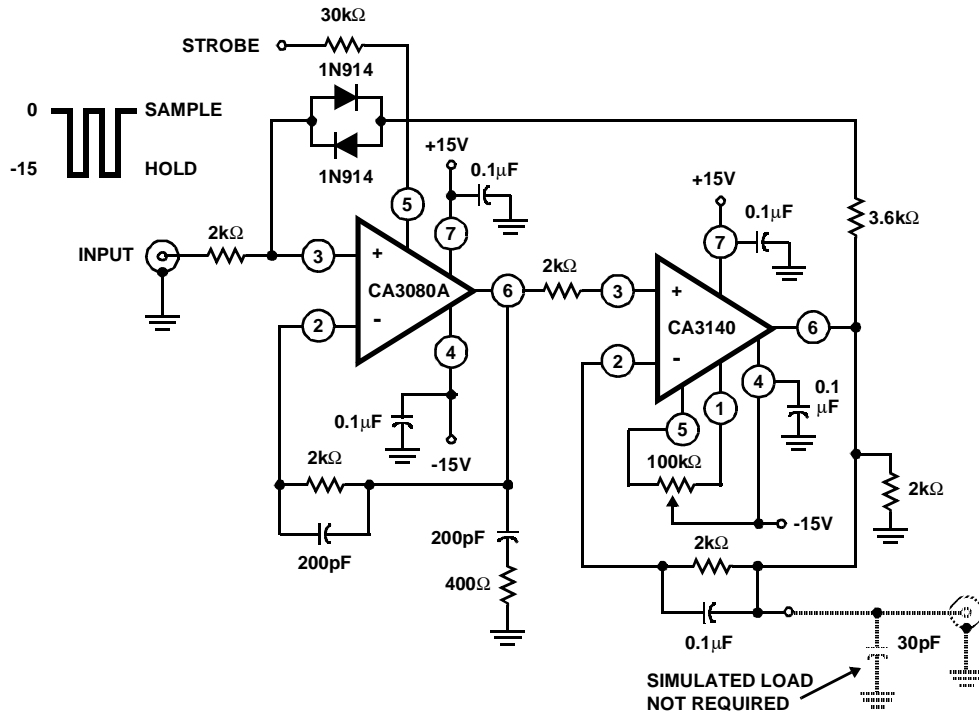
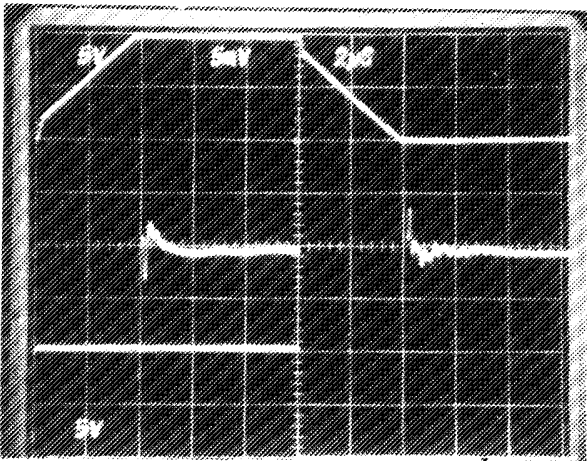

FIGURE 5. SAMPLE AND HOLD CIRCUIT

Typical Applications (Continued)



Top Trace: Output Signal  
5V/Div., 2 $\mu$ s/Div.  
Bottom Trace: Input Signal  
5V/Div., 2 $\mu$ s/Div.  
Center Trace: Difference of Input and Output Signals Through  
Tektronix Amplifier 7A13  
5mV/Div., 2 $\mu$ s/Div.

FIGURE 6. LARGE SIGNAL RESPONSE AND SETTLING TIME FOR CIRCUIT SHOWN IN FIGURE 5

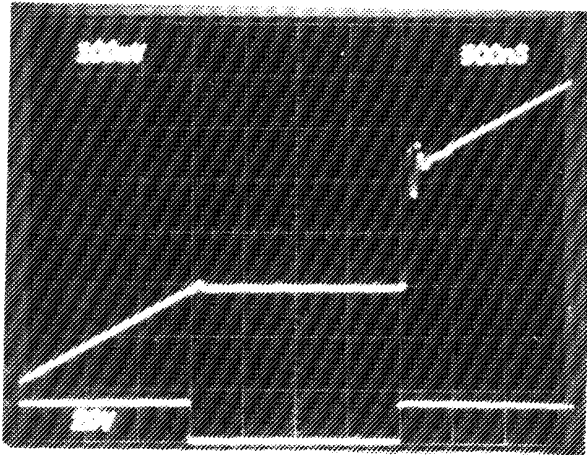

Top Trace: System Output; 100mV/Div., 500ns/Div.  
Bottom Trace: Sampling Signal; 20V/Div., 500ns/Div.

FIGURE 7. SAMPLING RESPONSE FOR CIRCUIT SHOWN IN FIGURE 5

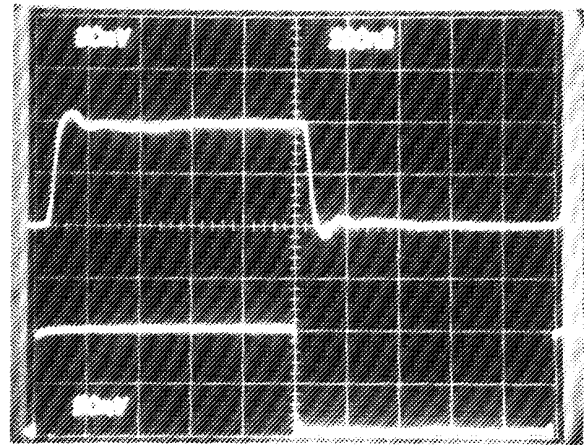

Top Trace: Output; 50mV/Div., 200ns/Div.  
Bottom Trace: Input; 50mV/Div., 200ns/Div.

FIGURE 8. INPUT AND OUTPUT RESPONSE FOR CIRCUIT SHOWN IN FIGURE 5

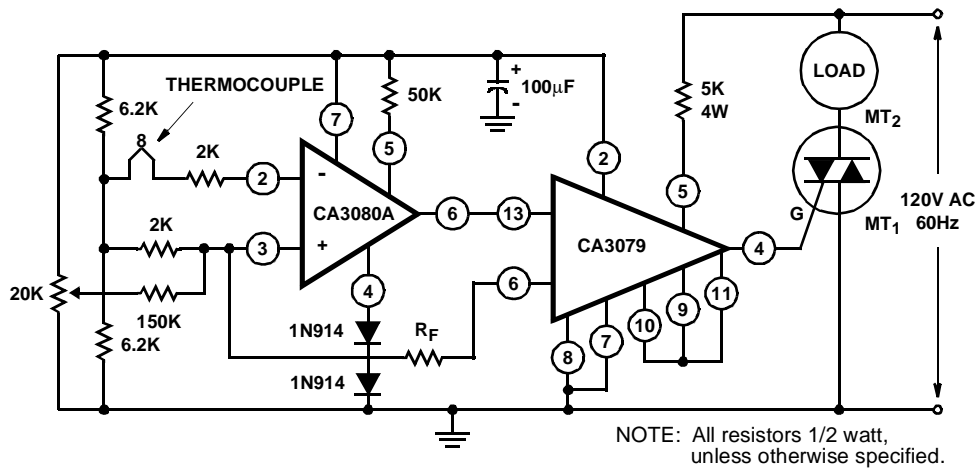

FIGURE 9. THERMOCOUPLE TEMPERATURE CONTROL WITH CA3079 ZERO VOLTAGE SWITCH AS THE OUTPUT AMPLIFIER

Typical Applications (Continued)

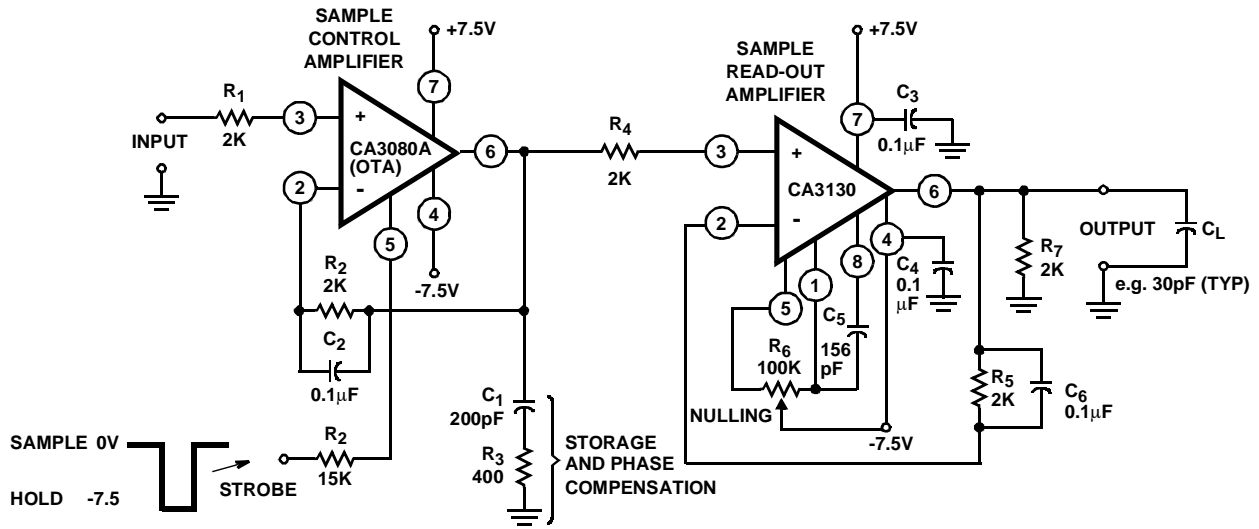
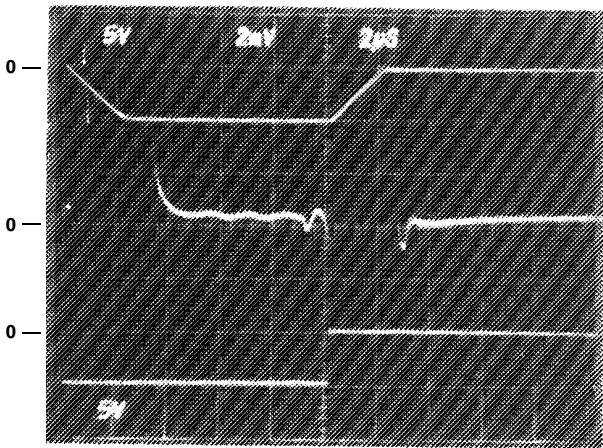
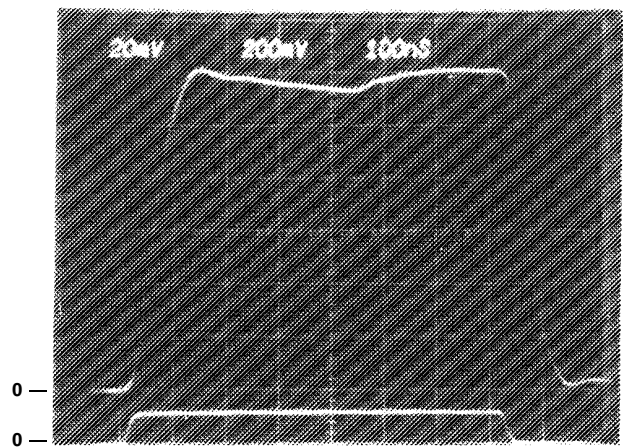

FIGURE 10. SCHEMATIC DIAGRAM OF THE CA3080A IN A SAMPLE-HOLD CIRCUIT WITH BIMOS OUTPUT AMPLIFIER



Top Trace: Output; 5V/Div., 2µs/Div.  
 Center Trace: Differential Comparison of Input and Output  
 2mV/Div., 2µs/Div.  
 Bottom Trace: Input; 5V/Div., 2µs/Div.

FIGURE 11. LARGE-SIGNAL RESPONSE FOR CIRCUIT SHOWN IN FIGURE 10



Top Trace: Output  
 20mV/Div., 100ns/Div.  
 Bottom Trace: Input  
 200mV/Div., 100ns/Div.

FIGURE 12. SMALL-SIGNAL RESPONSE FOR CIRCUIT SHOWN IN FIGURE 10

Typical Applications (Continued)

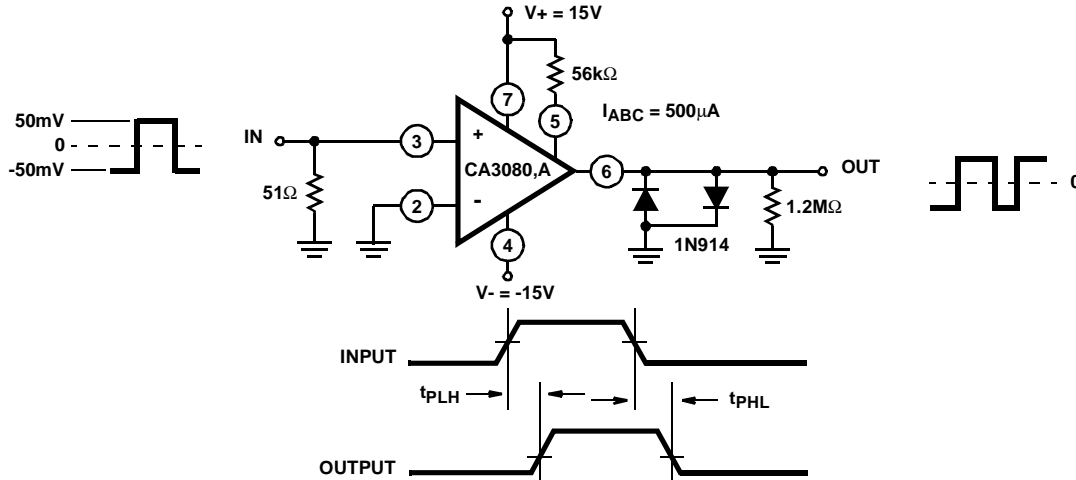

FIGURE 13. PROPAGATION DELAY TEST CIRCUIT AND ASSOCIATED WAVEFORMS

Typical Performance Curves

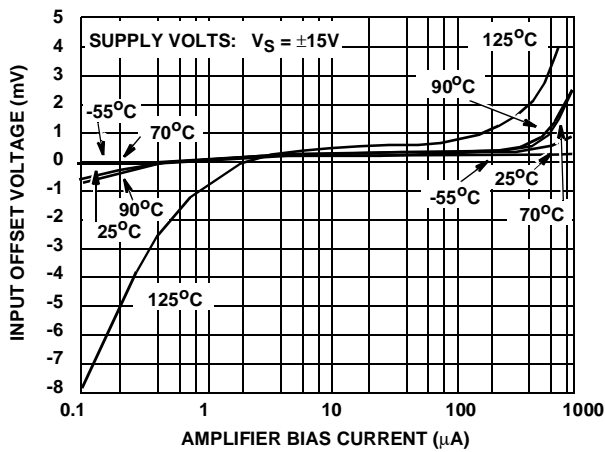

FIGURE 14. INPUT OFFSET VOLTAGE vs AMPLIFIER BIAS CURRENT

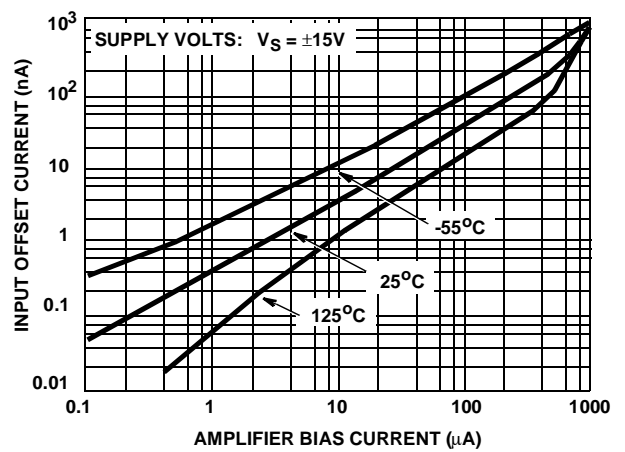

FIGURE 15. INPUT OFFSET CURRENT vs AMPLIFIER BIAS CURRENT

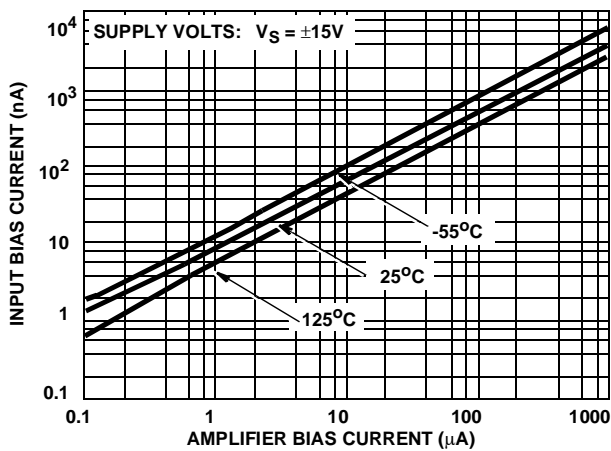

FIGURE 16. INPUT BIAS CURRENT vs AMPLIFIER BIAS CURRENT

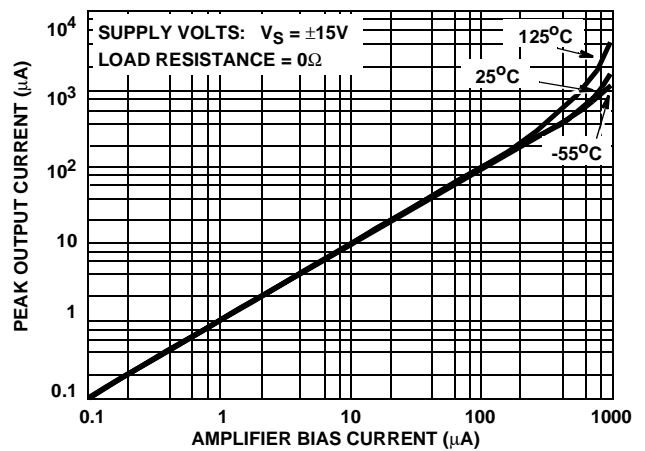

FIGURE 17. PEAK OUTPUT CURRENT vs AMPLIFIER BIAS CURRENT



Typical Performance Curves (Continued)

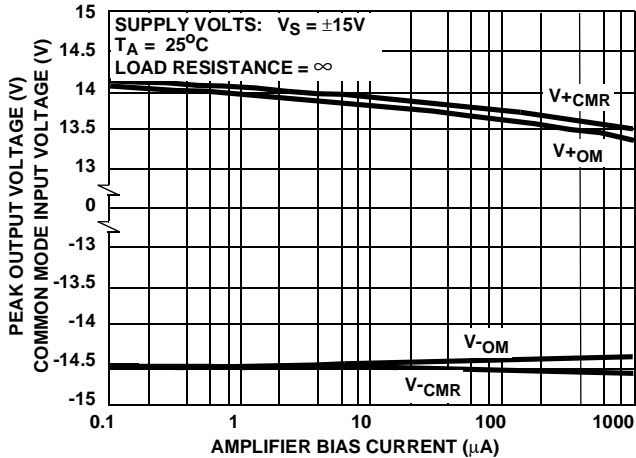

FIGURE 18. PEAK OUTPUT VOLTAGE vs AMPLIFIER BIAS CURRENT

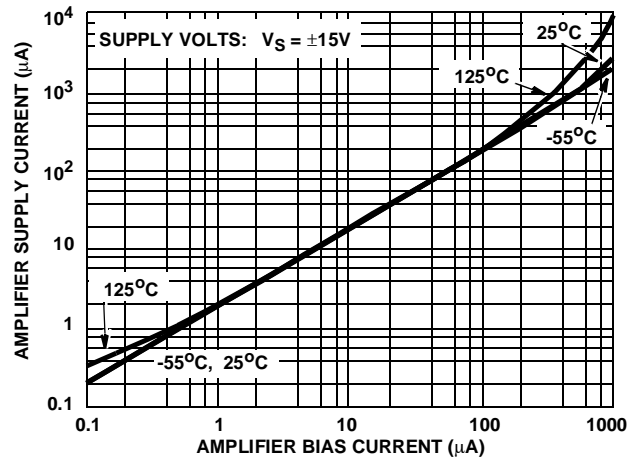

FIGURE 19. AMPLIFIER SUPPLY CURRENT vs AMPLIFIER BIAS CURRENT

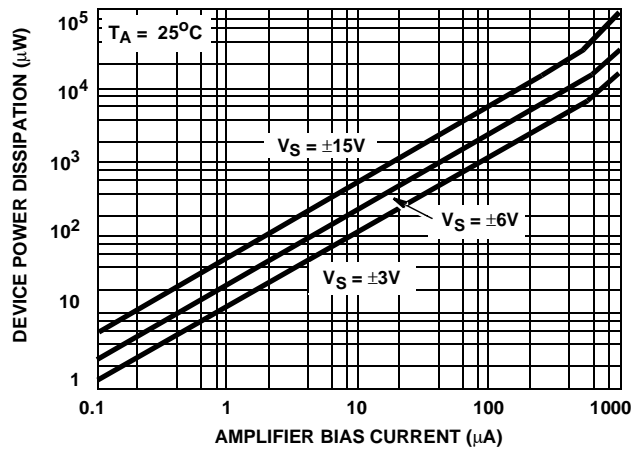

FIGURE 20. TOTAL POWER DISSIPATION vs AMPLIFIER BIAS CURRENT

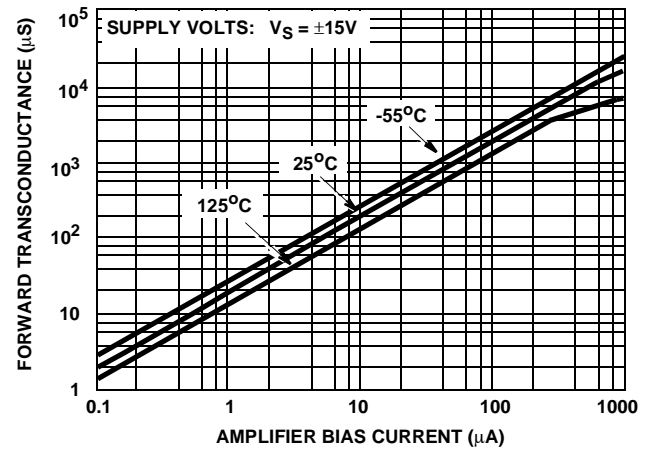

FIGURE 21. TRANSCONDUCTANCE vs AMPLIFIER BIAS CURRENT

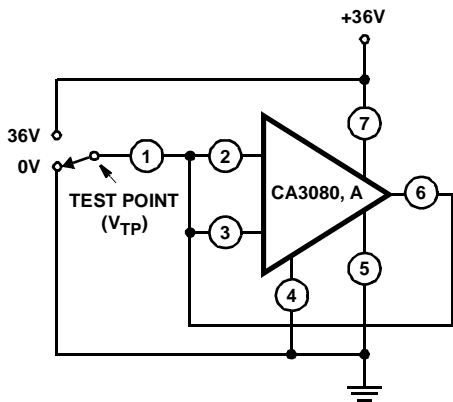

FIGURE 22. LEAKAGE CURRENT TEST CIRCUIT

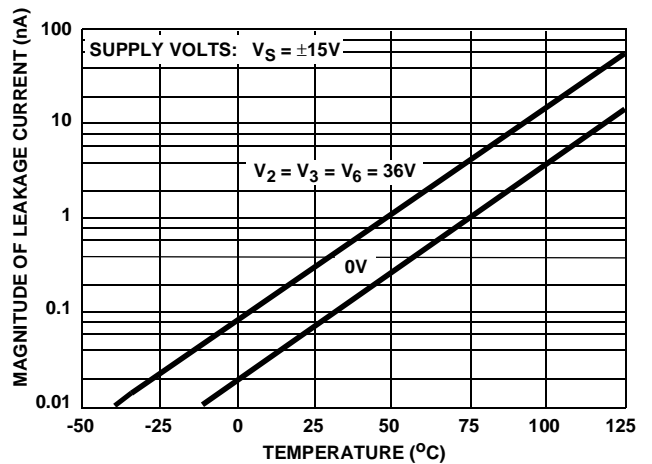

FIGURE 23. LEAKAGE CURRENT vs TEMPERATURE

Typical Performance Curves (Continued)

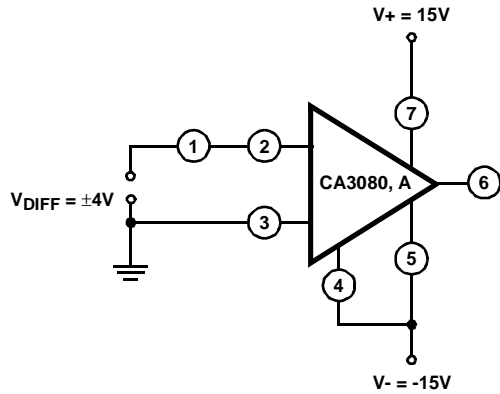

FIGURE 24. DIFFERENTIAL INPUT CURRENT TEST CIRCUIT

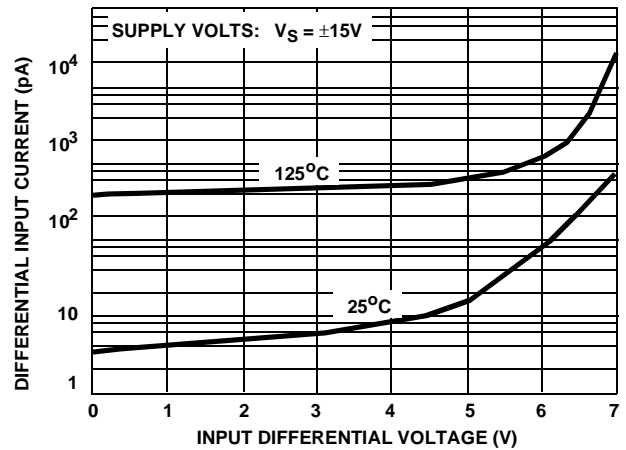

FIGURE 25. INPUT CURRENT vs INPUT DIFFERENTIAL VOLTAGE

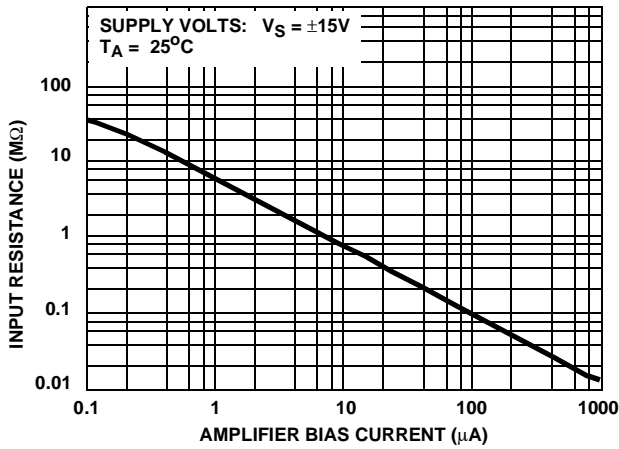

FIGURE 26. INPUT RESISTANCE vs AMPLIFIER BIAS CURRENT

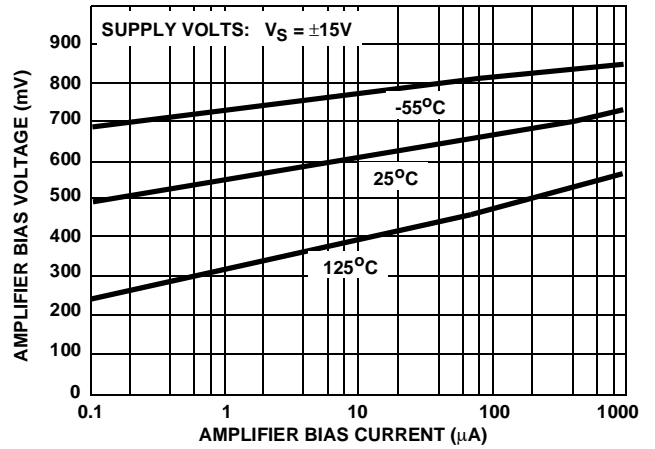

FIGURE 27. AMPLIFIER BIAS VOLTAGE vs AMPLIFIER BIAS CURRENT

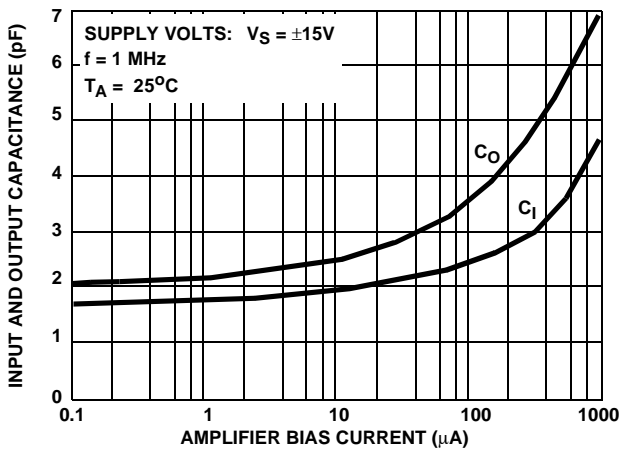

FIGURE 28. INPUT AND OUTPUT CAPACITANCE vs AMPLIFIER BIAS CURRENT

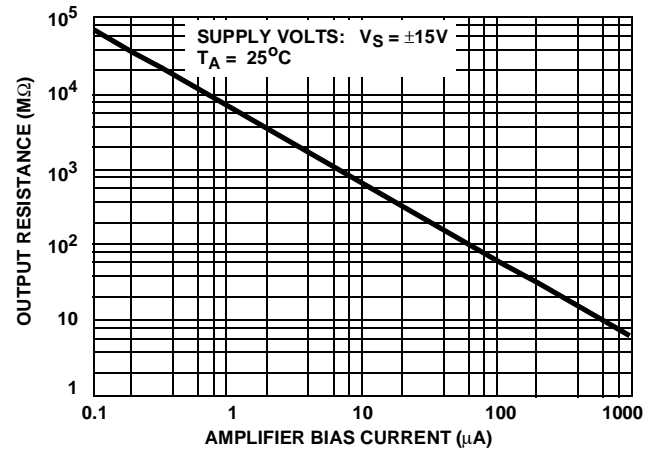

FIGURE 29. OUTPUT RESISTANCE vs AMPLIFIER BIAS CURRENT

Typical Performance Curves (Continued)

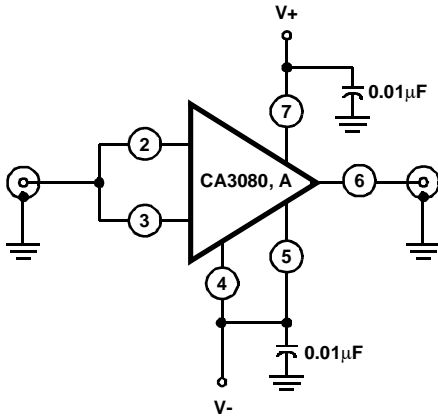

FIGURE 30. INPUT-TO-OUTPUT CAPACITANCE TEST CIRCUIT

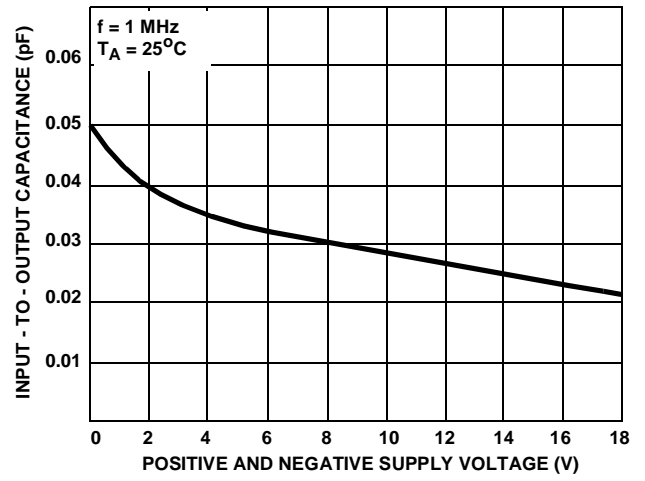

FIGURE 31. INPUT-TO-OUTPUT CAPACITANCE vs SUPPLY VOLTAGE