

Adjustable Precision Shunt Regulator

FEATURES

- Precision Reference Voltage.
AIC431 :2.495V $\pm 0.5\%$
TL431A :2.495V $\pm 1.0\%$
TL431 :2.495V $\pm 1.6\%$
- Sink Current Capability: 200mA.
- Minimum Cathode Current for Regulation: 250 μ A.
- Equivalent Full-Range Temperature Coefficient: 50 ppm/ $^{\circ}$ C.
- Fast Turn-On Response.
- Low Dynamic Output Impedance: 0.08 Ω .
- Adjustable Output Voltage.
- Low Output Noise.
- Space Saving Packages: SOT-89, SOT-23, TO-92 and SO-8.

APPLICATIONS

- Linear Regulators.
- Adjustable Supplies.
- Switching Power Supplies.
- Battery Operated Computers.
- Instrumentation.
- Computer Disk Drivers.

DESCRIPTION

The AIC431, TL431A and TL431 are 3-terminal adjustable precision shunt regulators with guaranteed temperature stability over the applicable extended commercial temperature range. The output voltage may be set at any level greater than 2.495V (V_{REF}) up to 30V merely by selecting two external resistors that act as a voltage divider network. These devices have a typical output impedance of 0.08 Ω . Active output circuitry provides a very sharp turn-on characteristics, making these devices excellent improved replacements for zener diodes in many applications.

The precise $\pm 0.5\%$ reference voltage tolerance of the AIC431 makes it possible in many applications to avoid the use of a variable resistor, consequently saving cost and eliminating drift and reliability problems associated with it.

TYPICAL APPLICATION CIRCUIT

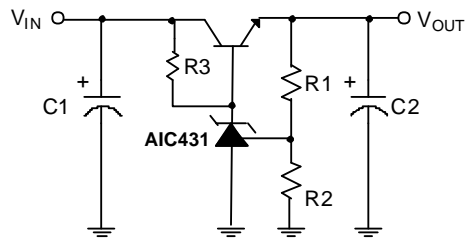

$$V_{OUT} = (1 + R1/R2)V_{REF}$$

Precision Regulator

ORDERING INFORMATION

AIC431 CXXX
 TL431A CXXX
 TL431 CXXX

PACKING TYPE
 TR: TAPE & REEL
 TB: TUBE (for SO-8)
 BG: BAG

PACKAGE TYPE
 S: SMALL OUTLINE
 US: SOT-23
 UN: SOT-23
 X: SOT-89
 Z: TO-92

Example: AIC431CSTR
 → in SO-8 Package & Taping & Reel Packing Type (CS is not available in BAG packing type.)

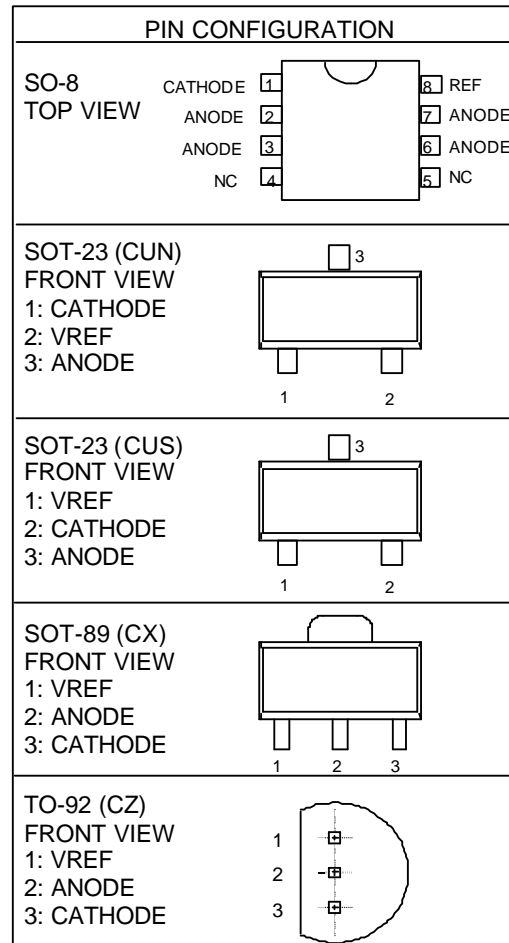

ABSOLUTE MAXIMUM RATINGS

Cathode Voltage30V
Continuous Cathode Current -10mA ~ 250mA
Reference Input Current Range 10mA
Operating Temperature Range, T _A -40°C ~ 85°C
Lead Temperature 260°C
Storage Temperature -65°C ~ 150°C
Power Dissipation (Notes 1, 2)	SOT-89 Package 0.80W
	TO-92 Package 0.78W

Note 1: T_{J, max} = 150°C.

Note 2: Ratings apply to ambient temperature at 25°C.

TEST CIRCUITS

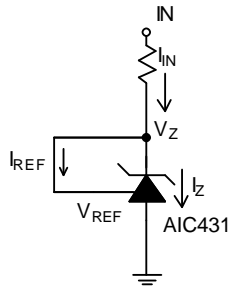
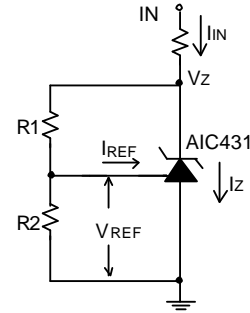

Fig. 1 Test Circuit for $V_Z = V_{REF}$



Note: $V_Z = V_{REF}(1 + R1/R2) + I_{REF} \times R1$

Fig. 2 Test Circuit for $V_Z > V_{REF}$

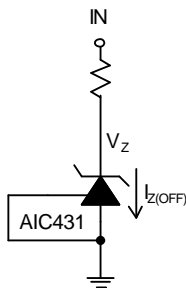

Fig. 3 Test Circuit for off-state Current

ELECTRICAL CHARACTERISTICS ($T_A = 25^\circ\text{C}$, unless otherwise specified.)

PARAMETER	TEST CONDITIONS	SYMBOL	MIN.	TYP.	MAX.	UNIT
Reference Voltage	$V_Z = V_{REF}$, $I_{IN} = 10\text{mA}$ (Fig. 1)	AIC431	2.482	2.495	2.508	V
		TL431A	2.470	2.495	2.520	
		TL431	2.455	2.495	2.535	
Deviation of Reference Input Voltage Over Temperature (Note 3)	$V_Z = V_{REF}$, $I_{IN} = 10\text{mA}$, $T_A = 0^\circ\text{C} \sim +70^\circ\text{C}$ (Fig. 1) $T_A = -40^\circ\text{C} \sim +85^\circ\text{C}$ (Fig. 1)	V_{DEV}		9.0	20	mV
				9.0	50	
Ratio of the Change in Reference Voltage to the Change in Cathode voltage	$I_Z = 10\text{mA}$ (Fig. 2)	$\Delta V_Z = 10\text{V} - V_{REF}$	$\frac{\Delta V_{REF}}{\Delta V_Z}$	-0.5	-2.0	mV/V
		$\Delta V_Z = 30\text{V} - 10\text{V}$	$\frac{\Delta V_{REF}}{\Delta V_Z}$	-0.35	-1.5	mV/V

ELECTRICAL CHARACTERISTICS (Continued)

PARAMETER	TEST CONDITIONS	SYMBOL	MIN.	TYP.	MAX.	UNIT
Reference Input Current	R1 =10KΩ, R2=∞, I _{IN} =10mA (Fig. 2)	I _{REF}		0.8	3.5	μA
Deviation of Reference Input Current over Temperature	R1 =10KΩ, R2=∞, I _{IN} =10mA T _A =-40°C ~ +85°C (Fig. 2)	αI _{REF}		0.3	1.2	μA
Minimum Cathode current for Regulation	V _Z =V _{REF} (Fig. 1)	I _{Z(MIN)}		0.25	0.5	mA
Off-State Current	V _Z =20V, V _{REF} =0V (Fig. 3)	I _{Z(OFF)}		0.1	1.0	μA
Dynamic Output Impedance (Note 4)	V _Z =V _{REF} F<1KHz (Fig. 1)	R _Z		0.08	0.3	Ω

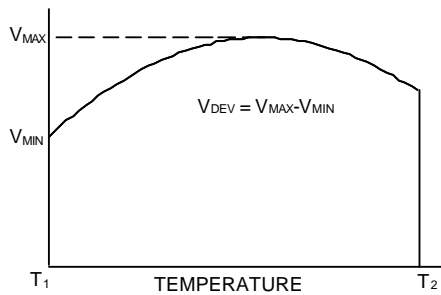

Note 3. Deviation of reference input voltage, V_{DEV}, is defined as the maximum variation of the reference input voltage over the full temperature range.

The average temperature coefficient of the reference input voltage, αV_{REF} is defined as:

$$\Delta V_{REF} \frac{\text{ppm}}{^{\circ}\text{C}} = \pm \left[\frac{V_{MAX} - V_{MIN}}{V_{REF}(\text{at } 25^{\circ}\text{C})} \right] 10^6 = \pm \left[\frac{V_{DEV}}{V_{REF}(\text{at } 25^{\circ}\text{C})} \right] 10^6$$

Where:

T₂-T₁=full temperature change.

αV_{REF} can be positive or negative depending on whether the slope is positive or negative.

Example: V_{DEV}= 9.0mV, V_{REF}= 2495mV,

T₂-T₁= 70°C, slope is negative.

$$aV_{REF} = \frac{\left[\frac{9.0\text{mV}}{2495\text{mV}} \right] 10^6}{70^{\circ}\text{C}} = -50\text{ppm}/^{\circ}\text{C}$$

Note 4. The dynamic output impedance, R_Z, is defined as:

$$R_Z = \frac{\Delta V_Z}{\Delta I_Z}$$

When the device is programmed with two external resistors, R₁ and R₂, (see Fig. 2), the dynamic output impedance of the overall circuit, is defined as:

$$r_z = \frac{\Delta V}{\Delta I} \cong R_Z \left[1 + \frac{R_1}{R_2} \right]$$

TYPICAL PERFORMANCE CHARACTERISTICS

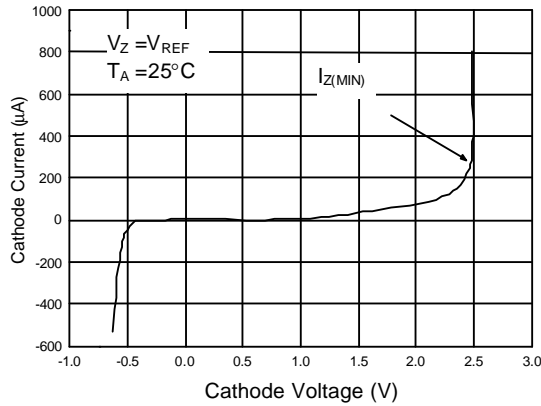

Fig. 4 Cathode Current vs. Cathode Voltage

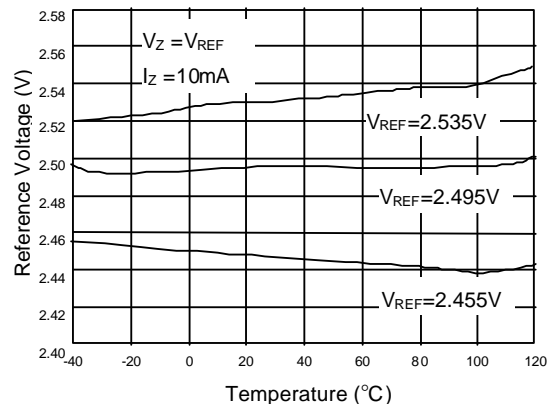

Fig. 5 Reference Voltage vs. Temperature

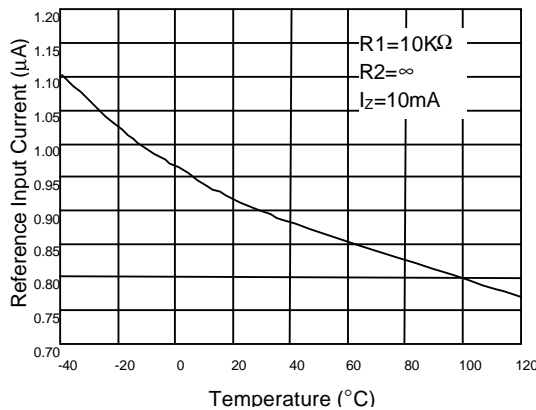

Fig. 6 Reference Input Current vs. Temperature

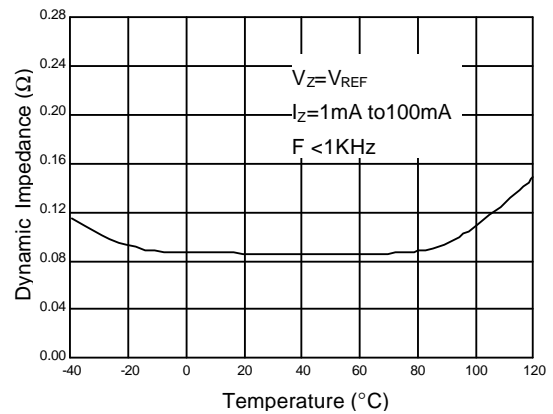

Fig. 7 Dynamic Impedance vs. Temperature

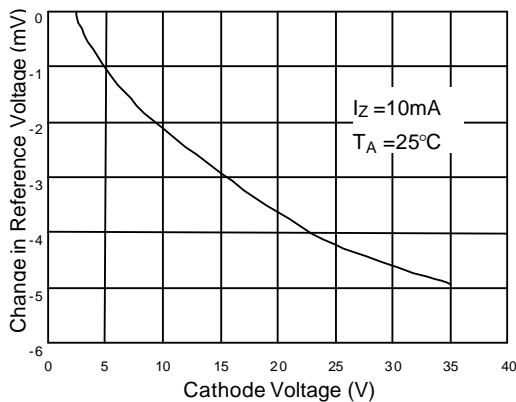

Fig. 8 Change in Reference Voltage vs. Cathode Voltage

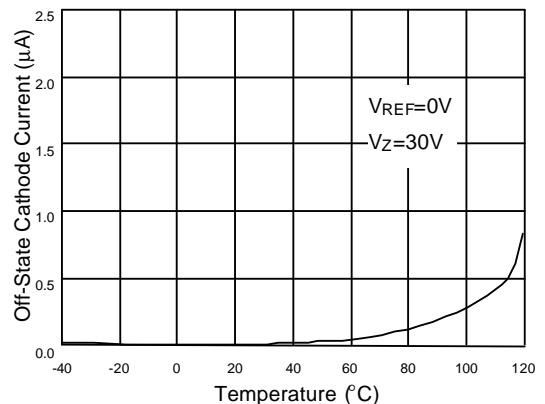

Fig. 9 Off-State Cathode Current vs. Temperature

TYPICAL PERFORMANCE CHARACTERISTICS (Continued)

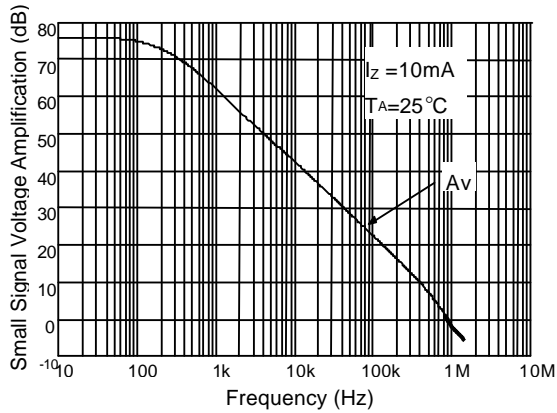

Fig. 10 Small Signal Voltage Amplification vs. Frequency

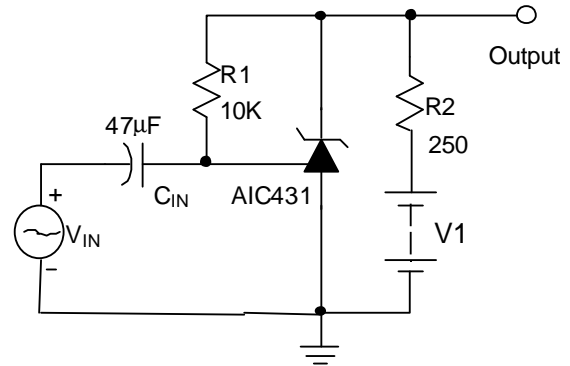

Fig. 11 Test Circuit For Frequency Response

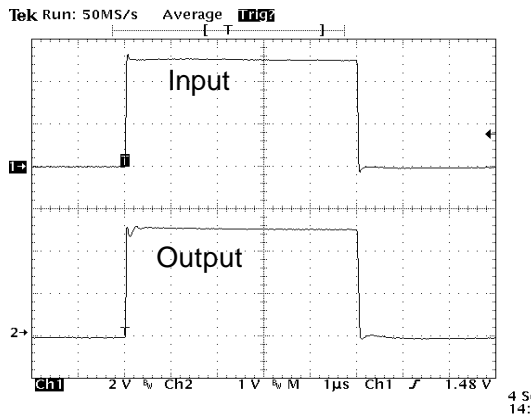

Fig. 12 Pulse Response

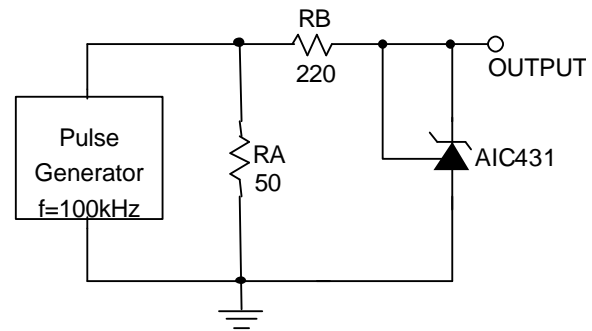

Fig. 13 Test Circuit For Pulse Response

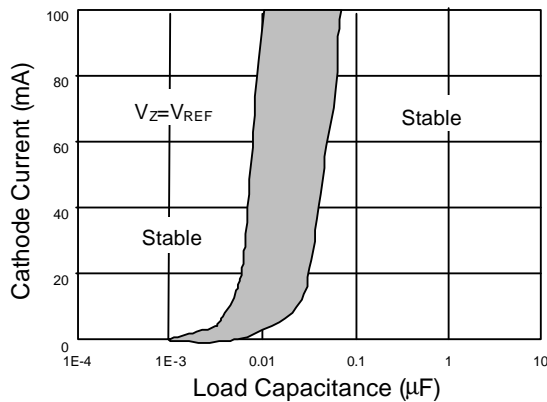

Fig. 14 Stability Boundary Conditions

The areas between the curves represent condition that may cause the device oscillate

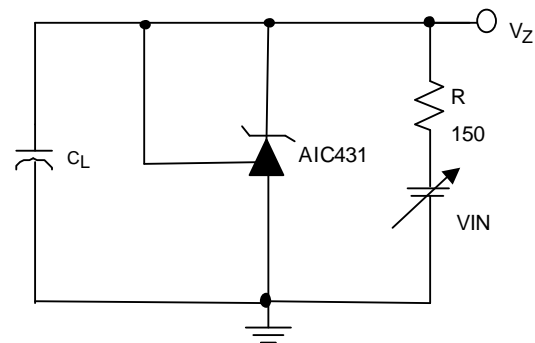

Fig. 15 Test Circuit for Stability Boundary

TYPICAL PERFORMANCE CHARACTERISTICS (Continued)

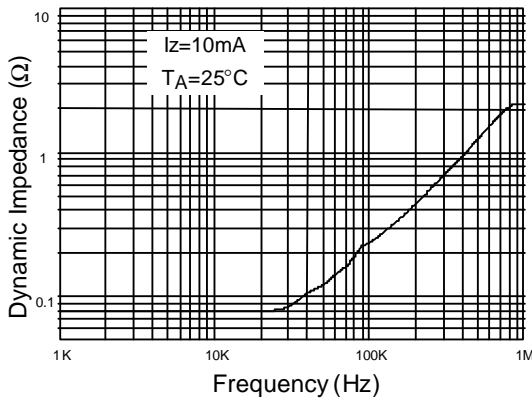

Fig. 16 Dynamic impedance vs. Frequency

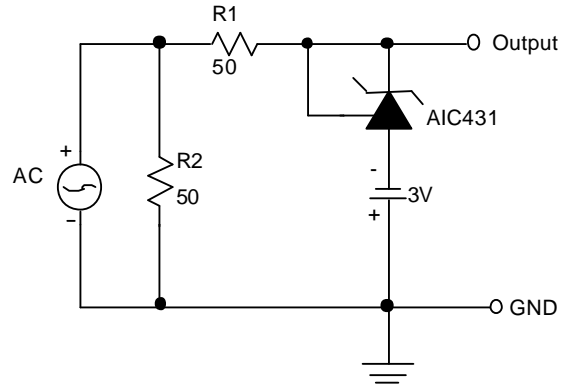
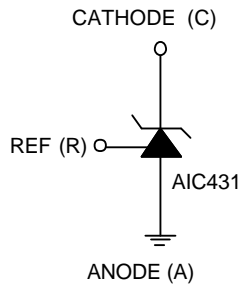
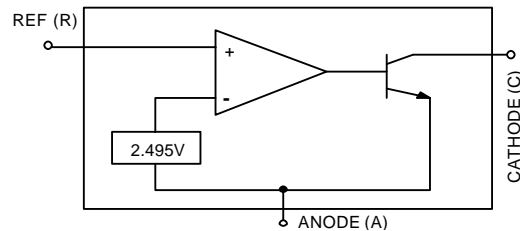

Fig. 17 Test Circuit for Dynamic Impedance

SYMBOL



BLOCK DIAGRAM



PIN DESCRIPTIONS

- CATHODE Pin - Sinks current with a range from 250μA to 200mA for normal applications.
- VREF Pin - Providing $V_{REF} = 2.495\text{V}$ (typ.) for adjustable output voltage.
- ANODE Pin - Anode pin sources current for normal application. The current value is the same as Cathode pin.

APPLICATION EXAMPLES

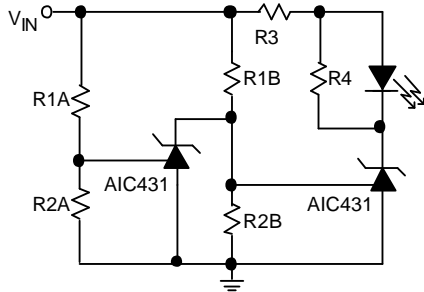

LED Turn on when $Low\ Limit < V_{IN} < High\ Limit$

$$Low\ Limit \cong V_{REF} (1 + R1B/R2B) \quad Delay = R \times C \times \ln \left(\frac{V_{IN}}{V_{IN} - V_{REF}} \right)$$

$$High\ Limit \cong V_{REF} (1 + R1A/R2A)$$

Fig. 18 Voltage Monitor

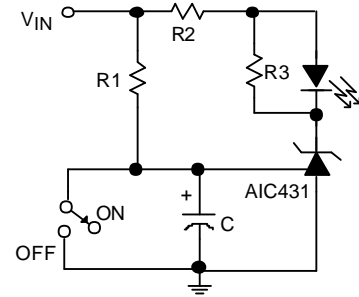
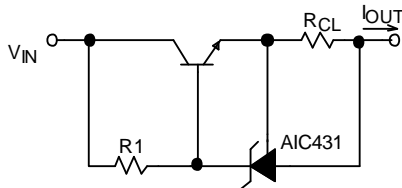
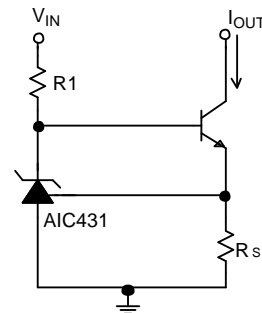

Fig. 19 Delay Timer



$$I_{OUT} = V_{REF} / R_{CL}$$

Fig. 20 Current Limiter or Current Source



$$I_{OUT} = V_{REF} / R_S$$

Fig. 21 Constant-Current Sink

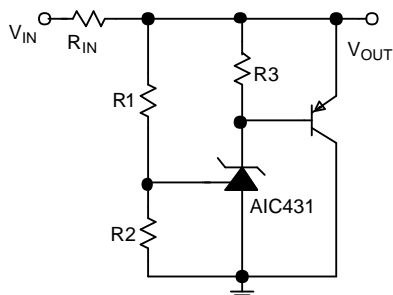

$$V_{OUT} \cong (1 + R1/R2) \times V_{REF}$$

Fig. 22. Higher-Current Shunt Regulator

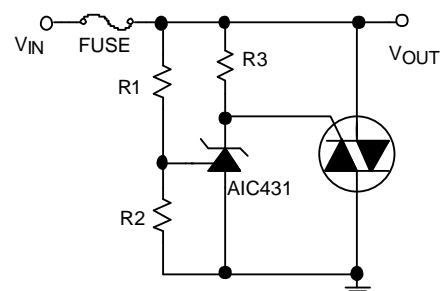

$$V_{LIMIT} \cong (1 + R1/R2) \times V_{REF}$$

Fig. 23 Crow Bar

APPLICATION EXAMPLES (Continued)

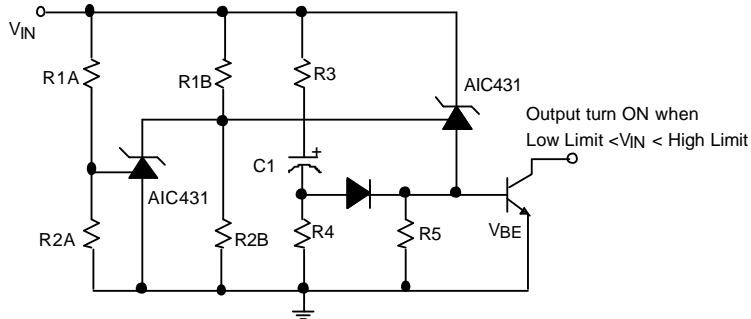

$$\text{Low Limit} \cong V_{REF} (1 + R1B / R2B) + V_{BE}$$

$$\text{High Limit} \cong V_{REF} (1 + R1A / R2A)$$

Fig 24. Over-Voltage/Under-Voltage Protection Circuit

PHYSICAL DIMENSIONS

- 8 LEAD PLASTIC SO (unit: mm)

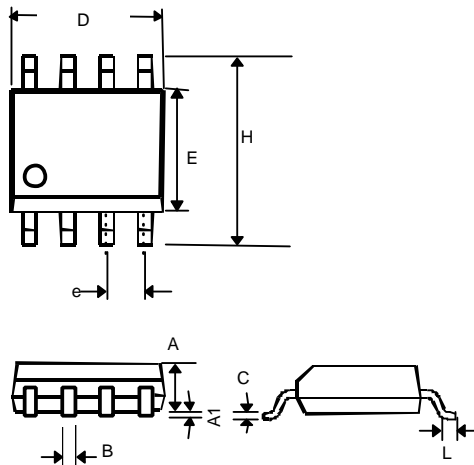

SYMBOL	MIN	MAX
A	1.35	1.75
A1	0.10	0.25
B	0.33	0.51
C	0.19	0.25
D	4.80	5.00
E	3.80	4.00
e	1.27(TYP)	
H	5.80	6.20
L	0.40	1.27

● SOT-23 (unit: mm)

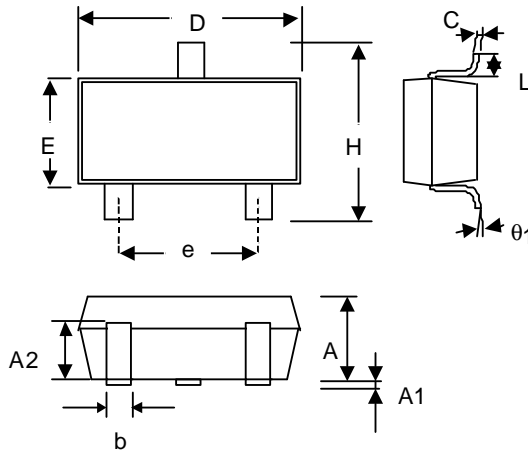

SYMBOL	MIN	MAX
A	1.00	1.30
A1	—	0.10
A2	0.70	0.90
b	0.35	0.50
C	0.10	0.25
D	2.70	3.10
E	1.40	1.80
e	1.90 (TYP)	
H	2.60	3.00
L	0.37	—
1	1°	9°

● SOT-23 MARKING

Part No.	Marking
AIC431CUN	AC1N
TL431CUN	AC2N
TL431ACUN	AC3N

Part No.	Marking
AIC431CUS	AC1S
TL431CUS	AC2S
TL431ACUS	AC3S

● SOT-89 (unit: mm)

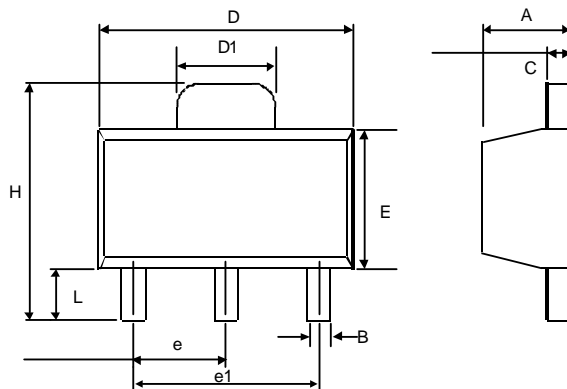

SYMBOL	MIN	MAX
A	1.40	1.60
B	0.36	0.48
C	0.35	0.44
D	4.40	4.60
D1	1.62	1.83
E	2.29	2.60
e	1.50 (TYP.)	
e1	3.00 (TYP.)	
H	3.94	4.25
L	0.89	1.20

● SOT-89 MARKING

Part No.	Marking
AIC431CX	AC01B
TL431CX	AC02B
TL431ACX	AC03B

● TO-92 (unit: mm)

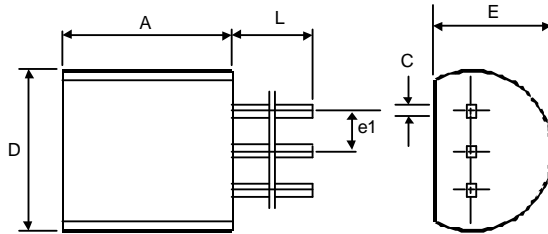

SYMBOL	MIN	MAX
A	4.32	5.33
C	0.38 (TYP.)	
D	4.40	5.20
E	3.17	4.20
e1	1.27 (TYP.)	
L	12.7	-