

671-680 + 671691

PRELIMINARY



Advanced
Micro
Devices

Am29F080

8 Megabit (1,048,576 x 8-Bit) CMOS 5.0 Volt-only,
Sector Erase Flash Memory

DISTINCTIVE CHARACTERISTICS

- **5.0 Volt \pm 10% for read and write operations**
 - Minimizes system level power requirements
- **Compatible with JEDEC-standards**
 - Pinout and software compatible with single-power-supply Flash
 - Superior inadvertent write protection
- **Package Options**
 - 40-pin TSOP
 - 44-pin PSOP
- **Minimum 100,000 write/erase cycles guaranteed**
- **High performance**
 - 85 ns maximum access time
- **Sector erase architecture**
 - Uniform sectors of 64 Kbytes each
 - Any combination of sectors can be erased. Also supports full chip erase
- **Group sector protection**
 - Hardware method that disables any combination of sector groups from write or erase operations (a sector group consists of 2 adjacent sectors of 64 Kbytes each)
- **Embedded Erase Algorithms**
 - Automatically pre-programs and erases the chip or any sector
- **Embedded Program Algorithms**
 - Automatically programs and verifies data at specified address
- **Data Polling and Toggle Bit feature for detection of program or erase cycle completion**
- **Ready/Busy output (RY/BY)**
 - Hardware method for detection of program or erase cycle completion
- **Erase Suspend/Resume**
 - Supports reading or programming data to a sector not being erased
- **Low power consumption**
 - 30 mA maximum active read current
 - 60 mA maximum program/erase current
- **Enhanced power management for standby mode**
 - $<1 \mu\text{A}$ typical standby current
 - Standard access time from standby mode
- **Hardware RESET pin**
 - Resets internal state machine to the read mode

GENERAL DESCRIPTION

The Am29F080 is an 8 Mbit, 5.0 Volt-only Flash memory organized as 1 Megabyte of 8 bits. The 1 Mbyte of data is divided into 16 sectors of 64 Kbytes for flexible erase capability. The 8 bits of data will appear on DQ0–DQ7. The Am29F080 is offered in a 40-pin TSOP, or 44-pin PSOP package. This device is designed to be programmed in-system with the standard system 5.0 Volt V_{CC} supply. 12.0 Volt V_{PP} is not required for program or erase operations. The device can also be reprogrammed in standard EPROM programmers.

The standard Am29F080 offers access times of 85 ns, 90 ns, 120 ns, and 150 ns allowing operation of high-speed microprocessors without wait states. To

eliminate bus contention the device has separate chip enable (\overline{CE}), write enable (\overline{WE}), and output enable (\overline{OE}) controls.

The Am29F080 is entirely command set compatible with the JEDEC single-power-supply Flash standard. Commands are written to the command register using standard microprocessor write timings. Register contents serve as input to an internal state-machine which controls the erase and programming circuitry. Write cycles also internally latch addresses and data needed for the programming and erase operations. Reading data out of the device is similar to reading from 12.0 Volt Flash or conventional EPROM devices.

GENERAL DESCRIPTION (continued)

The Am29F080 is programmed by executing the program command sequence. This will invoke the Embedded Program Algorithm which is an internal algorithm that automatically times the program pulse widths and verifies proper cell margin. Erase is accomplished by executing the erase command sequence. This will invoke the Embedded Erase Algorithm which is an internal algorithm that automatically preprograms the array if it is not already programmed before executing the erase operation. During erase, the device automatically times the erase pulse widths and verifies proper cell margin.

This device also features a sector erase architecture. This allows for sectors of memory to be erased and reprogrammed without affecting the data contents of other sectors. A sector is typically erased and verified within one second. The Am29F080 is erased when shipped from the factory.

The Am29F080 device also features hardware sector group protection. This feature will disable both program and erase operations in any combination of eight sector groups of memory. *A sector group consists of two adjacent sectors grouped in the following pattern: sectors 0-1, 2-3, 4-5, 6-7, 8-9, 10-11, 12-13, and 14-15.*

AMD has implemented an Erase Suspend feature that enables the user to put erase on hold for any period of time to read data from, or program data to, a sector that was not being erased. Thus, true background erase can be achieved.

The device features single 5.0 Volt power supply operation for both read and write functions. Internally generated and regulated voltages are provided for the program and erase operations. A low V_{CC} detector automatically inhibits write operations during power transitions. The end of program or erase is detected by the RY/ $\overline{\text{BY}}$ pin, $\overline{\text{Data}}$ Polling of DQ7, or by the Toggle Bit I (DQ6). Once the end of a program or erase cycle has been completed, the device automatically resets to the read mode.

The Am29F080 also has a hardware $\overline{\text{RESET}}$ pin. When this pin is driven low, execution of any Embedded Program Algorithm or Embedded Erase Algorithm will be terminated. The internal state machine will then be reset into the read mode. The $\overline{\text{RESET}}$ pin may be tied to

the system reset circuitry. Therefore, if a system reset occurs during the Embedded Program Algorithm or Embedded Erase Algorithm, the device will be automatically reset to the read mode and will leave erroneous data stored in the address locations being operated on. These locations will need re-writing after the Reset. Resetting the device will enable the system's microprocessor to read the boot-up firmware from the Flash memory.

AMD's Flash technology combines years of Flash memory manufacturing experience to produce the highest levels of quality, reliability and cost effectiveness. The Am29F080 memory electrically erases all bits within a sector simultaneously via Fowler-Nordheim tunneling. The bytes are programmed one byte at a time using the EPROM programming mechanism of hot electron injection.

Flexible Sector-Erase Architecture

- Sixteen 64 Kbyte sectors
- Eight sector groups each of which consists of 2 adjacent sectors in the following pattern: sectors 0-1, 2-3, 4-5, 6-7, 8-9, 10-11, 12-13, and 14-15
- Individual-sector or multiple-sector erase capability
- Sector group protection is user-definable

SA15	64 Kbyte	0EFFFFh	} Sector Group 7
SA14	64 Kbyte	0DFFFFh	
SA13	64 Kbyte	0CFFFFh	} Sector Group 0
SA12	64 Kbyte	0BFFFFh	
16 Sectors Total		0AFFFFh	
		09FFFFh	
		08FFFFh	
		07FFFFh	
		06FFFFh	
		05FFFFh	
		04FFFFh	
		03FFFFh	
SA3	64 Kbyte	02FFFFh	
SA2	64 Kbyte	01FFFFh	
SA1	64 Kbyte	00FFFFh	
SA0	64 Kbyte	000000h	

19643A-1

PRODUCT SELECTOR GUIDE

Family Part No.	Am29F080			
Ordering Part No:				
$V_{cc} = 5.0 \text{ Volt} \pm 5\%$	-85			
$V_{cc} = 5.0 \text{ Volt} \pm 10\%$		-90	-120	-150
Max Access Time (ns)	85	90	120	150
\overline{CE} (E) Access (ns)	85	90	120	150
\overline{OE} (G) Access (ns)	40	40	50	75

BLOCK DIAGRAM

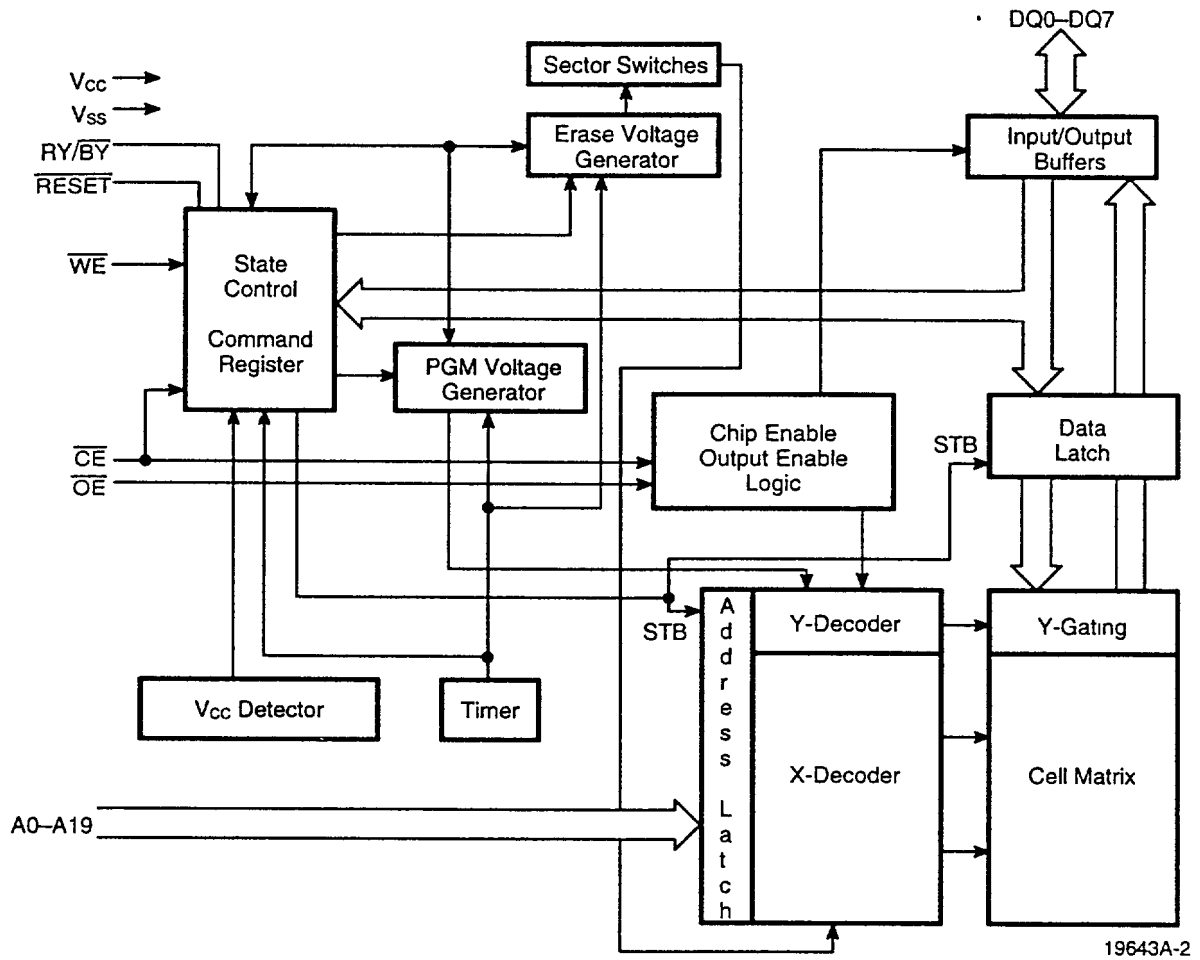

CONNECTION DIAGRAMS

8-Mbit Pinout

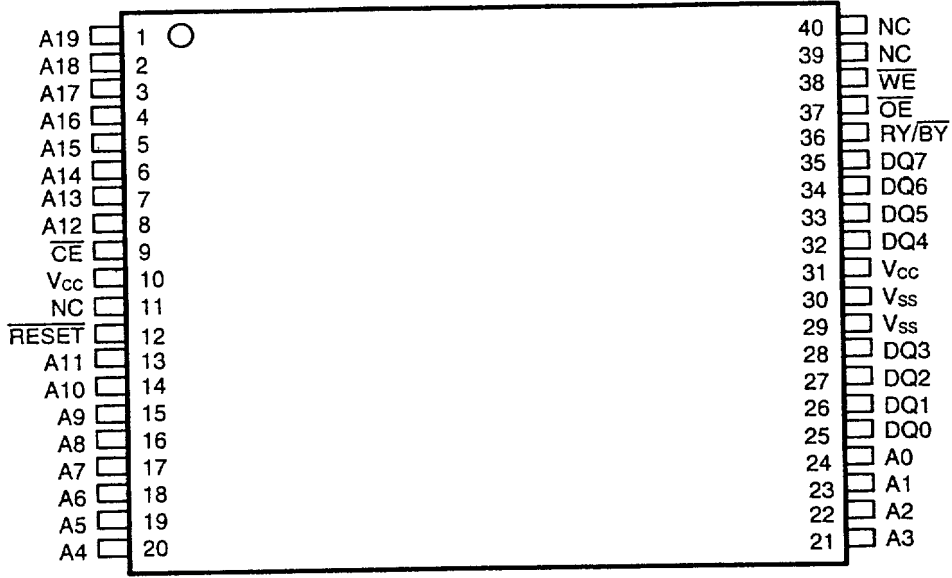

Standard TSOP

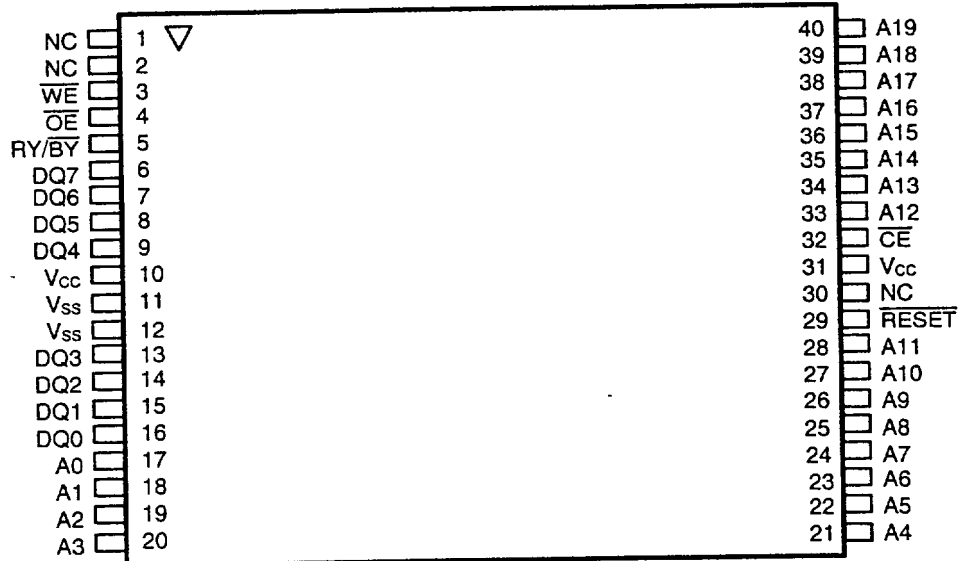

Reverse TSOP

19643A-3

CONNECTION DIAGRAMS

8-Mbit Pinout

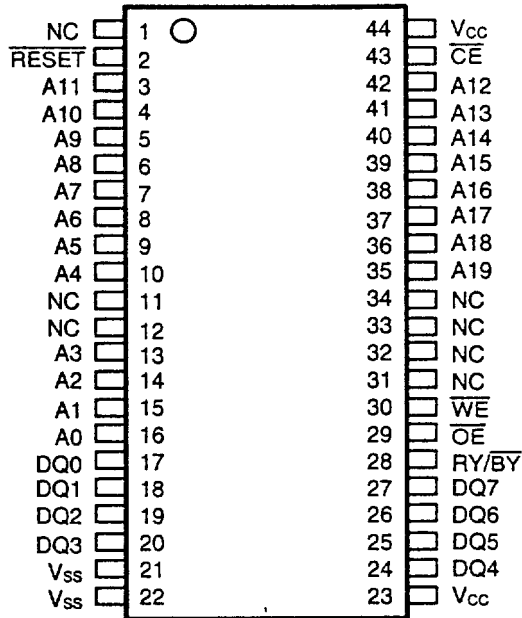

PSOP

19643A-3

PIN CONFIGURATION

- A0-A19 = 20 Addresses
- \overline{CE} = Chip Enable
- DQ0-DQ7 = 8 Data Inputs/Outputs
- NC = Pin Not Connected Internally
- \overline{OE} = Output Enable
- \overline{RESET} = Hardware Reset Pin, Active Low
- RY/ \overline{BY} = Ready/ \overline{BUSY} Output
- Vcc = +5.0 Volt Single-Power Supply
(±10% for -90, -120, -150) or
(±5% for -85)
- Vss = Device Ground
- \overline{WE} = Write Enable

LOGIC SYMBOL

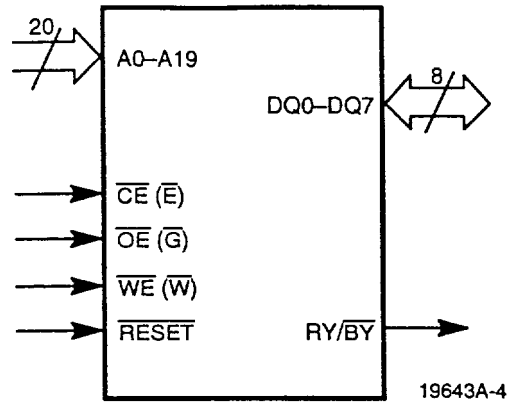

ORDERING INFORMATION

Standard Products

AMD standard products are available in several packages and operating ranges. The order number (Valid Combination) is formed by a combination of:

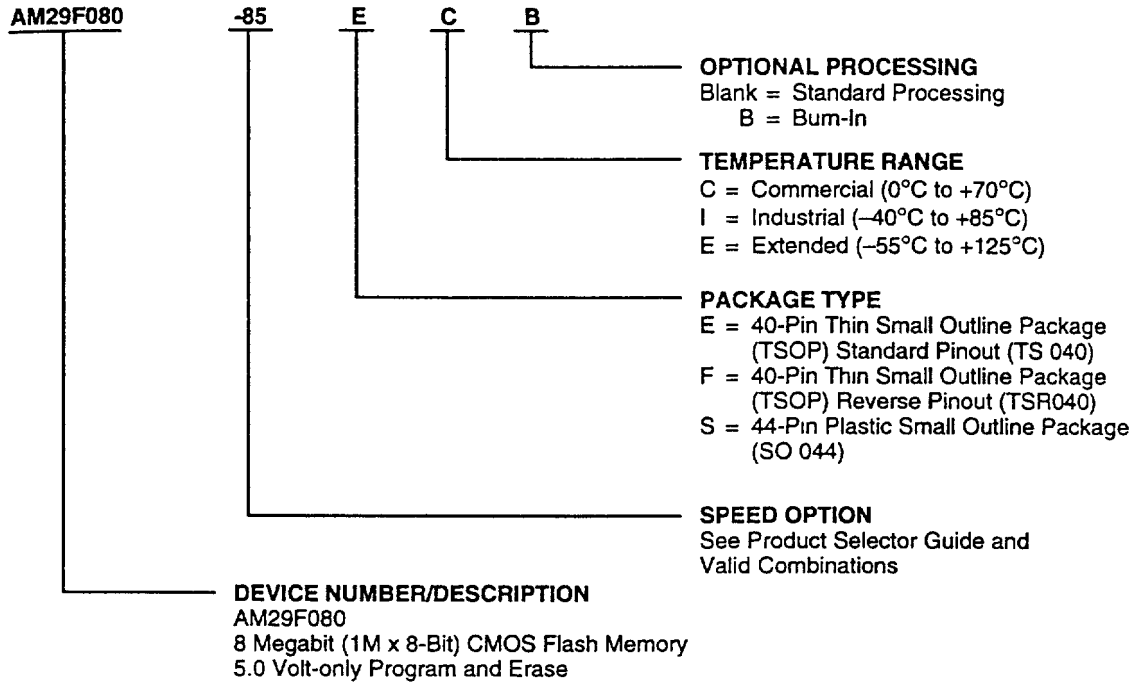

Valid Combinations	
AM29F080-85	EC, FC, SC
AM29F080-90	EC, FC, SC
AM29F080-120	EC, EI, FC, FI, EE,
AM29F080-150	EEB, EIB, FE, FEB, FIB, SC, SI, SE, SEB, SIB

Valid Combinations

Valid Combinations list configurations planned to be supported in volume for this device. Consult the local AMD sales office to confirm availability of specific valid combinations and to check on newly released combinations.

Table 1. Am29F080 User Bus Operations

Operation	\overline{CE}	\overline{OE}	\overline{WE}	A0	A1	A6	A9	DQ0–DQ7	\overline{RESET}
Autoselect, AMD Manuf. Code (1)	L	L	H	L	L	L	V _{ID}	Code	H
Autoselect Device Code (1)	L	L	H	H	L	L	V _{ID}	Code	H
Read	L	L	X	A0	A1	A6	A9	D _{OUT}	H
Standby	H	X	X	X	X	X	X	HIGH Z	H
Output Disable	L	H	H	X	X	X	X	HIGH Z	H
Write	L	H	L	A0	A1	A6	A9	D _{IN}	H
Verify Sector Group Protect (2)	L	L	H	L	H	L	V _{ID}	Code	H
Temporary Sector Group Unprotect	X	X	X	X	X	X	X	X	V _{ID}
Hardware Reset/Standby	X	X	X	X	X	X	X	HIGH Z	L

Legend:

L = logic 0, H = logic 1, X = Don't Care. See DC Characteristics for voltage levels.

Notes:

1. Manufacturer and device codes may also be accessed via a command register write sequence. Refer to Table 5.
2. Refer to the section on Sector Group Protection.

Read Mode

The Am29F080 has two control functions which must be satisfied in order to obtain data at the outputs. \overline{CE} is the power control and should be used for device selection. \overline{OE} is the output control and should be used to gate data to the output pins if the device is selected.

Address access time (t_{acc}) is equal to the delay from stable addresses to valid output data. The chip enable access time (t_{cE}) is the delay from stable addresses and stable \overline{CE} to valid data at the output pins. The output enable access time is the delay from the falling edge of \overline{OE} to valid data at the output pins (assuming the addresses have been stable for at least $t_{acc}-t_{oE}$ time).

Standby Mode

There are two ways to implement the standby mode on the Am29F080 device, one using both the \overline{CE} and \overline{RESET} pins; the other via the \overline{RESET} pin only.

When using both pins, a CMOS standby mode is achieved with \overline{CE} and \overline{RESET} inputs both held at $V_{CC} \pm 0.3$ V. Under this condition the current is typically

reduced to less than 1 μ A. A TTL standby mode is achieved with \overline{CE} and \overline{RESET} pins held at V_{IH} . Under this condition the current is typically reduced to 200 μ A. The device can be read with standard access time (t_{cE}) from either of these standby modes.

When using the \overline{RESET} pin only, a CMOS standby mode is achieved with \overline{RESET} input held at $V_{SS} \pm 0.3$ V (\overline{CE} = don't care). Under this condition the current is typically reduced to less than 1 μ A. A TTL standby mode is achieved with \overline{RESET} pin held at V_{IL} (\overline{CE} = don't care). Under this condition the current is typically reduced to less than 200 μ A. Once the \overline{RESET} pin is taken high, the device requires 500 ns of wake up time before outputs are valid for read access.

In the standby mode the outputs are in the high impedance state, independent of the \overline{OE} input.

Output Disable

With the \overline{OE} input at a logic high level (V_{IH}), output from the device is disabled. This will cause the output pins to be in a high impedance state.

Autoselect

The autoselect mode allows the reading of a binary code from the device and will identify its manufacturer and type. This mode is intended for use by programming equipment for the purpose of automatically matching the device to be programmed with its corresponding programming algorithm. This mode is functional over the entire temperature range of the device.

To activate this mode, the programming equipment must force V_{ID} (11.5 V to 12.5 V) on address pin A9. Two identifier bytes may then be sequenced from the device outputs by toggling address A0 from V_{IL} to V_{IH} . All addresses are don't cares except A0, A1, and A6 (see Table 2).

The manufacturer and device codes may also be read via the command register, for instances when the Am29F080 is erased or programmed in a system

without access to high voltage on the A9 pin. The command sequence is illustrated in Table 5 (see Autoselect Command Sequence).

Byte 0 ($A0 = V_{IL}$) represents the manufacturer's code ($AMD=01H$) and byte 1 ($A0 = V_{IH}$) the device identifier code for Am29F080 = D5H. These two bytes are given in the table below. All identifiers for manufacturer and device will exhibit odd parity with DQ7 defined as the parity bit. In order to read the proper device codes when executing the Autoselect, A1 must be V_{IL} (see Table 2).

The autoselect mode also facilitates the determination of sector group protection in the system. By performing a read operation at the address location XX02H with the higher order address bits A17, A18, and A19 set to the desired sector group address, the device will return 01H for a protected sector group and 00H for a non-protected sector group.

Table 2. Am29F080 Sector Protection Verify Autoselect Codes

Type	A17 to A19			A6	A1	A0	Code (HEX)	DQ7	DQ6	DQ5	DQ4	DQ3	DQ2	DQ1	DQ0
Manufacturer Code—AMD	X	X	X	V_{IL}	V_{IL}	V_{IL}	01H	0	0	0	0	0	0	0	1
Am29F080 Device	X	X	X	V_{IL}	V_{IL}	V_{IH}	D5H	1	1	0	1	0	1	0	1
Sector Group Protection	Sector Group Addr.			V_{IL}	V_{IH}	V_{IL}	01H*	0	0	0	0	0	0	0	1

*Outputs 01H at protected sector addresses

Table 3. Sector Address Table

	A19	A18	A17	A16	Address Range
SA0	0	0	0	0	00000h–00FFFFh
SA1	0	0	0	1	01000h–01FFFFh
SA2	0	0	1	0	02000h–02FFFFh
SA3	0	0	1	1	03000h–03FFFFh
SA4	0	1	0	0	04000h–04FFFFh
SA5	0	1	0	1	05000h–05FFFFh
SA6	0	1	1	0	06000h–06FFFFh
SA7	0	1	1	1	07000h–07FFFFh
SA8	1	0	0	0	08000h–08FFFFh
SA9	1	0	0	1	09000h–09FFFFh
SA10	1	0	1	0	0A000h–0AFFFFh
SA11	1	0	1	1	0B000h–0BFFFFh
SA12	1	1	0	0	0C000h–0CFFFFh
SA13	1	1	0	1	0D000h–0DFFFFh
SA14	1	1	1	0	0E000h–0EFFFFh
SA15	1	1	1	1	0F000h–0FFFFh

Table 4. Sector Group Addresses

	A19	A18	A17	Sectors
SGA0	0	0	0	SA0–SA1
SGA1	0	0	1	SA2–SA3
SGA2	0	1	0	SA4–SA5
SGA3	0	1	1	SA6–SA7
SGA4	1	0	0	SA8–SA9
SGA5	1	0	1	SA10–SA11
SGA6	1	1	0	SA12–SA13
SGA7	1	1	1	SA14–SA15

Write

Device erasure and programming are accomplished via the command register. The contents of the register serve as inputs to the internal state machine. The state machine outputs dictate the function of the device.

The command register itself does not occupy any addressable memory location. The register is a latch used to store the commands, along with the address and data information needed to execute the command. The command register is written to by bringing \overline{WE} to V_{IL} , while \overline{CE} is at V_{IL} and \overline{OE} is at V_{IH} . Addresses are latched on the falling edge of \overline{WE} or \overline{CE} , whichever happens later; while data is latched on the rising edge of \overline{WE} or \overline{CE} , whichever happens first. Standard microprocessor write timings are used.

Refer to AC Write Characteristics and the Erase/Programming Waveforms for specific timing parameters.

Sector Group Protection

The Am29F080 features hardware sector group protection. This feature will disable both program and erase operations in any combination of eight sector groups of memory. Each sector group consists of two adjacent sectors grouped in the following pattern: sectors 0–1, 2–3, 4–5, 6–7, 8–9, 10–11, 12–13, 14–15 (see Table 4). The sector group protect feature is enabled using programming equipment at the user's site. The device is shipped with all sector groups unprotected. Alternatively, AMD may program and protect sector groups in the factory prior to shipping the device (AMD's ExpressFlash Service).

It is possible to determine if a sector group is protected in the system by writing an Autoselect command. Performing a read operation at the address location XX02H, where the higher order address bits A17, A18, and A19 is the desired sector group address, will produce a logical "1" at DQ0 for a protected sector group. See Table 2 for Autoselect codes.

Temporary Sector Group Unprotect

This feature allows temporary unprotection of previously protected sector groups of the Am29F080 device in order to change data in-system. The Sector Group Unprotect mode is activated by setting the \overline{RESET} pin to high voltage (12V). During this mode, formerly protected sector groups can be programmed or erased by selecting the sector group addresses. Once the 12V is taken away from the \overline{RESET} pin, all the previously protected sector groups will be protected again. Refer to Figures 15 and 16.

Command Definitions

Device operations are selected by writing specific address and data sequences into the command register. **Writing incorrect address and data values or writing them in the improper sequence will reset the device to the read mode.** Table 5 defines the valid register command sequences. Note that the Erase Suspend (BOH) and Erase Resume (30H) commands are valid only while the Sector Erase operation is in progress. Moreover, both Reset/Read commands are functionally equivalent, resetting the device to the read mode.

Table 5. Am29F080 Command Definitions (Notes 1–5)

Command Sequence Read/Reset	Bus Write Cycles Req'd	First Bus Write Cycle		Second Bus Write Cycle		Third Bus Write Cycle		Fourth Bus Read/Write Cycle		Fifth Bus Write Cycle		Sixth Bus Write Cycle	
		Addr	Data	Addr	Data	Addr	Data	Addr	Data	Addr	Data	Addr	Data
Reset/Read	1	XXXXH	F0H										
Reset/Read	3	5555H	AAH	2AAAH	55H	5555H	F0H	RA	RD				
Autoselect	3	5555H	AAH	2AAAH	55H	5555H	90H	00H/01H	01H/D5H				
Byte Program	4	5555H	AAH	2AAAH	55H	5555H	A0H	PA	PD				
Chip Erase	6	5555H	AAH	2AAAH	55H	5555H	80H	5555H	AAH	2AAAH	55H	5555H	10H
Sector Erase	6	5555H	AAH	2AAAH	55H	5555H	80H	5555H	AAH	2AAAH	55H	SA	30H
Erase Suspend	1	XXXXH	B0H										
Erase Resume	1	XXXXH	30H										

Notes:

1. Bus operations are defined in Table 1.
2. RA = Address of the memory location to be read.
PA = Address of the memory location to be programmed. Addresses are latched on the falling edge of the \overline{WE} pulse.
SA = Address of the sector to be erased. The combination of A19, A18, A17, and A16 will uniquely select any sector.
3. RD = Data read from location RA during read operation.
PD = Data to be programmed at location PA. Data is latched on the rising edge of \overline{WE} .
4. Read and Byte program functions to non-erasing sectors are allowed in the Erase Suspend mode.
5. Address bits A15, A14, A13, A12 and A11 = X, X = don't care.

Read/Reset Command

The read or reset operation is initiated by writing the read/reset command sequence into the command register. Microprocessor read cycles retrieve array data from the memory. The device remains enabled for reads until the command register contents are altered.

The device will automatically power-up in the read/reset state. In this case, a command sequence is not required to read data. Standard microprocessor read cycles will retrieve array data. This default value ensures that no spurious alteration of the memory content occurs during the power transition. Refer to the AC Read Characteristics and Waveforms for the specific timing parameters.

Autoselect Command

Flash memories are intended for use in applications where the local CPU can alter memory contents. As such, manufacture and device codes must be accessible while the device resides in the target system. PROM programmers typically access the signature codes by raising A9 to a high voltage. However, multiplexing high voltage onto the address lines is not generally a desirable system design practice.

The device contains an autoselect command operation to supplement traditional PROM programming methodology. The operation is initiated by writing the autoselect command sequence into the command register. Following the command write, a read cycle from address XX00H retrieves the manufacturer code of 01H. A read cycle from address XX01H returns the device code D5H (see Table 2).

All manufacturer and device codes will exhibit odd parity with DQ7 defined as the parity bit.

Furthermore, the write protect status of sectors can be read in this mode. Scanning the sector group addresses (A17, A18, and A19) while (A6, A1, A0) = (0, 1, 0) will produce a logical "1" at device output DQ0 for a protected sector group.

To terminate the operation, it is necessary to write the read/reset command sequence into the register.

Byte Programming

The device is programmed on a byte-by-byte basis. Programming is a four bus cycle operation. There are two "unlock" write cycles. These are followed by the program set-up command and data write cycles. Addresses are latched on the falling edge of \overline{CE} or \overline{WE} , whichever happens later and the data is latched on the rising edge of \overline{CE} or \overline{WE} , whichever happens first. The rising edge of \overline{CE} or \overline{WE} (whichever happens first) begins programming using the Embedded Program Algorithm. Upon executing the algorithm, the system is *not* required to provide further controls or timings. The device will automatically provide adequate internally generated program pulses and verify the programmed cell margin.

The automatic programming operation is completed when the data on DQ7 (also used as Data Polling) is equivalent to the data written to this bit at which time the device returns to the read mode and addresses are no longer latched (see Table 6, Write Operation Status). Therefore, the device requires that a valid address to the device be supplied by the system at this particular instance of time for Data Polling operations. Data Polling must be performed at the memory location which is being programmed.

Any commands written to the chip during the Embedded Program Algorithm will be ignored. If a hardware reset occurs during the programming operation, the data at that particular location will be corrupted.

Programming is allowed in any sequence and across sector boundaries. Beware that a data "0" cannot be

programmed back to a "1". Attempting to do so may cause the device to exceed programming time limits (DQ5 = 1) device or result in an apparent success, according to the data polling algorithm, but a read from reset/read mode will show that the data is still "0". Only erase operations can convert "0"s to "1"s.

Figure 1 illustrates the Embedded Programming Algorithm using typical command strings and bus operations.

Chip Erase

Chip erase is a six bus cycle operation. There are two "unlock" write cycles. These are followed by writing the "set-up" command. Two more "unlock" write cycles are then followed by the chip erase command.

Chip erase does *not* require the user to program the device prior to erase. Upon executing the Embedded Erase Algorithm command sequence the device will automatically program and verify the entire memory for an all zero data pattern prior to electrical erase. The erase is performed sequentially one sector at a time (See table "Erase and Programming Performance" for erase times). The system is not required to provide any controls or timings during these operations.

The automatic erase begins on the rising edge of the last \overline{WE} pulse in the command sequence and terminates when the data on DQ7 is "1" (see Write Operation Status section) at which time the device returns to read mode.

Figure 2 illustrates the Embedded Erase Algorithm using typical command strings and bus operations.

Sector Erase

Sector erase is a six bus cycle operation. There are two "unlock" write cycles. These are followed by writing the "set-up" command. Two more "unlock" write cycles are then followed by the sector erase command. The sector address (any address location within the desired sector) is latched on the falling edge of \overline{WE} , while the command (30H) is latched on the rising edge of \overline{WE} . After a time-out of 50 μ s from the rising edge of the last sector erase command, the sector erase operation will begin.

Multiple sectors may be erased sequentially by writing the six bus cycle operations as described above. This sequence is followed with writes of the Sector Erase command to addresses in other sectors desired to be sequentially erased. The time between writes must be less than 50 μ s otherwise that command will not be accepted and erasure will start. It is recommended that processor interrupts be disabled during this time to guarantee this condition. The interrupts can be re-enabled after the last Sector Erase command is written. A time-out of 50 μ s from the rising edge of the last \overline{WE} will initiate the execution of the Sector Erase command(s). If another falling edge of the \overline{WE} occurs within the 50 μ s time-out window the timer is reset. (Monitor DQ3 to determine if the sector erase timer window is still open, see section DQ3, Sector Erase Timer.) Any command other than Sector Erase or Erase Suspend during this period will reset the device to the read mode, ignoring

the previous command string. In that case, restart the erase on those sectors and allow them to complete.

(Refer to the Write Operation Status section for DQ3, Sector Erase Timer, operation.) Loading the sector erase buffer may be done in any sequence and with any number of sectors (0 to 15).

Sector erase does *not* require the user to program the device prior to erase. The device automatically programs all memory locations in the sector(s) to be erased prior to electrical erase. When erasing a sector or sectors the remaining unselected sectors are not affected. The system is *not* required to provide any controls or timings during these operations.

The automatic sector erase begins after the 50 μ s time out from the rising edge of the \overline{WE} pulse for the last sector erase command pulse and terminates when the data on DQ7, \overline{Data} Polling, is "1" (see Write Operation Status section) at which time the device returns to the read mode. \overline{Data} Polling must be performed at an address within any of the sectors being erased.

Figure 2 illustrates the Embedded Erase Algorithm using typical command strings and bus operations.

Erase Suspend

The Erase Suspend command allows the user to interrupt a Sector Erase operation and then perform data reads or programs to a sector not being erased. This command is applicable **ONLY** during the Sector Erase operation which includes the time-out period for sector erase. The Erase Suspend command will be ignored if written during the Chip Erase operation or Embedded Program Algorithm. Writing the Erase Suspend command during the Sector Erase time-out results in immediate termination of the time-out period and suspension of the erase operation.

Any other command written during the Erase Suspend mode will be ignored except the Erase Resume command. Writing the Erase Resume command resumes the erase operation. The addresses are "don't-cares" when writing the Erase Suspend or Erase Resume command.

When the Erase Suspend command is written during the Sector Erase operation, the device will take a maximum of 20 μ s to suspend the erase operation. When the device has entered the erase-suspended mode, the RY/ \overline{BY} output pin and the DQ7 bit will be at logic '1', and DQ6 will stop toggling. The user must use the address of the erasing sector for reading DQ6 and DQ7 to determine if the erase operation has been suspended. Further writes of the Erase Suspend command are ignored.

When the erase operation has been suspended, the device defaults to the erase-suspend-read mode. Reading data in this mode is the same as reading from the standard read mode except that the data must be read from sectors that have not been erase-suspended. Successively reading from the erase-suspended sector while the device is in the erase-suspend-read mode will cause DQ2 to toggle. (See the section on DQ2).

After entering the erase-suspend-read mode, the user can program the device by writing the appropriate command sequence for Byte Program. This program mode is known as the erase-suspend-program mode. Again, programming in this mode is the same as programming in the regular Byte Program mode except that the data must be programmed to sectors that are not erase-suspended. Successively reading from the erase-suspended sector while the device is in the erase-suspend-program mode will cause DQ2 to toggle. The end of the erase-suspended program operation is detected by the RY/ \overline{BY} output pin, \overline{Data} Polling of DQ7, or by the Toggle Bit 1 (DQ6) which is the same as the regular Byte Program operation. Note that DQ7 must be read from the byte program address while DQ6 can be read from any address.

To resume the operation of Sector Erase, the Resume command (30H) should be written. Any further writes of the Resume command at this point will be ignored. Another Erase Suspend command can be written after the chip has resumed erasing.

Write Operation Status

Table 6. Write Operation Status

	Status		DQ7	DQ6	DQ5	DQ3	DQ2
	In Progress	Byte Program in Embedded Program Algorithm		$\overline{\text{DQ7}}$	Toggle	0	0
Embedded Erase Algorithm		0	Toggle	0	1	Toggle	
Erase Suspended Mode		Erase Suspend Read (Erase Suspended Sector)	1	1	0	0	Toggle (Note 1)
		Erase Suspend Read (Non-Erase Suspended Sector)	Data	Data	Data	Data	Data
	Erase Suspend Program (Non-Erase Suspended Sector)	$\overline{\text{DQ7}}$	Toggle (Note 2)	0	0	1 (Note 3)	
Exceeded Time Limits	Byte Program in Embedded Program Algorithm		$\overline{\text{DQ7}}$	Toggle	1	0	1
	Program/Erase in Embedded Erase Algorithm		0	Toggle	1	1	N/A
	Erase Suspended Mode	Erase Suspend Program (Non-Erase Suspended Sector)	$\overline{\text{DQ7}}$	Toggle	1	1	N/A

Notes:

1. Performing successive read operations from the erase-suspended sector will cause DQ2 to toggle.
2. Performing successive read operations from any address will cause DQ6 to toggle.
3. Reading the byte address being programmed while in the erase-suspend program mode will indicate logic '1' at the DQ2 bit. However, successive reads from the erase-suspended sector will cause DQ2 to toggle.

DQ7
Data Polling

The Am29F080 device features $\overline{\text{Data}}$ Polling as a method to indicate to the host that the embedded algorithms are in progress or completed. During the Embedded Program Algorithm, an attempt to read the device will produce the complement of the data last written to DQ7. Upon completion of the Embedded Program Algorithm, an attempt to read the device will produce the true data last written to DQ7. During the Embedded Erase Algorithm, an attempt to read the device will produce a "0" at the DQ7 output. Upon completion of the Embedded Erase Algorithm an attempt to read the device will produce a "1" at the DQ7 output. The flowchart for $\overline{\text{Data}}$ Polling (DQ7) is shown in Figure 3.

$\overline{\text{Data}}$ Polling will also flag the entry into Erase Suspend. DQ7 will switch "0" to "1" at the start of the Erase Suspend mode. Please note that the address of an erasing sector must be applied in order to observe DQ7 in the Erase Suspend Mode.

During Program in Erase Suspend, $\overline{\text{Data}}$ Polling will perform the same as in regular program execution outside of the suspend mode.

For chip erase, the $\overline{\text{Data}}$ Polling is valid after the rising edge of the sixth $\overline{\text{WE}}$ pulse in the six write pulse sequence. For sector erase, the $\overline{\text{Data}}$ Polling is valid after the last rising edge of the sector erase $\overline{\text{WE}}$ pulse. $\overline{\text{Data}}$ Polling must be performed at sector addresses within any of the sectors being erased and **not** a sector that is within a protected sector group. Otherwise, the status may not be valid.

Just prior to the completion of Embedded Algorithm operations DQ7 may change asynchronously while the output enable ($\overline{\text{OE}}$) is asserted low. This means that the device is driving status information on DQ7 at one instant of time and then that byte's valid data at the next instant of time. Depending on when the system samples the DQ7 output, it may read the status or valid data. Even if the device has completed the Embedded Algorithm operations and DQ7 has a valid data, the data outputs on DQ0–DQ6 may be still invalid. The valid data on DQ0–DQ7 can be read on the successive read attempts.

The $\overline{\text{Data}}$ Polling feature is only active during the Embedded Programming Algorithm, Embedded Erase Algorithm, Erase Suspend, erase-suspend-program mode, or sector erase time-out (see Table 6).

See Figure 11 for the $\overline{\text{Data}}$ Polling timing specifications and diagrams.

DQ6
Toggle Bit I

The Am29F080 also features the "Toggle Bit I" as a method to indicate to the host system that the embedded algorithms are in progress or completed.

During an Embedded Program or Erase Algorithm cycle, successive attempts to read ($\overline{\text{OE}}$ toggling) data from the device *at any address* will result in DQ6 toggling between one and zero. Once the Embedded Program or Erase Algorithm cycle is completed, DQ6 will stop toggling and valid data will be read on *the next* successive attempt. During programming, the Toggle Bit I is valid after the rising edge of the fourth $\overline{\text{WE}}$ pulse in

the four write pulse sequence. For chip erase, the Toggle Bit I is valid after the rising edge of the sixth \overline{WE} pulse in the six write pulse sequence. For Sector Erase, the Toggle Bit I is valid after the last rising edge of the sector erase \overline{WE} pulse. The Toggle Bit I is active during the sector erase time-out.

Either \overline{CE} or \overline{OE} toggling will cause DQ6 to toggle. In addition, an Erase Suspend/Resume command will cause DQ6 to toggle. See Figure 12 for the Toggle Bit I timing specifications and diagrams.

DQ5

Exceeded Timing Limits

DQ5 will indicate if the program or erase time has exceeded the specified limits (internal pulse count). Under these conditions DQ5 will produce a "1". This is a failure condition which indicates that the program or erase cycle was not successfully completed. Data Polling is the only operating function of the device under this condition. The \overline{CE} circuit will partially power down the device under these conditions (to approximately 2 mA). The \overline{OE} and \overline{WE} pins will control the output disable functions as described in Table 1.

The DQ5 failure condition will also appear if a user tries to program a 1 to a location that is previously programmed to 0. In this case the device locks out and never completes the Embedded Program Algorithm. Hence, the system never reads a valid data on DQ7 bit and DQ6 never stops toggling. Once the device has exceeded timing limits, the DQ5 bit will indicate a "1." Please note that this is not a device failure condition since the device was incorrectly used. If this occurs, reset the device.

DQ3

Sector Erase Timer

After the completion of the initial sector erase command sequence the sector erase time-out will begin. DQ3 will remain low until the time-out is complete. Data Polling and Toggle Bit I are valid after the initial sector erase command sequence.

If Data Polling or the Toggle Bit I indicates the device has been written with a valid erase command, DQ3 may be used to determine if the sector erase timer window is still open. If DQ3 is high ("1") the internally controlled erase cycle has begun; attempts to write subsequent commands (other than Erase Suspend) to the device will be ignored until the erase operation is completed as indicated by Data Polling or Toggle Bit I. If DQ3 is low

("0"), the device will accept additional sector erase commands. To insure the command has been accepted, the system software should check the status of DQ3 prior to and following each subsequent sector erase command. If DQ3 were high on the second status check, the command may not have been accepted.

Refer to Table 6: Write Operation Status.

DQ2

Toggle Bit II

This toggle bit, along with DQ6, can be used to determine whether the device is in the Embedded Erase Algorithm or in Erase Suspend.

Successive reads from the erasing sector will cause DQ2 to toggle during the Embedded Erase Algorithm. If the device is in the erase-suspended-read mode, successive reads from the erase-suspend sector will cause DQ2 to toggle. When the device is in the erase-suspended-program mode, successive reads from the byte address of the non-erase suspended sector will indicate a logic '1' at the DQ2 bit.

DQ6 is different from DQ2 in that DQ6 toggles only when the standard Program or Erase, or Erase Suspend Program operation is in progress. The behavior of these two status bits, along with that of DQ7, is summarized as follows:

Mode	DQ7	DQ6	DQ2
Program	$\overline{DQ7}$	toggles	1
Erase	0	toggles	toggles
Erase Suspend Read (1) (Erase-Suspended Sector)	1	1	toggles
Erase Suspend Program	$\overline{DQ7}$ (2)	toggles	toggles

Notes:

1. These status flags apply when outputs are read from a sector that has been erase-suspended.
2. These status flags apply when outputs are read from the byte address of the non-erase suspended sector.

For example, DQ2 and DQ6 can be used together to determine the erase-suspend-read mode (DQ2 toggles while DQ6 does not). See also Table 6 and Figure 17. Furthermore, DQ2 can also be used to determine which sector is being erased. When the device is in the erase mode, DQ2 toggles if this bit is read from the erasing sector.

$\overline{RY/BY}$ **Ready/Busy**

The Am29F080 provides a $\overline{RY/BY}$ open-drain output pin as a way to indicate to the host system that the Embedded Algorithms are either in progress or has been completed. If the output is low, the device is busy with either a program or erase operation. If the output is high, the device is ready to accept any read/write or erase operation. When the $\overline{RY/BY}$ pin is low, the device will not accept any additional program or erase commands with the exception of the Erase Suspend command. If the Am29F080 is placed in an Erase Suspend mode, the $\overline{RY/BY}$ output will be high.

During programming, the $\overline{RY/BY}$ pin is driven low after the rising edge of the fourth \overline{WE} pulse. During an erase operation, the $\overline{RY/BY}$ pin is driven low after the rising edge of the sixth \overline{WE} pulse. The $\overline{RY/BY}$ pin will indicate a busy condition during the \overline{RESET} pulse. Refer to Figure 13 for a detailed timing diagram. The $\overline{RY/BY}$ pin is pulled high in standby mode.

Since this is an open-drain output, several $\overline{RY/BY}$ pins can be tied together in parallel with a pull-up resistor to V_{CC} .

\overline{RESET}

Hardware Reset

The Am29F080 device may be reset by driving the \overline{RESET} pin to V_{IL} . The \overline{RESET} pin must be kept low (V_{IL}) for at least 500 ns. Any operation in progress will be terminated and the internal state machine will be reset to the read mode 20 μ s after the \overline{RESET} pin is driven low. If a hardware reset occurs during a program or erase operation, the data at that particular location will be indeterminate.

When the \overline{RESET} pin is low and the internal reset is complete, the device goes to standby mode and cannot be accessed. Also, note that all the data output pins are tri-stated for the duration of the \overline{RESET} pulse. Once the \overline{RESET} pin is taken high, the device requires 500 ns of wake up time until outputs are valid for read access.

The \overline{RESET} pin may be tied to the system reset input. Therefore, if a system reset occurs during the Embedded Program or Erase Algorithm, the device will be

automatically reset to read mode and this will enable the system's microprocessor to read the boot-up firmware from the Flash memory.

Data Protection

The Am29F080 is designed to offer protection against accidental erasure or programming caused by spurious system level signals that may exist during power transitions. During power up the device automatically resets the internal state machine in the Read mode. Also, with its control register architecture, alteration of the memory contents only occurs after successful completion of specific multi-bus cycle command sequences.

The device also incorporates several features to prevent inadvertent write cycles resulting from V_{CC} power-up and power-down transitions or system noise.

Low V_{CC} Write Inhibit

To avoid initiation of a write cycle during V_{CC} power-up and power-down, the Am29F080 locks out write cycles for $V_{CC} < V_{LKO}$ (see DC Characteristics section for voltages). When $V_{CC} < V_{LKO}$, the command register is disabled, all internal program/erase circuits are disabled, and the device resets to the read mode. The Am29F080 ignores all writes until $V_{CC} > V_{LKO}$. The user must ensure that the control pins are in the correct logic state when $V_{CC} > V_{LKO}$ to prevent unintentional writes.

Write Pulse "Glitch" Protection

Noise pulses of less than 5 ns (typical) on \overline{OE} , \overline{CE} , or \overline{WE} will not initiate a write cycle.

Logical Inhibit

Writing is inhibited by holding any one of $\overline{OE} = V_{IL}$, $\overline{CE} = V_{IH}$, or $\overline{WE} = V_{IH}$. To initiate a write cycle \overline{CE} and \overline{WE} must be a logical zero while \overline{OE} is a logical one.

Power-Up Write Inhibit

Power-up of the device with $\overline{WE} = \overline{CE} = V_{IL}$ and $\overline{OE} = V_{IH}$ will not accept commands on the rising edge of \overline{WE} . The internal state machine is automatically reset to the read mode on power-up.

EMBEDDED ALGORITHMS

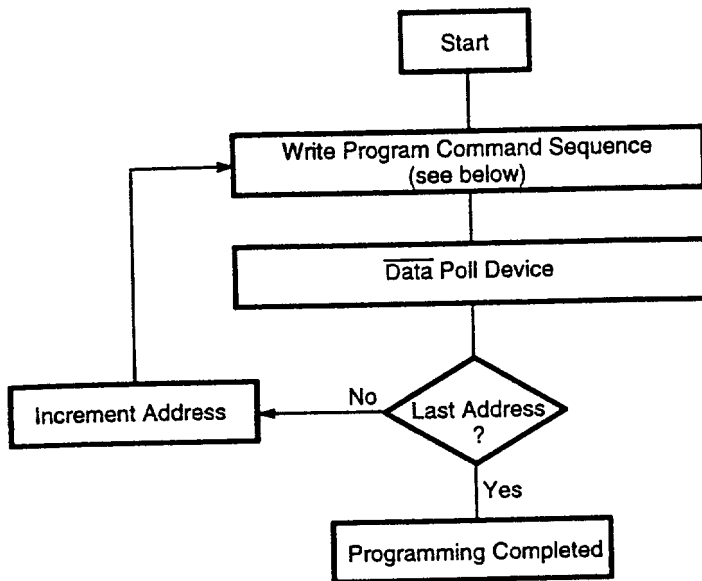

Program Command Sequence (Address/Command):

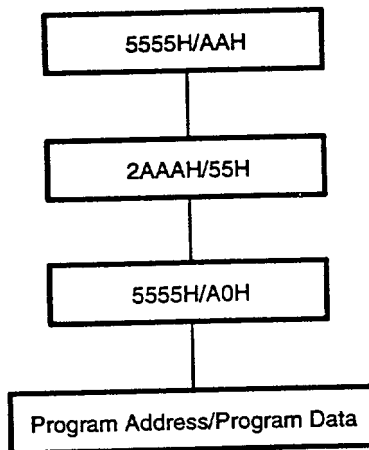

19643A-5

Figure 1. Embedded Programming Algorithm

EMBEDDED ALGORITHMS

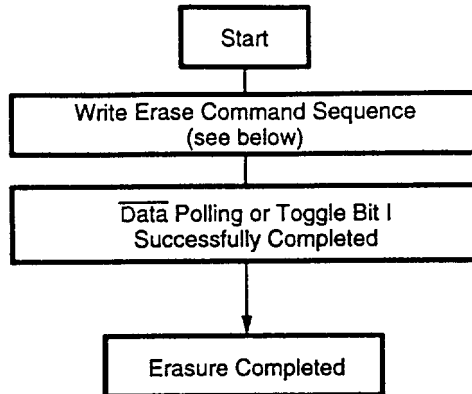

Chip Erase Command Sequence
(Address/Command):

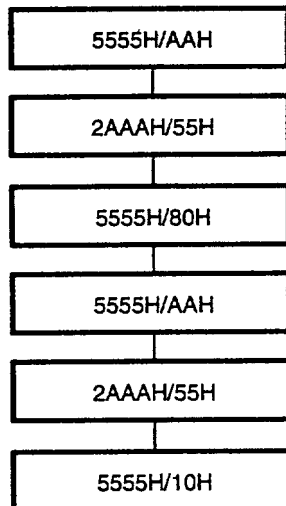

Individual Sector/Multiple Sector
Erase Command Sequence
(Address/Command):

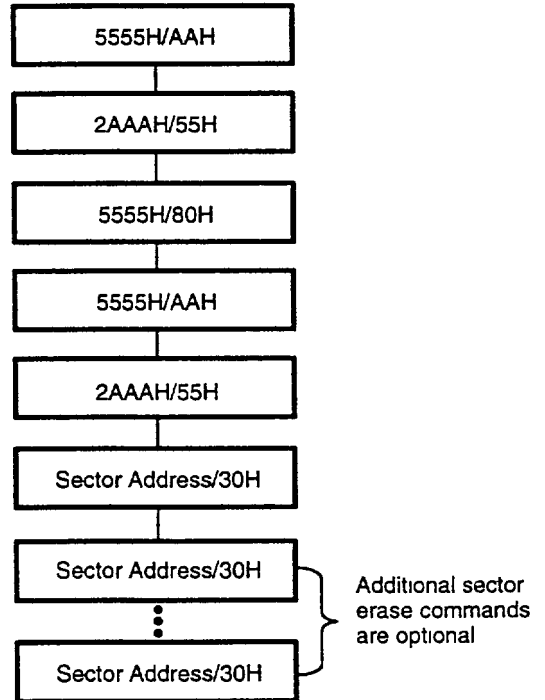

19643A-6

Note:

1. To insure the command has been accepted, the system software should check the status of DQ3 prior to and following each subsequent sector erase command. If DQ3 were high on the second status check, the command may not have been accepted.

Figure 2. Embedded Erase Algorithm

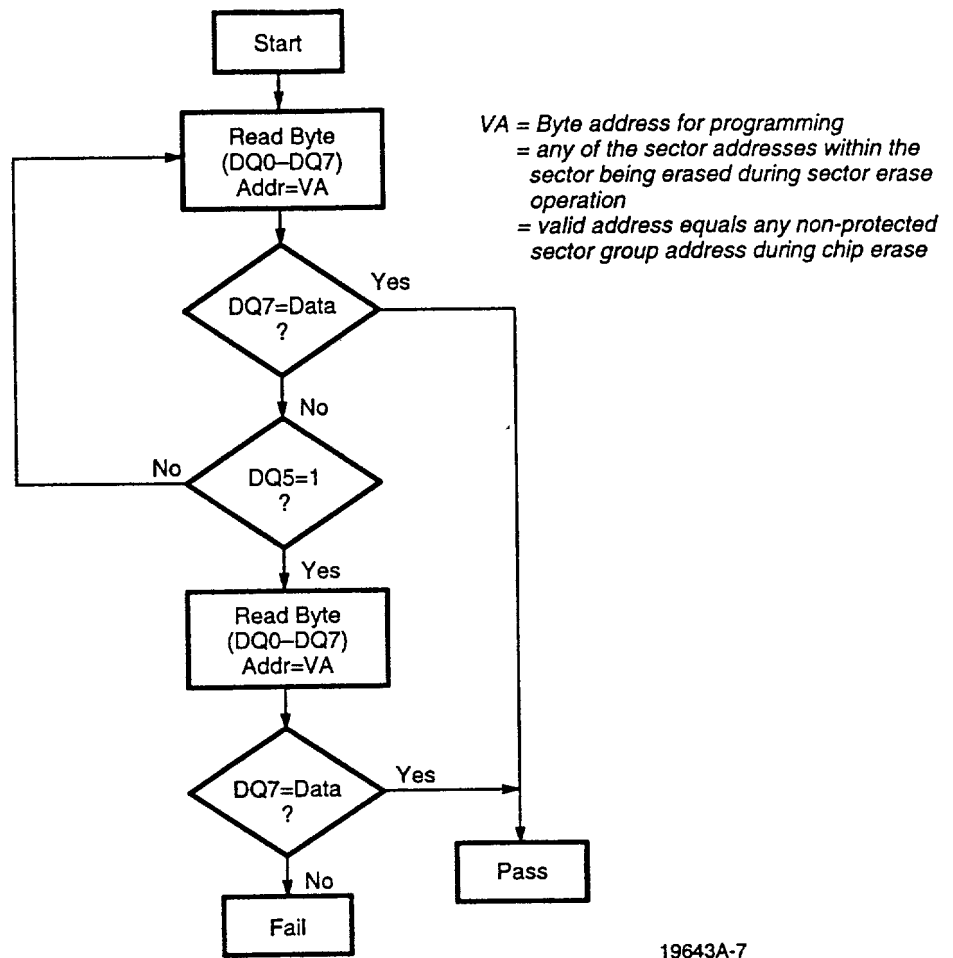

19643A-7

Note:

1. DQ7 is rechecked even if DQ5 = "1" because DQ7 may change simultaneously with DQ5.

Figure 3. Data Polling Algorithm

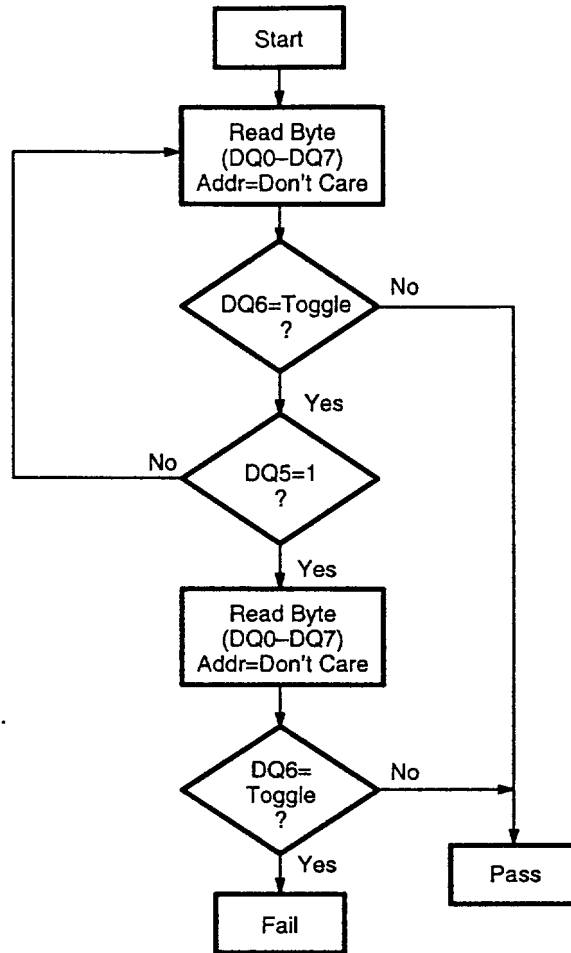

19643A-8

Note:

1. DQ6 is rechecked even if DQ5 = "1" because DQ6 may stop toggling at the same time as DQ5 changing to "1".

Figure 4. Toggle Bit I Algorithm

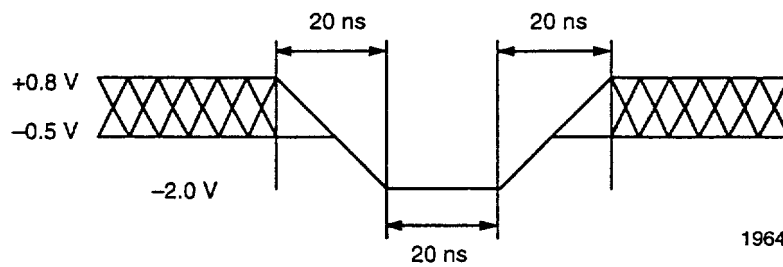

19643A-9

Figure 5. Maximum Negative Overshoot Waveform

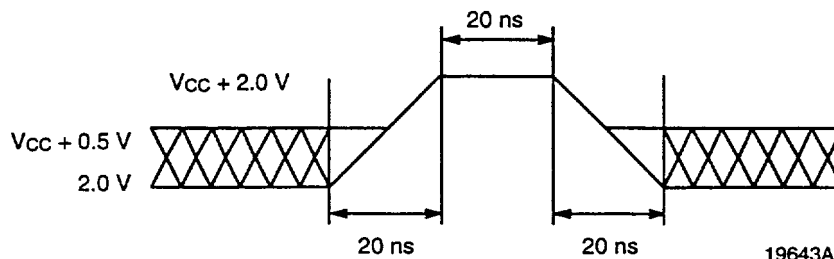

19643A-10

Figure 6. Maximum Positive Overshoot Waveform

ABSOLUTE MAXIMUM RATINGS

Storage Temperature	
Plastic Packages	-65°C to +125°C
Ambient Temperature	
with Power Applied	-55°C to +125°C
Voltage with Respect to Ground	
All pins except A9 (Note 1)	-2.0 V to +7.0 V
V _{cc} (Note 1)	-2.0 V to +7.0 V
A9, \overline{OE} , \overline{RESET} (Note 2)	-2.0 V to +13.5 V
Output Short Circuit Current (Note 3)	200 mA

Notes:

1. Minimum DC voltage on input or I/O pins is -0.5 V. During voltage transitions, inputs may overshoot V_{SS} to -2.0 V for periods of up to 20 ns. Maximum DC voltage on input and I/O pins is V_{cc} + 0.5 V. During voltage transitions, input and I/O pins may overshoot to V_{cc} + 2.0 V for periods up to 20 ns.
2. Minimum DC input voltage on A9, \overline{OE} , \overline{RESET} pins is -0.5 V. During voltage transitions, A9, \overline{OE} , \overline{RESET} pins may overshoot V_{SS} to -2.0 V for periods of up to 20 ns. Maximum DC input voltage on A9 is +12.5 V which may overshoot to 14.0 V for periods up to 20 ns.
3. No more than one output shorted to ground at a time. Duration of the short circuit should not be greater than one second.

Stresses above those listed under "Absolute Maximum Ratings" may cause permanent damage to the device. This is a stress rating only; functional operation of the device at these or any other conditions above those indicated in the operational sections of this specification is not implied. Exposure of the device to absolute maximum rating conditions for extended periods may affect device reliability.

OPERATING RANGES

Commercial (C) Devices	
Ambient Temperature (T _A)	0°C to +70°C
Industrial (I) Devices	
Ambient Temperature (T _A)	-40°C to +85°C
Extended (E) Devices	
Ambient Temperature (T _A)	-55°C to +125°C
V_{cc} Supply Voltages	
V _{cc} for Am29F080-85	+4.75 V to +5.25 V
V _{cc} for Am29F080-90, 120, 150	+4.50 V to +5.50 V

Operating ranges define those limits between which the functionality of the device is guaranteed.

DC CHARACTERISTICS
TTL/NMOS Compatible

Parameter Symbol	Parameter Description	Test Conditions	Min	Max	Unit
I _{LI}	Input Load Current	V _{IN} = V _{SS} to V _{CC} , V _{CC} = V _{CC} Max		±1.0	μA
I _{LIT}	A9 Input Load Current	V _{CC} = V _{CC} Max, A9 = 12.0 Volt		50	μA
I _{LO}	Output Leakage Current	V _{OUT} = V _{SS} to V _{CC} , V _{CC} = V _{CC} Max		±1.0	μA
I _{CC1}	V _{CC} Active Read Current (Note 1)	$\overline{OE} = V_{IL}, \overline{OE} = V_{IH}$		30	mA
I _{CC2}	V _{CC} Active Program/Erase Current (Notes 2, 3)	$\overline{CE} = V_{IL}, \overline{OE} = V_{IH}$		60	mA
I _{CC3}	V _{CC} Standby Current	V _{CC} = V _{CC} Max, $\overline{CE} = V_{IH}, \overline{RESET} = V_{IH}$		1.0	mA
I _{CC4}	V _{CC} Standby Current (Reset)	V _{CC} = V _{CC} Max, $\overline{RESET} = V_{IL}$		1.0	mA
V _{IL}	Input Low Voltage		-0.5	0.8	V
V _{IH}	Input High Voltage		2.0	V _{CC} + 0.5	V
V _{ID}	Voltage for Autoselect and Temporary Sector Unprotect	V _{CC} = 5.0 Volt	11.5	12.5	V
V _{OL}	Output Low Voltage	I _{OL} = 12 mA, V _{CC} = V _{CC} Min		0.45	V
V _{OH}	Output High Voltage	I _{OH} = -2.5 mA, V _{CC} = V _{CC} Min	2.4		V
V _{LKO}	Low V _{CC} Lock-Out Voltage		3.2	4.2	V

Notes:

1. The I_{CC} current listed includes both the DC operating current and the frequency dependent component (at 6 MHz). The frequency component typically is less than 1 mA/MHz, with \overline{OE} at V_{IH}.
2. I_{CC} active while Embedded Program or Erase Algorithm is in progress.
3. Not 100% tested.

DC CHARACTERISTICS (continued)

CMOS Compatible

Parameter Symbol	Parameter Description	Test Conditions	Min	Max	Unit
I_{LI}	Input Load Current	$V_{IN} = V_{SS}$ to V_{CC} , $V_{CC} = V_{CC}$ Max		± 1.0	μA
I_{LIT}	A9 Input Load Current	$V_{CC} = V_{CC}$ Max, A9 = 12.0 Volt		50	μA
I_{LO}	Output Leakage Current	$V_{OUT} = V_{SS}$ to V_{CC} , $V_{CC} = V_{CC}$ Max		± 1.0	μA
I_{CC1}	V_{CC} Active Read Current (Note 1)	$\overline{CE} = V_{IL}$, $\overline{OE} = V_{IH}$		30	mA
I_{CC2}	V_{CC} Active Current Program/Erase (Notes 2, 3)	$\overline{CE} = V_{IL}$, $\overline{OE} = V_{IH}$		60	mA
I_{CC3}	V_{CC} Standby Current	$V_{CC} = V_{CC}$ Max, $\overline{CE} = V_{CC} \pm 0.3$ V, $\overline{RESET} = V_{CC} \pm 0.3$ V		5	μA
I_{CC4}	V_{CC} Standby Current (Reset)	$V_{CC} = V_{CC}$ Max, $\overline{RESET} = V_{SS} \pm 0.3$ V		5	μA
V_{IL}	Input Low Voltage		-0.5	0.8	V
V_{IH}	Input High Voltage		0.7x V_{CC}	V_{CC} +0.3	V
V_{ID}	Voltage for Autoselect and Temporary Sector Unprotect	$V_{CC} = 5.0$ Volt	11.5	12.5	V
V_{OL}	Output Low Voltage	$I_{OL} = 12$ mA, $V_{CC} = V_{CC}$ Min		0.45	V
V_{OH1}	Output High Voltage	$I_{OH} = -2.5$ mA, $V_{CC} = V_{CC}$ Min	0.85 V_{CC}		V
V_{OH2}		$I_{OH} = -100$ μA , $V_{CC} = V_{CC}$ Min	V_{CC} -0.4		V
V_{LKO}	Low V_{CC} Lock-out Voltage		3.2	4.2	V

Notes:

1. The I_{CC} current listed includes both the DC operating current and the frequency dependent component (at 6 MHz). The frequency component typically is less than 1 mA/MHz, with \overline{OE} at V_{IH} .
2. I_{CC} active while Embedded Program or Erase Algorithm is in progress.
3. Not 100% tested.

AC CHARACTERISTICS
Read-only Operations Characteristics

Parameter Symbols		Description	Test Setup		-85 (Note 1)	-90 (Note 2)	-120 (Note 2)	-150 (Note 2)	Unit
JEDEC	Standard								
t _{AVAV}	t _{RC}	Read Cycle Time (Note 3)		Min	85	90	120	150	ns
t _{AVQV}	t _{ACC}	Address to Output Delay	$\overline{CE} = V_{IL}$ $\overline{OE} = V_{IL}$	Max	85	90	120	150	ns
t _{ELQV}	t _{CE}	Chip Enable to Output Delay	$\overline{OE} = V_{IL}$	Max	85	90	120	150	ns
t _{GLQV}	t _{OE}	Output Enable to Output Delay		Max	40	40	50	55	ns
t _{EHQZ}	t _{DF}	Chip Enable to Output High Z (Notes 3 and 4)		Max	20	20	30	35	ns
t _{GHQZ}	t _{DF}	Output Enable to Output High Z (Notes 3 and 4)		Max	20	20	30	35	ns
t _{AXQX}	t _{OH}	Output Hold Time From Addresses, \overline{CE} or \overline{OE} , Whichever Occurs First		Min	0	0	0	0	ns
	t _{Ready}	\overline{RESET} Pin Low to Read Mode (Note 4)		Max	20	20	20	20	μs

Notes:

1. Test Conditions:
 Output Load: 1 TTL gate and 30 pF
 Input rise and fall times: 5 ns
 Input pulse levels: 0.0 V to 3.0 V
 Timing measurement reference level
 Input: 1.5 V
 Output: 1.5 V
2. Test Conditions:
 Output Load: 1 TTL gate and 100 pF
 Input rise and fall times: 20 ns
 Input pulse levels: 0.45 V to 2.4 V
 Timing measurement reference level
 Input: 0.8 and 2.0 V
 Output: 0.8 and 2.0 V
3. Output driver disable time.
4. Not 100% tested.

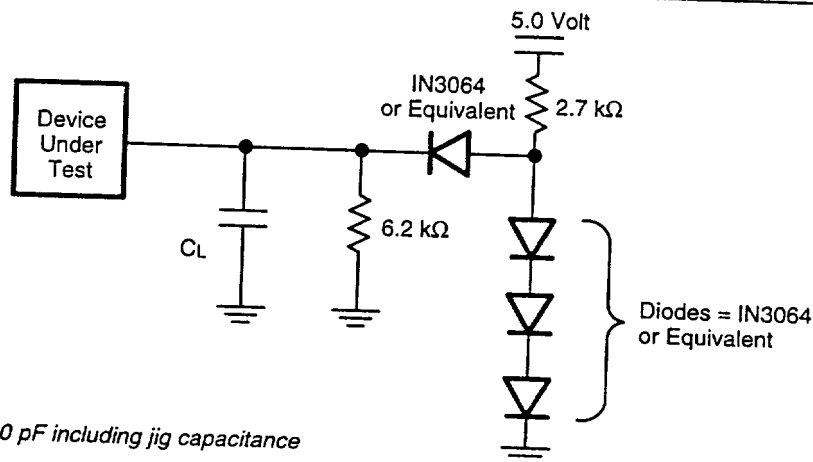

Note:

For all others: $C_L = 100$ pF including jig capacitance
 For -85: $C_L = 30$ pF

Figure 7. Test Conditions

19643A-11

AC CHARACTERISTICS

Write/Erase/Program Operations

Parameter Symbols		Description						Unit
JEDEC	Standard							
tAVAV	tWC	Write Cycle Time (Note 2)	Min	85	90	120	150	ns
tAVWL	tAS	Address Setup Time	Min	0	0	0	0	ns
twLAX	tAH	Address Hold Time	Min	40	45	50	50	ns
tdVWH	tDS	Data Setup Time	Min	40	45	50	50	ns
twHDX	tDH	Data Hold Time	Min	0	0	0	0	ns
	toEH	Output Enable Hold Time						
		Read (Note 2)	Min	0	0	0	0	ns
		Toggle Bit I and Data Polling (Note 2)	Min	10	10	10	10	ns
tGHWL	tGHWL	Read Recover Time Before Write (OE high to WE low)	Min	0	0	0	0	ns
teLWL	tCS	CE Setup Time	Min	0	0	0	0	ns
twHEH	tCH	CE Hold Time	Min	0	0	0	0	ns
twLWH	tWP	Write Pulse Width	Min	40	45	50	50	ns
twHWL	tWPH	Write Pulse Width High	Min	20	20	20	20	ns
tWHWH1	tWHWH1	Byte Programming Operation	Typ	8	8	8	8	μs
tWHWH2	tWHWH2	Sector Erase Operation (Note 1)	Typ	1	1	1	1	sec
			Max	15	15	15	15	sec
	tvCS	Vcc Set Up Time (Note 2)	Min	50	50	50	50	μs
	tVIDR	Rise Time to VID (Notes 2, 3)	Min	500	500	500	500	ns
	toESP	OE Setup Time to WE Active (Notes 2, 3)	Min	4	4	4	4	μs
	trP	RESET Pulse Width	Min	500	500	500	500	ns
	tBUSY	Program/Erase Valid to RY/BY Delay	Min	40	40	50	60	ns

Notes:

1. This does not include the preprogramming time.
2. Not 100% tested.
3. These timings are for Temporary Sector Group Unprotect operation.

KEY TO SWITCHING WAVEFORMS

WAVEFORM	INPUTS	OUTPUTS
	Must Be Steady	Will Be Steady
	May Change from H to L	Will Be Changing from H to L
	May Change from L to H	Will Be Changing from L to H
	Don't Care, Any Change Permitted	Changing, State Unknown
	Does Not Apply	Center Line is High-Impedance "Off" State

KS000010

SWITCHING WAVEFORMS

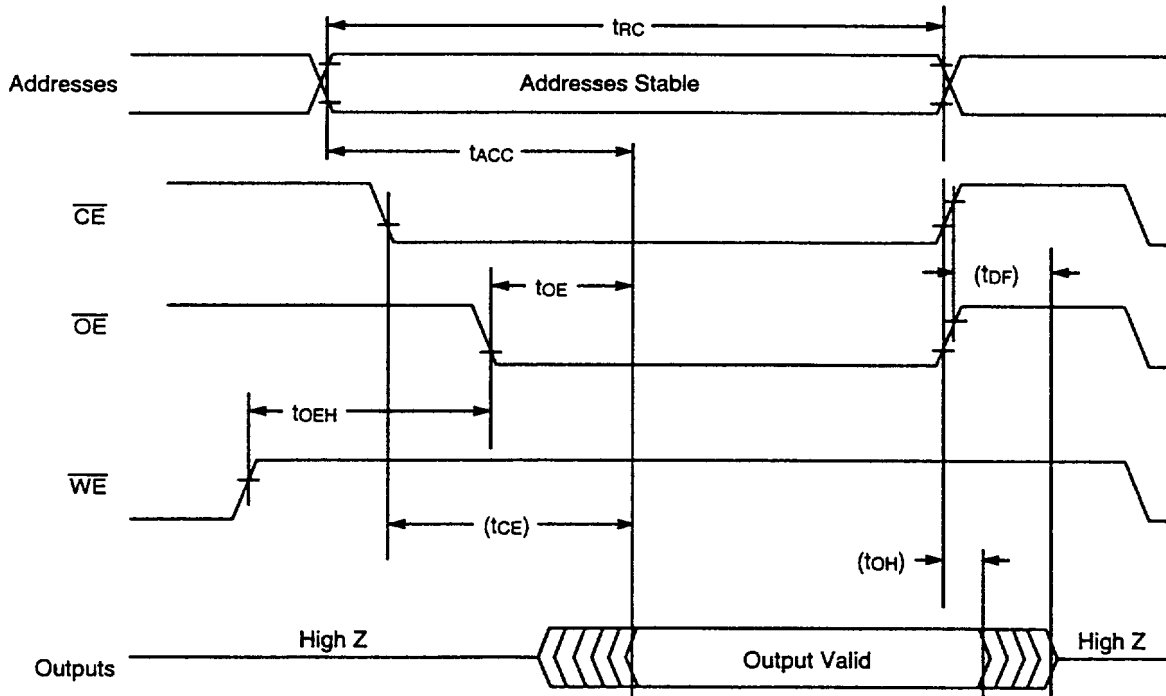
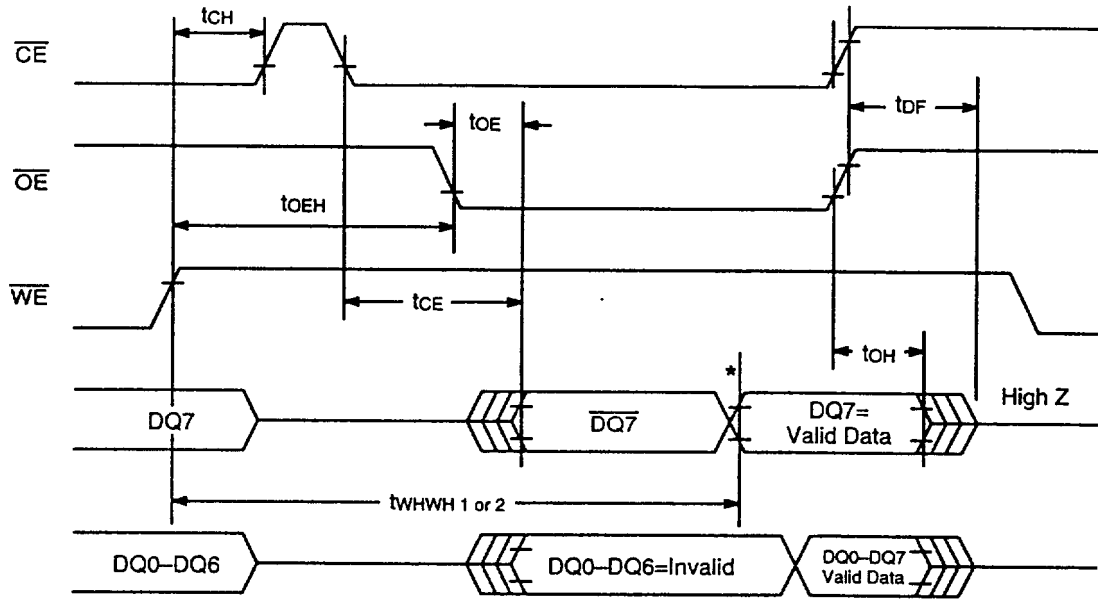

Figure 8. AC Waveforms for Read Operations Timing Diagram

19643A-12

SWITCHING WAVEFORMS



*DQ7=Valid Data (The device has completed the Embedded operation).

19643A-15

Figure 11. AC Waveforms for Data Polling During Embedded Algorithm Operations

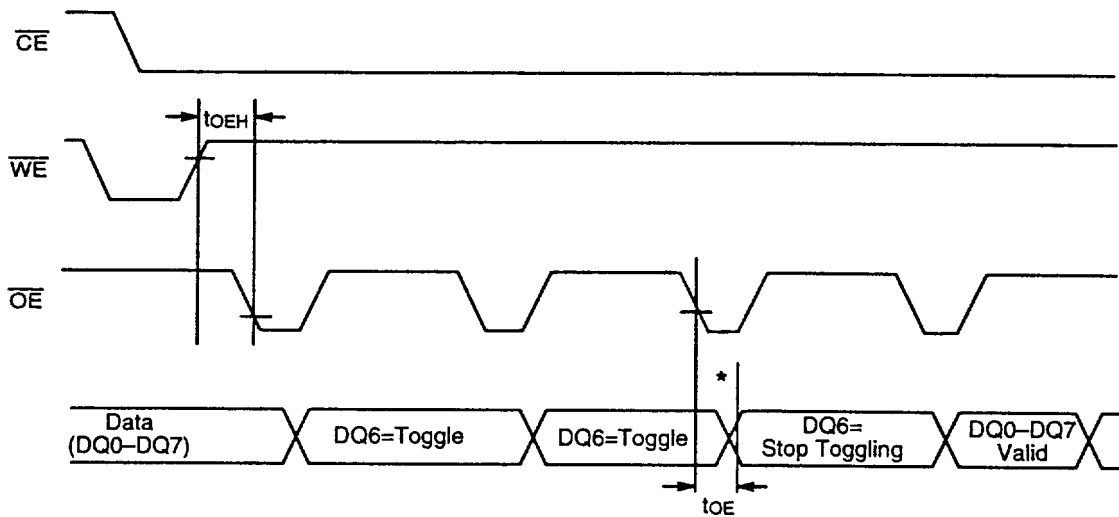

Note:

*DQ6 stops toggling (The device has completed the Embedded operation).

19643A-16

Figure 12. AC Waveforms for Toggle Bit I During Embedded Algorithm Operations

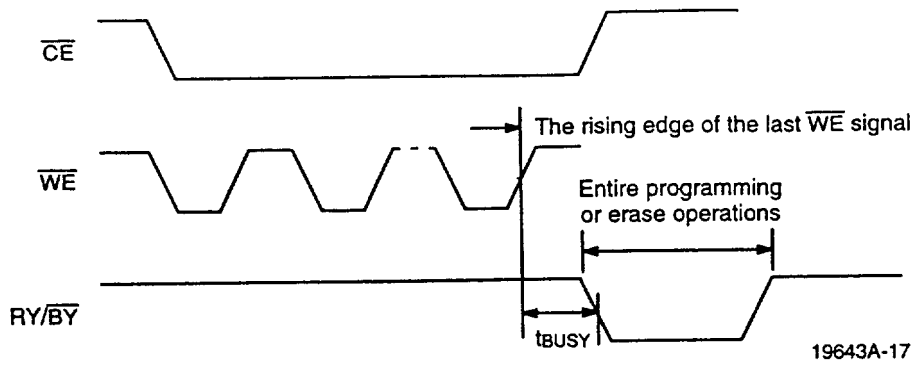

Figure 13. RY/\overline{BY} Timing Diagram During Program/Erase Operations

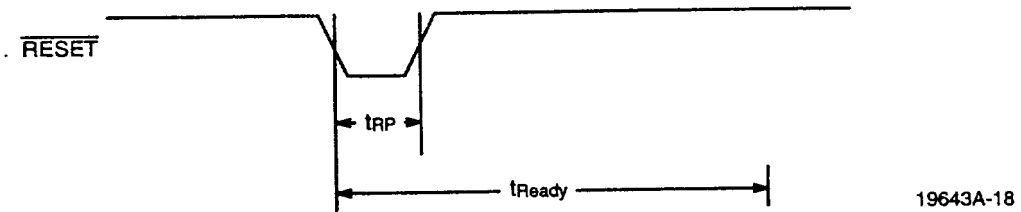
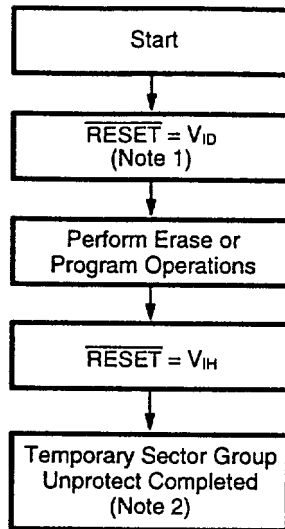

Figure 14. \overline{RESET} Timing Diagram



19643A-21

Notes:

1. All protected sector groups unprotected.
2. All previously protected sector groups are protected once again.

Figure 15. Temporary Sector Group Unprotect Algorithm

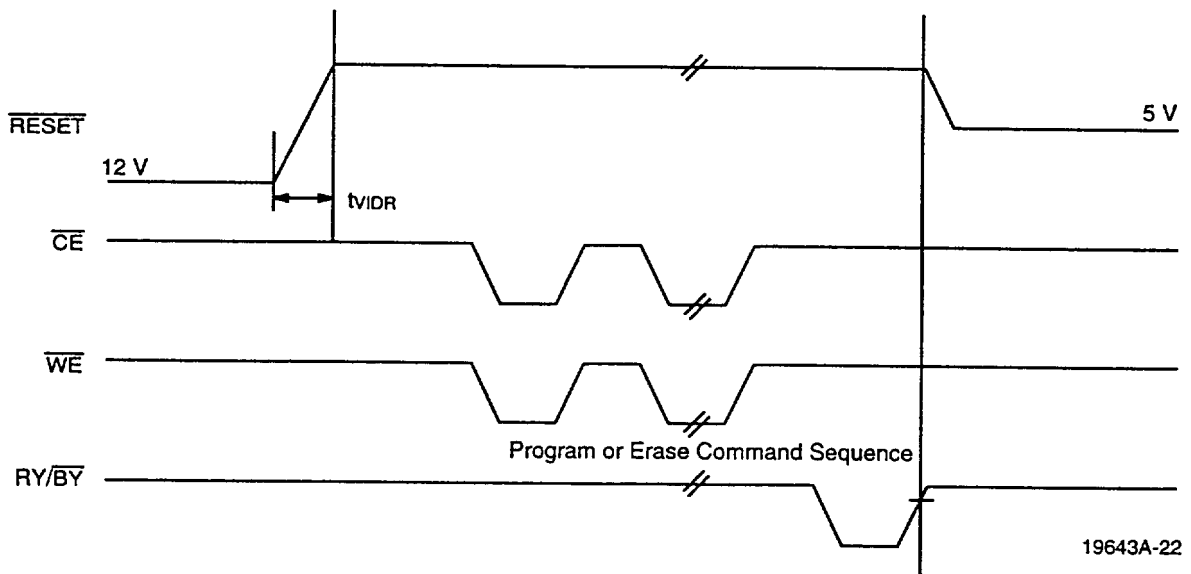

19643A-22

Figure 16. Temporary Sector Group Unprotect Timing Diagram

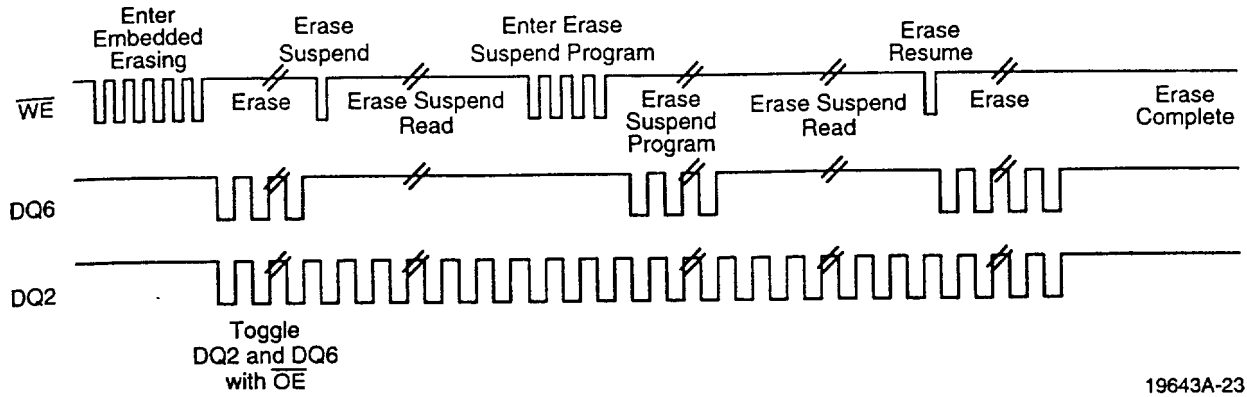

19643A-23

Note:
DQ2 is read from the erase-suspended sector.

Figure 17. DQ2 vs. DQ6

AC CHARACTERISTICS
Write/Erase/Program Operations
Alternate \overline{CE} Controlled Writes

Parameter Symbols		Description		-85	-90	-120	-150	Unit
JEDEC	Standard							
tAVAV	tWC	Write Cycle Time (Note 2)	Min	85	90	120	150	ns
tAVEL	tAS	Address Setup Time	Min	0	0	0	0	ns
tELAX	tAH	Address Hold Time	Min	40	45	50	50	ns
tDVEH	tDS	Data Setup Time	Min	40	45	50	50	ns
tEHDX	tDH	Data Hold Time	Min	0	0	0	0	ns
	tOES	Output Enable Setup Time (Note 2)	Min	0	0	0	0	ns
	tOEH	Output Enable Read (Note 2)	Min	0	0	0	0	ns
		Hold Time Toggle Bit 1 and \overline{Data} Polling (Note 2)	Min	10	10	10	10	ns
tGHEL	tGHEL	Read Recover Time Before Write	Min	0	0	0	0	ns
tWLEL	tWS	\overline{CE} Setup Time	Min	0	0	0	0	ns
tEHWH	tWH	\overline{CE} Hold Time	Min	0	0	0	0	ns
tELEH	tCP	Write Pulse Width	Min	40	45	50	50	ns
tEHEL	tCPH	Write Pulse Width High	Min	20	20	20	20	ns
tWHWH1	tWHWH1	Byte Programming Operation	Typ	8	8	8	8	μ s
tWHWH2	tWHWH2	Sector Erase Operation (Note 1)	Typ	1	1	1	1	sec
			Max	15	15	15	15	sec

Notes:

1. This does not include the preprogramming time.
2. Not 100% tested.

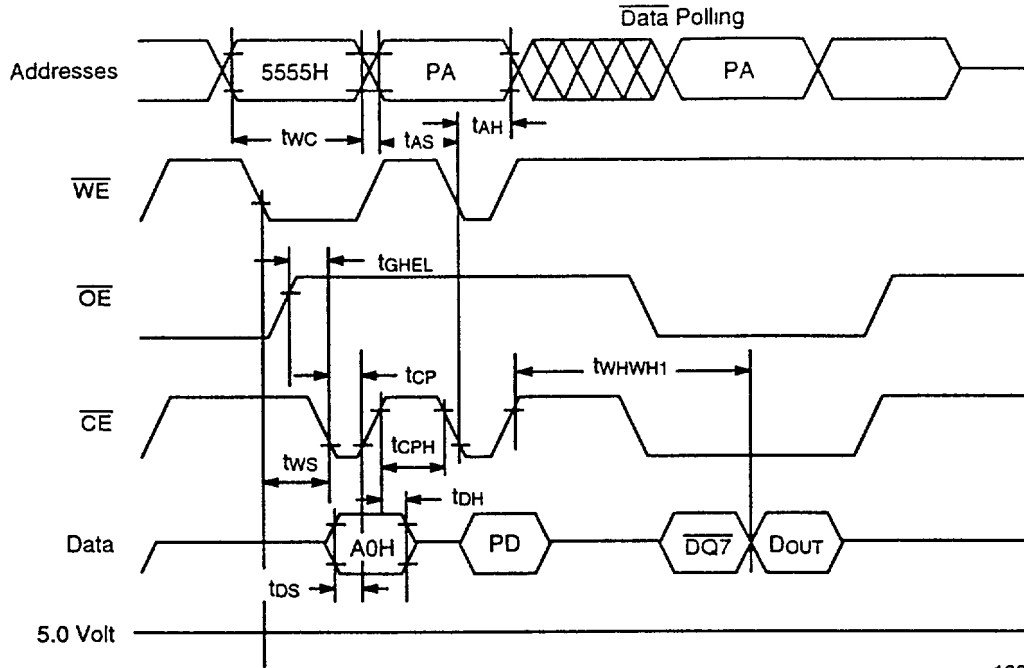

19643A-24

Notes:

1. PA is address of the memory location to be programmed.
2. PD is data to be programmed at byte address.
3. $\overline{DQ7}$ is the output of the complement of the data written to the device.
4. DOUT is the output of the data written to the device.
5. Figure indicates last two bus cycles of four bus cycle sequence.

Figure 18. Alternate \overline{CE} Controlled Program Operation Timings