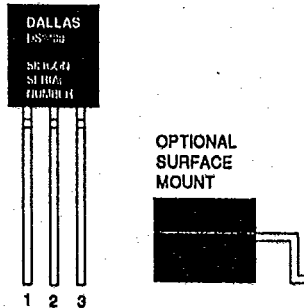

DALLAS
SEMICONDUCTOR**DS2400**
Silicon Serial Number

T-65-15

FEATURES

- Unique 48-bit silicon serial number gives 10^{14} combinations
- Factory lasered and tested, no two parts alike
- 8-bit cyclic redundancy check ensures error-free reading
- 8-bit model number references DS2400 communications requirements to system
- Presence detect indicates to the system when first contact is made
- Low-cost TO-92 package and optional surface mount option
- Reduces control, address, and data to a single pin
- Zero standby power required
- Directly connects to one port pin for microprocessor interface
- Pulse width measurement determines "1s" or "0s"
- Power derived from data line

PIN DESCRIPTION**PIN NAMES**

Pin 1	Ground
Pin 2	Data (DQ)
Pin 3	No Connect

DESCRIPTION

The DS2400 Silicon Serial Number is a device which contains an 8-bit model number, a unique 48-bit serial number, and an 8-bit cyclic redundancy check value embedded in silicon. Signal-

ing necessary for reading or writing is reduced to just one interface lead. The familiar TO-92 package provides a small, low-cost enclosure. Power for reading and writing is derived from the data line itself with no need for an external power source.

T-65-15

OPERATION

All communication to and from the DS2400 Silicon Serial Number is accomplished via a single interface lead. Data contained within the DS2400 is accessed through the use of time slots and a 1-wire protocol. Power to the part is derived from the high going pulse at the beginning of a write or read time slot.

WRITE TIME SLOTS

A write time slot is initiated when the system pulls the data line from a high logic level to a low logic level. There are two types of write time slots: write one and write zero. All write slots must be a minimum of 60 microseconds and a maximum of 120 microseconds in duration with a minimum of a 1 microsecond recovery time between individual write cycles.

For the system to generate a write one time slot, the data line must be pulled to a logic low level and then released, allowing the data line to pull up to a high level within 15 microseconds after the start of the write time slot (see Figure 1).

For the system to generate a write zero time slot, the data line must be pulled to a logic low level and remain low for the duration of the write time slot (see Figure 2).

READ TIME SLOTS

The system generates read time slots when data is to be read from the DS2400. A read time slot is initiated when the system pulls the data line from a logic high level to a logic low level. The data line must remain at a low logic level for a minimum of 1 microsecond and a maximum of 15 microseconds. This maximum time of 15 microseconds includes the time required for the data line to pull up to a high level after it is released. The state of the DS2400 data must be read by the system within 15 microseconds after the start of the read time slot. After this time, the state of the data is not guaranteed (see Figure 3). All read time slots must be a minimum of 60

microseconds in duration and a maximum of 120 microseconds in duration with a minimum of a 1 microsecond recovery time between individual read time slots.

1-WIRE PROTOCOL

To communicate with the DS2400 a specific protocol is utilized. The 1-wire protocol consists of four separate states which are used to reset the device, issue a command word, read the type identifier number, and read the unique silicon serial number and CRC byte (see Figure 4).

To initially set the DS2400 into a known state, a reset pulse must be sent to it. The reset pulse is a logic low generated by the system which must remain low for a minimum of 480 microseconds and then be followed by a 480 microsecond logic high level (see Figure 5). During this 480 microsecond high time the DS2400 will assert a presence detect signal. This signal is generated by the DS2400 and consists of a logic low level which is held for a maximum of 240 microseconds and minimum of 60 microseconds. This signal can be used to detect that a DS2400 is attached to the 1-wire interface after the issuance of a reset command.

Once the DS2400 has been set into a known state, the command word is transmitted to the DS2400 with eight write time slots. The command word for the DS2400 is a hexadecimal **0F**.

Upon recognition of the command word the DS2400 is ready to respond to the next eight read time slots with the type identifier number. This number is a hexadecimal **01**.

After receipt by the system of the type identifier number the DS2400 is ready to output the unique 48-bit serial number contained within the device. The system must issue 48 read time slots to retrieve this number. Following the 48-bit serial number is an eight-bit cyclic redundancy check value. This CRC value has been

T-65-15

calculated over the type identifier and serial number (56 bits) and is lasered into the part at the time of manufacture. To read the CRC value the system must issue eight read time slots. To stop reading at any time the system can issue a reset pulse.

CRC GENERATION

To validate that the transmitted data from the DS2400 has been received correctly by the system a comparison of the system-generated CRC and the received DS2400 CRC must be made. If the two CRC values match, the transmission was error-free. An example of how to generate the CRC using software is shown in Table 1. This assembly language code is written for the DS5000 Soft Microcontroller. The assembly language procedure **DO_CRC** given below calculates the cumulative CRC of all the bytes passed to it in the accumulator. Before it is used to calculate the CRC of a data stream, it

should be initialized by setting the variable **CRC** to zero. Each byte of the data is then placed in the accumulator and **DO_CRC** is called to update the CRC variable. After all the data has been passed to **DO_CRC**, the variable **CRC** will contain the result.

RECOMMENDED SYSTEM INTERFACE

The system must have an open drain driver with a pullup resistor of approximately 5K ohms to Vcc on the data signal line. The DS2400 has an internal open drain driver with a 500K ohm pulldown resistor to ground. The pulldown resistor holds the data input pin at ground potential when the DS2400 is not connected to a 1-wire interface (see Figure 6).

ASSEMBLY LANGUAGE PROCEDURE Table 1

DO_CRC:	PUSH ACC	; save the accumulator
	PUSH B	; save the B register
	PUSH ACC	; save bits to be shifted
	MOV B,#8	; set shift = 8 bits
		:
CRC_LOOP:	XRL A,CRC	; calculate CRC
	RRC A	; move it to the carry
	MOV A,CRC	; get the last CRC value
	JNC ZERO	; skip if data = 0
	XRL A,#18H	; update the CRC value
		:
ZERO:	RRC A	; position the new CRC
	MOV CRC,A	; store the new CRC
	POP ACC	; get the remaining bits
	RR A	; position the next bit
	PUSH ACC	; save the remaining bits
	DJNZ B,CRC_LOOP	; repeat for eight bits
	POP ACC	; clean up the stack
	POP B	; restore the B register
	POP ACC	; restore the accumulator
	RET	

T-65-15

WRITE ONE TIME SLOT Figure 1

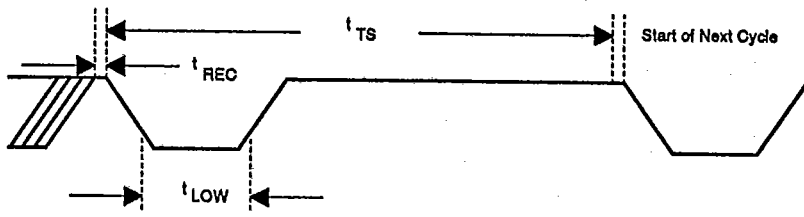

WRITE ZERO TIME SLOT Figure 2

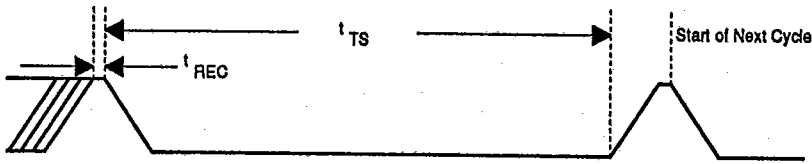

READ DATA TIME SLOTS Figure 3

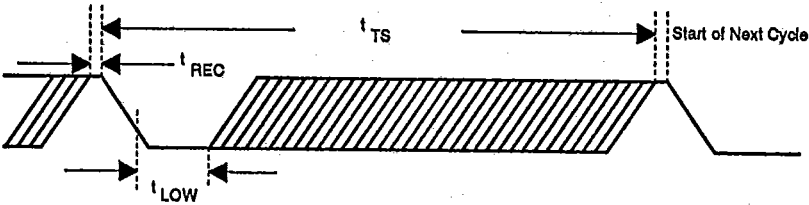

1-WIRE PROTOCOL Figure 4

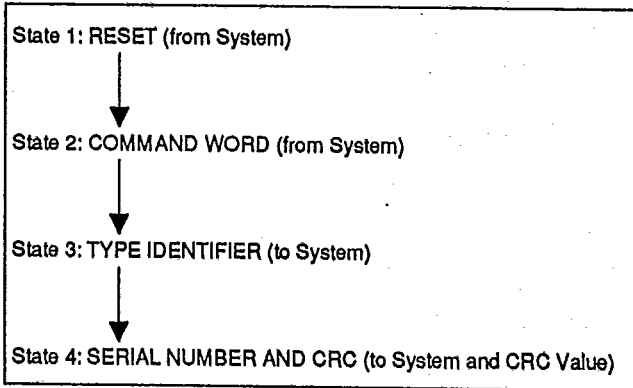

RESET PULSE/PRESENCE DETECT Figure 5

T-65-15

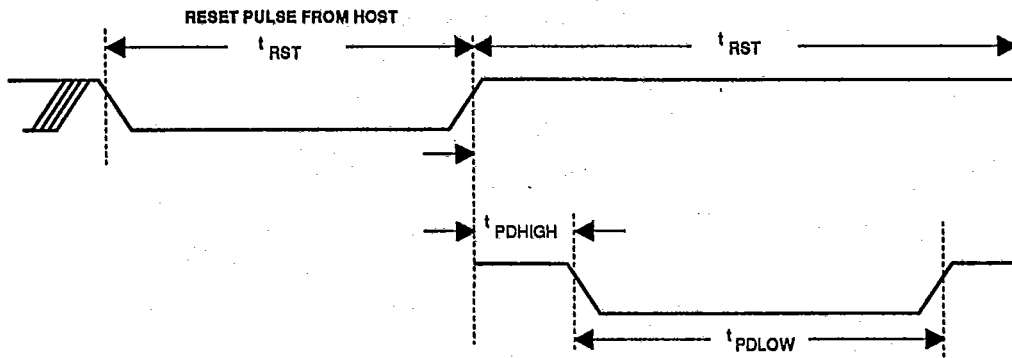

RECOMMENDED SYSTEM TO DS2400 INTERFACE Figure 6

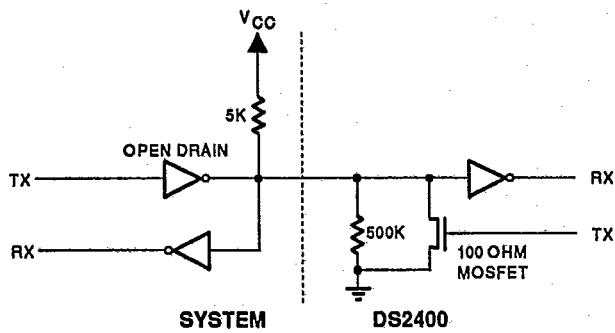

T-65-15

ABSOLUTE MAXIMUM RATINGS*

Voltage On Data Pin Relative to Ground
 Operating Temperature
 Storage Temperature

-0.5 to +7V
 0°C to 70°C
 -55°C to +125°C

*This is a stress rating only and functional operation of the device at these or any other conditions above those indicated in the operation sections of this specification is not implied. Exposure to absolute maximum rating conditions for extended periods of time may affect reliability.

RECOMMENDED DC OPERATING CONDITIONS

(0°C To 70°C)

PARAMETER	SYMBOL	MIN.	TYP.	MAX.	UNITS	NOTES
Data Pin	DQ	-0.5		5.5	Volts	1

DC ELECTRICAL CHARACTERISTICS(V_{CC} = 5V +/- 10%, 0°C To 70°C)

PARAMETER	SYMBOL	MIN.	TYP.	MAX.	UNITS	NOTES
Input Logic Low	V _{IL}	-0.5		0.4	Volts	1,6
Input Logic High	V _{IH}	3.0	5.0	5.5	Volts	1,6,7
Sink Current	I _L	-1.0			mA	4,6
Output Logic Low	V _{OL}			0.4	Volts	3,6
Output Logic High	V _{OH}			5.5	Volts	3,6
Input Resistance	I _R	500K				2
Operating Charge	I _{OP}			30	NC	5,6

NOTES:

- All voltages are referenced to ground.
- Input is pulled to ground.
- @1 mA.
- @ V_{OUT} = 0.4V.
- 30 nanocoulombs per 72 time slots @ 5.0V.
- @ V_{CC} = 5.0 volts with a 5K pullup to V_{CC} and a maximum time slot of 120 us.
- V_{IH} is a function of the external pullup resistor and the V_{CC} supply.

T-65-15

AC ELECTRICAL CHARACTERISTICS

 $(V_{CC} = 5V \pm 10\%, 0^{\circ}C \text{ to } 70^{\circ}C)$

PARAMETER	SYMBOL	MIN.	TYP.	MAX.	UNITS	NOTES
Time Slot	t_{TS}	60		120	μS	
Recovery Time Between Time Slots	t_{REC}	1			μS	
Low Time (generated for write one and read time slots)	t_{LOW}	1		15	μS	
Reset Time	t_{RST}	480			μS	
Presence Detect High Time (generated by DS2400 during presence detect cycle)	t_{PDHIGH}	15		60	μS	
Presence Detect Low Time (Generated by DS2400 during presence detect cycle)	t_{PDLOW}	60		240	μS	