

SIEMENS

Microcomputer Components

8-Bit CMOS Microcontroller

C515C

Data Sheet 07.97

This Material Copyrighted By Its Respective Manufacturer

C515C Data Sheet	
Revision History :	1997-07-01
Previous Releases :	09.96
Page	Subjects (changes since last revision)
4	SSC transfer rate at 10 MHz = 2.5 MHz
19	Figure reference corrected
52, 53	Power saving modes : description of hardware power down mode added
56, 57	Icc specification has been extended
62	t _{SCLK} for Master Mode corrected

Edition 1997-07-01

**Published by Siemens AG,
Bereich Halbleiter, Marketing-
Kommunikation, Balanstraße 73,
81541 München**

© Siemens AG 1997.
All Rights Reserved.

Attention please!

As far as patents or other rights of third parties are concerned, liability is only assumed for components, not for applications, processes and circuits implemented within components or assemblies.

The information describes the type of component and shall not be considered as assured characteristics.

Terms of delivery and rights to change design reserved.

For questions on technology, delivery and prices please contact the Semiconductor Group Offices in Germany or the Siemens Companies and Representatives worldwide (see address list).

Due to technical requirements components may contain dangerous substances. For information on the types in question please contact your nearest Siemens Office, Semiconductor Group.

Siemens AG is an approved CECC manufacturer.

Packing

Please use the recycling operators known to you. We can also help you – get in touch with your nearest sales office. By agreement we will take packing material back, if it is sorted. You must bear the costs of transport.

For packing material that is returned to us unsorted or which we are not obliged to accept, we shall have to invoice you for any costs incurred.

Components used in life-support devices or systems must be expressly authorized for such purpose!

Critical components¹ of the Semiconductor Group of Siemens AG, may only be used in life-support devices or systems² with the express written approval of the Semiconductor Group of Siemens AG.

- 1 A critical component is a component used in a life-support device or system whose failure can reasonably be expected to cause the failure of that life-support device or system, or to affect its safety or effectiveness of that device or system.
- 2 Life support devices or systems are intended (a) to be implanted in the human body, or (b) to support and/or maintain and sustain human life. If they fail it is reasonable to assume that the health of the user may be endangered.

Advance Information

- Full upward compatibility with SAB 80C515A
- 64k byte on-chip ROM (external program execution is possible)
- 256 byte on-chip RAM
- 2K byte of on-chip XRAM
- Up to 64K byte external data memory
- Superset of the 8051 architecture with 8 datapointers
- Up to 10 MHz external operating frequency (1 μ s instruction cycle time at 6 MHz external clock)
- On-chip emulation support logic (Enhanced Hooks Technology™)
- Current optimized oscillator circuit and EMI optimized design
- Eight ports : 48+1 digital I/O lines, 8 analog inputs
 - Quasi-bidirectional port structure (8051 compatible)
 - Port 5 selectable for bidirectional port structure (CMOS voltage levels)
- Full-CAN controller on-chip
 - 256 register/data bytes are located in external data memory area
 - max.1 Mbaud at 8-10 MHz operating frequency
- Three 16-bit timer/counters
 - Timer 2 can be used for compare/capture functions

(further features are on next page)

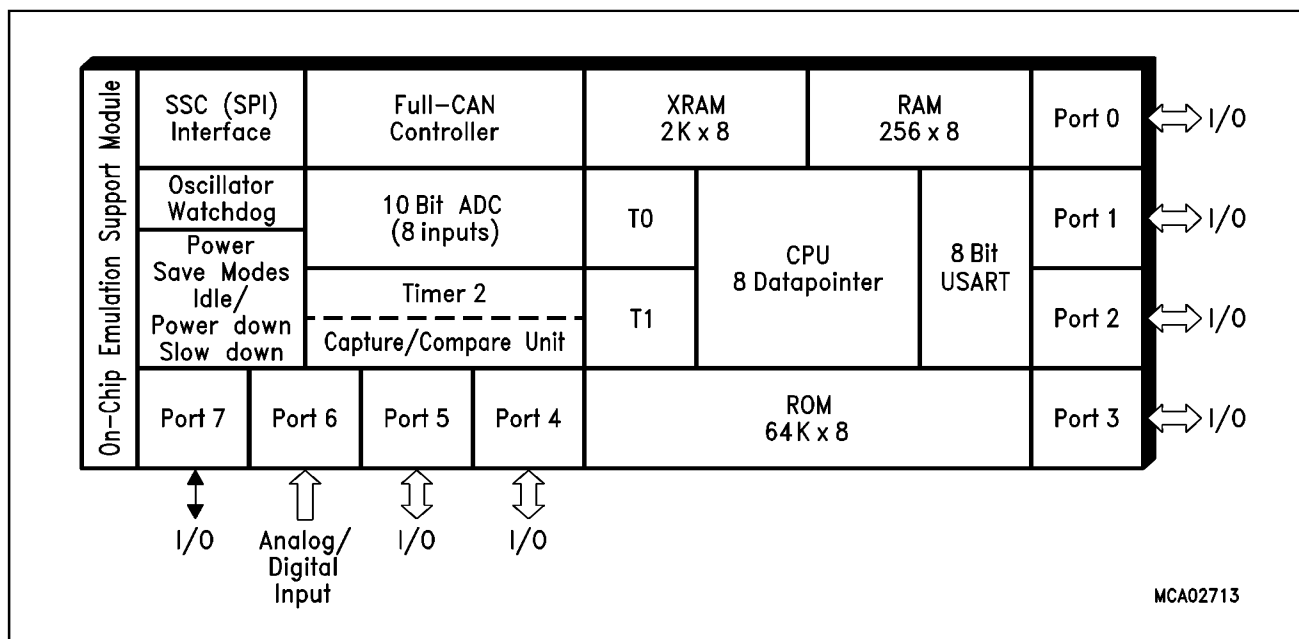

Figure 1
C515C Functional Units

Enhanced Hooks Technology™ is a trademark of Siemens AG.

Features (continued) :

- 10-bit A/D converter with multiplexed inputs and built-in self calibration
- Full duplex serial interface with programmable baudrate generator (USART)
- SSC synchronous serial interface (SPI compatible)
 - Master and slave capable
 - Programmable clock polarity / clock-edge to data phase relation
 - LSB/MSB first selectable
 - 2.5 MHz transfer rate at 10 MHz operating frequency
- Seventeen interrupt vectors, at four priority levels selectable
- Extended watchdog facilities
 - 15-bit programmable watchdog timer
 - Oscillator watchdog
- Power saving modes
 - Slow-down mode
 - Idle mode (can be combined with slow-down mode)
 - Software power-down mode with wake-up capability through $\overline{\text{INT0}}$ pin
 - Hardware power-down mode
- CPU running condition output pin
- ALE can be switched off
- Multiple separate VCC/VSS pin pairs
- P-MQFP-80-1 package
- Temperature Ranges :

SAB-C515C-8R	$T_A = 0$ to 70 °C
SAF-C515C-8R	$T_A = -40$ to 85 °C
SAH-C515C-8R	$T_A = -40$ to 110 °C

The C515C is an enhanced, upgraded version of the SAB 80C515A 8-bit microcontroller which additionally provides a full CAN interface, a SPI compatible synchronous serial interface, extended power save provisions, additional on-chip RAM, 64K of on-chip program memory, two new external interrupts and RFI related improvements. With a maximum external clock rate of 10 MHz it achieves a 600 ns instruction cycle time (1 μ s at 6 MHz). The C515C is mounted in a P-MQFP-80 package.

Ordering Information

Type	Ordering Code	Package	Description (8-Bit CMOS microcontroller)
SAB-C515C-LM	Q67121-C1066	P-MQFP-80-1	for external memory (10 MHz)
SAF-C515C-LM	Q67121-C1058	P-MQFP-80-1	for external memory (10 MHz) ext. temp. – 40 °C to 85 °C
SAB-C515C-8RM	Q67121-DXXXX	P-MQFP-80-1	with mask programmable ROM (10 MHz)
SAF-C515C-8RM	Q67121-DXXXX	P-MQFP-80-1	with mask programmable ROM (10 MHz) ext. temp. – 40 °C to 85 °C

Note: Versions for extended temperature ranges – 40 °C to 110 °C (SAH-C515C-LM and SAH-C515C-8RM) are available on request. The ordering number of ROM types (DXXXX extensions) is defined after program release (verification) of the customer.

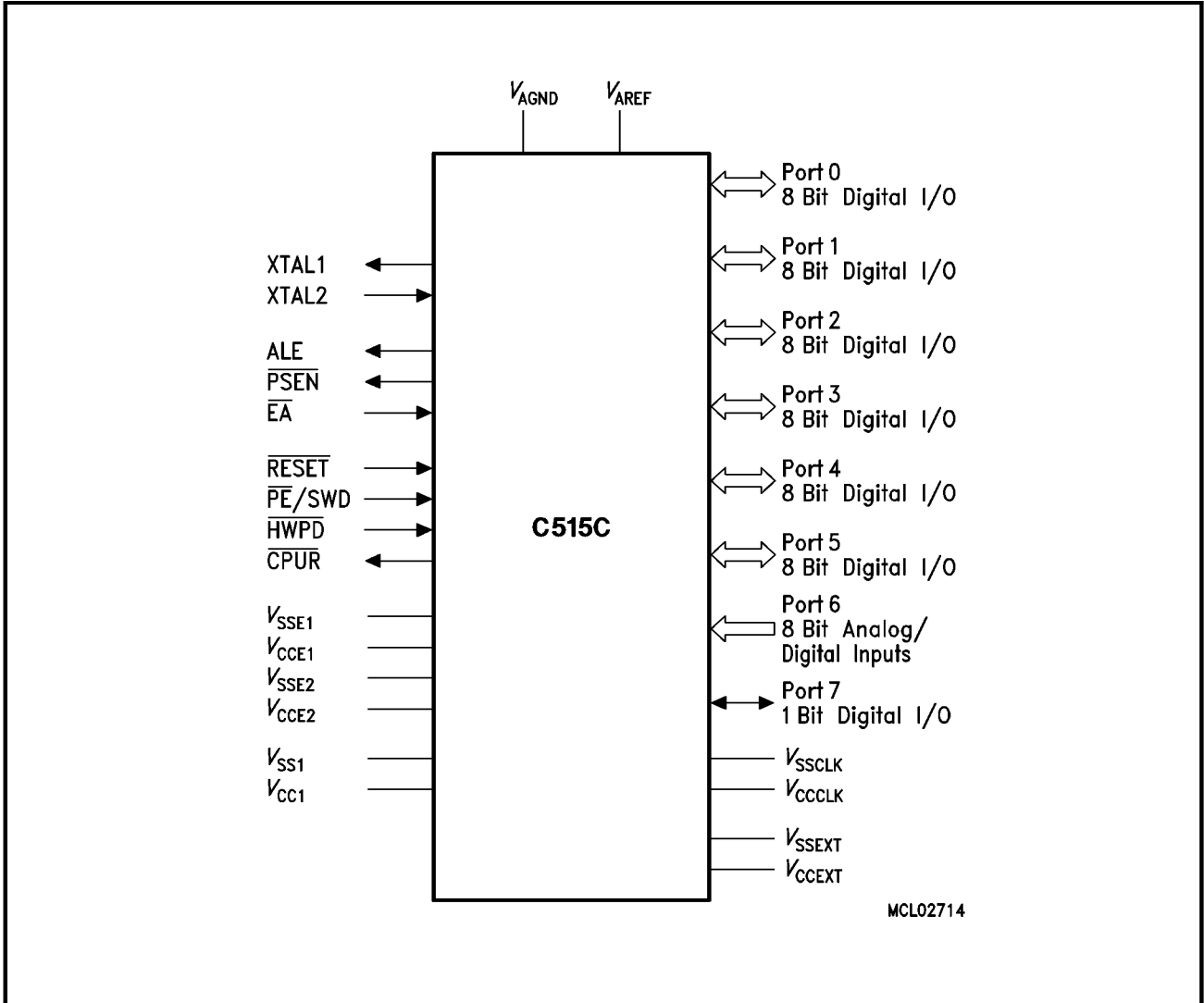
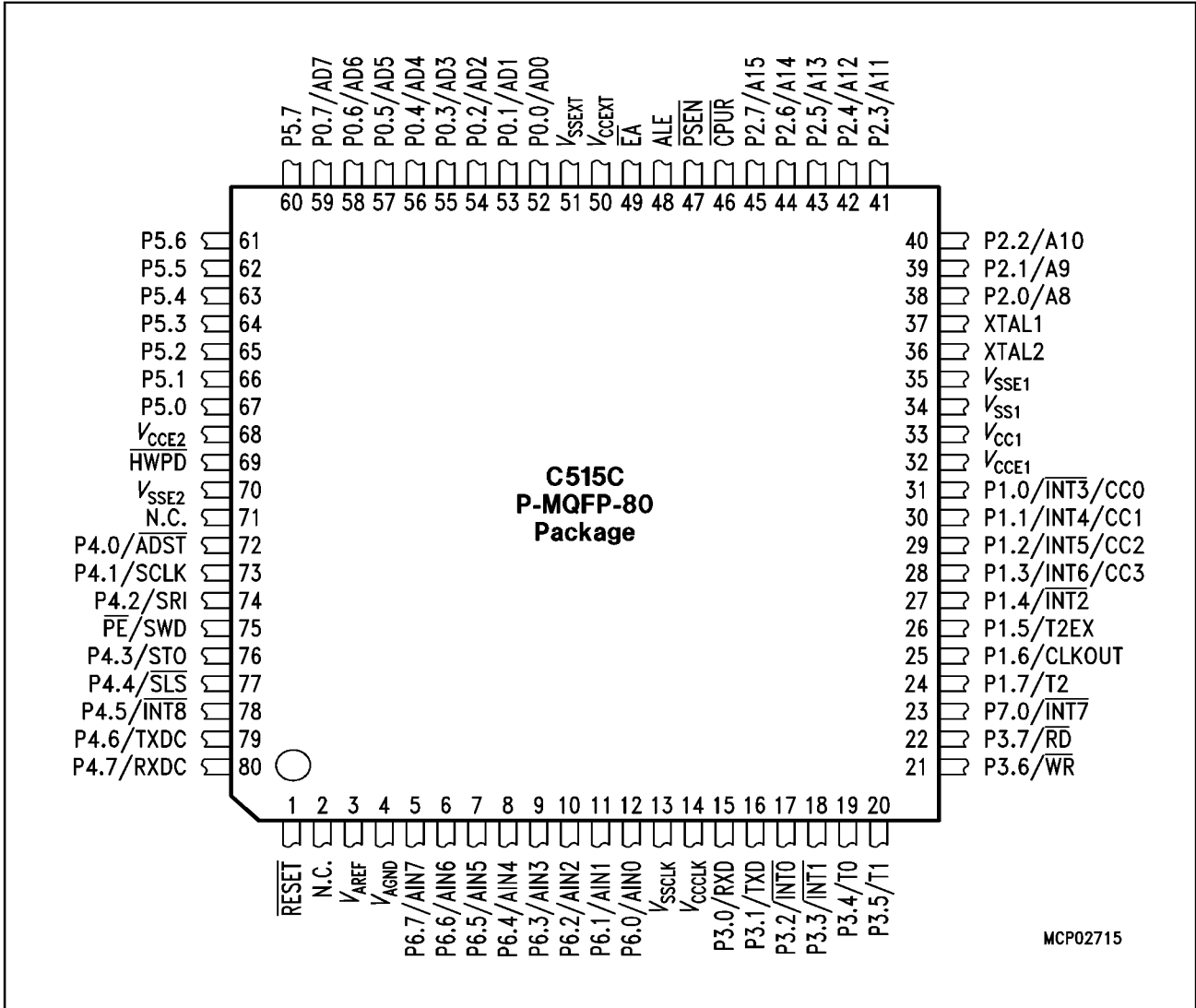

Figure 2
Logic Symbol



MCP02715

Figure 3
C515C Pin Configuration (P-MQFP-80-1, Top View)

Table 1
Pin Definitions and Functions

Symbol	Pin Number	I/O*)	Function
	P-MQFP-80		
RESET	1	I	RESET A low level on this pin for the duration of two machine cycles while the oscillator is running resets the C515C. A small internal pullup resistor permits power-on reset using only a capacitor connected to VSS.
VAREF	3	–	Reference voltage for the A/D converter
VAGND	4	–	Reference ground for the A/D converter
P6.0-P6.7	12-5	I	Port 6 is an 8-bit unidirectional input port to the A/D converter. Port pins can be used for digital input, if voltage levels simultaneously meet the specifications high/low input voltages and for the eight multiplexed analog inputs.

*) I = Input
O = Output

Table 1
Pin Definitions and Functions (cont'd)

Symbol	Pin Number	I/O*	Function
	P-MQFP-80		
P3.0-P3.7	15-22	I/O	Port 3 is an 8-bit quasi-bidirectional I/O port with internal pullup resistors. Port 3 pins that have 1's written to them are pulled high by the internal pullup resistors, and in that state can be used as inputs. As inputs, port 3 pins being externally pulled low will source current (I_{IL} , in the DC characteristics) because of the internal pullup resistors. Port 3 also contains the interrupt, timer, serial port and external memory strobe pins that are used by various options. The output latch corresponding to a secondary function must be programmed to a one (1) for that function to operate. The secondary functions are assigned to the pins of port 3, as follows:
	15	P3.0	RXD Receiver data input (asynch.) or data input/output (synch.) of serial interface
	16	P3.1	TXD Transmitter data output (asynch.) or clock output (synch.) of serial interface
	17	P3.2	$\overline{INT0}$ External interrupt 0 input / timer 0 gate control input
	18	P3.3	$\overline{INT1}$ External interrupt 1 input / timer 1 gate control input
	19	P3.4	T0 Timer 0 counter input
	20	P3.5	T1 Timer 1 counter input
	21	P3.6	\overline{WR} \overline{WR} control output; latches the data byte from port 0 into the external data memory
22	P3.7	\overline{RD} \overline{RD} control output; enables the external data memory	

*) I = Input
O = Output

Table 1
Pin Definitions and Functions (cont'd)

Symbol	Pin Number	I/O*	Function
	P-MQFP-80		
P7.0 / $\overline{\text{INT7}}$	23	I/O	<p>Port 7 is an 1-bit quasi-bidirectional I/O port with internal pull-up resistor. When a 1 is written to P7.0 it is pulled high by an internal pull-up resistor, and in that state can be used as input. As input, P7.0 being externally pulled low will source current (I_{IL}, in the DC characteristics) because of the internal pull-up resistor. If P7.0 is used as interrupt input, its output latch must be programmed to a one (1). The secondary function is assigned to the port 7 pin as follows: P7.0 $\overline{\text{INT7}}$ Interrupt 7 input</p>
P1.0 - P1.7	31-24	I/O	<p>Port 1 is an 8-bit quasi-bidirectional I/O port with internal pullup resistors. Port 1 pins that have 1's written to them are pulled high by the internal pullup resistors, and in that state can be used as inputs. As inputs, port 1 pins being externally pulled low will source current (I_{IL}, in the DC characteristics) because of the internal pullup resistors. The port is used for the low-order address byte during program verification. Port 1 also contains the interrupt, timer, clock, capture and compare pins that are used by various options. The output latch corresponding to a secondary function must be programmed to a one (1) for that function to operate (except when used for the compare functions). The secondary functions are assigned to the port 1 pins as follows:</p>
	31		P1.0 $\overline{\text{INT3}}$ CC0 Interrupt 3 input / compare 0 output / capture 0 input
	30		P1.1 INT4 CC1 Interrupt 4 input / compare 1 output / capture 1 input
	29		P1.2 INT5 CC2 Interrupt 5 input / compare 2 output / capture 2 input
	28		P1.3 INT6 CC3 Interrupt 6 input / compare 3 output / capture 3 input
	27		P1.4 $\overline{\text{INT2}}$ Interrupt 2 input
	26		P1.5 T2EX Timer 2 external reload / trigger input
	25		P1.6 CLKOUT System clock output
	24		P1.7 T2 Counter 2 input

*) I = Input
O = Output

Table 1
Pin Definitions and Functions (cont'd)

Symbol	Pin Number	I/O*	Function
	P-MQFP-80		
XTAL2	36	I	<p>XTAL2 Input to the inverting oscillator amplifier and input to the internal clock generator circuits. To drive the device from an external clock source, XTAL2 should be driven, while XTAL1 is left unconnected. Minimum and maximum high and low times as well as rise/fall times specified in the AC characteristics must be observed.</p>
XTAL1	37	O	<p>XTAL1 Output of the inverting oscillator amplifier.</p>
P2.0-P2.7	38-45	I/O	<p>Port 2 is an 8-bit quasi-bidirectional I/O port with internal pullup resistors. Port 2 pins that have 1's written to them are pulled high by the internal pullup resistors, and in that state can be used as inputs. As inputs, port 2 pins being externally pulled low will source current (I_{IL}, in the DC characteristics) because of the internal pullup resistors. Port 2 emits the high-order address byte during fetches from external program memory and during accesses to external data memory that use 16-bit addresses (MOVX @DPTR). In this application it uses strong internal pullup resistors when issuing 1's. During accesses to external data memory that use 8-bit addresses (MOVX @Ri), port 2 issues the contents of the P2 special function register.</p>
$\overline{\text{CPUR}}$	46	O	<p>CPU running condition This output pin is at low level when the CPU is running and program fetches or data accesses in the external data memory area are executed. In idle mode, hardware and software power down mode, and with an active $\overline{\text{RESET}}$ signal $\overline{\text{CPUR}}$ is set to high level. $\overline{\text{CPUR}}$ can be typically used for switching external memory devices into power saving modes.</p>

*) I = Input
O = Output

Table 1
Pin Definitions and Functions (cont'd)

Symbol	Pin Number	I/O*	Function
	P-MQFP-80		
$\overline{\text{PSEN}}$	47	O	The Program Store Enable output is a control signal that enables the external program memory to the bus during external fetch operations. It is activated every six oscillator periods, except during external data memory accesses. The signal remains high during internal program execution.
ALE	48	O	The Address Latch enable output is used for latching the address into external memory during normal operation. It is activated every six oscillator periods, except during an external data memory access. ALE can be switched off when the program is executed internally.
$\overline{\text{EA}}$	49	I	External Access Enable When held high, the C515C executes instructions always from the internal ROM. When held low, the C515C fetches all instructions from external program memory.
P0.0-P0.7	52-59	I/O	Port 0 is an 8-bit open-drain bidirectional I/O port. Port 0 pins that have 1's written to them float, and in that state can be used as high-impedance inputs. Port 0 is also the multiplexed low-order address and data bus during accesses to external program and data memory. In this application it uses strong internal pullup resistors when issuing 1's. Port 0 also outputs the code bytes during program verification in the C515C. External pullup resistors are required during program verification.
P5.0-P5.7	67-60	I/O	Port 5 is an 8-bit quasi-bidirectional I/O port with internal pullup resistors. Port 5 pins that have 1's written to them are pulled high by the internal pullup resistors, and in that state can be used as inputs. As inputs, port 5 pins being externally pulled low will source current (I_{IL} , in the DC characteristics) because of the internal pullup resistors. Port 5 can also be switched into a bidirectional mode, in which CMOS levels are provided. In this bidirectional mode, each port 5 pin can be programmed individually as input or output.

*) I = Input
 O = Output

Table 1
Pin Definitions and Functions (cont'd)

Symbol	Pin Number	I/O*	Function																								
	P-MQFP-80																										
HWP \overline{D}	69	I	<p>Hardware Power Down</p> <p>A low level on this pin for the duration of one machine cycle while the oscillator is running resets the C515C. A low level for a longer period will force the part to power down mode with the pins floating.</p>																								
P4.0-P4.7	72-74, 76-80	I/O	<p>Port 4</p> <p>is an 8-bit quasi-bidirectional I/O port with internal pull-up resistors. Port 4 pins that have 1's written to them are pulled high by the internal pull-up resistors, and in that state can be used as inputs. As inputs, port 4 pins being externally pulled low will source current (I_{IL}, in the DC characteristics) because of the internal pull-up resistors. P4 also contains the external A/D converter control pin, the SSC pins, the CAN controller input/output lines, and the external interrupt 8 input. The output latch corresponding to a secondary function must be programmed to a one (1) for that function to operate. The alternate functions are assigned to port 4 as follows:</p> <table border="0"> <tr> <td>P4.0</td> <td>\overline{ADST}</td> <td>External A/D converter start pin</td> </tr> <tr> <td>P4.1</td> <td>SCLK</td> <td>SSC Master Clock Output / SSC Slave Clock Input</td> </tr> <tr> <td>P4.2</td> <td>SRI</td> <td>SSC Receive Input</td> </tr> <tr> <td>P4.3</td> <td>STO</td> <td>SSC Transmit Output</td> </tr> <tr> <td>P4.4</td> <td>\overline{SLS}</td> <td>Slave Select Input</td> </tr> <tr> <td>P4.5</td> <td>$\overline{INT8}$</td> <td>External interrupt 8 input</td> </tr> <tr> <td>P4.6</td> <td>TXDC</td> <td>Transmitter output of the CAN controller</td> </tr> <tr> <td>P4.7</td> <td>RXDC</td> <td>Receiver input of the CAN controller</td> </tr> </table>	P4.0	\overline{ADST}	External A/D converter start pin	P4.1	SCLK	SSC Master Clock Output / SSC Slave Clock Input	P4.2	SRI	SSC Receive Input	P4.3	STO	SSC Transmit Output	P4.4	\overline{SLS}	Slave Select Input	P4.5	$\overline{INT8}$	External interrupt 8 input	P4.6	TXDC	Transmitter output of the CAN controller	P4.7	RXDC	Receiver input of the CAN controller
P4.0	\overline{ADST}	External A/D converter start pin																									
P4.1	SCLK	SSC Master Clock Output / SSC Slave Clock Input																									
P4.2	SRI	SSC Receive Input																									
P4.3	STO	SSC Transmit Output																									
P4.4	\overline{SLS}	Slave Select Input																									
P4.5	$\overline{INT8}$	External interrupt 8 input																									
P4.6	TXDC	Transmitter output of the CAN controller																									
P4.7	RXDC	Receiver input of the CAN controller																									
PE/SWD	75	I	<p>Power saving mode enable / Start watchdog timer</p> <p>A low level on this pin allows the software to enter the power down, idle and slow down mode. In case the low level is also seen during reset, the watchdog timer function is off on default.</p> <p>Use of the software controlled power saving modes is blocked, when this pin is held on high level. A high level during reset performs an automatic start of the watchdog timer immediately after reset. When left unconnected this pin is pulled high by a weak internal pull-up resistor.</p>																								

*) I = Input
O = Output

Table 1
Pin Definitions and Functions (cont'd)

Symbol	Pin Number	I/O*	Function
	P-MQFP-80		
VSSCLK	13	–	Ground (0 V) for on-chip oscillator This pin is used for ground connection of the on-chip oscillator circuit.
VCCCLK	14	–	Supply voltage for on-chip oscillator This pin is used for power supply of the on-chip oscillator circuit.
VCCE1 VCCE2	32 68	–	Supply voltage for I/O ports These pins are used for power supply of the I/O ports during normal, idle, and power-down mode.
VSSE1 VSSE2	35 70	–	Ground (0 V) for I/O ports These pins are used for ground connections of the I/O ports during normal, idle, and power-down mode.
VCC1	33	–	Supply voltage for internal logic This pins is used for the power supply of the internal logic circuits during normal, idle, and power down mode.
VSS1	34	–	Ground (0 V) for internal logic This pin is used for the ground connection of the internal logic circuits during normal, idle, and power down mode.
VCCEXT	50	–	Supply voltage for external access pins This pin is used for power supply of the I/O ports and control signals which are used during external accesses (for Port 0, Port 2, ALE, PSEN, P3.6/WR, and P3.7/RD).
VSSEXT	51	–	Ground (0 V) for external access pins This pin is used for the ground connection of the I/O ports and control signals which are used during external accesses (for Port 0, Port 2, ALE, PSEN, P3.6/WR, and P3.7/RD).
N.C.	2, 71	–	Not connected These pins should not be connected.

*) I = Input
O = Output

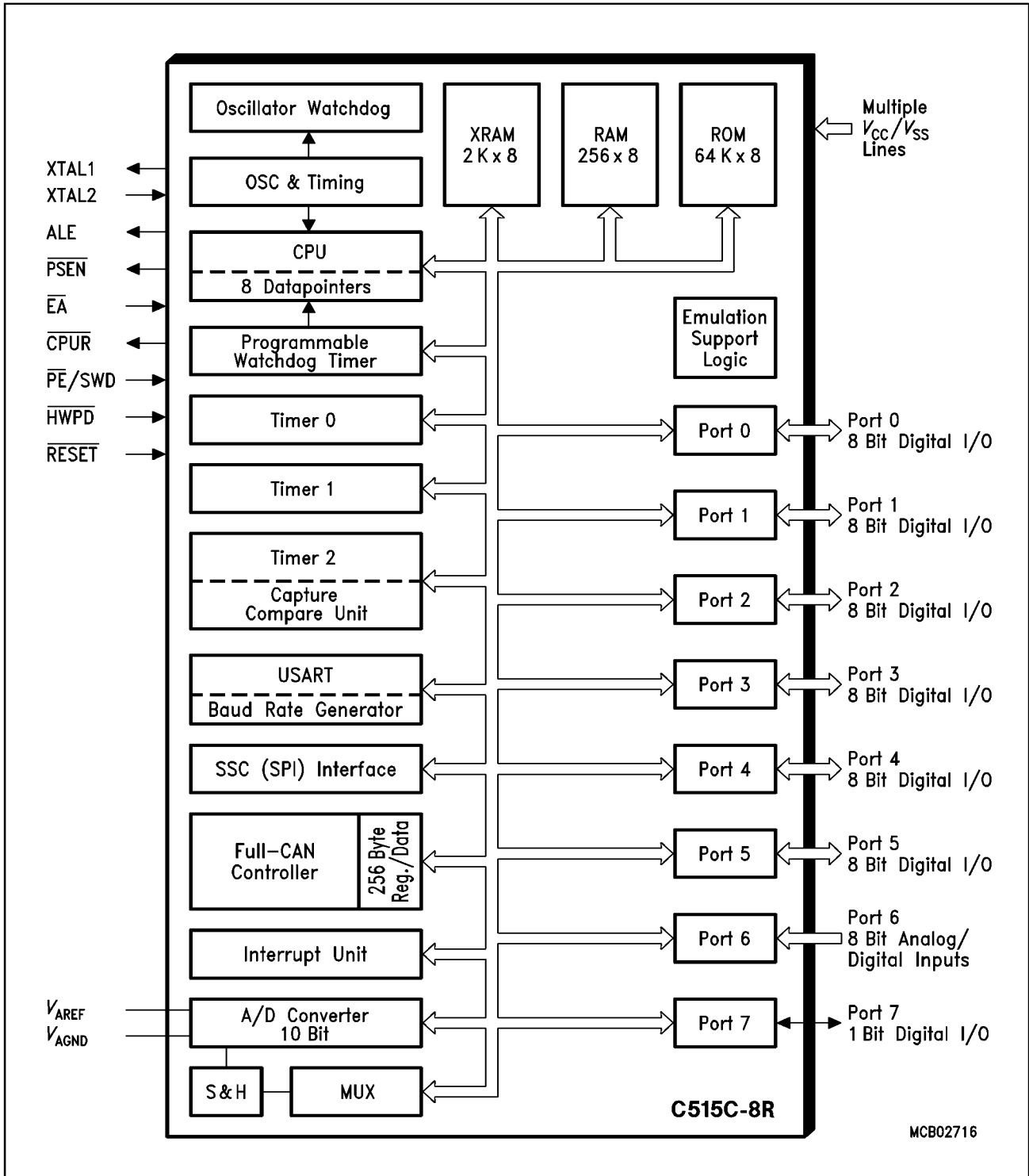

Figure 4
Block Diagram of the C515C

CPU

The C515C is efficient both as a controller and as an arithmetic processor. It has extensive facilities for binary and BCD arithmetic and excels in its bit-handling capabilities. Efficient use of program memory results from an instruction set consisting of 44 % one-byte, 41 % two-byte, and 15% three-byte instructions. With a 6 MHz crystal, 58% of the instructions are executed in 1 μ s (10 MHz : 600 ns).

Special Function Register PSW (Address D0_H)

Reset Value : 00_H

Bit No.	MSB								LSB
	D7 _H	D6 _H	D5 _H	D4 _H	D3 _H	D2 _H	D1 _H	D0 _H	
D0 _H	CY	AC	F0	RS1	RS0	OV	F1	P	PSW

Bit	Function															
CY	Carry Flag Used by arithmetic instruction.															
AC	Auxiliary Carry Flag Used by instructions which execute BCD operations.															
F0	General Purpose Flag															
RS1 RS0	Register Bank select control bits These bits are used to select one of the four register banks.															
	<table border="1" style="width: 100%; border-collapse: collapse;"> <thead> <tr> <th style="text-align: center;">RS1</th> <th style="text-align: center;">RS0</th> <th style="text-align: left;">Function</th> </tr> </thead> <tbody> <tr> <td style="text-align: center;">0</td> <td style="text-align: center;">0</td> <td>Bank 0 selected, data address 00_H-07_H</td> </tr> <tr> <td style="text-align: center;">0</td> <td style="text-align: center;">1</td> <td>Bank 1 selected, data address 08_H-0F_H</td> </tr> <tr> <td style="text-align: center;">1</td> <td style="text-align: center;">0</td> <td>Bank 2 selected, data address 10_H-17_H</td> </tr> <tr> <td style="text-align: center;">1</td> <td style="text-align: center;">1</td> <td>Bank 3 selected, data address 18_H-1F_H</td> </tr> </tbody> </table>	RS1	RS0	Function	0	0	Bank 0 selected, data address 00 _H -07 _H	0	1	Bank 1 selected, data address 08 _H -0F _H	1	0	Bank 2 selected, data address 10 _H -17 _H	1	1	Bank 3 selected, data address 18 _H -1F _H
RS1	RS0	Function														
0	0	Bank 0 selected, data address 00 _H -07 _H														
0	1	Bank 1 selected, data address 08 _H -0F _H														
1	0	Bank 2 selected, data address 10 _H -17 _H														
1	1	Bank 3 selected, data address 18 _H -1F _H														
OV	Overflow Flag Used by arithmetic instruction.															
F1	General Purpose Flag															
P	Parity Flag Set/cleared by hardware after each instruction to indicate an odd/even number of "one" bits in the accumulator, i.e. even parity.															

Memory Organization

The C515C CPU manipulates data and operands in the following five address spaces:

- up to 64 Kbyte of internal/external program memory
- up to 64 Kbyte of external data memory
- 256 bytes of internal data memory
- 256 bytes CAN controller registers / data memory
- 2K bytes of internal XRAM data memory
- a 128 byte special function register area

Figure 5 illustrates the memory address spaces of the C515C.

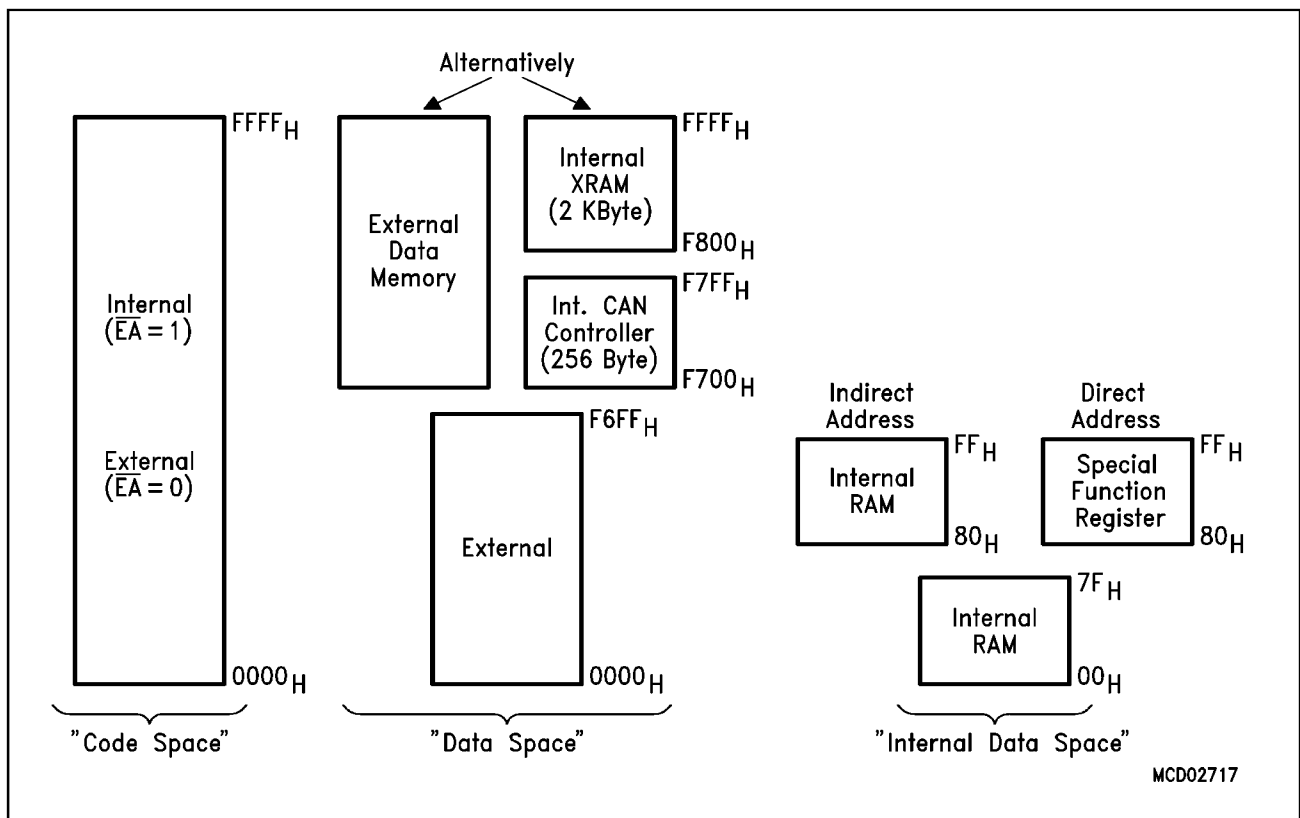

Figure 5
C515C Memory Map

Control of XRAM/CAN Controller Access

The XRAM in the C515C is a memory area that is logically located at the upper end of the external memory space, but is integrated on the chip. Because the XRAM and the CAN controller is used in the same way as external data memory the same instruction types (MOVX) must be used for accessing the XRAM. Two bits in SFR SYSCON, XMAP0 and XMAP1, control the accesses to the XRAM and the CAN controller.

Special Function Register SYSCON (Address B1_H)

Reset Value : X010XX01_B

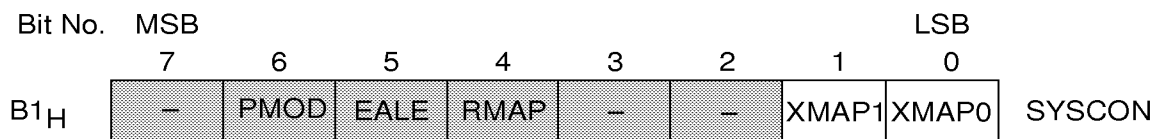

The function of the shaded bits is not described in this section.

Bit	Function
XMAP1	<p>XRAM/CAN controller visible access control</p> <p>Control bit for $\overline{RD}/\overline{WR}$ signals during XRAM/CAN Controller accesses. If addresses are outside the XRAM/CAN controller address range or if XRAM is disabled, this bit has no effect.</p> <p>XMAP1 = 0 : The signals \overline{RD} and \overline{WR} are not activated during accesses to the XRAM/CAN Controller</p> <p>XMAP1 = 1 : Ports 0, 2 and the signals \overline{RD} and \overline{WR} are activated during accesses to XRAM/CAN Controller. In this mode, address and data information during XRAM/CAN Controller accesses are visible externally.</p>
XMAP0	<p>Global XRAM/CAN controller access enable/disable control</p> <p>XMAP0 = 0 : The access to XRAM and CAN controller is enabled.</p> <p>XMAP0 = 1 : The access to XRAM and CAN controller is disabled (default after reset). All MOVX accesses are performed via the external bus. Further, this bit is hardware protected.</p>

Bit XMAP0 is hardware protected. If it is reset once (XRAM/CAN controller access enabled) it cannot be set by software. Only a reset operation will set the XMAP0 bit again.

The XRAM/CAN controller can be accessed by read/write instructions (MOVX A,DPTR, MOVX @DPTR,A), which use the 16-bit DPTR for indirect addressing. For accessing the XRAM or CAN controller, the effective address stored in DPTR must be in the range of F700_H to FFFF_H.

The XRAM can be also accessed by read/write instructions (MOVX A,@Ri, MOVX @Ri,A), which use only an 8-bit address (indirect addressing with registers R0 or R1). Therefore, a special page register XPAGE which provides the upper address information (A8-A15) during 8-bit XRAM accesses. The behaviour of Port 0 and P2 during a MOVX access depends on the control bits XMAP0 and XMAP1 in register SYSCON and on the state of pin \overline{EA} . **Table 2** lists the various operating conditions.

		$\overline{EA} = 0$			$\overline{EA} = 1$		
		XMAP1, XMAP0			XMAP1, XMAP0		
		00	10	X1	00	10	X1
MOVX @DPTR	DPTR < XRAM/CAN address range	a) P0/P2 → Bus b) $\overline{RD}/\overline{WR}$ active c) ext. memory is used	a) P0/P2 → Bus b) $\overline{RD}/\overline{WR}$ active c) ext. memory is used	a) P0/P2 → Bus b) $\overline{RD}/\overline{WR}$ active c) ext. memory is used	a) P0/P2 → Bus b) $\overline{RD}/\overline{WR}$ active c) ext. memory is used	a) P0/P2 → Bus b) $\overline{RD}/\overline{WR}$ active c) ext. memory is used	a) P0/P2 → Bus b) $\overline{RD}/\overline{WR}$ active c) ext. memory is used
	DPTR ≥ XRAM/CAN address range	a) P0/P2 → Bus (RD/WR-Data) b) $\overline{RD}/\overline{WR}$ inactive c) XRAM is used	a) P0/P2 → Bus (RD/WR-Data) b) $\overline{RD}/\overline{WR}$ active c) XRAM is used	a) P0/P2 → I/O b) $\overline{RD}/\overline{WR}$ active c) ext. memory is used	a) P0/P2 → I/O b) $\overline{RD}/\overline{WR}$ active c) XRAM is used	a) P0/P2 → Bus (RD/WR-Data) b) $\overline{RD}/\overline{WR}$ active c) XRAM is used	a) P0/P2 → Bus (RD/WR-Data) b) $\overline{RD}/\overline{WR}$ active c) XRAM is used
MOVX @ Ri	XPAGE < XRAM/CAN addr. page range	a) P0 → Bus P2 → I/O b) $\overline{RD}/\overline{WR}$ active c) ext. memory is used	a) P0 → Bus P2 → I/O b) $\overline{RD}/\overline{WR}$ active c) ext. memory is used	a) P0 → Bus P2 → I/O b) $\overline{RD}/\overline{WR}$ active c) ext. memory is used	a) P0 → Bus P2 → I/O b) $\overline{RD}/\overline{WR}$ active c) ext. memory is used	a) P0 → Bus P2 → I/O b) $\overline{RD}/\overline{WR}$ active c) ext. memory is used	a) P0 → Bus P2 → I/O b) $\overline{RD}/\overline{WR}$ active c) ext. memory is used
	XPAGE ≥ XRAM/CAN addr. page range	a) P0 → Bus (RD/WR-Data) P2 → I/O b) $\overline{RD}/\overline{WR}$ inactive c) XRAM is used	a) P0 → Bus (RD/WR-Data only) P2 → I/O b) $\overline{RD}/\overline{WR}$ active c) XRAM is used	a) P0 → Bus P2 → I/O b) $\overline{RD}/\overline{WR}$ active c) ext. memory is used	a) P2 → I/O P0/P2 → I/O b) $\overline{RD}/\overline{WR}$ inactive c) XRAM is used	a) P0 → Bus (RD/WR-Data) P2 → I/O b) $\overline{RD}/\overline{WR}$ active c) XRAM is used	a) P0 → Bus P2 → I/O b) $\overline{RD}/\overline{WR}$ active c) ext. memory is used

modes compatible to 8051/C501 family

Table 2
Behaviour of P0/P2 and $\overline{RD}/\overline{WR}$ During MOVX Accesses

Reset and System Clock

The reset input is an active low input at pin $\overline{\text{RESET}}$. Since the reset is synchronized internally, the $\overline{\text{RESET}}$ pin must be held low for at least two machine cycles (12 oscillator periods) while the oscillator is running. A pullup resistor is internally connected to V_{CC} to allow a power-up reset with an external capacitor only. An automatic reset can be obtained when V_{CC} is applied by connecting the $\overline{\text{RESET}}$ pin to V_{SS} via a capacitor. **Figure 6** shows the possible reset circuitries.

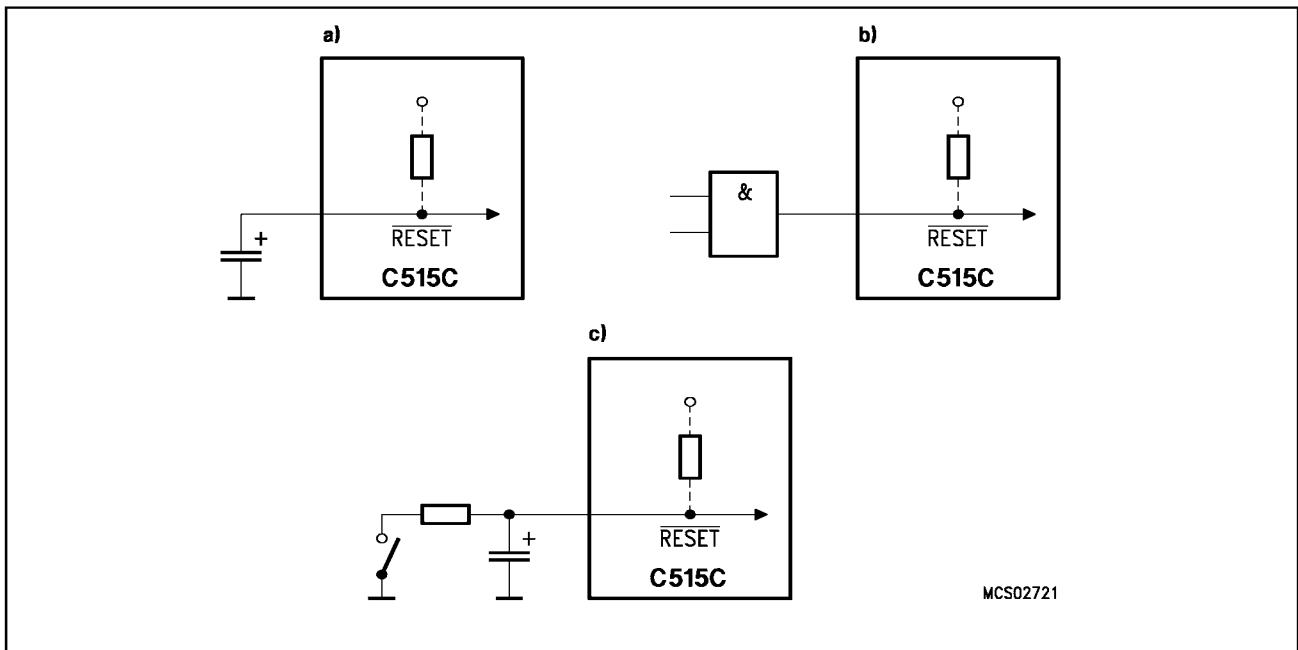

Figure 6
Reset Circuitries

Figure 7 shows the recommended oscillator circuitries for crystal and external clock operation.

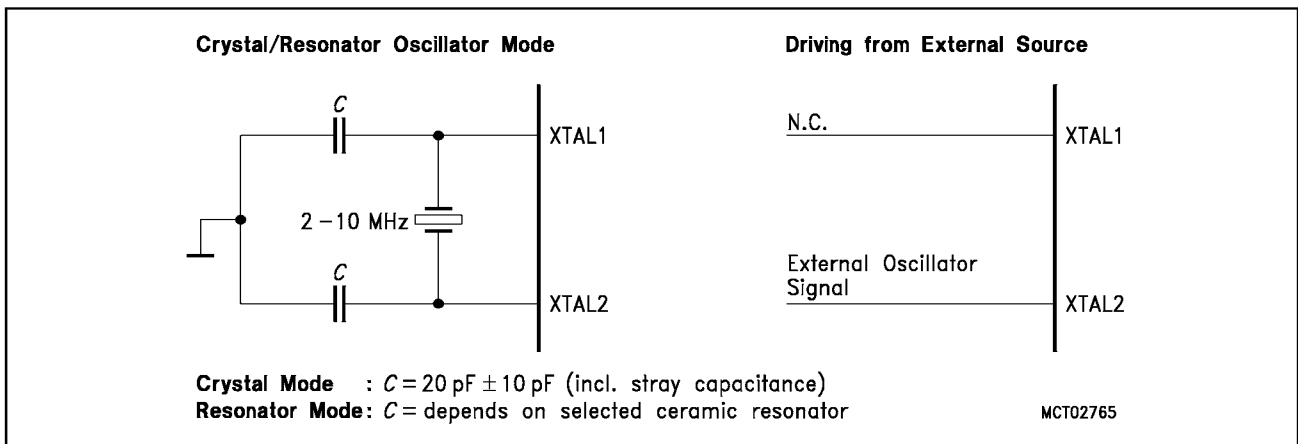

Figure 7
Recommended Oscillator Circuitries

Multiple Datapointers

As a functional enhancement to the standard 8051 architecture, the C515C contains eight 16-bit datapointers instead of only one datapointer. The instruction set uses just one of these datapointers at a time. The selection of the actual datapointer is done in the special function register DPSEL. **Figure 8** illustrates the datapointer addressing mechanism.

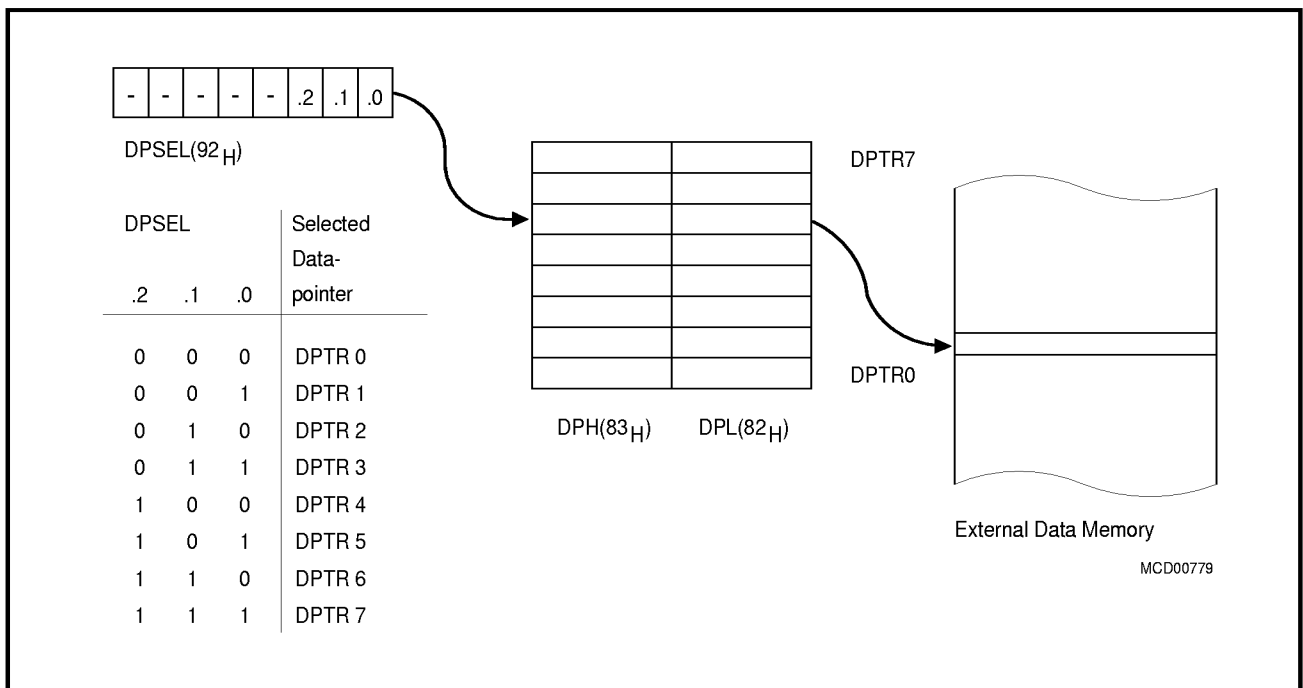

Figure 8
External Data Memory Addressing using Multiple Datapointers

Enhanced Hooks Emulation Concept

The Enhanced Hooks Emulation Concept of the C500 microcontroller family is a new, innovative way to control the execution of C500 MCUs and to gain extensive information on the internal operation of the controllers. Emulation of on-chip ROM based programs is possible, too.

Each production chip has built-in logic for the support of the Enhanced Hooks Emulation Concept. Therefore, no costly bond-out chips are necessary for emulation. This also ensures that emulation and production chips are identical.

The Enhanced Hooks Technology™, which requires embedded logic in the C500 allows the C500 together with an EH-IC to function similar to a bond-out chip. This simplifies the design and reduces costs of an ICE-system. ICE-systems using an EH-IC and a compatible C500 are able to emulate all operating modes of the different versions of the C500 microcontrollers. This includes emulation of ROM, ROM with code rollover and ROMless modes of operation. It is also able to operate in single step mode and to read the SFRs after a break.

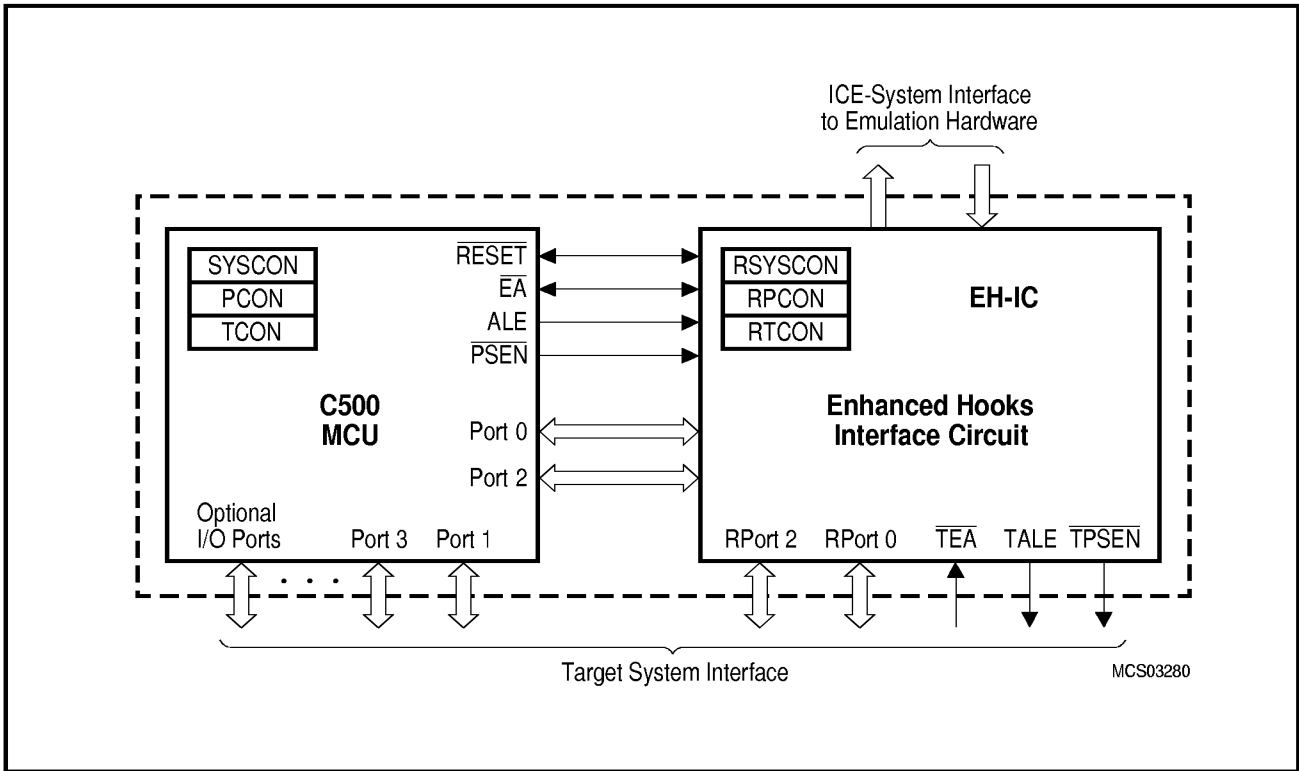

Figure 9
Basic C500 MCU Enhanced Hooks Concept Configuration

Port 0, port 2 and some of the control lines of the C500 based MCU are used by Enhanced Hooks Emulation Concept to control the operation of the device during emulation and to transfer informations about the programm execution and data transfer between the external emulation hardware (ICE-system) and the C500 MCU.

Special Function Registers

The registers, except the program counter and the four general purpose register banks, reside in the special function register area. The special function register area consists of two portions : the standard special function register area and the mapped special function register area. Two special function registers of the C515C (PCON1 and DIR5) are located in the mapped special function register area. For accessing the mapped special function register area, bit RMAP in special function register SYSCON must be set. All other special function registers are located in the standard special function register area which is accessed when RMAP is cleared ("0"). As long as bit RMAP is set, mapped special function register area can be accessed. This bit is not cleared by hardware automatically. Thus, when non-mapped/mapped registers are to be accessed, the bit RMAP must be cleared/set by software, respectively each.

Special Function Register SYSCON (Address B1_H)

Reset Value : 1010XX01_B

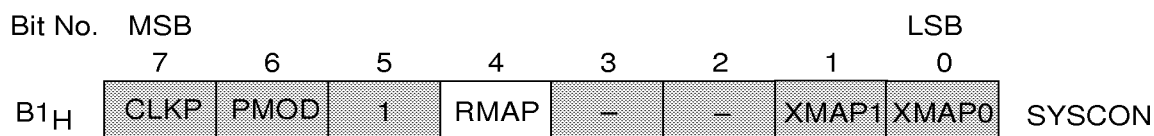

Bit	Function
RMAP	Special function register map bit RMAP = 0 : The access to the non-mapped (standard) special function register area is enabled (reset value). RMAP = 1 : The access to the mapped special function register area is enabled.

The 59 special function registers (SFRs) in the standard and mapped SFR area include pointers and registers that provide an interface between the CPU and the other on-chip peripherals. The SFRs of the C515C are listed in **table 3** and **table 4**. In **table 3** they are organized in groups which refer to the functional blocks of the C515C. The CAN-SFRs are also included in **table 3**. **Table 4** illustrates the contents of the SFRs in numeric order of their addresses. **Table 5** list the CAN-SFRs in numeric order of their addresses.

Table 3
Special Function Registers - Functional Blocks

Block	Symbol	Name	Address	Contents after Reset
CPU	ACC	Accumulator	E0H ¹⁾	00H
	B	B-Register	F0H ¹⁾	00H
	DPH	Data Pointer, High Byte	83H	00H
	DPL	Data Pointer, Low Byte	82H	00H
	DPSEL	Data Pointer Select Register	92H	XXXXX000B ³⁾
	PSW	Program Status Word Register	D0H ¹⁾	00H
	SP	Stack Pointer	81H	07H
	SYSCON ²⁾	System Control Register	B1H	X010XX01B ³⁾
A/D- Converter	ADCON0 ²⁾	A/D Converter Control Register 0	D8H ¹⁾	00H
	ADCON1	A/D Converter Control Register 1	DC _H	0XXXX000B ³⁾
	ADDATH	A/D Converter Data Register High Byte	D9 _H	00H
	ADDATL	A/D Converter Data Register Low Byte	DA _H ⁴⁾	00XXXXXXB ³⁾
Interrupt System	IEN0 ²⁾	Interrupt Enable Register 0	A8H ¹⁾	00H
	IEN1 ²⁾	Interrupt Enable Register 1	B8H ¹⁾	00H
	IEN2	Interrupt Enable Register 2	9A _H	XX00X00XB ³⁾
	IP0 ²⁾	Interrupt Priority Register 0	A9 _H	00H
	IP1	Interrupt Priority Register 1	B9 _H	0X000000B ³⁾
	TCON ²⁾	Timer Control Register	88H ¹⁾	00H
	T2CON ²⁾	Timer 2 Control Register	C8H ¹⁾	00H
	SCON ²⁾	Serial Channel Control Register	98H ¹⁾	00H
IRCON	Interrupt Request Control Register	C0H ¹⁾	00H	
XRAM	XPAGE	Page Address Register for Extended on-chip XRAM and CAN Controller	91 _H	00H
	SYSCON ²⁾	System Control Register	B1 _H	X010XX01B ³⁾
Ports	P0	Port 0	80H ¹⁾	FFH
	P1	Port 1	90H ¹⁾	FFH
	P2	Port 2	A0H ¹⁾	FFH
	P3	Port 3	B0H ¹⁾	FFH
	P4	Port 4	E8H ¹⁾	FFH
	P5	Port 5	F8H ¹⁾	FFH
	DIR5	Port 5 Direction Register	F8H ¹⁾⁴⁾	FFH
	P6	Port 6, Analog/Digital Input	DB _H	–
	P7	Port 7	FA _H	XXXXXXXX1B ³⁾
	SYSCON ²⁾	System Control Register	B1 _H	X010XX01B ³⁾

1) Bit-addressable special function registers

2) This special function register is listed repeatedly since some bits of it also belong to other functional blocks.

3) "X" means that the value is undefined and the location is reserved

4) This SFR is a mapped SFR. For accessing this SFR, bit PDIR in SFR IP1 must be set.

Table 3
Special Function Registers - Functional Blocks (cont'd)

Block	Symbol	Name	Address	Contents after Reset	
Serial Channel	ADCON0 ²⁾	A/D Converter Control Register 0	D8H ¹⁾	00H	
	PCON ²⁾	Power Control Register	87H	00H	
	SBUF	Serial Channel Buffer Register	99H	XXH ³⁾	
	SCON	Serial Channel Control Register	98H ¹⁾	00H	
	SRELL	Serial Channel Reload Register, low byte	AAH	D9H	
	SRELH	Serial Channel Reload Register, high byte	BAH	XXXXXX11B ³⁾	
CAN Controller	CR	Control Register	F700H	01H	
	SR	Status Register	F701H	XXH ³⁾	
	IR	Interrupt Register	F702H	XXH ³⁾	
	BTR0	Bit Timing Register Low	F704H	UUH ³⁾	
	BTR1	Bit Timing Register High	F705H	0UUUUUUUB ³⁾	
	GMS0	Global Mask Short Register Low	F706H	UUH ³⁾	
	GMS1	Global Mask Short Register High	F707H	UUU11111B ³⁾	
	UGML0	Upper Global Mask Long Register Low	F708H	UUH ³⁾	
	UGML1	Upper Global Mask Long Register High	F709H	UUH ³⁾	
	LGML0	Lower Global Mask Long Register Low	F70AH	UUH ³⁾	
	LGML1	Lower Global Mask Long Register High	F70BH	UUUUU000B ³⁾	
	UMLM0	Upper Mask of Last Message Register Low	F70CH	UUH ³⁾	
	UMLM1	Upper Mask of Last Message Register High	F70DH	UUH ³⁾	
	LMLM0	Lower Mask of Last Message Register Low	F70EH	UUH ³⁾	
	LMLM1	Lower Mask of Last Message Register High	F70FH	UUUUU000B ³⁾	
			Message Object Registers :		
	MCR0	Message Control Register Low	F7n0H ⁵⁾	UUH ³⁾	
	MCR1	Message Control Register High	F7n1H ⁵⁾	UUH ³⁾	
	UAR0	Upper Arbitration Register Low	F7n2H ⁵⁾	UUH ³⁾	
	UAR1	Upper Arbitration Register High	F7n3H ⁵⁾	UUH ³⁾	
	LAR0	Lower Arbitration Register Low	F7n4H ⁵⁾	UUH ³⁾	
	LAR1	Lower Arbitration Register High	F7n5H ⁵⁾	UUUUU000B ³⁾	
	MCFG	Message Configuration Register	F7n6H ⁵⁾	UUUUUU00B ³⁾	
	DB0	Message Data Byte 0	F7n7H ⁵⁾	XXH ³⁾	
	DB1	Message Data Byte 1	F7n8H ⁵⁾	XXH ³⁾	
	DB2	Message Data Byte 2	F7n9H ⁵⁾	XXH ³⁾	
	DB3	Message Data Byte 3	F7nAH ⁵⁾	XXH ³⁾	
	DB4	Message Data Byte 4	F7nBH ⁵⁾	XXH ³⁾	
	DB5	Message Data Byte 5	F7nC_H ⁵⁾	XXH ³⁾	
	DB6	Message Data Byte 6	F7nDH ⁵⁾	XXH ³⁾	
DB7	Message Data Byte 7	F7nEH ⁵⁾	XXH ³⁾		

1) Bit-addressable special function registers

2) This special function register is listed repeatedly since some bits of it also belong to other functional blocks.

3) "X" means that the value is undefined and the location is reserved. "U" means that the value is unchanged by a reset operation. "U" values are undefined (as "X") after a power-on reset operation

4) SFR is located in the mapped SFR area. For accessing this SFR, bit RMAP in SFR SYSCON must be set.

5) The notation "n" in the message object address definition defines the number of the related message object.

Table 3
Special Function Registers - Functional Blocks (cont'd)

Block	Symbol	Name	Address	Contents after Reset
SSC Interface	SSCCON	SSC Control Register	93H ¹⁾	07H
	STB	SSC Transmit Buffer	94H	XXH ³⁾
	SRB	SSC Receive Register	95H	XXH ³⁾
	SCF	SSC Flag Register	ABH ¹⁾	XXXXXX00B ³⁾
	SCIEN	SSC Interrupt Enable Register	ACH	XXXXXX00B ³⁾
	SSCMOD	SSC Mode Test Register	96H	00H
Timer 0/ Timer 1	TCON	Timer 0/1 Control Register	88H ¹⁾	00H
	TH0	Timer 0, High Byte	8CH	00H
	TH1	Timer 1, High Byte	8DH	00H
	TL0	Timer 0, Low Byte	8AH	00H
	TL1	Timer 1, Low Byte	8BH	00H
	TMOD	Timer Mode Register	89H	00H
Compare/ Capture Unit / Timer 2	CCEN	Comp./Capture Enable Reg.	C1H	00H
	CCH1	Comp./Capture Reg. 1, High Byte	C3H	00H
	CCH2	Comp./Capture Reg. 2, High Byte	C5H	00H
	CCH3	Comp./Capture Reg. 3, High Byte	C7H	00H
	CCL1	Comp./Capture Reg. 1, Low Byte	C2H	00H
	CCL2	Comp./Capture Reg. 2, Low Byte	C4H	00H
	CCL3	Comp./Capture Reg. 3, Low Byte	C6H	00H
	CRCH	Com./Rel./Capt. Reg. High Byte	CBH	00H
	CRCL	Com./Rel./Capt. Reg. Low Byte	CAH	00H
	TH2	Timer 2, High Byte	CDH	00H
	TL2	Timer 2, Low Byte	CCH	00H
	T2CON	Timer 2 Control Register	C8H ¹⁾	00H
	Watchdog	WDTREL	Watchdog Timer Reload Register	86H
IEN0 ²⁾		Interrupt Enable Register 0	A8H ¹⁾	00H
IEN1 ²⁾		Interrupt Enable Register 1	B8H ¹⁾	00H
IPO ²⁾		Interrupt Priority Register 0	A9H	00H
Power Save Modes	PCON ²⁾	Power Control Register	87H	00H
	PCON1	Power Control Register 1	88H ⁴⁾	0XXXXXXXXB ³⁾

1) Bit-addressable special function registers

2) This special function register is listed repeatedly since some bits of it also belong to other functional blocks.

3) "X" means that the value is undefined and the location is reserved

4) SFR is located in the mapped SFR area. For accessing this SFR, bit RMAP in SFR SYSCON must be set.

Table 4
Contents of the SFRs, SFRs in numeric order of their addresses

Addr	Register	Content after Reset ¹⁾	Bit 7	Bit 6	Bit 5	Bit 4	Bit 3	Bit 2	Bit 1	Bit 0
80 _H ²⁾	P0	FF _H	.7	.6	.5	.4	.3	.2	.1	.0
81 _H	SP	07 _H	.7	.6	.5	.4	.3	.2	.1	.0
82 _H	DPL	00 _H	.7	.6	.5	.4	.3	.2	.1	.0
83 _H	DPH	00 _H	.7	.6	.5	.4	.3	.2	.1	.0
86 _H	WDTREL	00 _H	WDT PSEL	.6	.5	.4	.3	.2	.1	.0
87 _H	PCON	00 _H	SMOD	PDS	IDLS	SD	GF1	GF0	PDE	IDLE
88 _H ²⁾	TCON	00 _H	TF1	TR1	TF0	TR0	IE1	IT1	IE0	IT0
88 _H ³⁾	PCON1	0XXX-XXXX _B	EWPD	–	–	–	–	–	–	–
89 _H	TMOD	00 _H	GATE	C/T	M1	M0	GATE	C/T	M1	M0
8A _H	TL0	00 _H	.7	.6	.5	.4	.3	.2	.1	.0
8B _H	TL1	00 _H	.7	.6	.5	.4	.3	.2	.1	.0
8C _H	TH0	00 _H	.7	.6	.5	.4	.3	.2	.1	.0
8D _H	TH1	00 _H	.7	.6	.5	.4	.3	.2	.1	.0
90 _H ²⁾	P1	FF _H	T2	CLK-OUT	T2EX	INT2	INT6	INT5	INT4	INT3
91 _H	XPAGE	00 _H	.7	.6	.5	.4	.3	.2	.1	.0
92 _H	DPSEL	XXXX-X000 _B	–	–	–	–	–	.2	.1	.0
93 _H	SSCCON	07 _H	SCEN	TEN	MSTR	CPOL	CPHA	BRS2	BRS1	BRS0
94 _H	STB	XX _H	.7	.6	.5	.4	.3	.2	.1	.0
95 _H	SRB	XX _H	.7	.6	.5	.4	.3	.2	.1	.0
96 _H	SSCMOD	00 _H	LOOPB	TRIO	0	0	0	0	0	LSBSM
98 _H ²⁾	SCON	00 _H	SM0	SM1	SM2	REN	TB8	RB8	TI	RI
99 _H	SBUF	XX _H	.7	.6	.5	.4	.3	.2	.1	.0
9A _H	IEN2	X00X-X00X _B	–	–	EX8	EX7	–	ESSC	ECAN	–
A0 _H ²⁾	P2	FF _H	.7	.6	.5	.4	.3	.2	.1	.0
A8 _H ²⁾	IEN0	00 _H	EA	WDT	ET2	ES	ET1	EX1	ET0	EX0

1) X means that the value is undefined and the location is reserved

2) Bit-addressable special function registers

3) SFR is located in the mapped SFR area. For accessing this SFR, bit RMAP in SFR SYSCON must be set.

Table 4
Contents of the SFRs, SFRs in numeric order of their addresses (cont'd)

Addr	Register	Content after Reset ¹⁾	Bit 7	Bit 6	Bit 5	Bit 4	Bit 3	Bit 2	Bit 1	Bit 0
A9 _H	IP0	00 _H	OWDS	WDTS	.5	.4	.3	.2	.1	.0
AA _H	SRELL	D9 _H	.7	.6	.5	.4	.3	.2	.1	.0
AB _H	SCF	XXXX-XX00 _B	–	–	–	–	–	–	WCOL	TC
AC _H	SCIEN	XXXX-XX00 _B	–	–	–	–	–	–	WCEN	TCEN
B0 _H ²⁾	P3	FF _H	RD	WR	T1	T0	INT1	INT0	TxD	RxD
B1 _H	SYSCON	X010-XX01 _B	–	PMOD	EALE	RMAP	–	–	XMAP1	XMAP0
B8 _H ²⁾	IEN1	00 _H	EXEN2	SWDT	EX6	EX5	EX4	EX3	EX2	EADC
B9 _H	IP1	0X00-0000 _B	PDIR	–	.5	.4	.3	.2	.1	.0
BA _H	SRELH	XXXX-XX11 _B	–	–	–	–	–	–	.1	.0
C0 _H ²⁾	IRCON	00 _H	EXF2	TF2	IEX6	IEX5	IEX4	IEX3	IEX2	IADC
C1 _H	CCEN	00 _H	COCA H3	COCAL 3	COCA H2	COCAL 2	COCA H1	COCAL 1	COCA H0	COCAL 0
C2 _H	CCL1	00 _H	.7	.6	.5	.4	.3	.2	.1	.0
C3 _H	CCH1	00 _H	.7	.6	.5	.4	.3	.2	.1	.0
C4 _H	CCL2	00 _H	.7	.6	.5	.4	.3	.2	.1	.0
C5 _H	CCH2	00 _H	.7	.6	.5	.4	.3	.2	.1	.0
C6 _H	CCL3	00 _H	.7	.6	.5	.4	.3	.2	.1	.0
C7 _H	CCH3	00 _H	.7	.6	.5	.4	.3	.2	.1	.0
C8 _H ²⁾	T2CON	00 _H	T2PS	I3FR	I2FR	T2R1	T2R0	T2CM	T2I1	T2I0
CA _H	CRCL	00 _H	.7	.6	.5	.4	.3	.2	.1	.0
CB _H	CRCH	00 _H	.7	.6	.5	.4	.3	.2	.1	.0
CC _H	TL2	00 _H	.7	.6	.5	.4	.3	.2	.1	.0
CD _H	TH2	00 _H	.7	.6	.5	.4	.3	.2	.1	.0

1) X means that the value is undefined and the location is reserved

2) Bit-addressable special function registers

Table 4
Contents of the SFRs, SFRs in numeric order of their addresses (cont'd)

Addr	Register	Content after Reset ¹⁾	Bit 7	Bit 6	Bit 5	Bit 4	Bit 3	Bit 2	Bit 1	Bit 0
D0 _H ²⁾	PSW	00 _H	CY	AC	F0	RS1	RS0	OV	F1	P
D8 _H ²⁾	ADCON0	00 _H	BD	CLK	ADEX	BSY	ADM	MX2	MX1	MX0
D9 _H	ADDATH	00 _H	.9	.8	.7	.6	.5	.4	.3	.2
DA _H	ADDATL	00XX- XXXX _B	.1	.0	–	–	–	–	–	–
DB _H	P6	–	.7	.6	.5	.4	.3	.2	.1	.0
DC _H	ADCON1	0XXX- X000 _B	ADCL	–	–	–	0	MX2	MX1	MX0
E0 _H ²⁾	ACC	00 _H	.7	.6	.5	.4	.3	.2	.1	.0
E8 _H ²⁾	P4	00 _H	RXDC	TXDC	INT8	SLS	STO	SRI	SCLK	ADST
F0 _H ²⁾	B	00 _H	.7	.6	.5	.4	.3	.2	.1	.0
F8 _H ²⁾	P5	FF _H	.7	.6	.5	.4	.3	.2	.1	.0
F8 _H ²⁾	DIR5 ³⁾	FF _H	.7	.6	.5	.4	.3	.2	.1	.0
FA _H	P7	XXXX- XXX1 _B	–	–	–	–	–	–	–	.0

1) X means that the value is undefined and the location is reserved

2) Bit-addressable special function registers

3) This SFR is a mapped SFR. For accessing this SFR, bit PDIR in SFR IP1 must be set.

Table 5
Contents of the CAN Registers in numeric order of their addresses

Addr. n=1-F _H 1)	Register	Content after Reset 2)	Bit 7	Bit 6	Bit 5	Bit 4	Bit 3	Bit 2	Bit 1	Bit 0
F700 _H	CR	01 _H	TEST	CCE	0	0	EIE	SIE	IE	INIT
F701 _H	SR	XX _H	BOFF	EWRN	–	RXOK	TXOK	LEC2	LEC1	LEC0
F702 _H	IR	XX _H	INTID							
F704 _H	BTR0	UU _H	SJW			BRP				
F705 _H	BTR1	0UUU. UUUU _B	0	TSEG2			TSEG1			
F706 _H	GMS0	UU _H	ID28-21							
F707 _H	GMS1	UUU1. 1111 _B	ID20-18			1	1	1	1	1
F708 _H	UGML0	UU _H	ID28-21							
F709 _H	UGML1	UU _H	ID20-13							
F70A _H	LGML0	UU _H	ID12-5							
F70B _H	LGML1	UUUU. U000 _B	ID4-0					0	0	0
F70C _H	UMLM0	UU _H	ID28-21							
F70D _H	UMLM1	UU _H	ID20-18			ID17-13				
F70E _H	LMLM0	UU _H	ID12-5							
F70F _H	LMLM1	UUUU. U000 _B	ID4-0					0	0	0
F7n0 _H	MCR0	UU _H	MSGVAL		TXIE		RXIE		INTPND	
F7n1 _H	MCR1	UU _H	RMT PND		TXRQ		MSGLST CPUUPD		NEWDAT	
F7n2 _H	UAR0	UU _H	ID28-21							
F7n3 _H	UAR1	UU _H	ID20-18			ID17-13				
F7n4 _H	LAR0	UU _H	ID12-5							
F7n5 _H	LAR1	UUUU. U000 _B	ID4-0					0	0	0
F7n6 _H	MCFG	UUUU. UU00 _B	DLC			DIR	XTD	0	0	

1) The notation "n" in the address definition defines the number of the related message object.

2) "X" means that the value is undefined and the location is reserved. "U" means that the value is unchanged by a reset operation. "U" values are undefined (as "X") after a power-on reset operation

Table 5
Contents of the CAN Registers in numeric order of their addresses (cont'd)

Addr. n=1-F _H 1)	Register	Content after Reset 2)	Bit 7	Bit 6	Bit 5	Bit 4	Bit 3	Bit 2	Bit 1	Bit 0
F7n7 _H	DB0	XX _H	.7	.6	.5	.4	.3	.2	.1	.0
F7n8 _H	DB1	XX _H	.7	.6	.5	.4	.3	.2	.1	.0
F7n9 _H	DB2	XX _H	.7	.6	.5	.4	.3	.2	.1	.0
F7nA _H	DB3	XX _H	.7	.6	.5	.4	.3	.2	.1	.0
F7nB _H	DB4	XX _H	.7	.6	.5	.4	.3	.2	.1	.0
F7nC _H	DB5	XX _H	.7	.6	.5	.4	.3	.2	.1	.0
F7nD _H	DB6	XX _H	.7	.6	.5	.4	.3	.2	.1	.0
F7nE _H	DB7	XX _H	.7	.6	.5	.4	.3	.2	.1	.0

- 1) The notation "n" in the address definition defines the number of the related message object.
- 2) "X" means that the value is undefined and the location is reserved. "U" means that the value is unchanged by a reset operation. "U" values are undefined (as "X") after a power-on reset operation

Digital I/O Ports

The C515C allows for digital I/O on 49 lines grouped into 6 bidirectional 8-bit ports and one 1-bit port. Each port bit consists of a latch, an output driver and an input buffer. Read and write accesses to the I/O ports P0 through P7 are performed via their corresponding special function registers P0 to P7. The port structure of port 5 of the C515C is especially designed to operate either as a quasi-bidirectional port structure, compatible to the standard 8051-Family, or as a genuine bidirectional port structure. This port operating mode can be selected by software (setting or clearing the bit PMOD in the SFR SYSCON).

The output drivers of port 0 and 2 and the input buffers of port 0 are also used for accessing external memory. In this application, port 0 outputs the low byte of the external memory address, time-multiplexed with the byte being written or read. Port 2 outputs the high byte of the external memory address when the address is 16 bits wide. Otherwise, the port 2 pins continue emitting the P2 SFR contents.

Analog Input Ports

Port 6 is available as input port only and provides two functions. When used as digital inputs, the corresponding SFR P6 contains the digital value applied to the port 6 lines. When used for analog inputs the desired analog channel is selected by a three-bit field in SFR ADCON0 or SFR ADCON1. Of course, it makes no sense to output a value to these input-only ports by writing to the SFR P6. This will have no effect.

If a digital value is to be read, the voltage levels are to be held within the input voltage specifications (V_{IL}/V_{IH}). Since P6 is not bit-addressable, all input lines of P6 are read at the same time by byte instructions.

Nevertheless, it is possible to use port 6 simultaneously for analog and digital input. However, care must be taken that all bits of P6 that have an undetermined value caused by their analog function are masked.

Port Structure Selection of Port 5

After a reset operation of the C515C, the quasi-bidirectional 8051-compatible port structure is selected. For selection of the bidirectional (CMOS) port 5 structure the bit PMOD of SFR SYSCON must be set. Because each port 5 pin can be programmed as an input or an output, additionally, after the selection of the bidirectional mode the direction register DIR5 of port 5 must be written. This direction register is mapped to the port 5 register. This means, the port register address is equal to its direction register address. **Figure 10** illustrates the port- and direction register configuration.

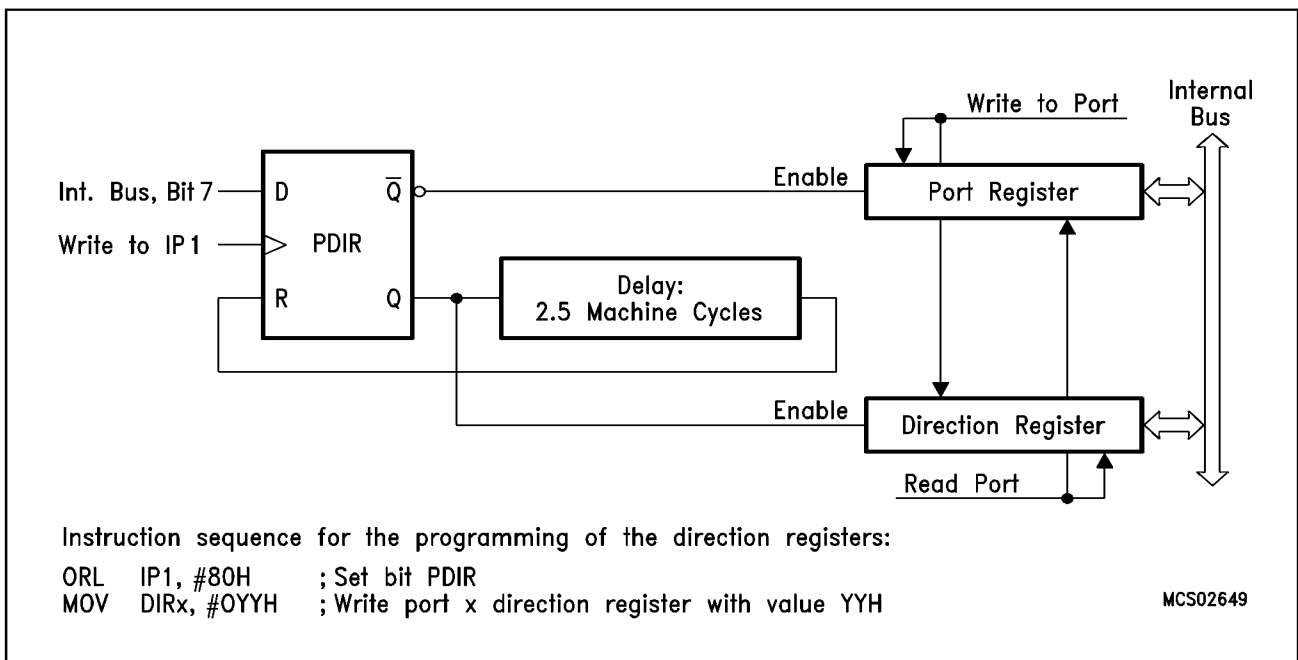

Figure 10
Port Register, Direction Register

Timer / Counter 0 and 1

Timer/Counter 0 and 1 can be used in four operating modes as listed in **table 6** :

Table 6
Timer/Counter 0 and 1 Operating Modes

Mode	Description	TMOD		Timer/Counter Input Clock	
		M1	M0	internal	external (max)
0	8-bit timer/counter with a divide-by-32 prescaler	0	0	$f_{osc}/6 \times 32$	$f_{osc}/12 \times 32$
1	16-bit timer/counter	0	1	$f_{osc}/6$	$f_{osc}/12$
2	8-bit timer/counter with 8-bit autoreload	1	0		
3	Timer/counter 0 used as one 8-bit timer/counter and one 8-bit timer / Timer 1 stops	1	1		

In the “timer” function ($C/\bar{T} = '0'$) the register is incremented every machine cycle. Therefore the count rate is $f_{osc}/6$.

In the “counter” function the register is incremented in response to a 1-to-0 transition at its corresponding external input pin (P3.4/T0, P3.5/T1). Since it takes two machine cycles to detect a falling edge the max. count rate is $f_{osc}/12$. External inputs $\overline{INT0}$ and $\overline{INT1}$ (P3.2, P3.3) can be programmed to function as a gate to facilitate pulse width measurements. **Figure 11** illustrates the input clock logic

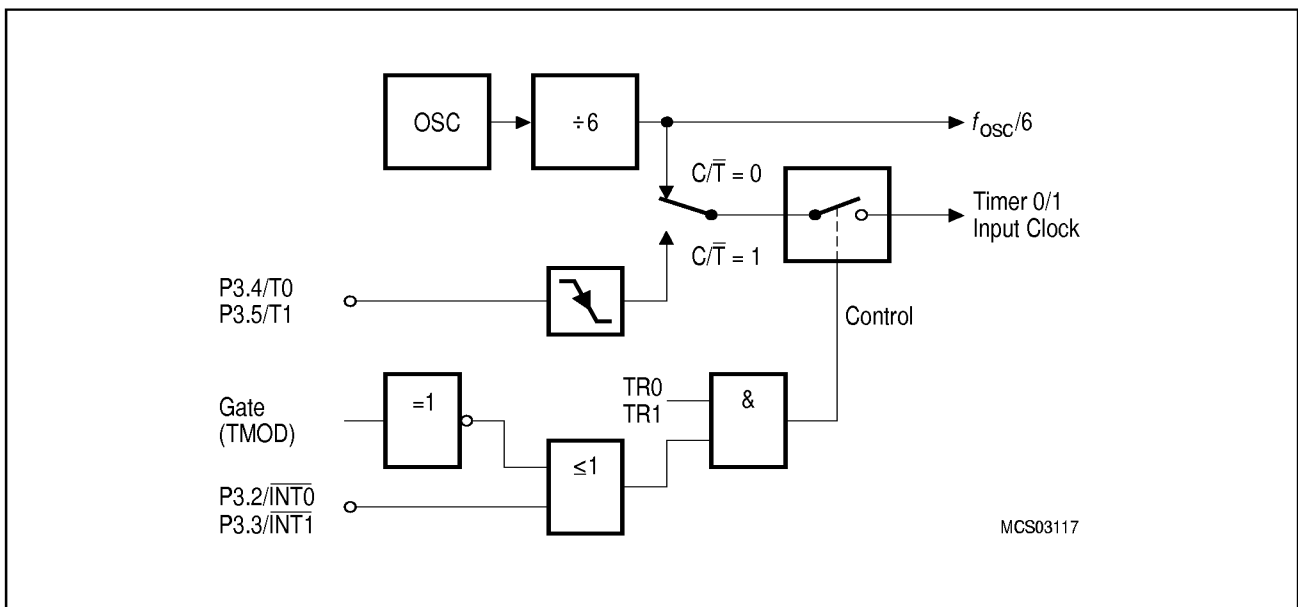

Figure 11
Timer/Counter 0 and 1 Input Clock Logic

Timer/Counter 2 with Compare/Capture/Reload

The timer 2 of the C515C provides additional compare/capture/reload features, which allow the selection of the following operating modes:

- Compare : up to 4 PWM signals with 16-bit/600 ns resolution
- Capture : up to 4 high speed capture inputs with 600 ns resolution
- Reload : modulation of timer 2 cycle time

The block diagram in **figure 12** shows the general configuration of timer 2 with the additional compare/capture/reload registers. The I/O pins which can be used for timer 2 control are located as multifunctional port functions at port 1.

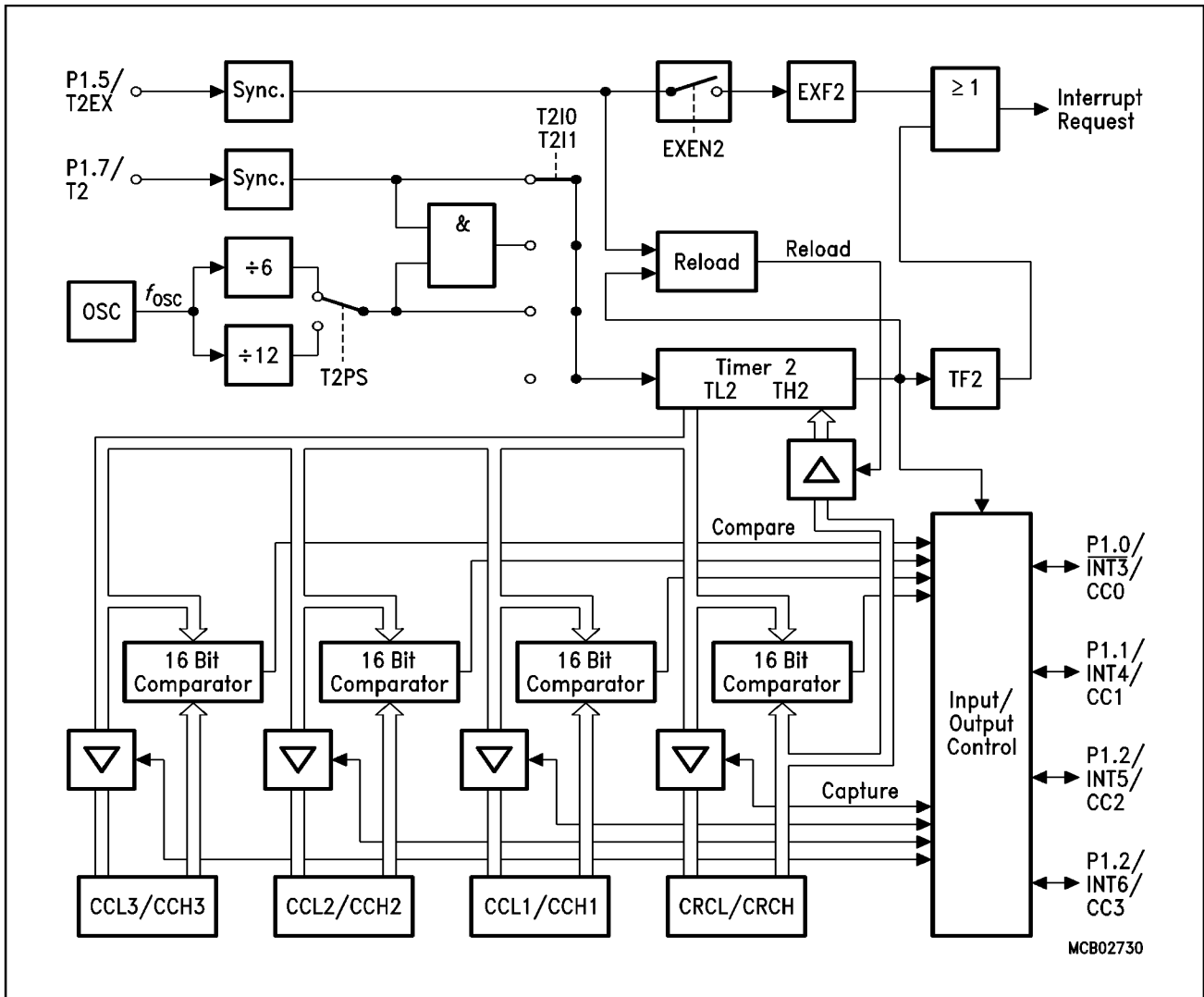

Figure 12
Timer 2 Block Diagram

Timer 2 Operating Modes

The timer 2, which is a 16-bit-wide register, can operate as timer, event counter, or gated timer. A roll-over of the count value in TL2/TH2 from all 1's to all 0's sets the timer overflow flag TF2 in SFR IRCON, which can generate an interrupt. The bits in register T2CON are used to control the timer 2 operation.

Timer Mode : In timer function, the count rate is derived from the oscillator frequency. A prescaler offers the possibility of selecting a count rate of 1/6 or 1/12 of the oscillator frequency.

Gated Timer Mode : In gated timer function, the external input pin T2 (P1.7) functions as a gate to the input of timer 2. If T2 is high, the internal clock input is gated to the timer. T2 = 0 stops the counting procedure. This facilitates pulse width measurements. The external gate signal is sampled once every machine cycle.

Event Counter Mode : In the event counter function, the timer 2 is incremented in response to a 1-to-0 transition at its corresponding external input pin T2 (P1.7). In this function, the external input is sampled every machine cycle. Since it takes two machine cycles (12 oscillator periods) to recognize a 1-to-0 transition, the maximum count rate is 1/6 of the oscillator frequency. There are no restrictions on the duty cycle of the external input signal, but to ensure that a given level is sampled at least once before it changes, it must be held for at least one full machine cycle.

Reload of Timer 2 : Two reload modes are selectable:

In mode 0, when timer 2 rolls over from all 1's to all 0's, it not only sets TF2 but also causes the timer 2 registers to be loaded with the 16-bit value in the CRC register, which is preset by software.

In mode 1, a 16-bit reload from the CRC register is caused by a negative transition at the corresponding input pin P1.5/T2EX. This transition will also set flag EXF2 if bit EXEN2 in SFR IEN1 has been set.

Timer 2 Compare Modes

The compare function of a timer/register combination operates as follows : the 16-bit value stored in a compare or compare/capture register is compared with the contents of the timer register; if the count value in the timer register matches the stored value, an appropriate output signal is generated at a corresponding port pin and an interrupt can be generated.

Compare Mode 0

In compare mode 0, upon matching the timer and compare register contents, the output signal changes from low to high. It goes back to a low level on timer overflow. As long as compare mode 0 is enabled, the appropriate output pin is controlled by the timer circuit only and writing to the port will have no effect. **Figure 13** shows a functional diagram of a port circuit when used in compare mode 0. The port latch is directly controlled by the timer overflow and compare match signals. The input line from the internal bus and the write-to-latch line of the port latch are disconnected when compare mode 0 is enabled.

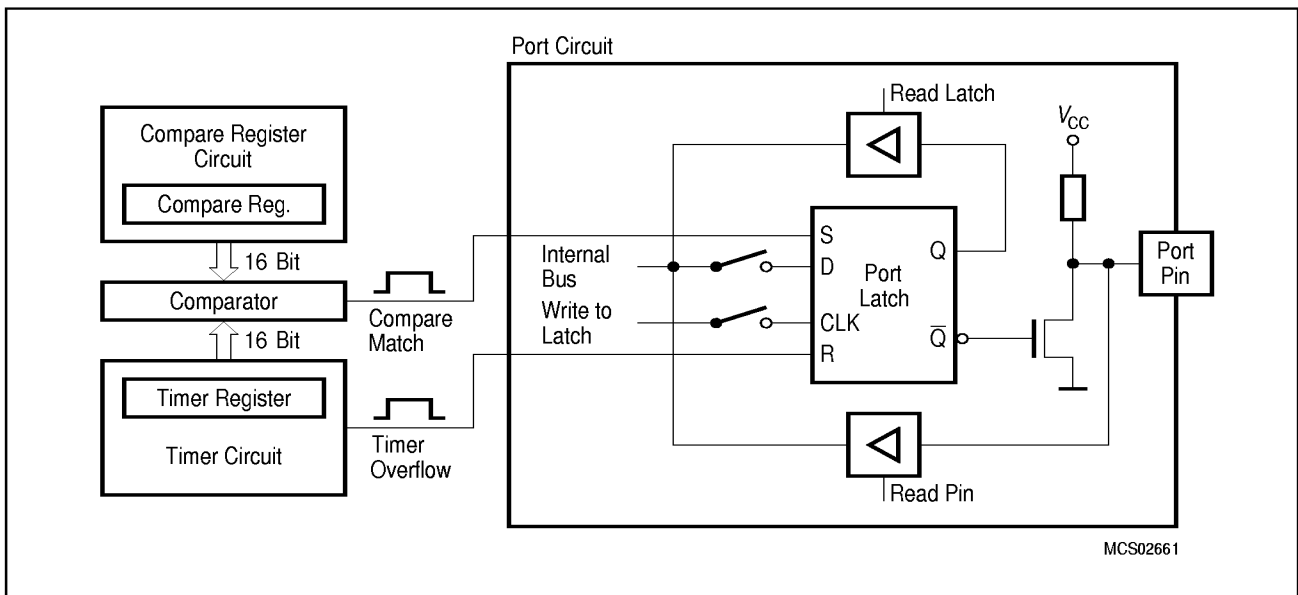

Figure 13
Port Latch in Compare Mode 0

Compare Mode 1

If compare mode 1 is enabled and the software writes to the appropriate output latch at the port, the new value will not appear at the output pin until the next compare match occurs. Thus, it can be chosen whether the output signal has to make a new transition (1-to-0 or 0-to-1, depending on the actual pin-level) or should keep its old value at the time when the timer value matches the stored compare value.

In compare mode 1 (see **figure 14**) the port circuit consists of two separate latches. One latch (which acts as a "shadow latch") can be written under software control, but its value will only be transferred to the port latch (and thus to the port pin) when a compare match occurs.

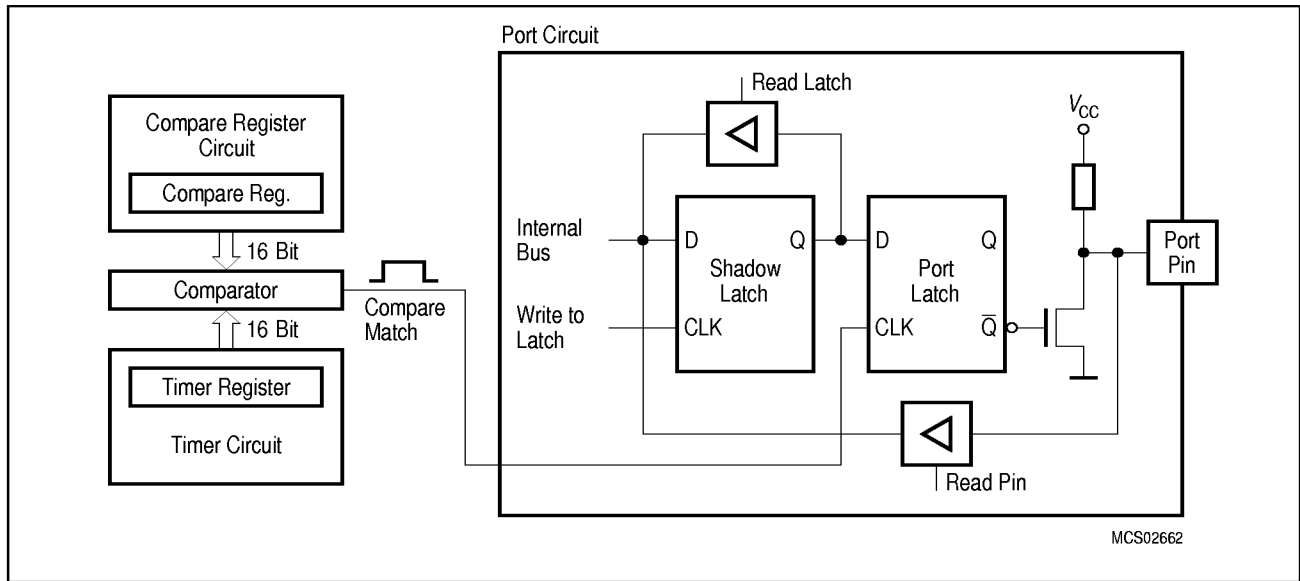

Figure 14
Compare Function in Compare Mode 1

Serial Interface (USART)

The serial port is full duplex and can operate in four modes (one synchronous mode, three asynchronous modes) as illustrated in **table 7**.

Table 7
USART Operating Modes

Mode	SCON		Description
	SM0	SM1	
0	0	0	Shift register mode, fixed baud rate Serial data enters and exits through RxD; TxD outputs the shift clock; 8-bit are transmitted/received (LSB first)
1	0	1	8-bit UART, variable baud rate 10 bits are transmitted (through TxD) or received (at RxD)
2	1	0	9-bit UART, fixed baud rate 11 bits are transmitted (through TxD) or received (at RxD)
3	1	1	9-bit UART, variable baud rate Like mode 2

For clarification some terms regarding the difference between "baud rate clock" and "baud rate" should be mentioned. In the asynchronous modes the serial interfaces require a clock rate which is 16 times the baud rate for internal synchronization. Therefore, the baud rate generators/timers have to provide a "baud rate clock" (output signal in **figure 15** to the serial interface which - there divided by 16 - results in the actual "baud rate". Further, the abbreviation f_{OSC} refers to the oscillator frequency (crystal or external clock operation).

The variable baud rates for modes 1 and 3 of the serial interface can be derived either from timer 1 or from a dedicated baud rate generator (see **figure 15**).

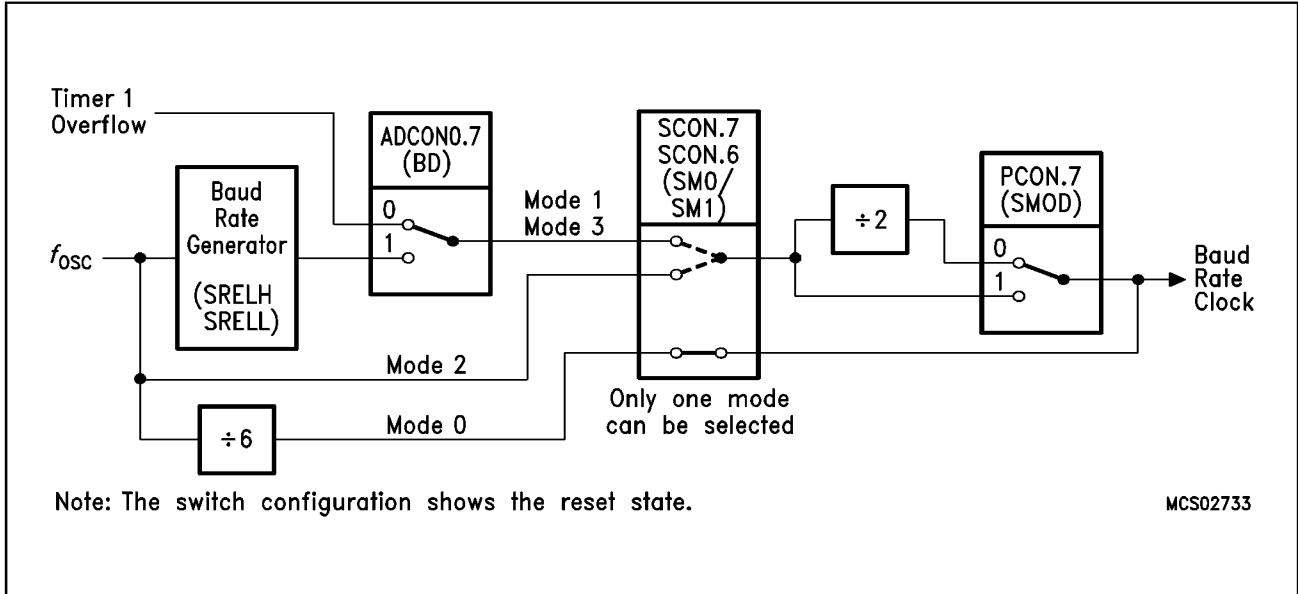

Figure 15
Block Diagram of Baud Rate Generation for the Serial Interface

Table 8 below lists the values/formulas for the baud rate calculation of the serial interface with its dependencies of the control bits BD and SMOD.

Table 8
Serial Interface - Baud Rate Dependencies

Serial Interface Operating Modes	Active Control Bits		Baud Rate Calculation
	BD	SMOD	
Mode 0 (Shift Register)	—	—	$f_{osc} / 6$
Mode 1 (8-bit UART) Mode 3 (9-bit UART)	0	X	Controlled by timer 1 overflow : $(2^{SMOD} \times \text{timer 1 overflow rate}) / 32$
	1	X	Controlled by baud rate generator $(2^{SMOD} \times f_{osc}) / (32 \times \text{baud rate generator overflow rate})$
Mode 2 (9-bit UART)	—	0	$f_{osc} / 32$
		1	$f_{osc} / 16$

SSC Interface

The C515C microcontroller provides a Synchronous Serial Channel unit, the SSC. This interface is compatible to the popular SPI serial bus interface. **Figure 16** shows the block diagram of the SSC. The central element of the SSC is an 8-bit shift register. The input and the output of this shift register are each connected via a control logic to the pin P4.2 / SRI (SSC Receiver In) and P4.3 / STO (SSC Transmitter Out). This shift register can be written to (SFR STB) and can be read through the Receive Buffer Register SRB.

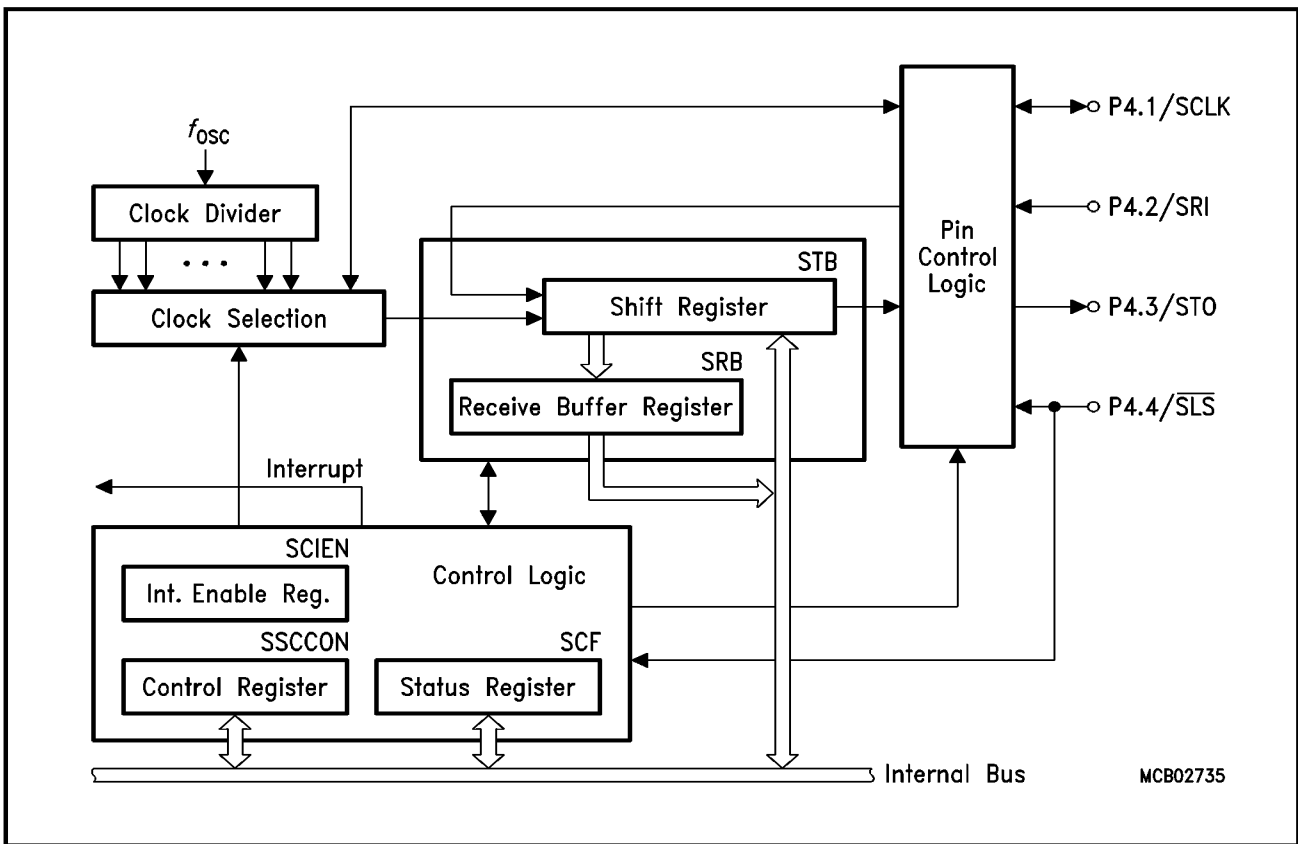

Figure 16
SSC Block Diagram

The SSC has implemented a clock control circuit, which can generate the clock via a baud rate generator in the master mode, or receive the transfer clock in the slave mode. The clock signal is fully programmable for clock polarity and phase. The pin used for the clock signal is P4.1/ SCLK. When operating in slave mode, a slave select input is provided which enables the SSC interface and also will control the transmitter output. The pin used for this is P4.4 / SLS.

The SSC control block is responsible for controlling the different modes and operation of the SSC, checking the status, and generating the respective status and interrupt signals.

CAN Controller

The on-chip CAN controller is the functional heart which provides all resources that are required to run the standard CAN protocol (11-bit identifiers) as well as the extended CAN protocol (29-bit identifiers). It provides a sophisticated object layer to relieve the CPU of as much overhead as possible when controlling many different message objects (up to 15). This includes bus arbitration, resending of garbled messages, error handling, interrupt generation, etc. In order to implement the physical layer, external components have to be connected to the C515C.

The internal bus interface connects the on-chip CAN controller to the internal bus of the microcontroller. The registers and data locations of the CAN interface are mapped to a specific 256 byte wide address range of the external data memory area (F700_H to F7FF_H) and can be accessed using MOVX instructions. Figure 17 shows a block diagram of the on-chip CAN controller.

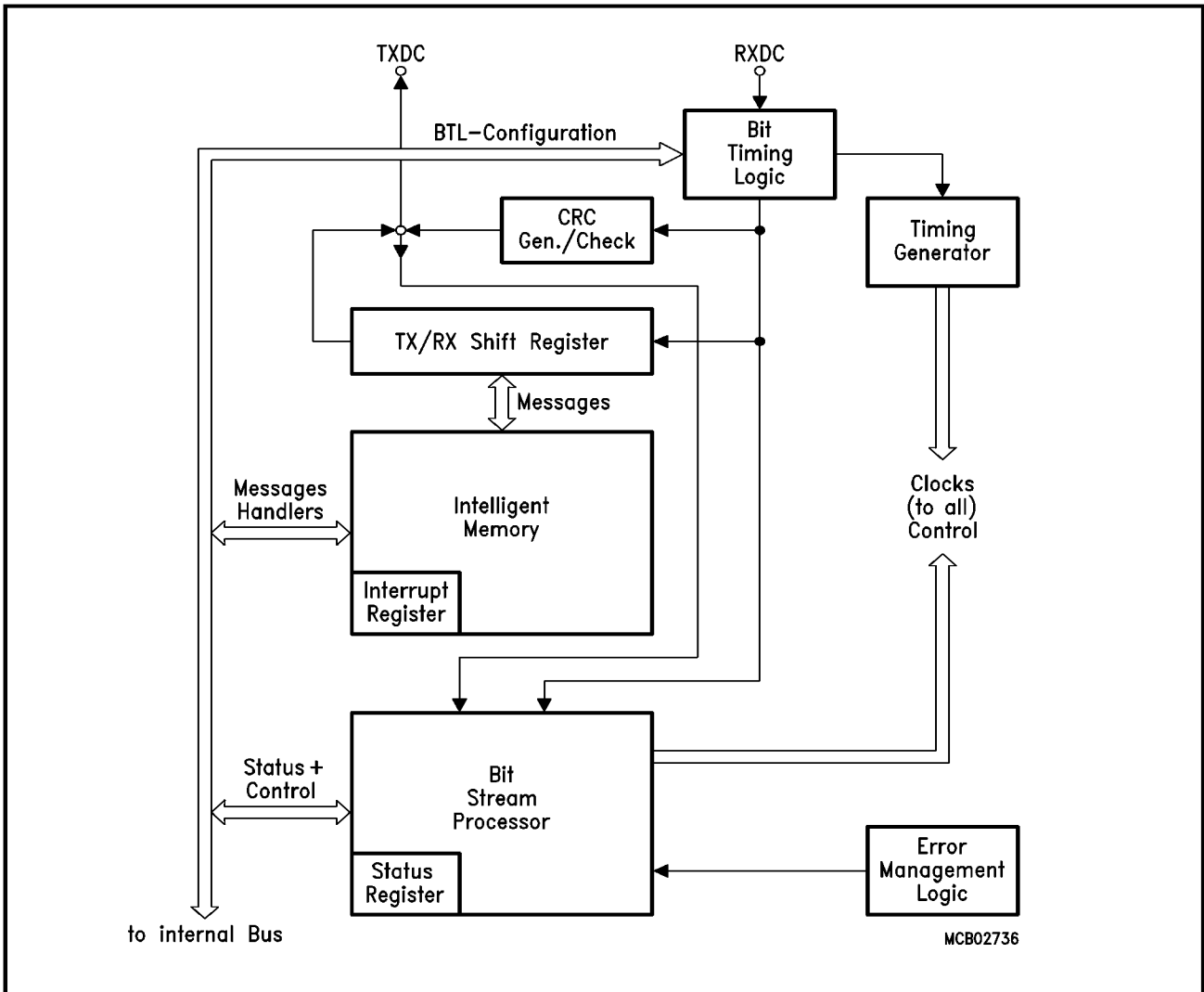

Figure 17
CAN Controller Block Diagram

The **TX/RX Shift Register** holds the destuffed bit stream from the bus line to allow the parallel access to the whole data or remote frame for the acceptance match test and the parallel transfer of the frame to and from the Intelligent Memory.

The **Bit Stream Processor (BSP)** is a sequencer controlling the sequential data stream between the TX/RX Shift Register, the CRC Register, and the bus line. The BSP also controls the EML and the parallel data stream between the TX/RX Shift Register and the Intelligent Memory such that the processes of reception, arbitration, transmission, and error signalling are performed according to the CAN protocol. Note that the automatic retransmission of messages which have been corrupted by noise or other external error conditions on the bus line is handled by the BSP.

The **Cyclic Redundancy Check Register (CRC)** generates the Cyclic Redundancy Check code to be transmitted after the data bytes and checks the CRC code of incoming messages. This is done by dividing the data stream by the code generator polynomial.

The **Error Management Logic (EML)** is responsible for the fault confinement of the CAN device. Its counters, the Receive Error Counter and the Transmit Error Counter, are incremented and decremented by commands from the Bit Stream Processor. According to the values of the error counters, the CAN controller is set into the states error *active*, error *passive* and busoff.

The **Bit Timing Logic (BTL)** monitors the busline input RXDC and handles the busline related bit timing according to the CAN protocol. The BTL synchronizes on a *recessive* to *dominant* busline transition at *Start of Frame* (hard synchronization) and on any further *recessive* to *dominant* busline transition, if the CAN controller itself does not transmit a *dominant* bit (resynchronization). The BTL also provides programmable time segments to compensate for the propagation delay time and for phase shifts and to define the position of the Sample Point in the bit time. The programming of the BTL depends on the baudrate and on external physical delay times.

The **Intelligent Memory** (CAM/RAM array) provides storage for up to 15 message objects of maximum 8 data bytes length. Each of these objects has a unique identifier and its own set of control and status bits. After the initial configuration, the Intelligent Memory can handle the reception and transmission of data without further microcontroller actions.

10-Bit A/D Converter

The C515C includes a high performance / high speed 10-bit A/D-Converter (ADC) with 8 analog input channels. It operates with a successive approximation technique and uses self calibration mechanisms for reduction and compensation of offset and linearity errors. The A/D converter provides the following features:

- 8 multiplexed input channels (port 6), which can also be used as digital inputs
- 10-bit resolution
- Single or continuous conversion mode
- Internal or external start-of-conversion trigger capability
- Interrupt request generation after each conversion
- Using successive approximation conversion technique via a capacitor array
- Built-in hidden calibration of offset and linearity errors

The main functional blocks of the A/D converter are shown in **figure 19**.

The A/D converter uses basically two clock signals for operation : the input clock f_{IN} ($=1/t_{IN}$) and the conversion clock f_{ADC} ($=1/t_{ADC}$). These clock signals are derived from the C515C system clock f_{OSC} which is applied at the XTAL pins. The input clock f_{IN} is equal to f_{OSC} . The conversion clock is limited to a maximum frequency of 2 MHz and therefore must be adapted to f_{OSC} by programming the conversion clock prescaler. The table in **figure 18** shows the prescaler ratios and the resulting A/D conversion times which must be selected for typical system clock rates.

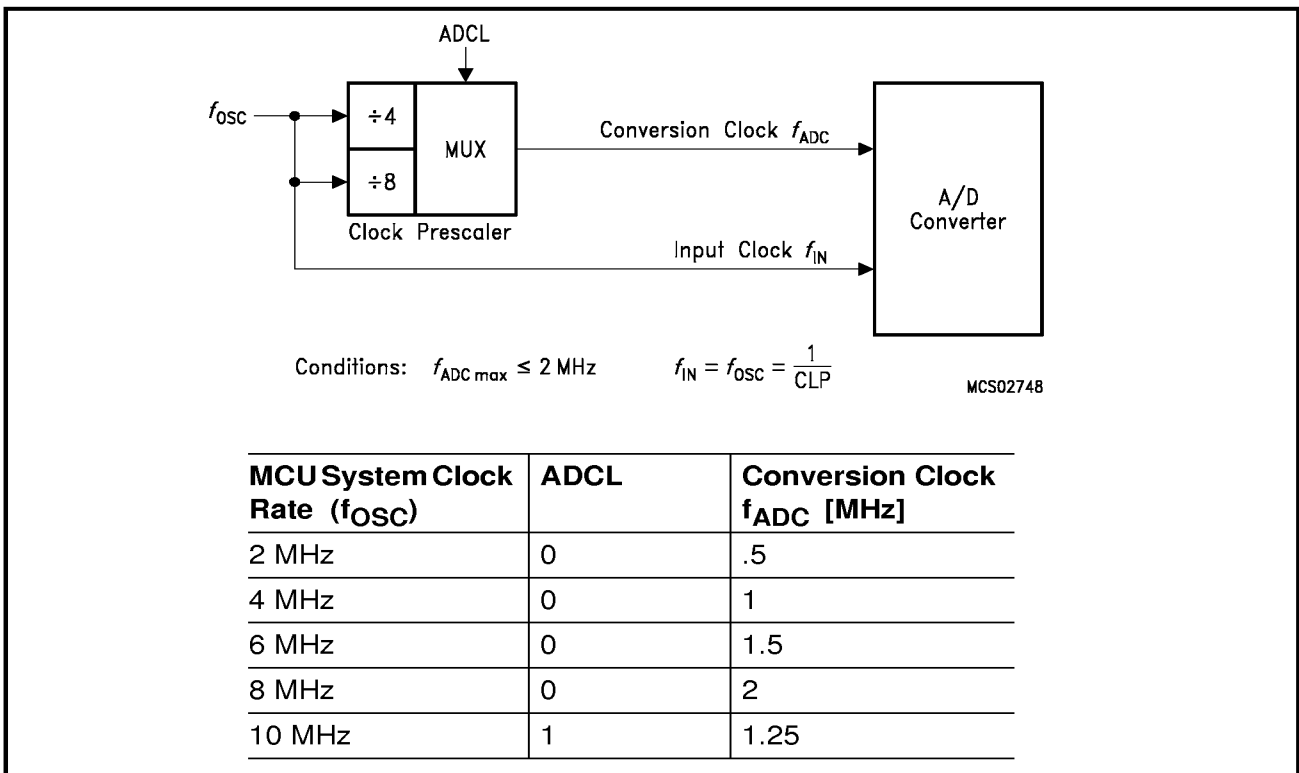

Figure 18
A/D Converter Clock Selection

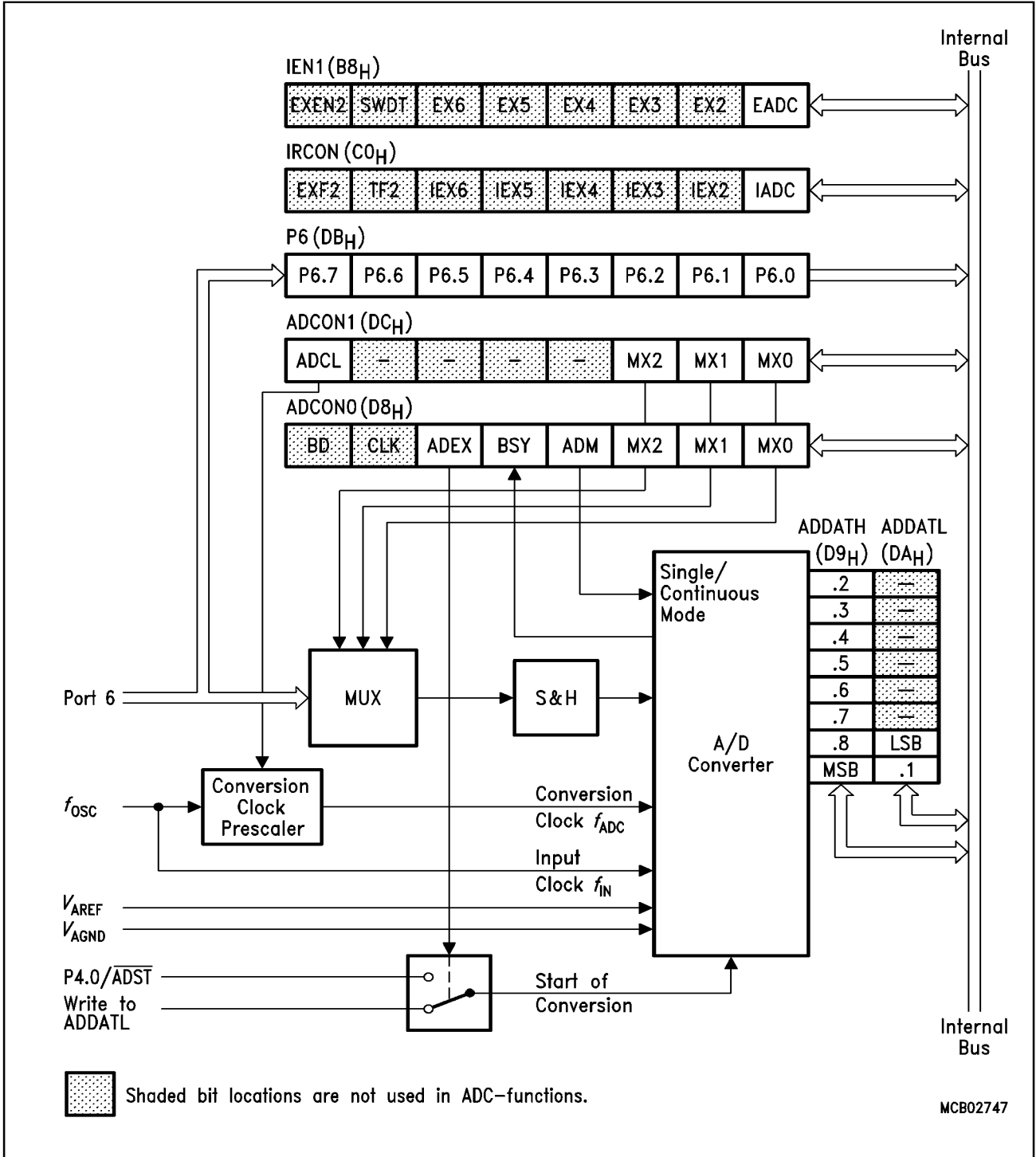

Figure 19
A/D Converter Block Diagram

Interrupt System

The C515C provides 17 interrupt sources with four priority levels. Seven interrupts can be generated by the on-chip peripherals (timer 0, timer 1, timer 2, serial interface, A/D converter, SSC interface, CAN controller), and ten interrupts may be triggered externally (P1.5/T2EX, P3.2/INT0, P3.3/INT1, P1.4/INT2, P1.0/ $\overline{\text{INT}}3$, P1.1/INT4, P1.2/INT5, P1.3/INT6, P7.0/ $\overline{\text{INT}}7$, P4.5/ $\overline{\text{INT}}8$). The wake-up from power-down mode interrupt has a special functionality which allows to exit from the software power-down mode by a short low pulse at pin P3.2/ $\overline{\text{INT}}0$.

In the C515C the 17 interrupt sources are combined to six groups of two or three interrupt sources. Each interrupt group can be programmed to one of the four interrupt priority levels. **Figure 20 to 22** give a general overview of the interrupt sources and illustrate the interrupt request and control flags.

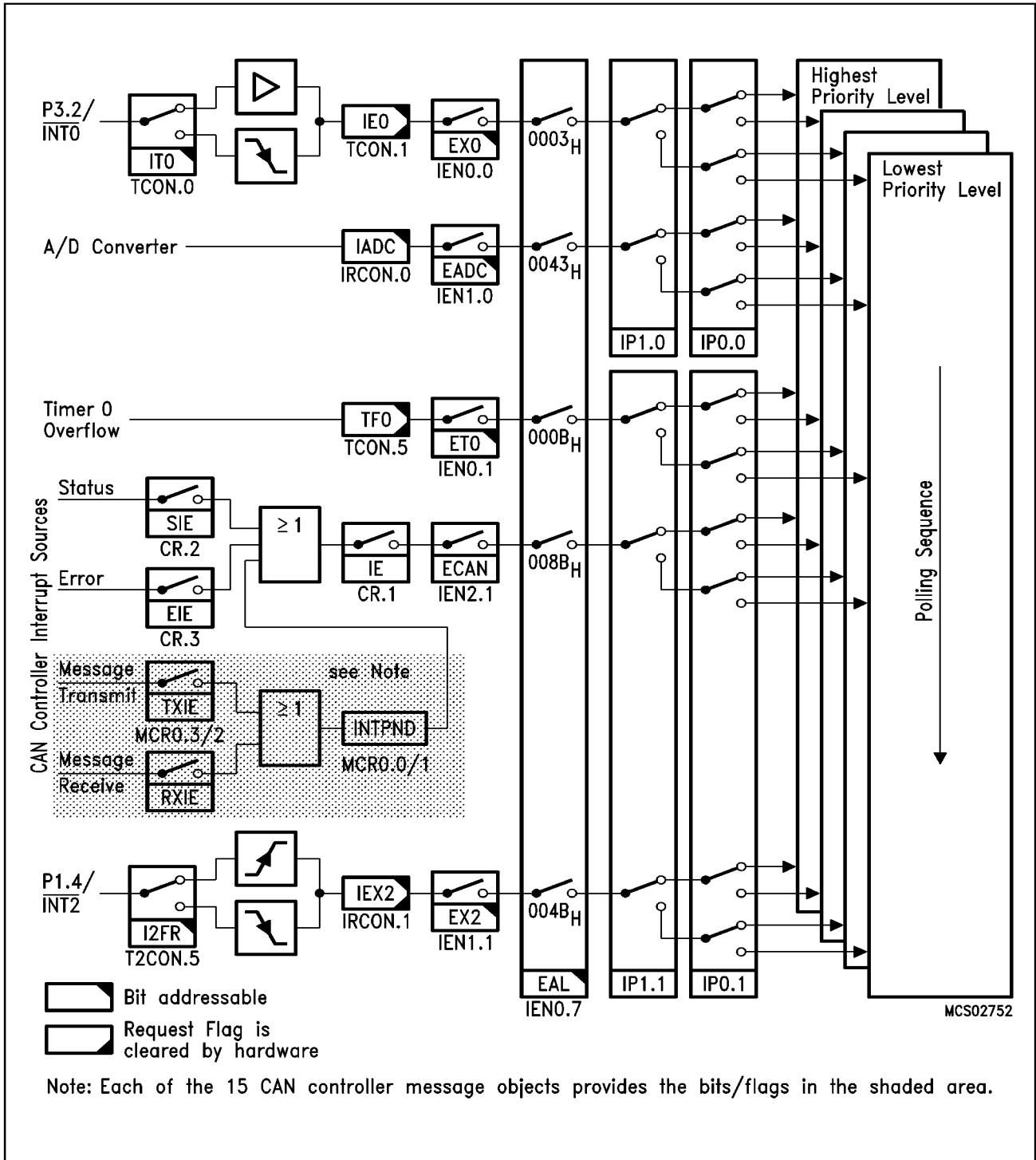

Figure 20
Interrupt Request Sources (Part 1)

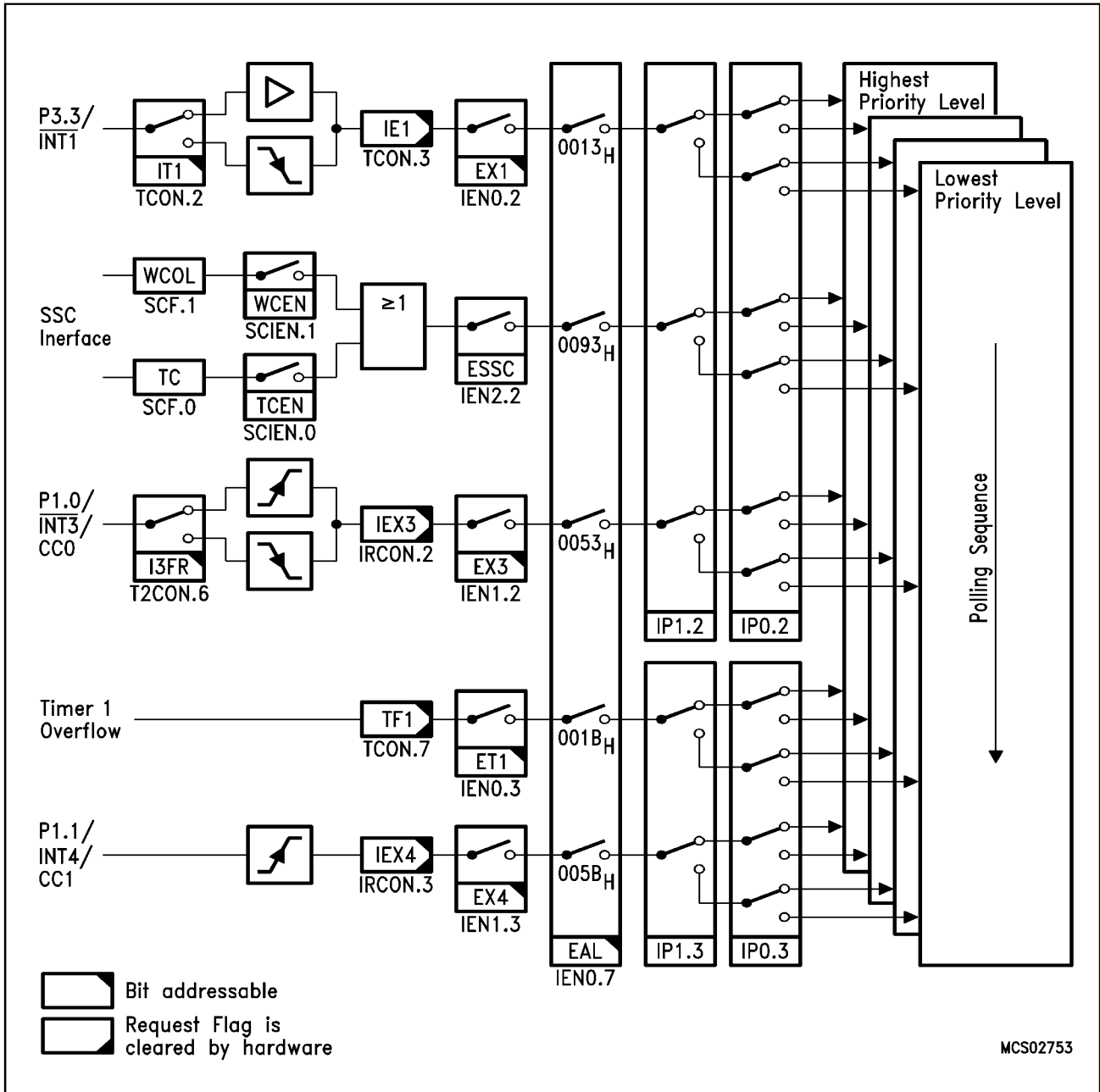

Figure 21
Interrupt Request Sources (Part 2)

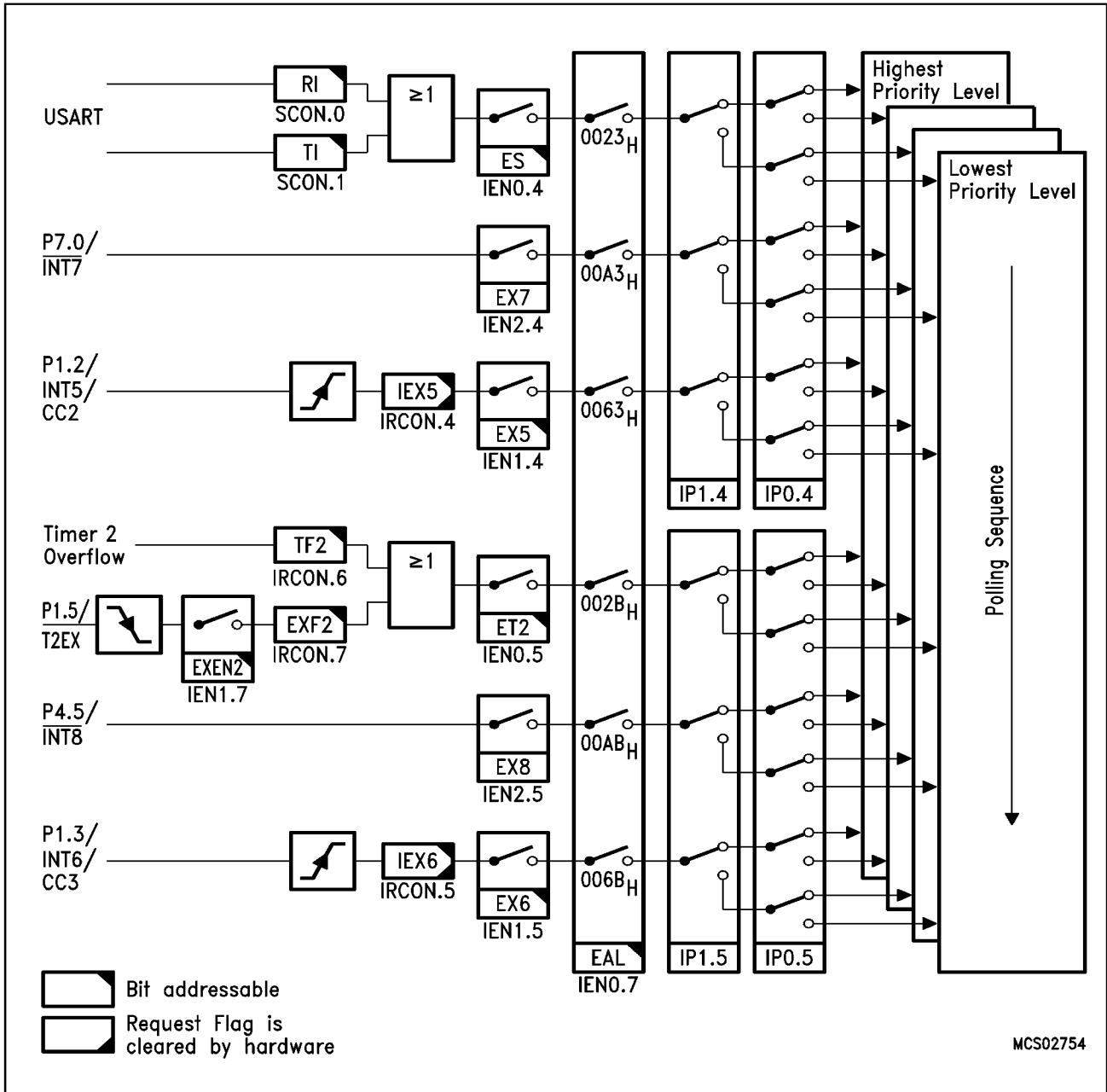

Figure 22
Interrupt Request Sources (Part 3)

Table 9
Interrupt Source and Vectors

Interrupt Source	Interrupt Vector Address	Interrupt Request Flags
External Interrupt 0	0003 _H	IE0
Timer 0 Overflow	000B _H	TF0
External Interrupt 1	0013 _H	IE1
Timer 1 Overflow	001B _H	TF1
Serial Channel	0023 _H	RI / TI
Timer 2 Overflow / Ext. Reload	002B _H	TF2 / EXF2
A/D Converter	0043 _H	IADC
External Interrupt 2	004B _H	IEX2
External Interrupt 3	0053 _H	IEX3
External Interrupt 4	005B _H	IEX4
External Interrupt 5	0063 _H	IEX5
External Interrupt 6	006B _H	IEX6
Wake-up from power-down mode	007B _H	–
CAN controller	008B _H	–
External Interrupt 7	00A3 _H	–
External Interrupt 8	00AB _H	–
SSC interface	0093 _H	TC / WCOL

Oscillator Watchdog

The oscillator watchdog unit serves for four functions:

- **Monitoring of the on-chip oscillator's function**

The watchdog supervises the on-chip oscillator's frequency; if it is lower than the frequency of the auxiliary RC oscillator in the watchdog unit, the internal clock is supplied by the RC oscillator and the device is brought into reset; if the failure condition disappears (i.e. the on-chip oscillator has a higher frequency than the RC oscillator), the part executes a final reset phase of typ. 1 ms in order to allow the oscillator to stabilize; then the oscillator watchdog reset is released and the part starts program execution again.

- **Fast internal reset after power-on**

The oscillator watchdog unit provides a clock supply for the reset before the on-chip oscillator has started. The oscillator watchdog unit also works identically to the monitoring function.

- **Restart from the hardware power down mode.**

If the hardware power down mode is terminated the oscillator watchdog has to control the correct start-up of the on-chip oscillator and to restart the program. The oscillator watchdog function is only part of the complete hardware power down sequence; however, the watchdog works identically to the monitoring function.

- **Control of external wake-up from software power-down mode**

When the software power-down mode is left by a low level at the P3.2/ $\overline{\text{INT0}}$ pin, the oscillator watchdog unit assures that the microcontroller resumes operation (execution of the power-down wake-up interrupt) with the nominal clock rate. In the power-down mode the RC oscillator and the on-chip oscillator are stopped. Both oscillators are started again when power-down mode is released. When the on-chip oscillator has a higher frequency than the RC oscillator, the microcontroller starts operation after a final delay of typ. 1 ms in order to allow the on-chip oscillator to stabilize.

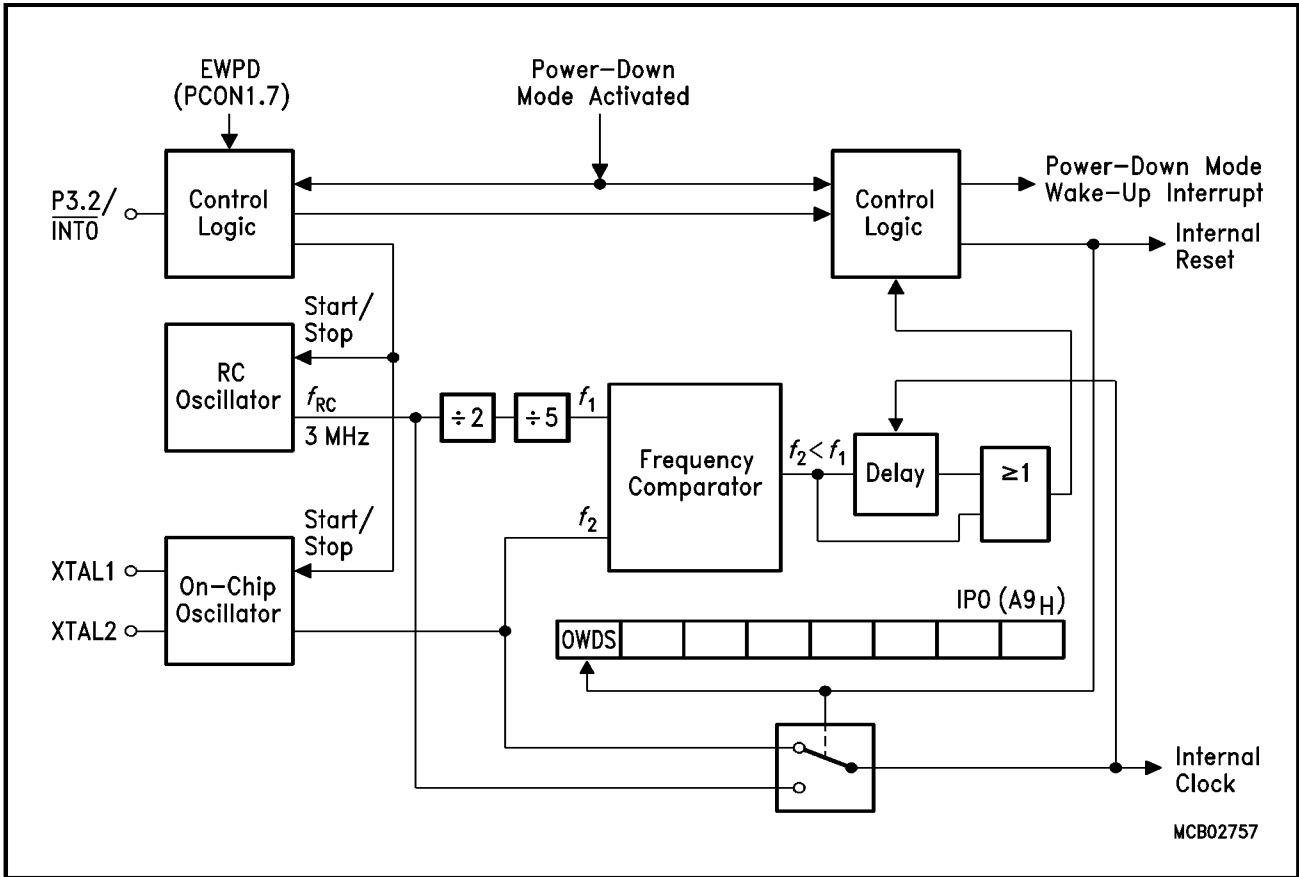

Figure 24
Block Diagram of the Oscillator Watchdog

Power Saving Modes

The C515C provides two basic power saving modes, the idle mode and the power down mode. Additionally, a slow down mode is available. This power saving mode reduces the internal clock rate in normal operating mode and it can be also used for further power reduction in idle mode.

– **Idle mode**

The CPU is gated off from the oscillator. All peripherals are still provided with the clock and are able to work. Idle mode is entered by software and can be left by an interrupt or reset.

– **Power down mode**

The operation of the C515C is completely stopped and the oscillator is turned off. This mode is used to save the contents of the internal RAM with a very low standby current.

Software power down mode : Software power down mode is entered by software and can be left by reset or by a short low pulse at pin P3.2/ $\overline{\text{INT0}}$.

Hardware power down mode : Hardware power down mode is entered when the pin $\overline{\text{HWPD}}$ is put to low level.

– **Slow-down mode**

The controller keeps up the full operating functionality, but its normal clock frequency is internally divided by 32. This slows down all parts of the controller, the CPU and all peripherals, to 1/32-th of their normal operating frequency. Slowing down the frequency significantly reduces power consumption. The slow down mode can be combined with the idle mode.

Table 10 gives a general overview of the entry and exit conditions of the power saving modes.

Table 10
Power Saving Modes Overview

Mode	Entering (2-Instruction Example	Leaving by	Remarks
Idle mode	ORL PCON, #01H ORL PCON, #20H	Ocurrence of an interrupt from a peripheral unit	CPU clock is stopped; CPU maintains their data; peripheral units are active (if enabled) and provided with clock
		Hardware Reset	
Software Power-Down Mode	ORL PCON, #02H ORL PCON, #40H	Hardware Reset	Oscillator is stopped; contents of on-chip RAM and SFR's are maintained;
		Short low pulse at pin P3.2/INT0	
Hardware Power-Down Mode	$\overline{\text{HWPD}} = \text{low}$	$\overline{\text{HWPD}} = \text{high}$	C515C is put into its reset state and the oscillator is stopped; ports become floating outputs
Slow Down Mode	ORL PCON,#10H	ANL PCON,#0EFH or Hardware Reset	Oscillator frequency is reduced to 1/32 of its nominal frequency

In the power down mode of operation, V_{CC} can be reduced to minimize power consumption. It must be ensured, however, that V_{CC} is not reduced before the power down mode is invoked, and that V_{CC} is restored to its normal operating level, before the power down mode is terminated.

If e.g. the idle mode is left through an interrupt, the microcontroller state (CPU, ports, peripherals) remains preserved. If a power saving mode is left by a hardware reset, the microcontroller state is disturbed and replaced by the reset state of the C515C.

Absolute Maximum Ratings

Ambient temperature under bias (T_A)	– 40 to 110 °C
Storage temperature (T_{stg})	– 65 °C to 150 °C
Voltage on V_{CC} pins with respect to ground (V_{SS})	– 0.5 V to 6.5 V
Voltage on any pin with respect to ground (V_{SS})	– 0.5 V to $V_{CC} + 0.5$ V
Input current on any pin during overload condition	– 10 mA to 10 mA
Absolute sum of all input currents during overload condition	100 mA
Power dissipation.....	TBD

Note: Stresses above those listed under “Absolute Maximum Ratings” may cause permanent damage of the device. This is a stress rating only and functional operation of the device at these or any other conditions above those indicated in the operational sections of this specification is not implied. Exposure to absolute maximum rating conditions for longer periods may affect device reliability. During overload conditions ($V_{IN} > V_{CC}$ or $V_{IN} < V_{SS}$) the Voltage on V_{CC} pins with respect to ground (V_{SS}) must not exceed the values defined by the absolute maximum ratings.

DC Characteristics

$V_{CC} = 5\text{ V} + 10\%, -15\%$; $V_{SS} = 0\text{ V}$

$T_A = 0\text{ to }70\text{ }^\circ\text{C}$

$T_A = -40\text{ to }85\text{ }^\circ\text{C}$

$T_A = -40\text{ to }110\text{ }^\circ\text{C}$

for the SAB-C515C-8R

for the SAF-C515C-8R

for the SAH-C515C-8R

Parameter	Symbol	Limit Values		Unit	Test Condition
		min.	max.		
Input low voltages all except \overline{EA} , \overline{RESET} , \overline{HWPD}	V_{IL}	-0.5	$0.2 V_{CC} - 0.1$	V	-
\overline{EA} pin	V_{IL1}	-0.5	$0.2 V_{CC} - 0.3$	V	-
\overline{RESET} and \overline{HWPD} pins	V_{IL2}	-0.5	$0.2 V_{CC} + 0.1$	V	-
Port 5 in CMOS mode	V_{ILC}	-0.5	$0.3 V_{CC}$	V	-
Input high voltages all except XTAL2, \overline{RESET} , and \overline{HWPD})	V_{IH}	$0.2 V_{CC} + 0.9$	$V_{CC} + 0.5$	V	-
XTAL2 pin	V_{IH1}	$0.7 V_{CC}$	$V_{CC} + 0.5$	V	-
\overline{RESET} and \overline{HWPD} pins	V_{IH2}	$0.6 V_{CC}$	$V_{CC} + 0.5$	V	-
Port 5 in CMOS mode	V_{IHC}	$0.7 V_{CC}$	$V_{CC} + 0.5$	V	-
Output low voltages Ports 1, 2, 3, 4, 5, 7 (incl. CMOS)	V_{OL}	-	0.45	V	$I_{OL} = 1.6\text{ mA}^1$
Port 0, ALE, \overline{PSEN} , \overline{CPUR}	V_{OL1}	-	0.45	V	$I_{OL} = 3.2\text{ mA}^1$
P4.1, P4.3 in push-pull mode	V_{OL3}	-	0.45	V	$I_{OL} = 3.75\text{ mA}^1$
Output high voltages Ports 1, 2, 3, 4, 5, 7	V_{OH}	2.4	-	V	$I_{OH} = -80\text{ }\mu\text{A}$
		$0.9 V_{CC}$	-	V	$I_{OH} = -10\text{ }\mu\text{A}^1$
Port 0 in external bus mode, ALE, \overline{PSEN} , \overline{CPUR}	V_{OH2}	2.4	-	V	$I_{OH} = -800\text{ }\mu\text{A}$
		$0.9 V_{CC}$	-	V	$I_{OH} = -80\text{ }\mu\text{A}^2$
Port 5 in CMOS mode	V_{OHC}	$0.9 V_{CC}$	-	V	$I_{OH} = -800\text{ }\mu\text{A}$
P4.1, P4.3 in push-pull mode	V_{OH3}	$0.9 V_{CC}$	-	V	$I_{OH} = -833\text{ }\mu\text{A}$
Logic 0 input current Ports 1, 2, 3, 4, 5, 7	I_{IL}	-10	-70	μA	$V_{IN} = 0.45\text{ V}$
Logical 0-to-1 transition current Ports 1, 2, 3, 4, 5, 7	I_{TL}	-65	-650	μA	$V_{IN} = 2\text{ V}$
Input leakage current Port 0, \overline{EA} , P6, \overline{HWPD} , AIN0-7	I_{LI}	-	± 1	μA	$0.45 < V_{IN} < V_{CC}$
Input low current To \overline{RESET} for reset	I_{LI2}	-	-100	μA	$V_{IN} = 0.45\text{ V}$
XTAL2	I_{LI3}	-	-15	μA	$V_{IN} = 0.45\text{ V}$
$\overline{PE}/\overline{SWD}$	I_{LI4}	-	-20	μA	$V_{IN} = 0.45\text{ V}$
Pin capacitance	C_{IO}	-	10	pF	$f_c = 1\text{ MHz}$, $T_A = 25\text{ }^\circ\text{C}$
Overload current	I_{OV}	-	± 5	mA	^{8) 9)}

Power Supply Current

Parameter		Symbol	Limit Values		Unit	Test Condition
			typ. ¹⁰⁾	max. ¹¹⁾		
Active mode	6 MHz	I_{CC}	12.0	16.1	mA	4)
	10 MHz	I_{CC}	18.9	25.5	mA	
Idle mode	6 MHz	I_{CC}	6.9	9.8	mA	5)
	10 MHz	I_{CC}	10.5	15	mA	
Active mode with slow-down enabled	6 MHz	I_{CC}	TBD	TBD	mA	6)
	10 MHz	I_{CC}	TBD	TBD	mA	
Idle mode with slow-down enabled	6 MHz	I_{CC}	TBD	TBD	mA	7)
	10 MHz	I_{CC}	TBD	TBD	mA	
Power-down mode		I_{PD}	TBD	50	μA	$V_{CC} = 2 \dots 5.5 V^{3)}$

- 1) Capacitive loading on ports 0 and 2 may cause spurious noise pulses to be superimposed on the V_{OL} of ALE and port 3. The noise is due to external bus capacitance discharging into the port 0 and port 2 pins when these pins make 1-to-0 transitions during bus operation. In the worst case (capacitive loading > 100 pF), the noise pulse on ALE line may exceed 0.8 V. In such cases it may be desirable to qualify ALE with a schmitt-trigger, or use an address latch with a schmitt-trigger strobe input.
- 2) Capacitive loading on ports 0 and 2 may cause the V_{OH} on ALE and \overline{PSEN} to momentarily fall below the 0.9 V_{CC} specification when the address lines are stabilizing.
- 3) I_{PD} (power-down mode) is measured under following conditions:
 $\overline{EA} = \overline{RESET} = \text{Port 0} = \text{Port 6} = V_{CC}$; XTAL1 = N.C.; XTAL2 = V_{SS} ; $\overline{PE/SWD} = V_{SS}$; $\overline{HWPD} = V_{CC}$; $V_{AGND} = V_{SS}$; $V_{AREF} = V_{CC}$; all other pins are disconnected.
 I_{PD} (hardware power-down mode) is independent of any particular pin connection.
- 4) I_{CC} (active mode) is measured with:
 XTAL2 driven with t_{CLCH} , $t_{CHCL} = 5 \text{ ns}$, $V_{IL} = V_{SS} + 0.5 \text{ V}$, $V_{IH} = V_{CC} - 0.5 \text{ V}$; XTAL1 = N.C.;
 $\overline{EA} = \overline{PE/SWD} = \text{Port 0} = \text{Port 6} = V_{CC}$; $\overline{HWPD} = V_{CC}$; $\overline{RESET} = V_{SS}$; all other pins are disconnected.
- 5) I_{CC} (idle mode) is measured with all output pins disconnected and with all peripherals disabled;
 XTAL2 driven with t_{CLCH} , $t_{CHCL} = 5 \text{ ns}$, $V_{IL} = V_{SS} + 0.5 \text{ V}$, $V_{IH} = V_{CC} - 0.5 \text{ V}$; XTAL1 = N.C.;
 $\overline{RESET} = V_{CC}$; $\overline{EA} = V_{SS}$; Port0 = V_{CC} ; all other pins are disconnected;
- 6) I_{CC} (active mode with slow-down mode) is measured : TBD
- 7) I_{CC} (idle mode with slow-down mode) is measured : TBD
- 8) Overload conditions occur if the standard operating conditions are exceeded, ie. the voltage on any pin exceeds the specified range (i.e. $V_{OV} > V_{CC} + 0.5 \text{ V}$ or $V_{OV} < V_{SS} - 0.5 \text{ V}$). The supply voltage V_{CC} and V_{SS} must remain within the specified limits. The absolute sum of input currents on all port pins may not exceed 50 mA.
- 9) Not 100% tested, guaranteed by design characterization
- 10) The typical I_{CC} values are periodically measured at $T_A = +25 \text{ }^\circ\text{C}$ and $V_{CC} = 5 \text{ V}$ but not 100% tested.
- 11) The maximum I_{CC} values are measured under worst case conditions ($T_A = 0 \text{ }^\circ\text{C}$ or $-40 \text{ }^\circ\text{C}$ and $V_{CC} = 5.5 \text{ V}$)

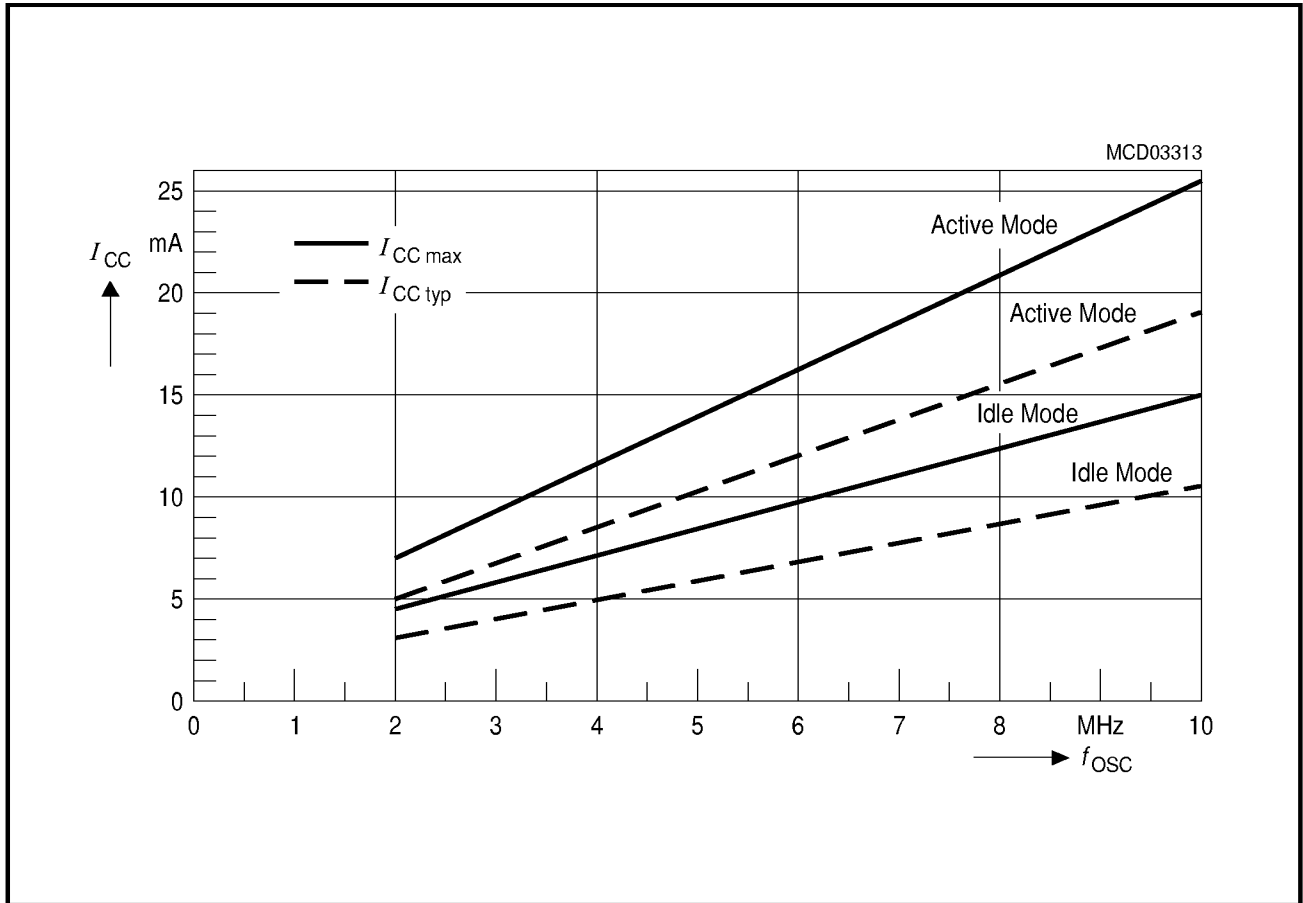

Figure 25
ICC Diagram

Power Supply Current Calculation Formulas

Parameter	Symbol	Formula
Active mode	$I_{CC\ typ}$	$1.72 \cdot f_{OSC} + 1.72$
	$I_{CC\ max}$	$2.33 \cdot f_{OSC} + 2.15$
Idle mode	$I_{CC\ typ}$	$0.9 \cdot f_{OSC} + 1.5$
	$I_{CC\ max}$	$1.3 \cdot f_{OSC} + 2.0$
Active mode with slow-down enabled	$I_{CC\ typ}$	TBD
	$I_{CC\ max}$	TBD
Idle mode with slow-down enabled	$I_{CC\ typ}$	TBD
	$I_{CC\ max}$	TBD

Note : f_{osc} is the oscillator frequency in MHz. I_{CC} values are given in mA.

A/D Converter Characteristics

$$V_{CC} = 5\text{ V} + 10\%, -15\%; V_{SS} = 0\text{ V}$$

$$T_A = 0\text{ to }70\text{ }^\circ\text{C}$$

$$T_A = -40\text{ to }85\text{ }^\circ\text{C}$$

$$T_A = -40\text{ to }110\text{ }^\circ\text{C}$$

for the SAB-C515C-8R

for the SAF-C515C-8R

for the SAH-C515C-8R

$$4\text{ V} \leq V_{AREF} \leq V_{CC} + 0.1\text{ V}; V_{SS} - 0.1\text{ V} \leq V_{AGND} \leq V_{SS} + 0.2\text{ V}$$

Parameter	Symbol	Limit Values		Unit	Test Condition
		min.	max.		
Analog input voltage	V_{AIN}	V_{AGND}	V_{AREF}	V	1)
Sample time	t_S	–	$16 \times t_{IN}$ $8 \times t_{IN}$	ns	Prescaler $\div 8$ Prescaler $\div 4$ 2)
Conversion cycle time	t_{ADCC}	–	$96 \times t_{IN}$ $48 \times t_{IN}$	ns	Prescaler $\div 8$ Prescaler $\div 4$ 3)
Total unadjusted error	T_{UE}	–	± 2	LSB	4)
Internal resistance of reference voltage source	R_{AREF}	–	$t_{ADC} / 250$ - 0.25	k Ω	t_{ADC} in [ns] 5) 6)
Internal resistance of analog source	R_{ASRC}	–	$t_S / 500$ - 0.25	k Ω	t_S in [ns] 2) 6)
ADC input capacitance	C_{AIN}	–	50	pF	6)

Notes see next page.

Clock calculation table :

Clock Prescaler Ratio	ADCL	t_{ADC}	t_S	t_{ADCC}
$\div 8$	1	$8 \times t_{IN}$	$16 \times t_{IN}$	$96 \times t_{IN}$
$\div 4$	0	$4 \times t_{IN}$	$8 \times t_{IN}$	$48 \times t_{IN}$

Further timing conditions : $t_{ADC} \text{ min} = 500\text{ ns}$

$$t_{IN} = 1 / f_{OSC} = t_{CLP}$$

Notes:

- 1) V_{AIN} may exceed V_{AGND} or V_{AREF} up to the absolute maximum ratings. However, the conversion result in these cases will be $X000_H$ or $X3FF_H$, respectively.
- 2) During the sample time the input capacitance C_{AIN} can be charged/discharged by the external source. The internal resistance of the analog source must allow the capacitance to reach their final voltage level within t_S . After the end of the sample time t_S , changes of the analog input voltage have no effect on the conversion result.
- 3) This parameter includes the sample time t_S , the time for determining the digital result and the time for the calibration. Values for the conversion clock t_{ADC} depend on programming and can be taken from the table on the previous page.
- 4) T_{UE} is tested at $V_{AREF} = 5.0\text{ V}$, $V_{AGND} = 0\text{ V}$, $V_{CC} = 4.9\text{ V}$. It is guaranteed by design characterization for all other voltages within the defined voltage range.
If an overload condition occurs on maximum 2 not selected analog input pins and the absolute sum of input overload currents on all analog input pins does not exceed 10 mA, an additional conversion error of 1/2 LSB is permissible.
- 5) During the conversion the ADC's capacitance must be repeatedly charged or discharged. The internal resistance of the reference source must allow the capacitance to reach their final voltage level within the indicated time. The maximum internal resistance results from the programmed conversion timing.
- 6) Not 100% tested, but guaranteed by design characterization.

AC Characteristics

$V_{CC} = 5\text{ V} + 10\%, -15\%$; $V_{SS} = 0\text{ V}$

$T_A = 0\text{ to }70\text{ }^\circ\text{C}$

$T_A = -40\text{ to }85\text{ }^\circ\text{C}$

$T_A = -40\text{ to }110\text{ }^\circ\text{C}$

for the SAB-C515C-8R

for the SAF-C515C-8R

for the SAH-C515C-8R

(C_L for port 0, ALE and $\overline{\text{PSEN}}$ outputs = 100 pF; C_L for all other outputs = 80 pF)

Program Memory Characteristics

Parameter	Symbol	Limit Values				Unit
		10-MHz clock Duty Cycle 0.4 to 0.6		Variable Clock 1/CLP = 2 MHz to 10 MHz		
		min.	max.	min.	max.	
ALE pulse width	t_{LHLL}	60	–	CLP - 40	–	ns
Address setup to ALE	t_{AVLL}	15	–	$TCL_{Hmin} - 25$	–	ns
Address hold after ALE	t_{LLAX}	15	–	$TCL_{Hmin} - 25$	–	ns
ALE to valid instruction in	t_{LLIV}	–	113	–	2 CLP - 87	ns
ALE to $\overline{\text{PSEN}}$	t_{LLPL}	20	–	$TCL_{Lmin} - 20$	–	ns
$\overline{\text{PSEN}}$ pulse width	t_{PLPH}	115	–	CLP+ $TCL_{Hmin} - 30$	–	ns
$\overline{\text{PSEN}}$ to valid instruction in	t_{PLIV}	–	75	–	CLP+ $TCL_{Hmin} - 65$	ns
Input instruction hold after $\overline{\text{PSEN}}$	t_{PXIX}	0	–	0	–	ns
Input instruction float after $\overline{\text{PSEN}}$	t_{PXIZ} *)	–	30	–	$TCL_{Lmin} - 10$	ns
Address valid after $\overline{\text{PSEN}}$	t_{PXAV} *)	35	–	$TCL_{Lmin} - 5$	–	ns
Address to valid instruction in	t_{AVIV}	–	180	–	2 CLP + $TCL_{Hmin} - 60$	ns
Address float to $\overline{\text{PSEN}}$	t_{AZPL}	0	–	0	–	ns

*) Interfacing the C515C to devices with float times up to 35 ns is permissible. This limited bus contention will not cause any damage to port 0 drivers.

External Data Memory Characteristics

Parameter	Symbol	Limit Values				Unit
		10-MHz clock Duty Cycle 0.4 to 0.6		Variable Clock 1/CLP= 2 MHz to 10 MHz		
		min.	max.	min.	max.	
\overline{RD} pulse width	t_{RLRH}	230	–	3 CLP - 70	–	ns
\overline{WR} pulse width	t_{WLWH}	230	–	3 CLP - 70	–	ns
Address hold after ALE	t_{LLAX2}	48	–	CLP - 15	–	ns
\overline{RD} to valid data in	t_{RLDV}	–	150	–	2 CLP+ TCL _{Hmin} - 90	ns
Data hold after \overline{RD}	t_{RHDX}	0		0	–	ns
Data float after \overline{RD}	t_{RHDZ}	–	80	–	CLP - 20	ns
ALE to valid data in	t_{LLDV}	–	267	–	4 CLP - 133	ns
Address to valid data in	t_{AVDV}	–	285	–	4 CLP + TCL _{Hmin} -155	ns
ALE to \overline{WR} or \overline{RD}	t_{LLWL}	90	190	CLP + TCL _{Lmin} - 50	CLP+ TCL _{Lmin} + 50	ns
Address valid to \overline{WR}	t_{AVWL}	103	–	2 CLP - 97	–	ns
\overline{WR} or \overline{RD} high to ALE high	t_{WHLH}	15	65	TCL _{Hmin} - 25	TCL _{Hmin} + 25	ns
Data valid to \overline{WR} transition	t_{QVWX}	5	–	TCL _{Lmin} - 35	–	ns
Data setup before \overline{WR}	t_{QVWH}	218	–	3 CLP + TCL _{Lmin} - 122	–	ns
Data hold after \overline{WR}	t_{WHQX}	13	–	TCL _{Hmin} - 27	–	ns
Address float after \overline{RD}	t_{RLAZ}	–	0	–	0	ns

SSC Interface Characteristics

Parameter	Symbol	Limit Values		Unit
		min.	max.	
Clock Cycle Time : Master Mode Slave Mode	t_{SCLK}	0.4	–	μ s
	t_{SCLK}	1.0	–	μ s
Clock high time	t_{SCH}	360	–	ns
Clock low time	t_{SCL}	360	–	ns
Data output delay	t_D	–	100	ns
Data output hold	t_{HO}	0	–	ns
Data input setup	t_S	100	–	ns
Data input hold	t_{HI}	100	–	ns
TC bit set delay	t_{DTC}	–	8 CLP	ns

External Clock Drive at XTAL2

Parameter	Symbol	CPU Clock = 10 MHz Duty cycle 0.4 to 0.6		Variable CPU Clock 1/CLP = 2 to 10 MHz		Unit
		min.	max.	min.	max.	
Oscillator period	CLP	100	100	100	500	ns
High time	TCL_H	40	–	40	$CLP - TCL_L$	ns
Low time	TCL_L	40	–	40	$CLP - TCL_H$	ns
Rise time	t_R	–	12	–	12	ns
Fall time	t_F	–	12	–	12	ns
Oscillator duty cycle	DC	0.4	0.6	40 / CLP	1 - 40 / CLP	–
Clock cycle	TCL	40	60	$CLP * DC_{min}$	$CLP * DC_{max}$	ns

Note: The 10 MHz values in the tables are given as an example for a typical duty cycle variation of the oscillator clock from 0.4 to 0.6.

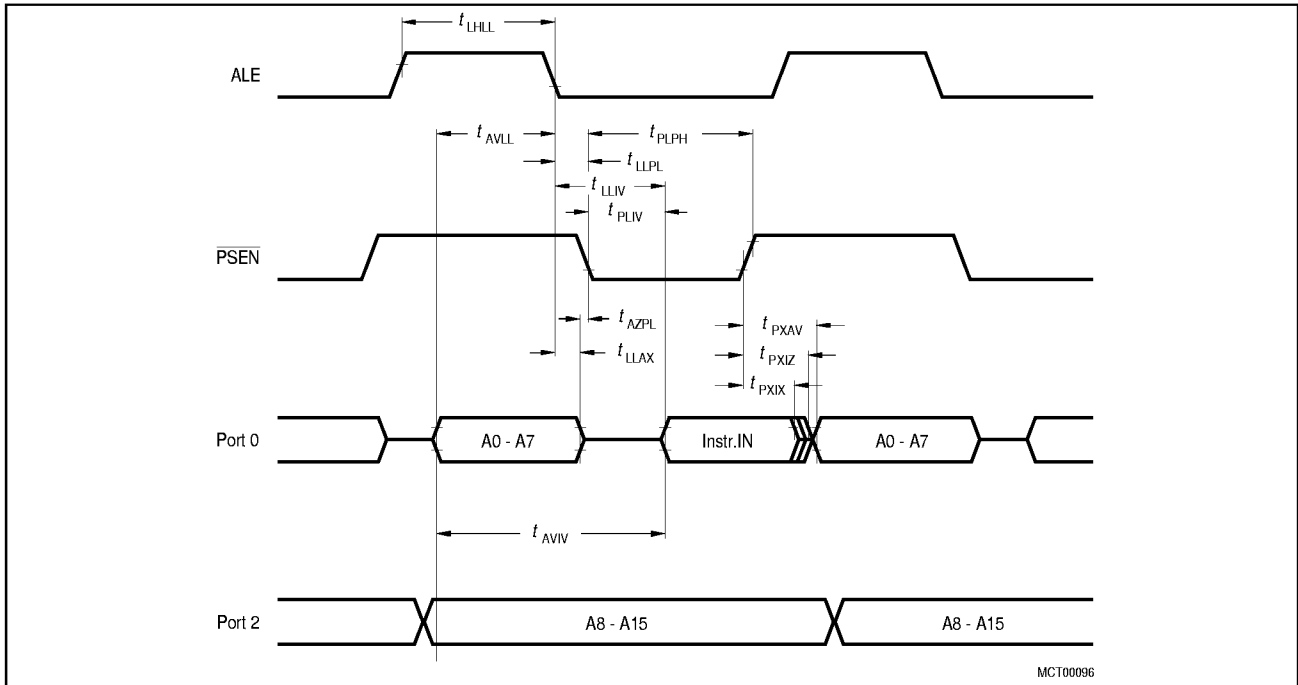

Figure 26
Program Memory Read Cycle

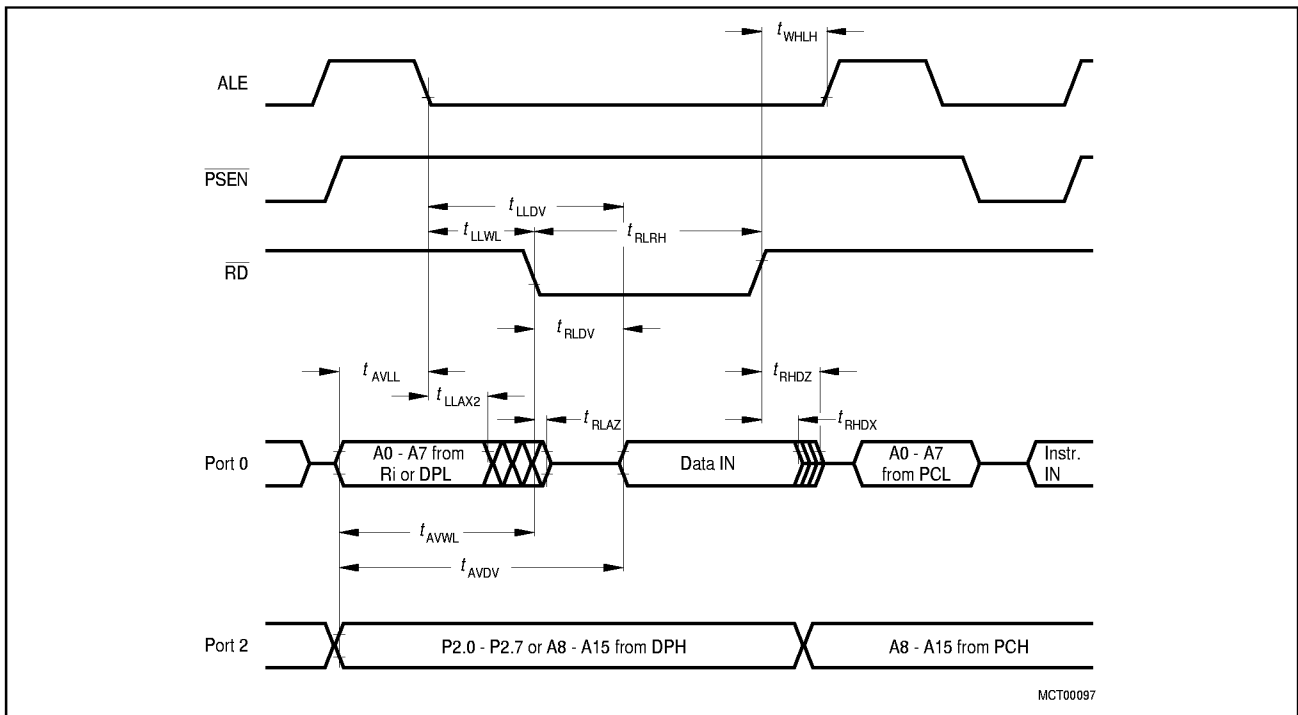

Figure 27
Data Memory Read Cycle

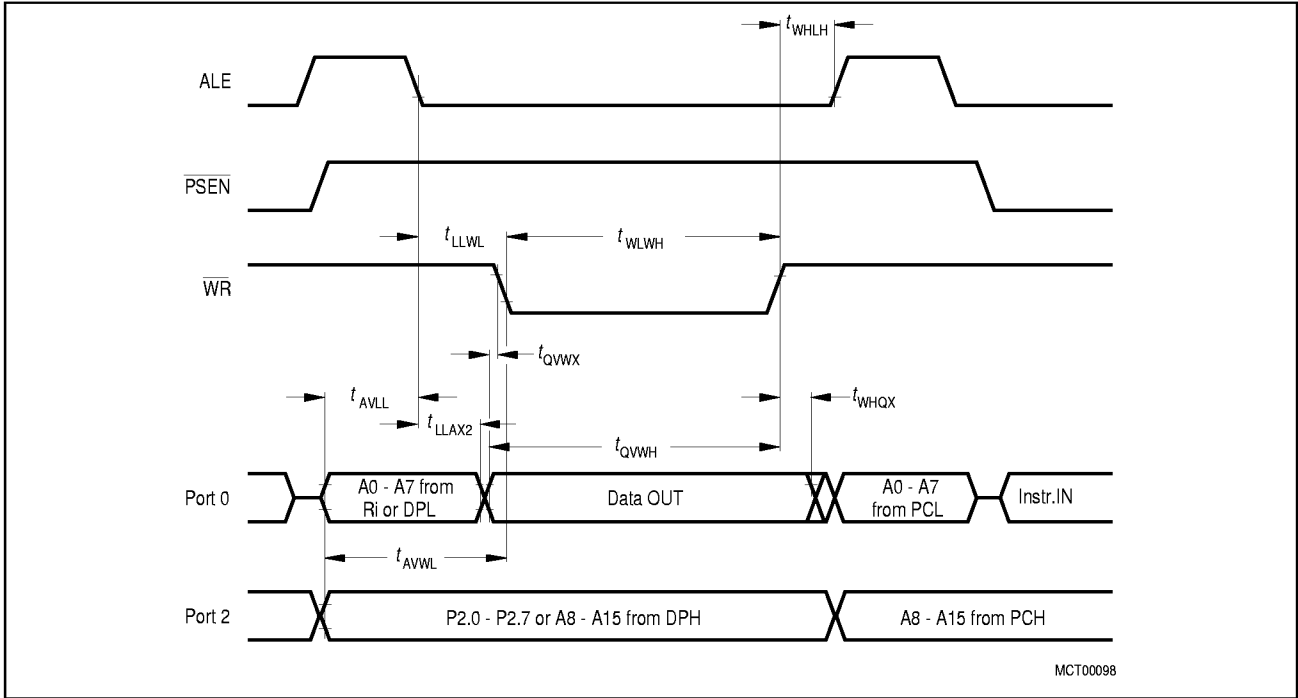

Figure 28
Data Memory Write Cycle

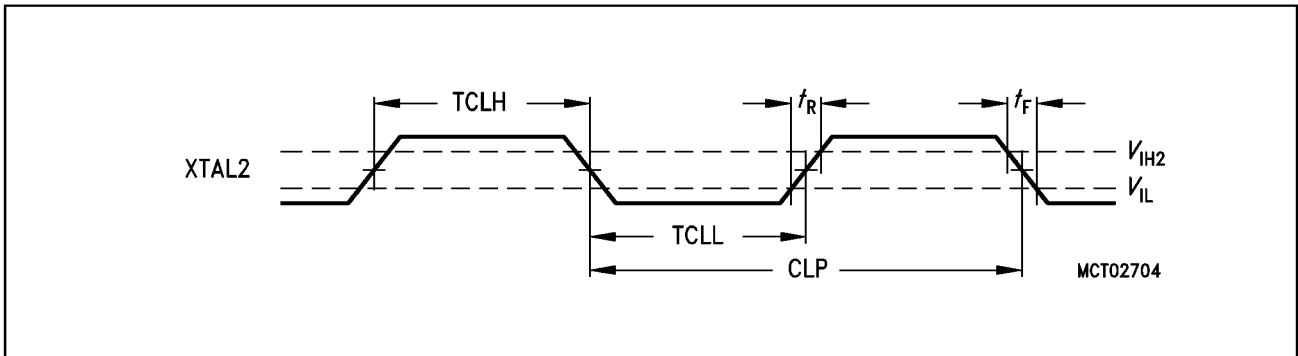
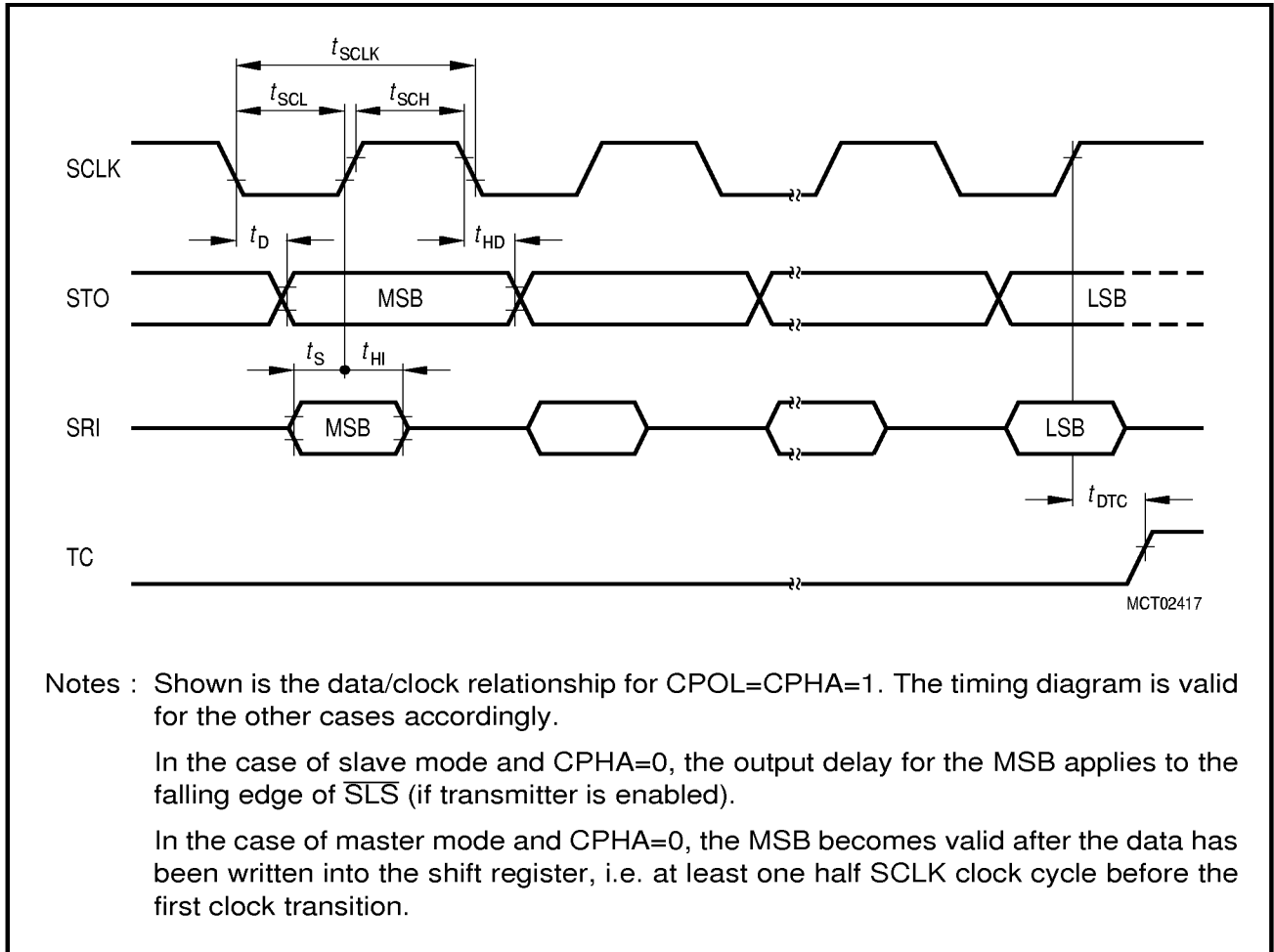

Figure 29
External Clock Drive at XTAL2



Notes : Shown is the data/clock relationship for CPOL=CPHA=1. The timing diagram is valid for the other cases accordingly.

In the case of slave mode and CPHA=0, the output delay for the MSB applies to the falling edge of \overline{SLS} (if transmitter is enabled).

In the case of master mode and CPHA=0, the MSB becomes valid after the data has been written into the shift register, i.e. at least one half SCLK clock cycle before the first clock transition.

Figure 30
SSC Timing

ROM Verification Mode 1

Parameter	Symbol	Limit Values		Unit
		min.	max.	
Address to valid data	t_{AVQV}	—	5 CLP	ns

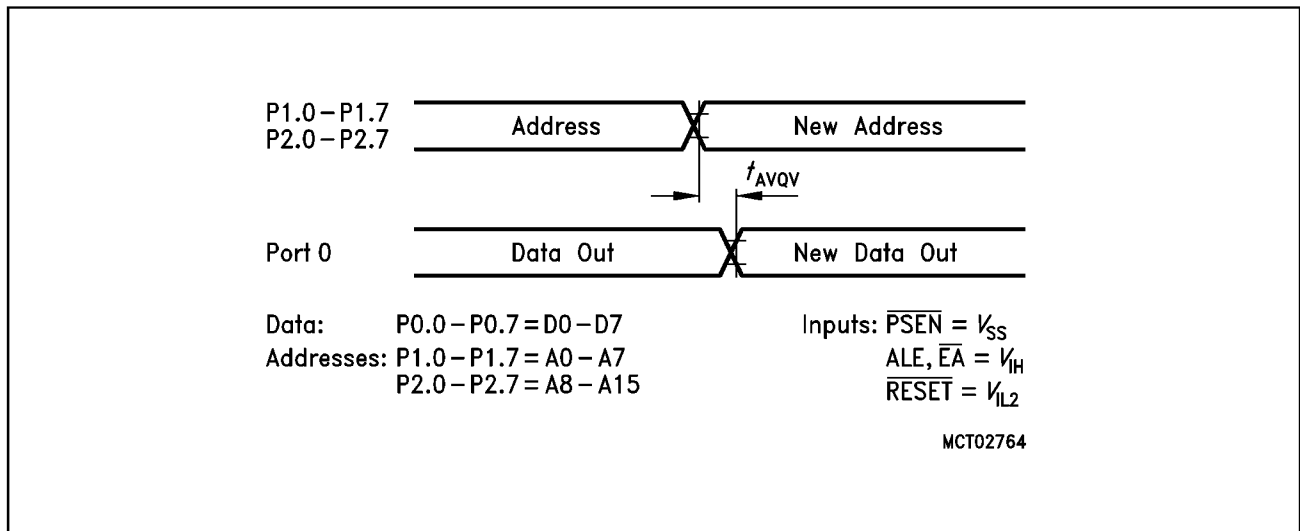

Figure 31
ROM Verification Mode 1

ROM Verification Mode 2

Parameter	Symbol	Limit Values			Unit
		min.	typ	max.	
ALE pulse width	t_{AWD}	–	CLP	–	ns
ALE period	t_{ACY}	–	6 CLP	–	ns
Data valid after ALE	t_{DVA}	–	–	2 CLP	ns
Data stable after ALE	t_{DSA}	4 CLP	–	–	ns
P3.5 setup to ALE low	t_{AS}	–	t_{CL}	–	ns
Oscillator frequency	1/ CLP	4	–	6	MHz

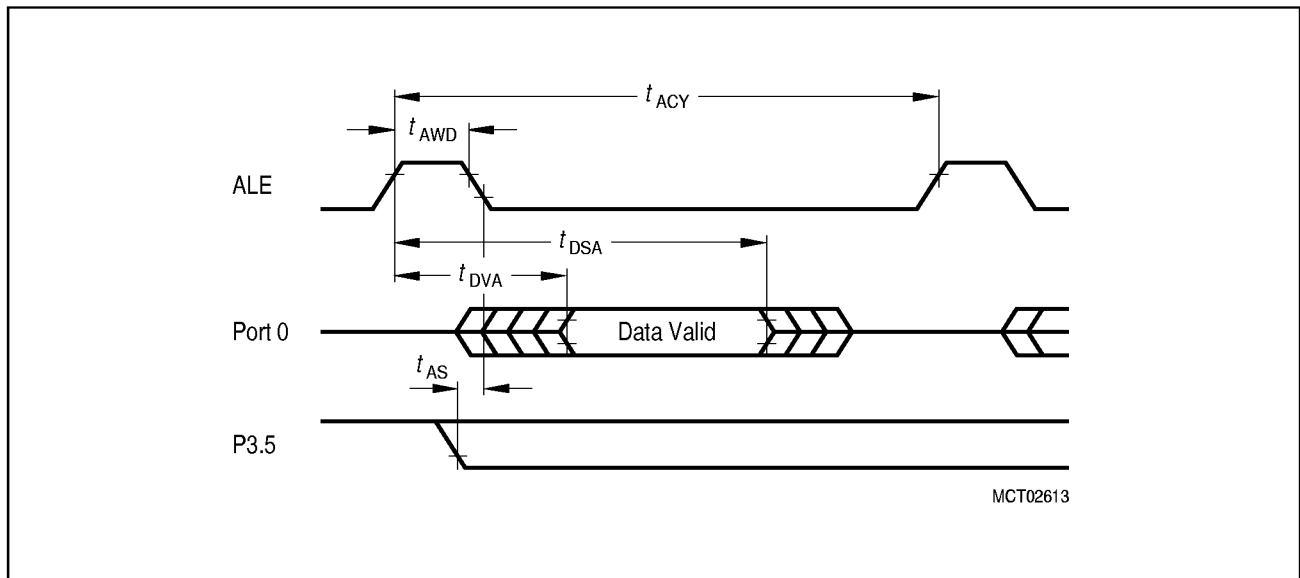

Figure 32
ROM Verification Mode 2

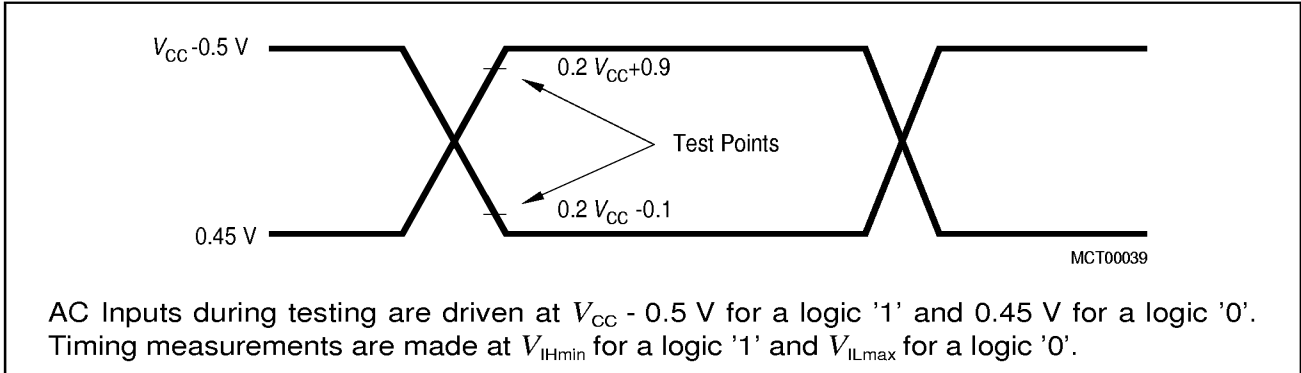

Figure 33
AC Testing: Input, Output Waveforms

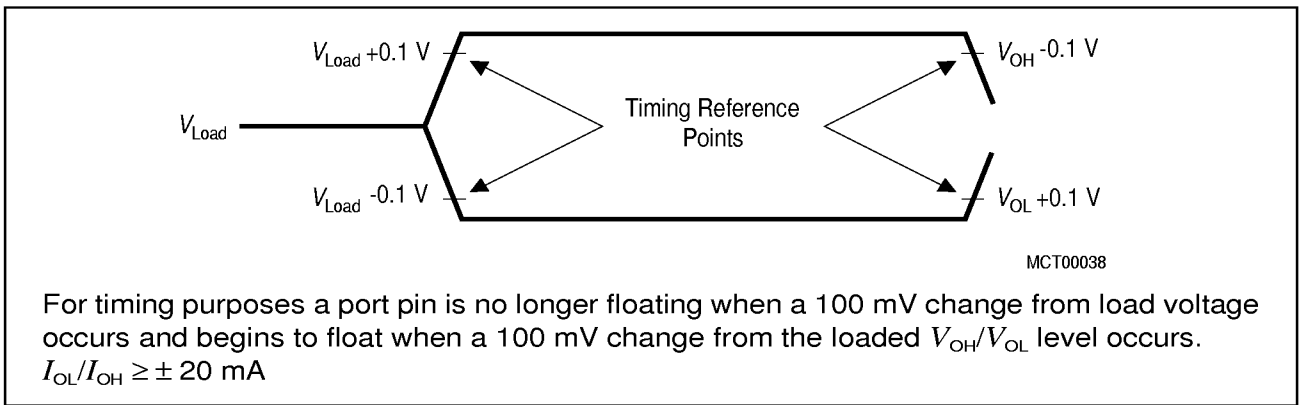

Figure 34
AC Testing : Float Waveforms

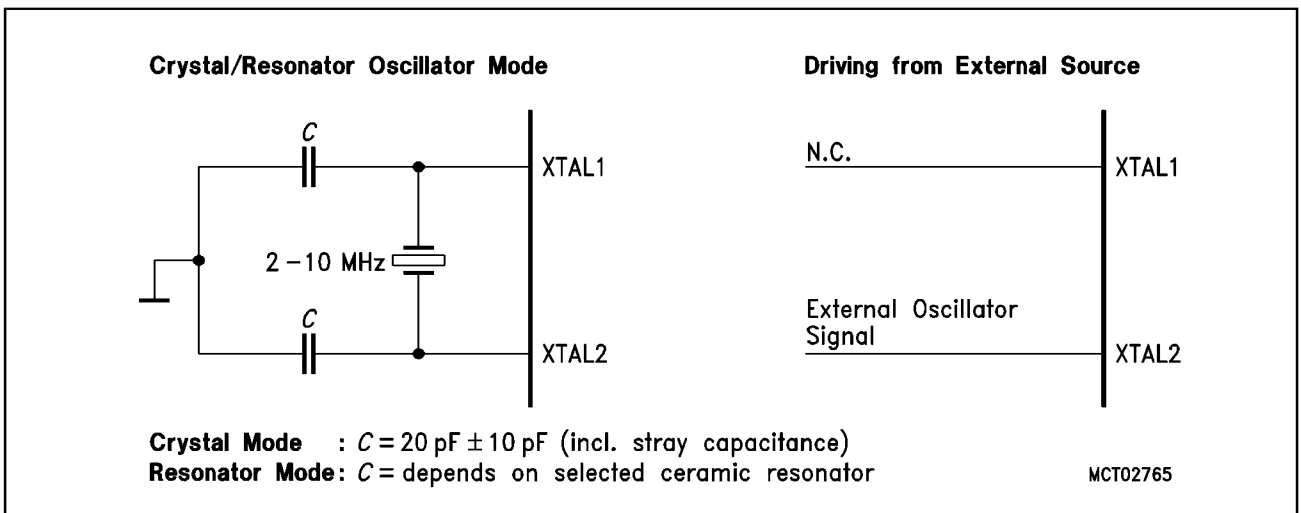

Figure 35
Recommended Oscillator Circuits for Crystal Oscillator

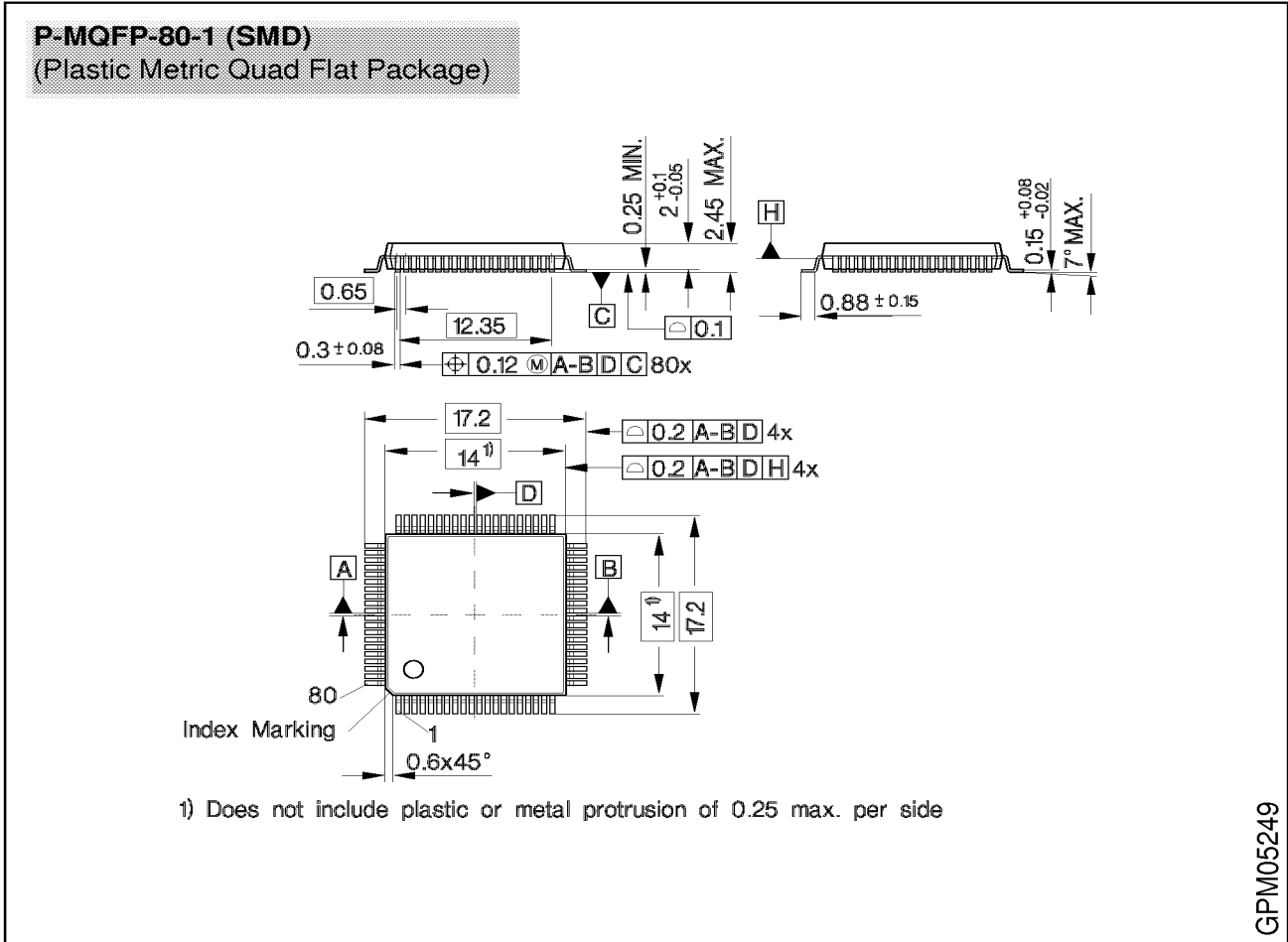

Figure 36
Package Outlines

Sorts of Packing

Package outlines for tubes, trays etc. are contained in our Data Book "Package Information"

SMD = Surface Mounted Device

Dimensions in mm