

4-BIT SINGLE-CHIP MICROCONTROLLER**DESCRIPTION**

The μ PD753017 is one of the 75XL series 4-bit single-chip microcontroller chips and has a data processing capability comparable to that of an 8-bit microcontroller.

It has an on-chip LCD controller/driver with a larger ROM capacity and extended CPU functions compared with the conventional μ PD75316B, and can provide high-speed operation. It can be supplied in a small plastic TQFP package (12 × 12 mm) and is suitable for small sets using LCD panels.

For details of functions refer to the following User's Manual.

μ PD753017 User's Manual : U11282E

FEATURES

- ★
 - Low voltage operation: $V_{DD} = 2.2$ to 5.5 V
 - Can be driven by two 1.5 V batteries
 - On-chip memory
 - Program memory (ROM):
 - 12288 × 8 bits (μ PD753012)
 - 16384 × 8 bits (μ PD753016)
 - 24576 × 8 bits (μ PD753017)
 - Data memory (RAM):
 - 1024 × 4 bits
 - Capable of high-speed operation and variable instruction execution time for power saving
 - 0.95, 1.91, 3.81, 15.3 μ s (at 4.19 MHz operation)
 - 0.67, 1.33, 2.67, 10.7 μ s (at 6.0 MHz operation)
 - 122 μ s (at 32.768 kHz operation)
 - Internal programmable LCD controller/driver
 - Small plastic TQFP (12 × 12 mm)
 - Suitable for small sets such as cameras
 - One-time PROM: μ PD75P3018

APPLICATION

Remote controllers, camera-contained VCRs, cameras, gas meters, etc.

ORDERING INFORMATION

Part number	Package
μ PD753012GC-XXX-3B9	80-pin plastic QFP (14 × 14 mm)
μ PD753012GK-XXX-BE9	80-pin plastic TQFP (fine pitch) (12 × 12 mm)
μ PD753016GC-XXX-3B9	80-pin plastic QFP (14 × 14 mm)
μ PD753016GK-XXX-BE9	80-pin plastic TQFP (fine pitch) (12 × 12 mm)
μ PD753017GC-XXX-3B9	80-pin plastic QFP (14 × 14 mm)
μ PD753017GK-XXX-BE9	80-pin plastic TQFP (fine pitch) (12 × 12 mm)

Remark XXX indicates a ROM code suffix.

In this document, unless otherwise specified, the description is made based on μ PD753017 as typical product.

The information in this document is subject to change without notice.

FUNCTIONAL OUTLINE

Parameter		Function	
Instruction execution time		<ul style="list-style-type: none"> • 0.95, 1.91, 3.81, 15.3 μs (main system clock: at 4.19 MHz operation) • 0.67, 1.33, 2.67, 10.7 μs (main system clock: at 6.0 MHz operation) • 122 μs (subsystem clock: at 32.768 kHz operation) 	
On-chip memory	ROM	12288 × 8 bits (μPD753012)	
		16384 × 8 bits (μPD753016)	
		24576 × 8 bits (μPD753017)	
	RAM	1024 × 4 bits	
General-purpose register		<ul style="list-style-type: none"> • 4-bit operation: 8 × 4 banks • 8-bit operation: 4 × 4 banks 	
★ Input/output port	CMOS input	8	On-chip pull-up resistors can be specified by using software: 23
	CMOS input/output	16	
	CMOS output	8	Also used for segment pins
	N-ch open-drain input/output	8	Withstands 13 V, on-chip pull-up resistors can be specified by using mask option
	Total	40	
LCD controller/driver		<ul style="list-style-type: none"> • Segment number selection : 24/28/32 segments (can be changed to CMOS output port in 4 time-unit; max. 8) • Display mode selection : Static 1/2 duty (1/2 bias) 1/3 duty (1/2 bias) 1/3 duty (1/3 bias) 1/4 duty (1/3 bias) 	
		On-chip split resistor for LCD drive can be specified by using mask option	
Timer		5 channels <ul style="list-style-type: none"> • 8-bit timer/event counter: 3 channels (can be used for 16-bit timer/event counter, carrier generator, or timer with gate) • Basic interval timer/watchdog timer: 1 channel • Watch timer: 1 channel 	
Serial interface		<ul style="list-style-type: none"> • 3-wire serial I/O mode ... MSB or LSB can be selected for transferring top bit • 2-wire serial I/O mode • SBI mode 	
Bit sequential buffer		16 bits	
Clock output (PCL)		<ul style="list-style-type: none"> • Φ, 524, 262, 65.5 kHz (main system clock: at 4.19 MHz operation) • Φ, 750, 375, 93.8 kHz (main system clock: at 6.0 MHz operation) 	
★ Buzzer output (BUZ)		<ul style="list-style-type: none"> • 2, 4, 32 kHz (main system clock: at 4.19 MHz operation or subsystem clock: at 32.768 kHz operation) • 2.93, 5.86, 46.9 kHz (main system clock: at 6.0 MHz operation) 	
Vectored interrupts		External: 3, Internal: 5	
Test input		External: 1, Internal: 1	
System clock oscillator		<ul style="list-style-type: none"> • Ceramic or crystal oscillator for main system clock oscillation • Crystal oscillator for subsystem clock oscillation 	
Standby function		STOP/HALT mode	
★ Power supply voltage		V _{DD} = 2.2 to 5.5 V	
Package		<ul style="list-style-type: none"> • 80-pin plastic QFP (14 × 14 mm) • 80-pin plastic TQFP (fine pitch) (12 × 12 mm) 	

CONTENTS

1.	PIN CONFIGURATION (TOP VIEW)	5
2.	BLOCK DIAGRAM	7
3.	PIN FUNCTION	8
3.1	Port Pins	8
3.2	Pins Other than Port Pins	10
3.3	Pin Input/Output Circuits	12
3.4	Recommended Connection for Unused Pins	14
4.	SWITCHING FUNCTION BETWEEN MK I MODE AND MK II MODE	15
4.1	Differences between Mk I Mode and Mk II Mode	15
4.2	Setting Method of Stack Bank Select Register (SBS)	16
5.	MEMORY CONFIGURATION	17
6.	PERIPHERAL HARDWARE FUNCTIONS	21
6.1	Digital Input/Output Ports	21
6.2	Clock Generator	22
6.3	Subsystem Clock Oscillator Control Functions	23
6.4	Clock Output Circuit	24
6.5	Basic Interval Timer/Watchdog Timer	25
6.6	Watch Timer	26
6.7	Timer/Event Counter	27
6.8	Serial Interface	31
6.9	LCD Controller/Driver	33
6.10	Bit Sequential Buffer ... 16 Bits	35
7.	INTERRUPT FUNCTION AND TEST FUNCTION	36
8.	STANDBY FUNCTION	38
9.	RESET FUNCTION	39
★ 10.	MASK OPTION	42
11.	INSTRUCTION SETS AND THEIR OPERATIONS	43
12.	ELECTRICAL SPECIFICATIONS	55
13.	PACKAGE DRAWINGS	68
14.	RECOMMENDED SOLDERING CONDITIONS	70

APPENDIX A μ PD75316B, 753017 AND 75P3018 FUNCTION LIST72

APPENDIX B DEVELOPMENT TOOLS74

APPENDIX C RELATED DOCUMENTS78

1. PIN CONFIGURATION (TOP VIEW)

- 80-pin plastic QFP (14 × 14 mm)
μPD753012GC-XXX-3B9, 753016GC-XXX-3B9,
μPD753017GC-XXX-3B9
- 80-pin plastic TQFP (fine pitch) (12 × 12 mm)
μPD753012GK-XXX-BE9, 753016GK-XXX-BE9,
μPD753017GK-XXX-BE9

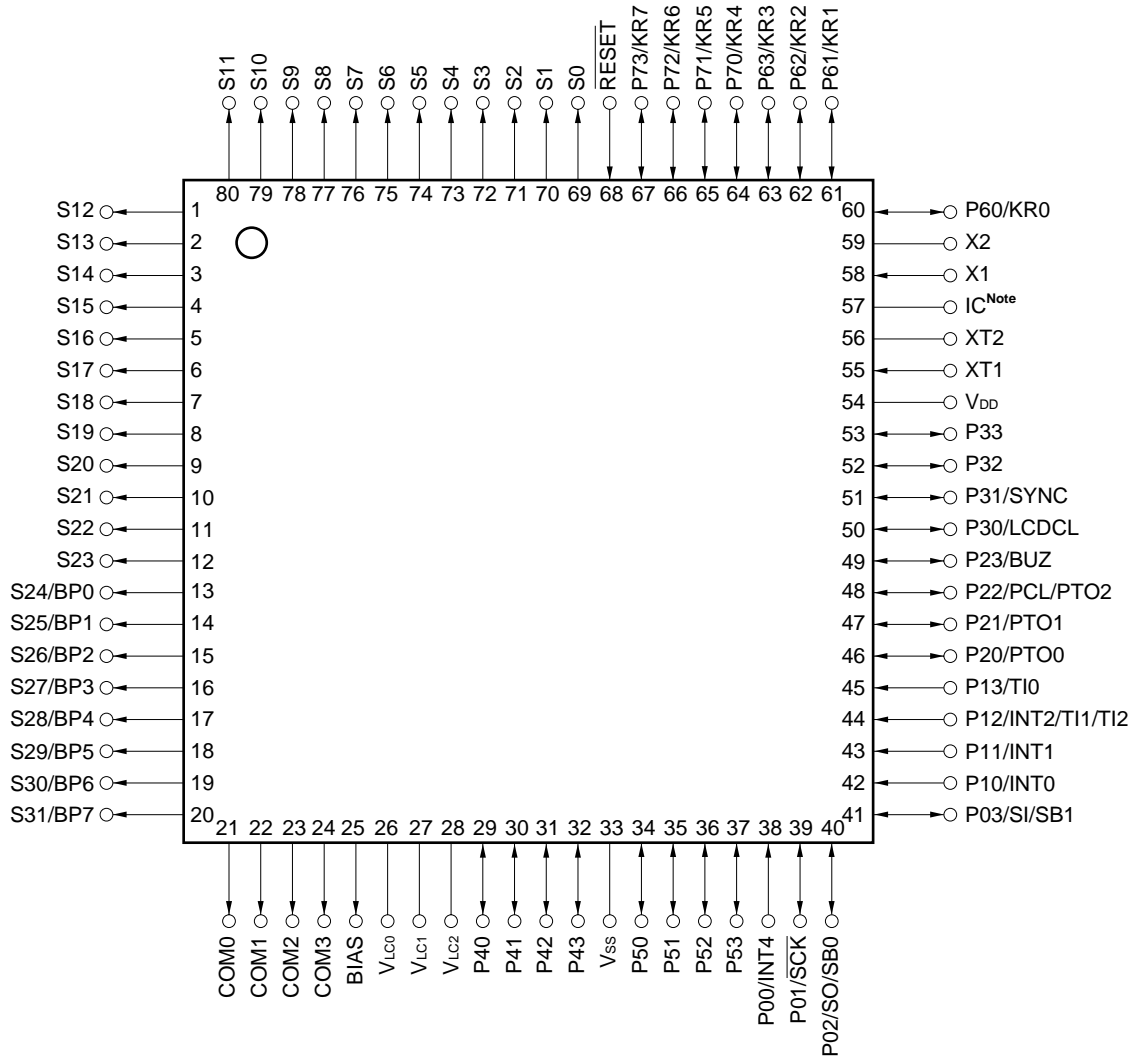

Note Connect the IC (Internally Connected) pin directly to V_{DD}.

Pin Name

P00-P03	: Port 0	V _{LC0-V_{LC2}}	: LCD Power Supply 0-2
P10-P13	: Port 1	BIAS	: LCD Power Supply Bias Control
P20-P23	: Port 2	LCDCL	: LCD Clock
P30-P33	: Port 3	SYNC	: LCD Synchronization
P40-P43	: Port 4	TI0-TI2	: Timer Input 0-2
P50-P53	: Port 5	PTO0-PTO2	: Programmable Timer Output 0-2
P60-P63	: Port 6	BUZ	: Buzzer Clock
P70-P73	: Port 7	PCL	: Programmable Clock
BP0-BP7	: Bit Port	INT0, INT1, INT4	: External Vectored Interrupt 0, 1, 4
KR0-KR7	: Key Return	INT2	: External Test Input 2
\overline{SCK}	: Serial Clock	X1, X2	: Main System Clock Oscillation 1, 2
SI	: Serial Input	XT1, XT2	: Subsystem Clock Oscillation 1, 2
SO	: Serial Output	V _{DD}	: Positive Power Supply
SB0, SB1	: Serial Bus 0, 1	V _{SS}	: Ground
\overline{RESET}	: Reset Input	IC	: Internally Connected
S0-S31	: Segment Output 0-31		
COM0-COM3	: Common Output 0-3		

2. BLOCK DIAGRAM

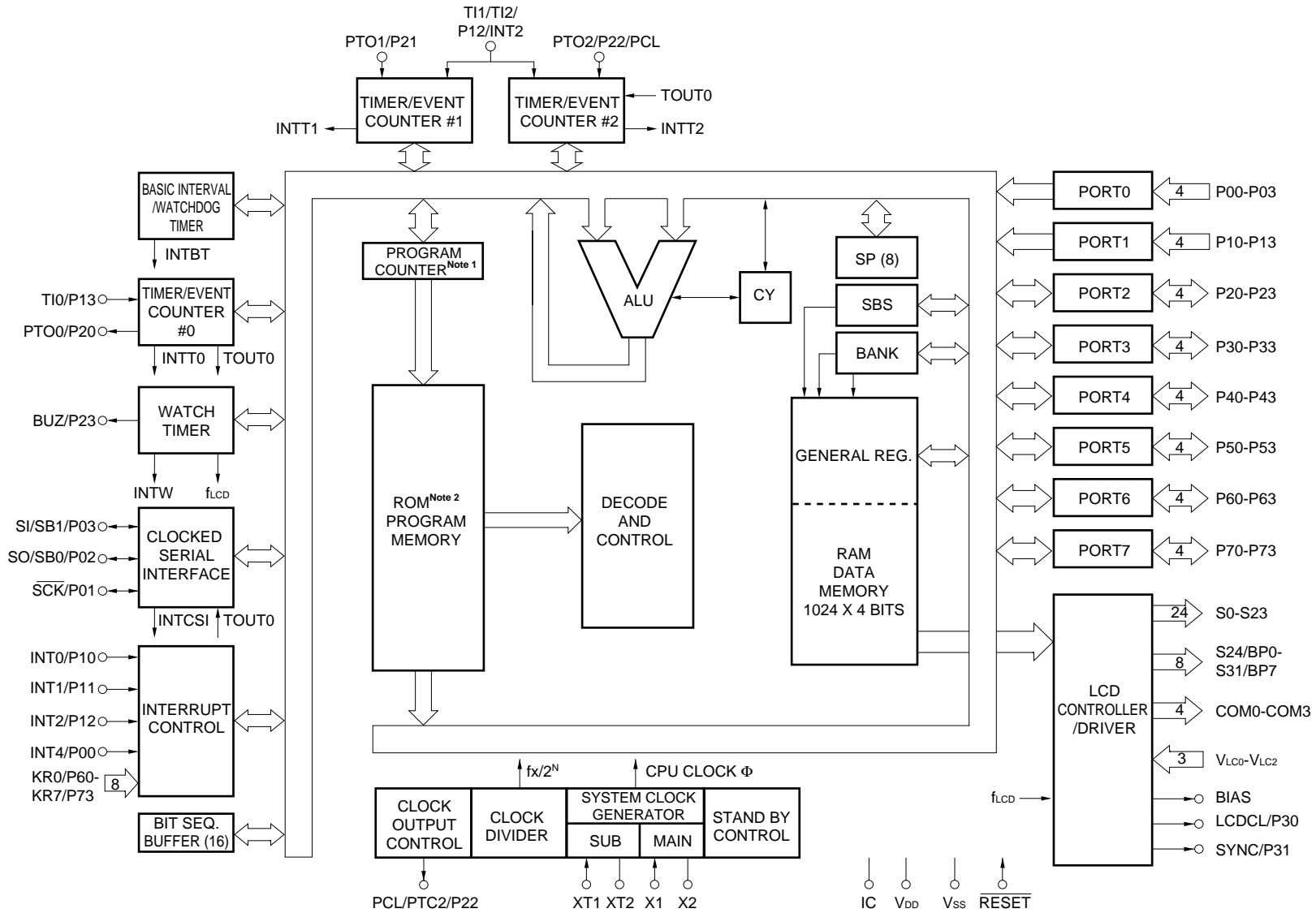

Notes 1. μPD753012 and 753016 have a 14-bit configuration, and μPD753017 has a 15-bit configuration.

2. Capacity of the ROM depends on the product.

3. PIN FUNCTION

3.1 Port Pins (1/2)

Pin Name	Input/Output	Dual Function Pin	Function	8-bit I/O	At Reset	I/O Circuit TYPE <small>Note 1</small>
P00	Input	INT4	4-bit input port (PORT0). For P01 to P03, on-chip pull-up resistors can be specified in software in 3-bit units.	×	Input	Ⓟ
P01	Input/Output	$\overline{\text{SCK}}$				Ⓣ-A
P02	Input/Output	SO/SB0				Ⓣ-B
P03	Input/Output	SI/SB1				Ⓜ-C
P10	Input	INT0	4-bit input port (PORT1). On-chip pull-up resistors can be specified in software in 4-bit units. Noise eliminator can be selected (Only P10/INT0)	×	input	Ⓟ-C
P11		INT1				
P12		TI1/TI2/INT2				
P13		TI0				
P20	Input/Output	PTO0	4-bit input/output port (PORT2). On-chip pull-up resistors can be specified in software in 4-bit units.	×	Input	E-B
P21		PTO1				
P22		PCL/PTO2				
P23		BUZ				
P30	Input/Output	LCDCL	Programmable 4-bit input/output port (PORT3). This port can be specified input/output in bit units. On-chip pull-up resistor can be specified in software in 4-bit units.	×	Input	E-B
P31		SYNC				
P32		–				
P33		–				
★ P40-P43 ^{Note 2}	Input/Output	–	N-ch open-drain 4-bit input/output port (PORT4). A pull-up resistor can be contained bit-wise (mask option). Withstand voltage is 13 V in open-drain mode.	○	High level (when pull-up resistors are contained) or high impedance	M-D
★ P50-P53 ^{Note 2}		–				

Notes 1. Circled characters indicate the Schmitt-trigger input.

2. If on-chip pull-up resistors are not specified by mask option (when used as N-ch open-drain input port), low level input leakage current increases when input or bit manipulation instruction is executed.

3.1 Port Pins (2/2)

Pin Name	Input/Output	Dual Function Pin	Function	8-bit I/O	At Reset	I/O Circuit TYPE <small>Note 1</small>
P60	Input/Output	KR0	Programmable 4-bit input/output port (PORT6). This port can be specified for input/output bit-wise. On-chip pull-up resistors can be specified in software in 4-bit units.	○	Input	ⓕ-A
P61		KR1				
P62		KR2				
P63		KR3				
P70	Input/Output	KR4	4-bit input/output port (PORT7). On-chip pull-up resistors can be specified in software in 4-bit units.		Input	ⓕ-A
P71		KR5				
P72		KR6				
P73		KR7				
★ BP0	Output	S24	1-bit output port (BIT PORT) Also used for segment output pins.	×	Note 2	H-A
BP1		S25				
BP2		S26				
BP3		S27				
BP4	Output	S28				
BP5		S29				
BP6		S30				
BP7		S31				

★ **Notes 1.** Circled characters indicate the Schmitt-trigger input.

★ **2.** For BP0 to BP7, V_{LC1} is selected as an input source.

The output levels differ depending on BP0 to BP7 and the external circuit of the V_{LC1}.

★ **Example** BP0 to BP7 are connected each other internally in the μPD753017 as shown below. Therefore, the output levels of BP0 to BP7 are determined by the levels of R₁, R₂, and R₃

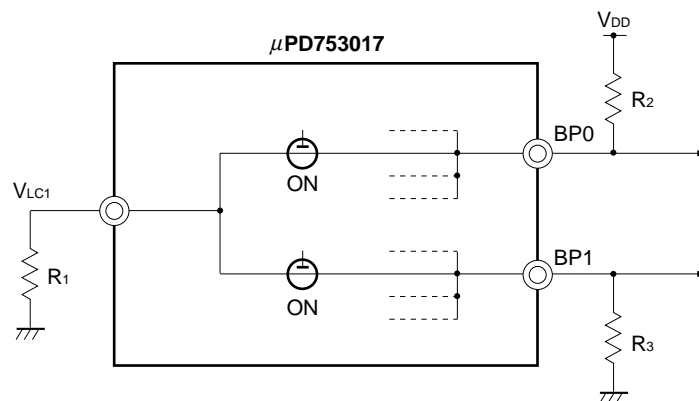

3.2 Pins Other than Port Pins (1/2)

Pin Name	Input/Output	Dual Function Pin	Function	At Reset	I/O Circuit TYPE ^{Note 1}	
TI0	Input	P13	Inputs external event pulses to the timer/event counter.	Input	ⓑ-C	
TI1		P12/INT2				
TI2						
PTO0	Output	P20	Timer/event counter output	Input	E-B	
PTO1		P21				
PTO2		P22/PCL				
PCL		P22/PTO2	Clock output			
BUZ		P23	Any frequency output (for buzzer output or system clock trimming)			
̄SCK		Input/Output	P01			Serial clock input/output
SO/SB0	P02		Serial data output Serial bus data input/output	ⓕ-B		
SI/SB1	P03		Serial data input Serial bus data input/output	Ⓜ-C		
INT4	Input	P00	Edge detection vectored interrupt input (both rising edge and falling edge detection)	Input	ⓑ	
INT0	Input	P10	Edge detection vectored interrupt input (detection edge can be selected) Noise eliminator can be selected. (Only P10/INT0)	Input	ⓑ-C	
INT1		P11	Asynchronous			
INT2	Input	P12/TI1/TI2	Edge-detection-testable input	Asynchronous	Input	ⓑ-C
KR0-KR3	Input	P60-P63	Falling edge detection testable input	Input	ⓕ-A	
KR4-KR7	Input	P70-P73	Falling edge detection testable input	Input	ⓕ-A	
S0-S23	Output	–	Segment signal output	Note 2	G-D	
S24-S31	Output	BP0-BP7	Segment signal output	Note 2	H-A	
COM0-COM3	Output	–	Common signal output	Note 2	G-B	
V _{LC0} -V _{LC2}	–	–	LCD drive power On-chip split resistor is enable (mask option).	–	–	
BIAS	Output	–	Output for external split resistor disconnect	Note 3	–	
LCDCL ^{Note 4}	Output	P30	Clock output for externally expanded driver	Input	E-B	
SYNC ^{Note 4}	Output	P31	Clock output for externally expanded driver sync	Input	E-B	
X1	Input	–	Crystal/ceramic connection pin for the main system clock oscillator. When inputting the external clock, input the external clock to pin X1, and the reverse phase of the external clock to pin X2.	–	–	
X2	–					

- Notes**
1. Circled characters indicate the Schmitt trigger input.
 2. Each displays output selects the following V_{LCx} as input source.
S0-S31: V_{LC1}, COM0-COM2: V_{LC2}, COM3: V_{LC0}.
 3. When a split resistor is contained Low level
When no split resistor is contained High impedance
 4. These pins are provided for future system expansion. At present, these pins are used only as pins P30 and P31.

3.2 Pins Other than Port Pins (2/2)

Pin Name	Input/Output	Dual Function Pin	Function	At Reset	I/O Circuit TYPE ^{Note}
XT1	Input	-	Crystal connection pin for the subsystem clock oscillator. When the external clock is used, input the external clock to pin XT1. In this case, pin XT2 must be left unconnected. Pin XT1 can be used as a 1-bit input (test) pin.	-	-
XT2	-				
$\overline{\text{RESET}}$	Input	-	System reset input (low level active)	-	Ⓑ
IC	-	-	Internally connected. Connect directly to V _{DD} .	-	-
V _{DD}	-	-	Positive power supply	-	-
V _{SS}	-	-	GND	-	-

Note Circled characters indicate the Schmitt trigger input.

3.3 Pin Input/Output Circuits

The μPD753017 pin input/output circuits are shown schematically.

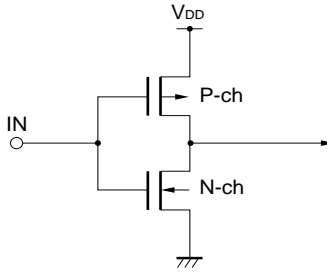
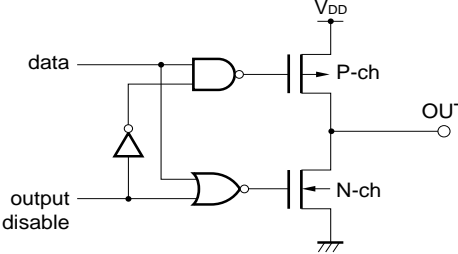
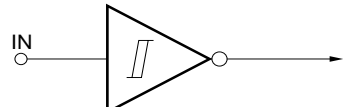
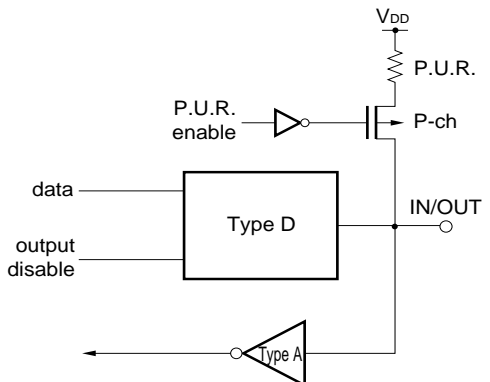
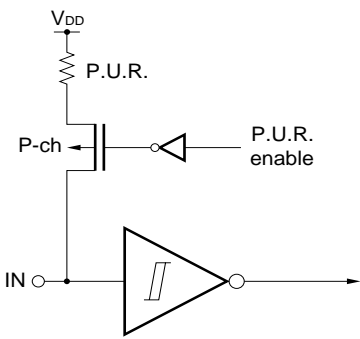
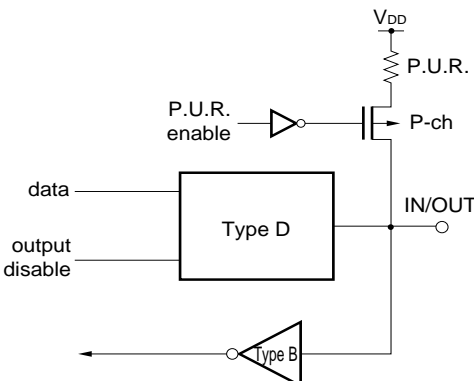
<p>TYPE A</p>  <p>CMOS specification input buffer.</p>	<p>TYPE D</p>  <p>Push-pull output that can be placed in output high impedance (both P-ch, N-ch off).</p>
<p>TYPE B</p>  <p>Schmitt trigger input having hysteresis characteristic.</p>	<p>TYPE E-B</p>  <p>P.U.R. : Pull-Up Resistor</p>
<p>TYPE B-C</p>  <p>P.U.R. : Pull-Up Resistor</p>	<p>TYPE F-A</p>  <p>P.U.R. : Pull-Up Resistor</p>

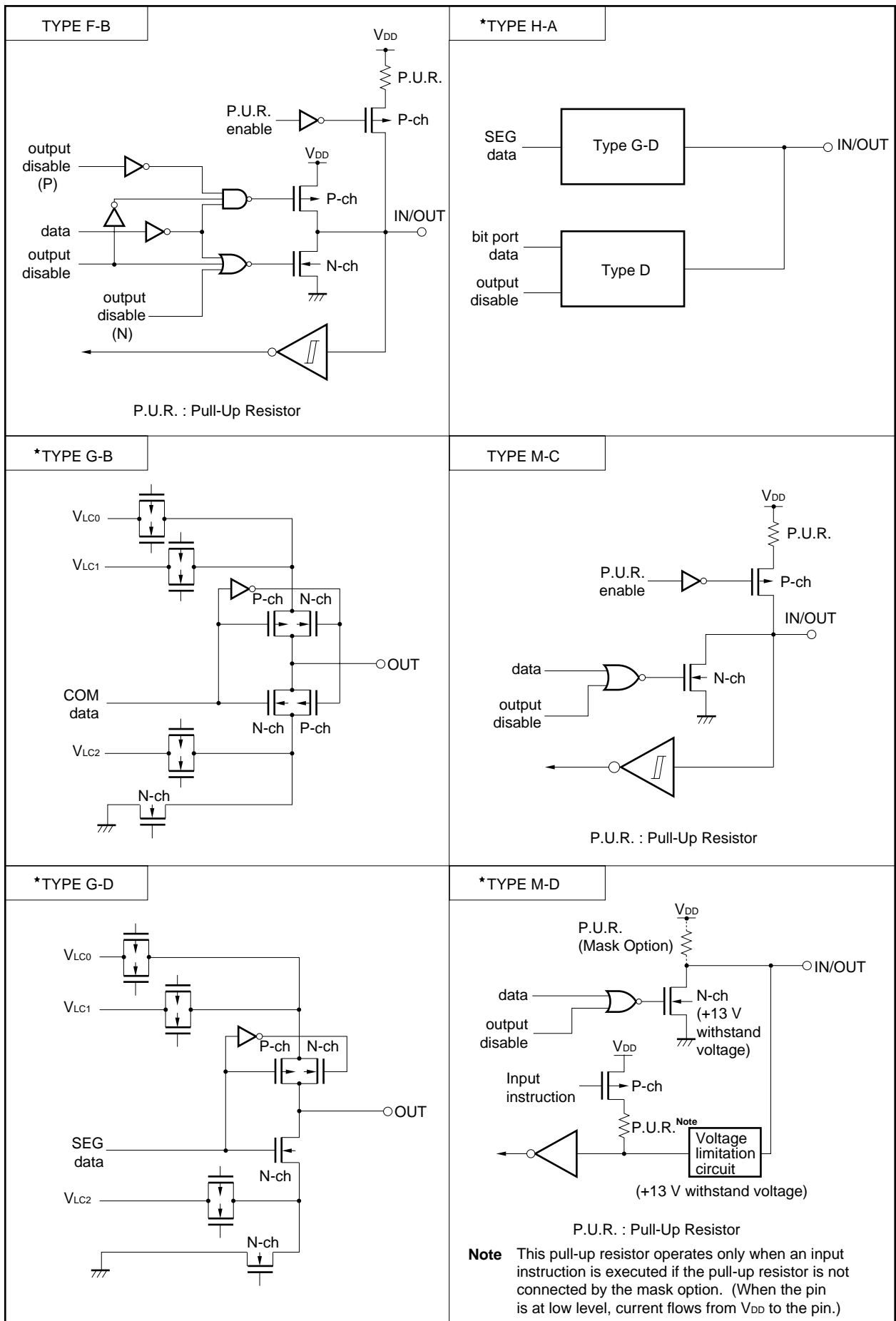

3.4 Recommended Connection for Unused Pins

★

Table 3-1. List of Recommended Connection for Unused Pins

Pin	Recommended Connection	
P00/INT4	Connect to V _{SS} or V _{DD} .	
P01/ $\overline{\text{SCK}}$	Independently connect to V _{SS} or V _{DD} via resistor.	
P02/SO/SB0		
P03/SI/SB1	Connected to V _{SS} .	
P10/INT0, P11/INT1	Connect to V _{SS} or V _{DD} .	
P12/TI1/TI2/INT2		
P13/TI0		
P20/PTO0	Input state : Individually connect to V _{SS} or V _{DD} via resistor.	
P21/PTO1		
P22/PTO2/PCL	Output state: Leave unconnected.	
P23/BUZ		
P30/LCDCL		
P31/SYNC		
P32		
P33		
P40-P43		Input state : Connect to V _{SS} .
P50-P53		Output state: Connected to V _{SS} . (Do not connect the pull-up resistor by mask option).
P60/KR0-P63/KR3	Input state : Individually connected to V _{SS} or V _{DD} via resistor.	
P70/KR4-P73/KR7		
S0-S23	Leave unconnected.	
S24/BP0-S31/BP7		
COM0-COM3		
V _{LC0} -V _{LC2}	Connect to V _{SS} .	
BIAS	Only if all of V _{LC0} -V _{LC2} are unused, connect to V _{SS} . In other cases, leave unconnected.	
XT1	Connect to V _{SS} .	
XT2	Leave unconnected.	
IC	Directly connect to V _{DD} .	

4. SWITCHING FUNCTION BETWEEN MK I MODE AND MK II MODE

4.1 Differences between Mk I Mode and Mk II Mode

The CPU of μPD753017 has the following two modes: Mk I and Mk II, either of which can be selected. The mode can be switched by the bit 3 of the stack bank select register (SBS).

- Mk I mode: Upward compatible with μPD75316B.
Can be used in the 75XL CPU with a ROM capacity of up to 16K bytes.
- Mk II mode: Incompatible with μPD75316B.
Can be used in all the 75XL CPU's including those products whose ROM capacity is more than 16K bytes.

Table 4-1. Differences between Mk I Mode and Mk II Mode

	Mk I Mode	Mk II Mode
Program memory (bytes)	<ul style="list-style-type: none"> • μPD753012 : 12288 • μPD753016, 753017 : 16384 	<ul style="list-style-type: none"> • μPD753012 : 12288 • μPD753016 : 16384 • μPD753017 : 24576
Number of stack bytes for subroutine instructions	2 bytes	3 bytes
BRA !addr1 instruction CALLA !addr1 instruction	Not available	Available
CALL !addr instruction	3-machine cycles	4-machine cycles
CALLF !faddr instruction	2-machine cycles	3-machine cycles

★ **Caution** The Mk II mode supports a program area which exceeds 16K bytes in the 75X and 75XL series. This mode enhances the software compatibility with products which have more than 16K bytes.

When Mk II mode is selected, the number of stack bytes (usable area) in the execution of a subroutine call instruction increases by 1 per stack compared to Mk I mode. Furthermore, when a CALL !addr, or CALLF !faddr instruction is used, each instruction takes another machine cycle. Therefore, when more importance is attached to RAM utilization or throughput than software compatibility, use the Mk I mode.

4.2 Setting Method of Stack Bank Select Register (SBS)

Switching between the Mk I mode and Mk II mode can be done by the SBS. Figure 4-1 shows the format.

The SBS is set by a 4-bit memory manipulation instruction. When using the Mk I mode, the SBS must be initialized to 10XXB^{Note} at the beginning of a program. When using the Mk II mode, it must be initialized to 00XXB^{Note}.

Figure 4-1. Stack Bank Select Register Format

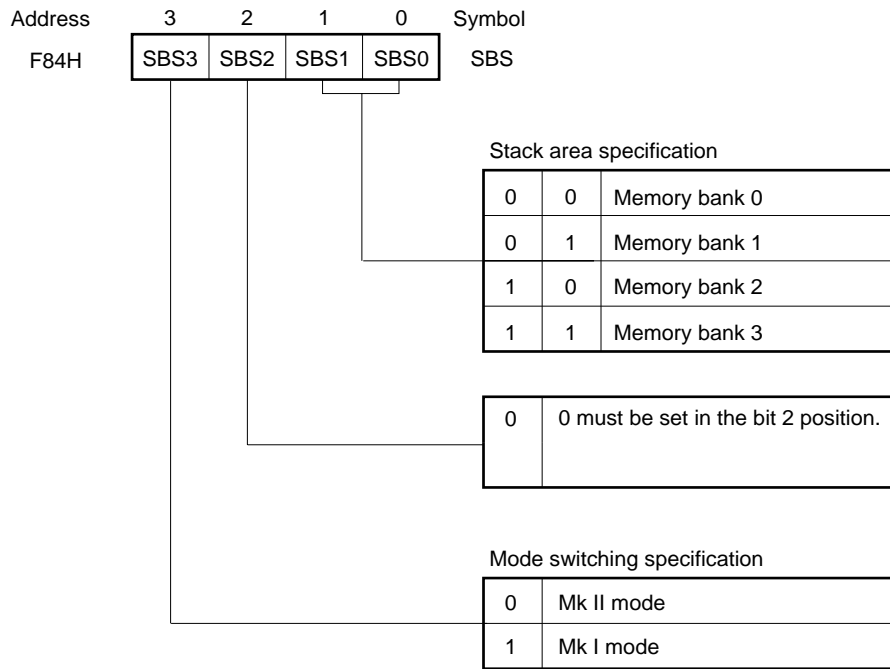

Note The desired numbers must be set in the XX positions.

Caution Since SBS. 3 is set to “1” after a $\overline{\text{RESET}}$ signal is generated, the CPU operates in the Mk I mode. When executing an instruction in the Mk II mode, set SBS. 3 to “0” to select the Mk II mode.

5. MEMORY CONFIGURATION

- Program memory (ROM) 12288 × 8 bits (μPD753012)
 16384 × 8 bits (μPD753016)
 24576 × 8 bits (μPD753017)
- Data memory (RAM)
 - Data area ...1024 words × 4 bits (000H to 3FFH)
 - Peripheral hardware area...128 × 4 bits (F80H to FFFH)

Figure 5-1. Program Memory Map (1/3)

(a) μPD753012

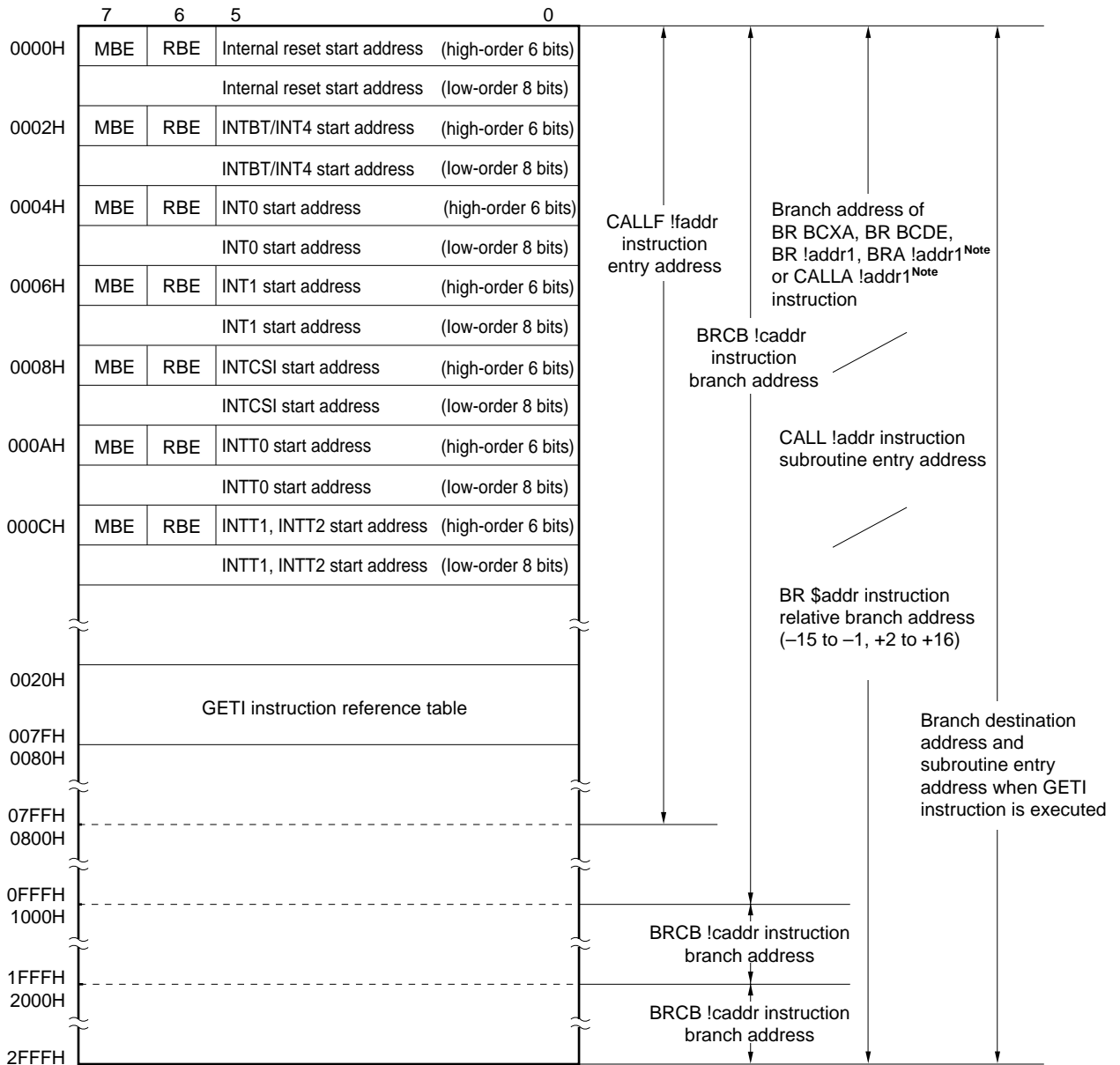

★ **Note** Can be used in Mk II mode only.

Remark In addition to the above, a branch can be taken to the address indicated by changing only the low-order eight bits of PC by executing the BR PCDE, BR PCXA instruction.

Figure 5-1. Program Memory Map (2/3)

(b) μPD753016

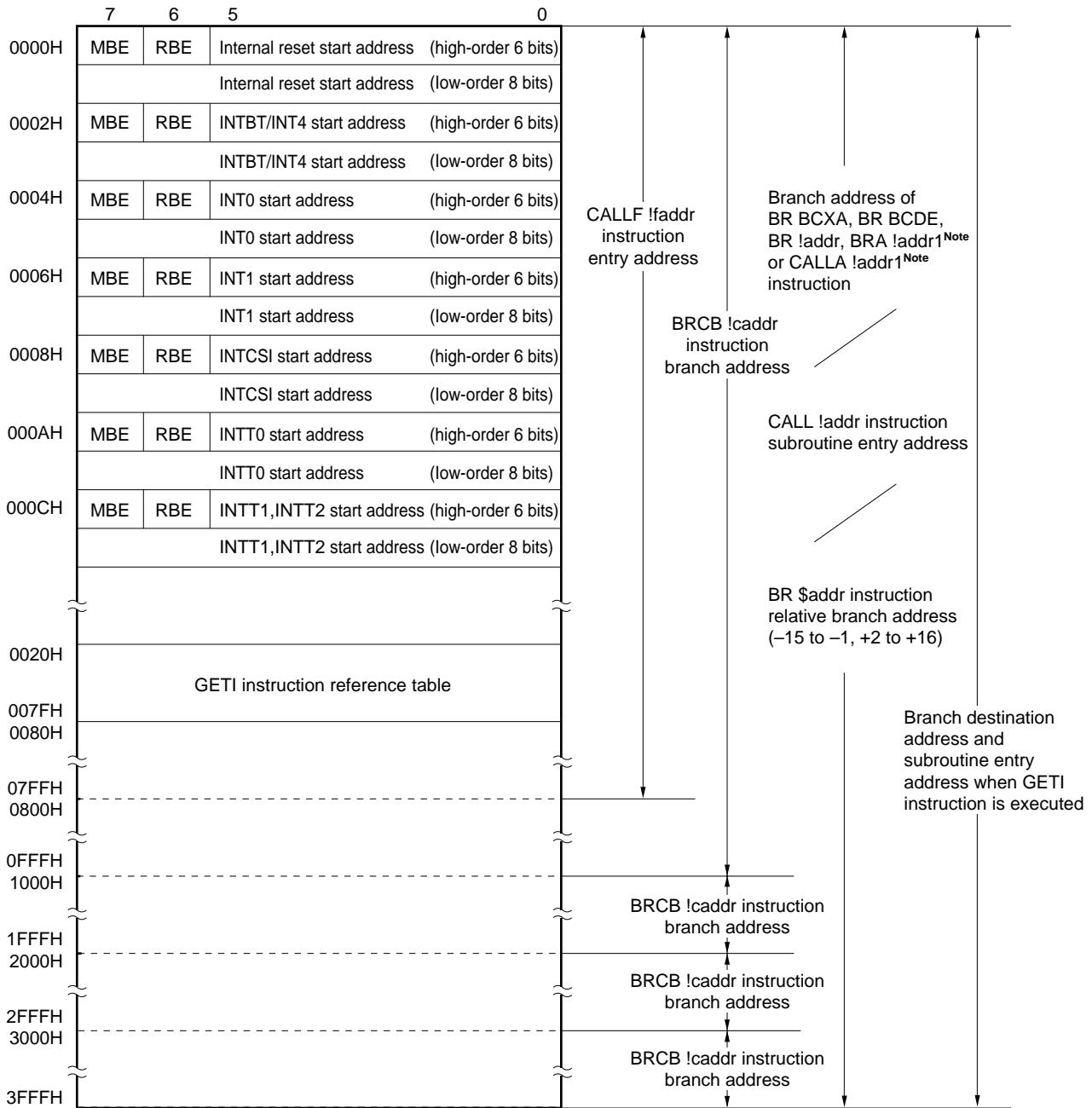

★ **Note** Can be used in Mk II mode only.

Remark In addition to the above, a branch can be taken to the address indicated by changing only the low-order eight bits of PC by executing the BR PCDE, BR PCXA instruction.

Figure 5-1. Program Memory Map (3/3)

(c) μPD753017

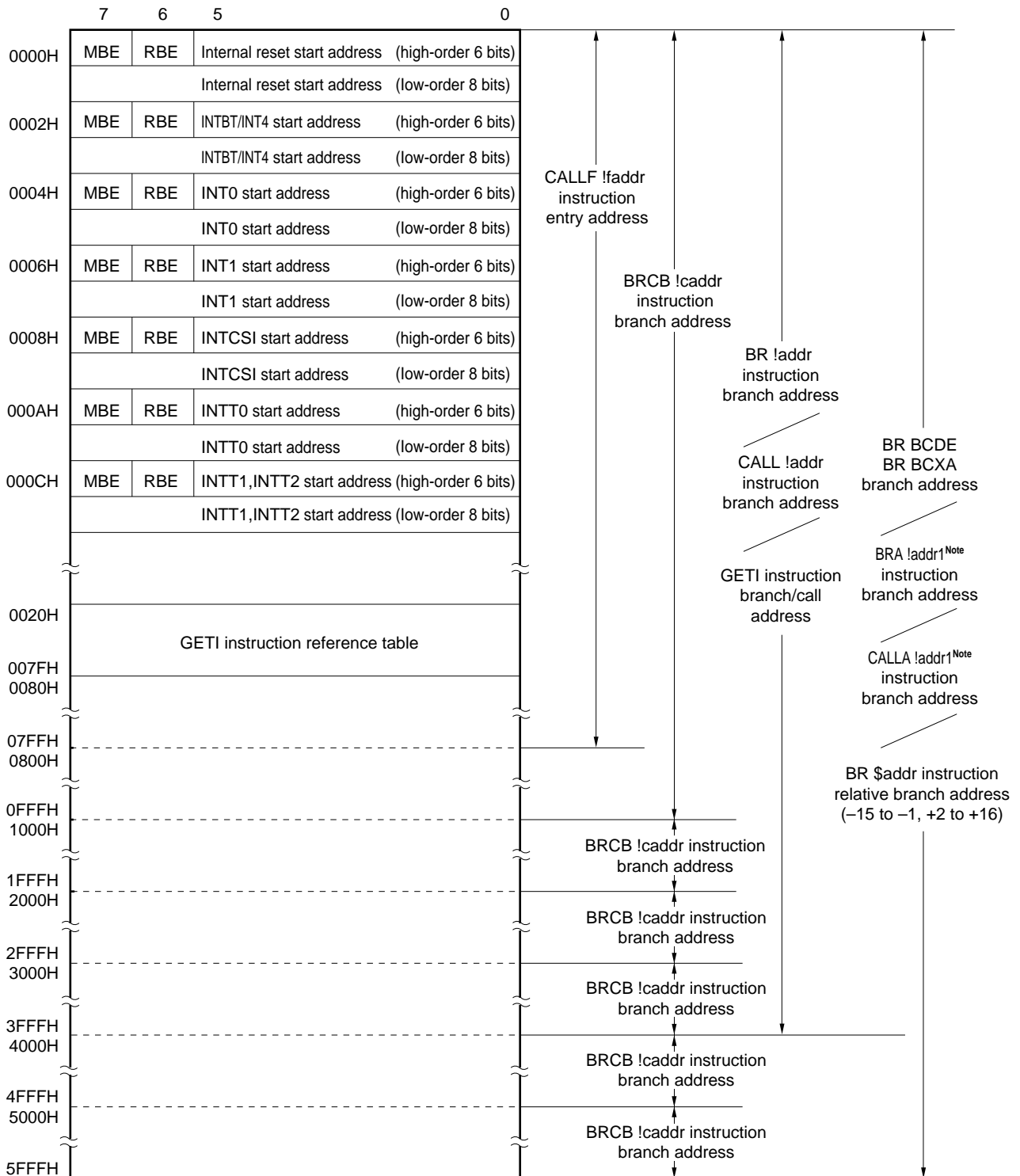

★ **Note** Can be used in Mk II mode only.

Caution The interrupt vector start address shown above consists of 14 bits. Set it in 16K space (0000H-3FFFH).

Remark In addition to the above, a branch can be taken to the address indicated by changing only the low-order eight bits of PC by executing the BR PCDE, BR PCXA instruction.

Figure 5-2. Data Memory Map

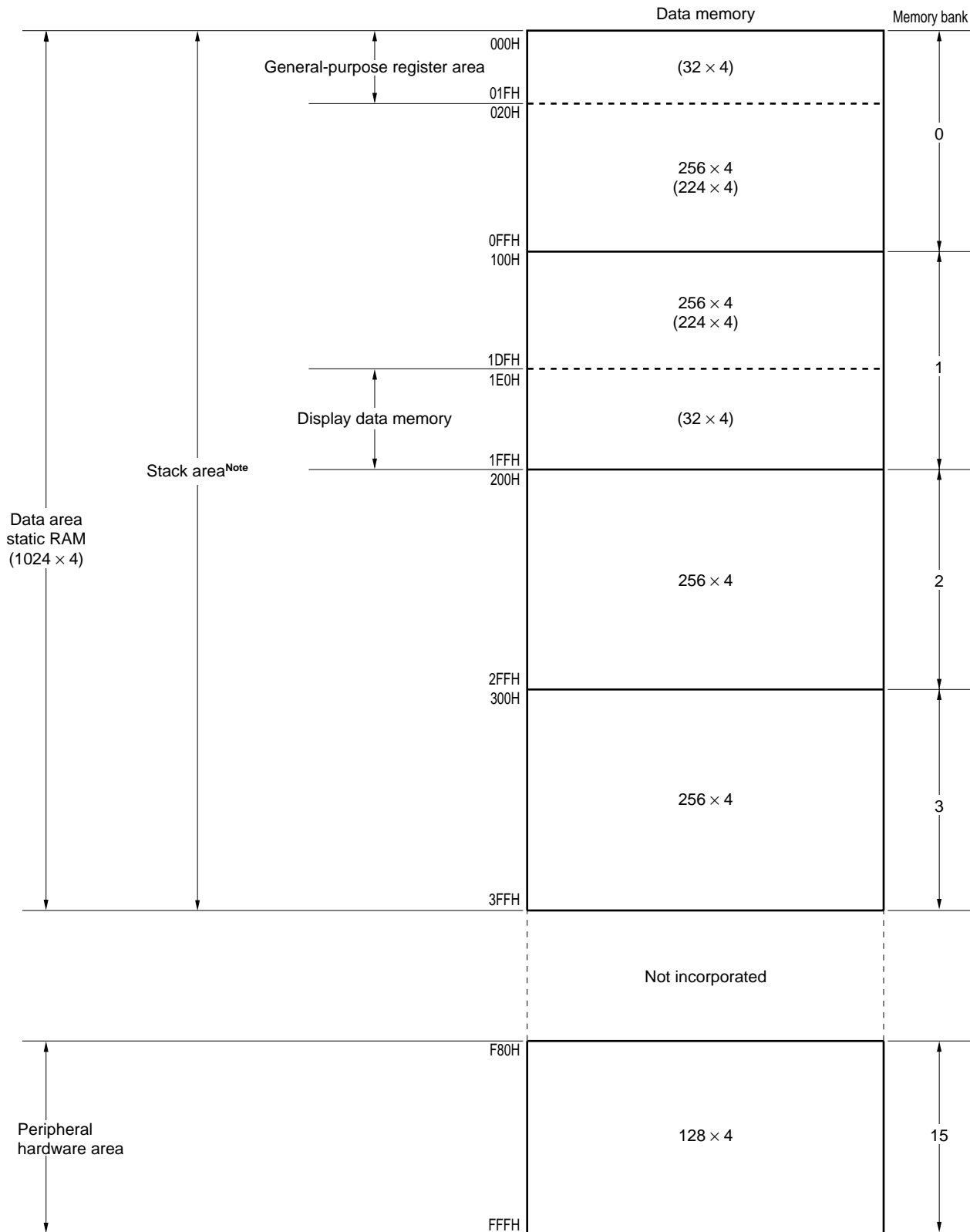

Note For stack area, one memory bank can be selected among memory bank 0-3.

6. PERIPHERAL HARDWARE FUNCTIONS

6.1 Digital Input/Output Ports

There are four types of I/O ports as follows.

· CMOS input (PORT0, 1)	: 8
· CMOS input/output (PORT2, 3, 6, 7)	: 16
· N-channel open-drain input/output (PORT4, 5)	: 8
· Bit port output (BP0-BP7)	: 8
Total	40

Table 6-1. Types and Features of Digital Ports

Port (Pin Name)	Function	Operation & Features		Remarks
PORT0 (P00-P03)	4-bit input	Dual function pins also function as output pins depending on the operation mode when the serial interface function is used.		Also used for the INT4, SCK, SO/SB0, SI/SB1 pins.
PORT1 (P10-P13)		Dedicated 4-bit I/O port		Also used for the INT0-INT2 and T10-T12 pins.
PORT2 (P20-P23)	4-bit I/O	Can be set to input mode or output mode in 4-bit units.		Also used for the PTO0-PTO2, PCL, BUZ pins.
PORT3 (P30-P33)		Can be set to input mode or output mode in 1/4 bit units.		Also used for the LCDCL, SYNC pins.
PORT4 (P40-P43)	4-bit I/O (N-channel open-drain, 13 V withstanding)	Can be set to input mode or output mode in 4-bit units.	Ports 4 and 5 are paired and data can be input/output in 8-bit units.	On-chip pull-up resistor can be specified bit-wise by mask option.
PORT5 (P50-P53)				
PORT6 (P60-P63)	4-bit I/O	Can be set to input mode or output mode in 1/4-bit units.	Ports 6 and 7 are paired and data can be input/output in 8-bit units.	Also used for the KR0-KR3 pins.
PORT7 (P70-P73)		Can be set to input mode or output mode in 4-bit units.		Also used for the KR4-KR7 pins.
BP0-BP7	1-bit output	Outputs data bit-wise. Can be switched to LCD drive segment output S24-S31 by software.		—

★

6.2 Clock Generator

Operation of the clock generator is determined by the processor clock control register (PCC) and system clock control register (SCC).

The two clocks, the main system clock and subsystem clock, are available.

The instruction execution time can be altered.

- 0.95 μs, 1.91 μs, 3.81 μs, 15.3 μs (main system clock : at 4.19 MHz operation)
- 0.67 μs, 1.33 μs, 2.67 μs, 10.7 μs (main system clock : at 6.0 MHz operation)
- 122 μs (subsystem clock : at 32.768 kHz operation)

Figure 6-1. Clock Generator Block Diagram

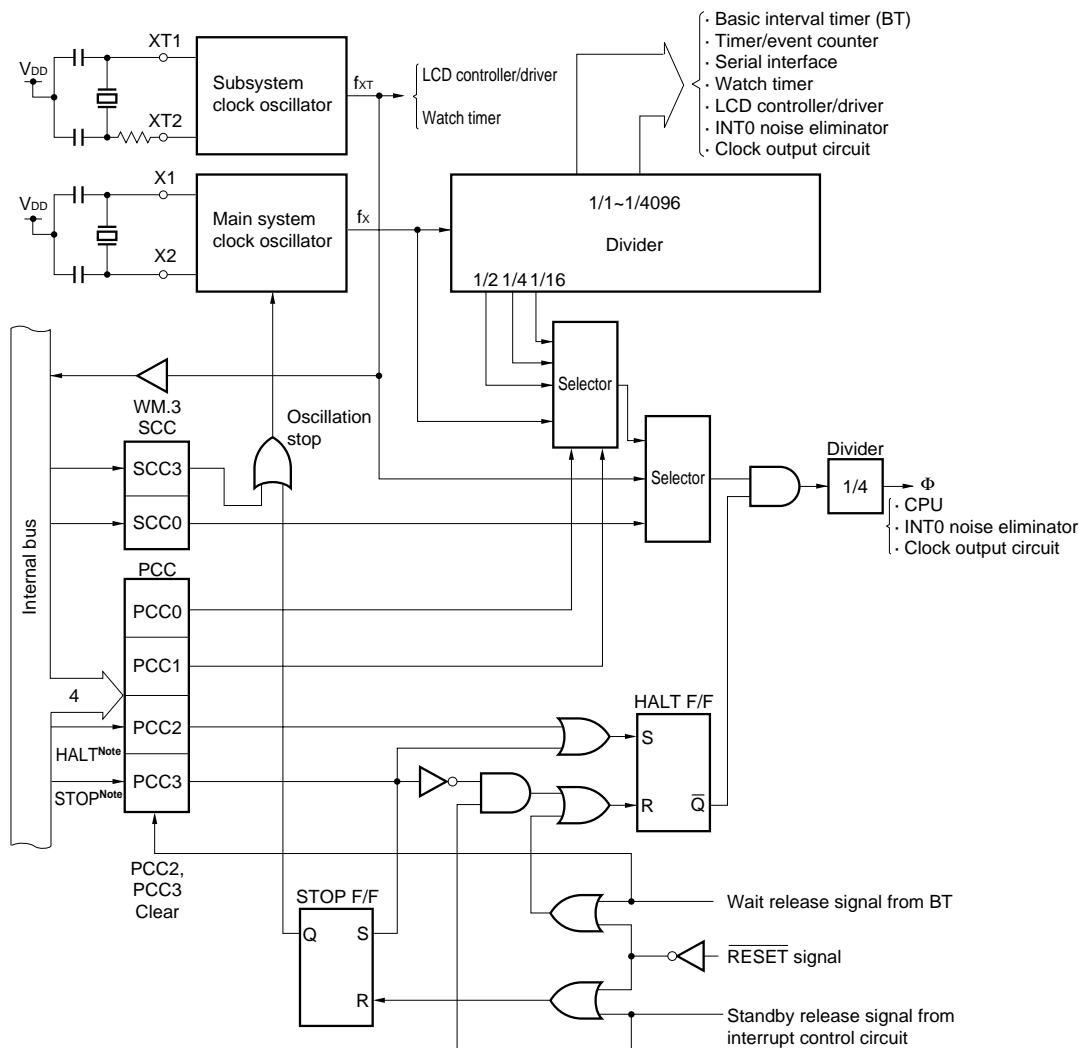

Note Instruction execution

- Remarks**
1. f_x = Main system clock frequency
 2. f_{XT} = Subsystem clock frequency
 3. Φ = CPU clock
 4. PCC: Processor Clock Control Register
 5. SCC: System Clock Control Register
 6. One clock cycle (t_{CY}) of Φ equal to one machine cycle of the instruction.

6.3 Subsystem Clock Oscillator Control Functions

The μPD753017 subsystem clock oscillator has the following two control functions.

- Selects by software whether an on-chip feedback resistor is to be used or not^{Note}.
- Reduces current consumption by decreasing the drive current of the on-chip inverter when the supply current is high ($V_{DD} \geq 2.7$ V).

★ **Note** When not using the subsystem clock, set SOS.0 to 1 in software (on-chip feedback resistor is not used), connect XT1 to V_{SS} , and leave XT2 unconnected, so that the current consumption of the subsystem clock oscillator can be reduced.

The above functions can be used by switching the bits 0 and 1 of the sub-oscillator control register (SOS). (Refer to **Figure 6-2.**)

★

Figure 6-2. Subsystem Clock Oscillator

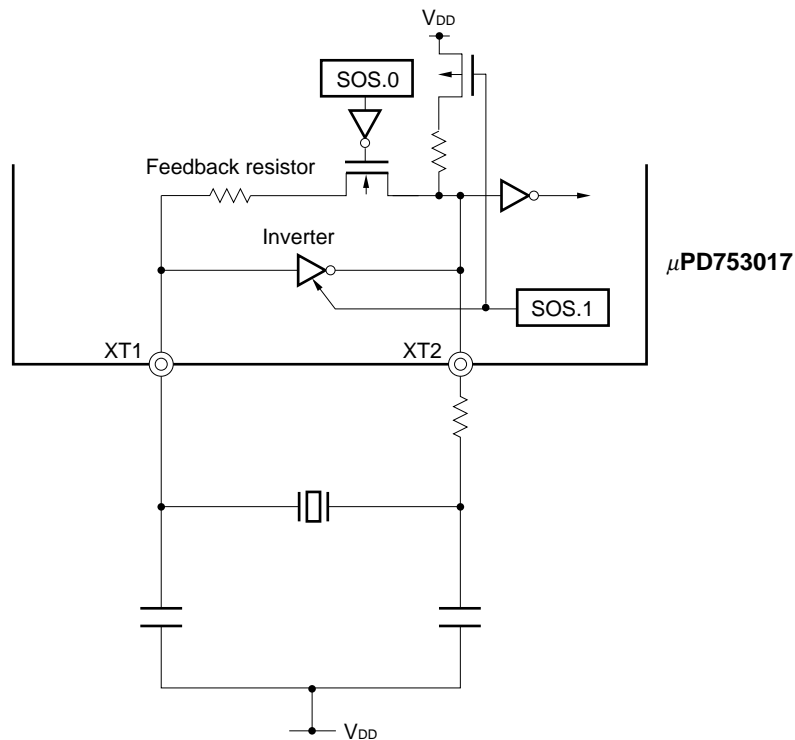

6.4 Clock Output Circuit

The clock output circuit is provided to output the clock pulses from the P22, PTO2, and PCL pins to the remote control waveform outputs and peripheral LSI's, etc.

- Clock output (PCL) : Φ , 524, 262, 65.5 kHz (at 4.19 MHz operation)
 Φ , 750, 375, 93.8 kHz (at 6.0 MHz operation)

Figure 6-3. Clock Output Circuit Block Diagram

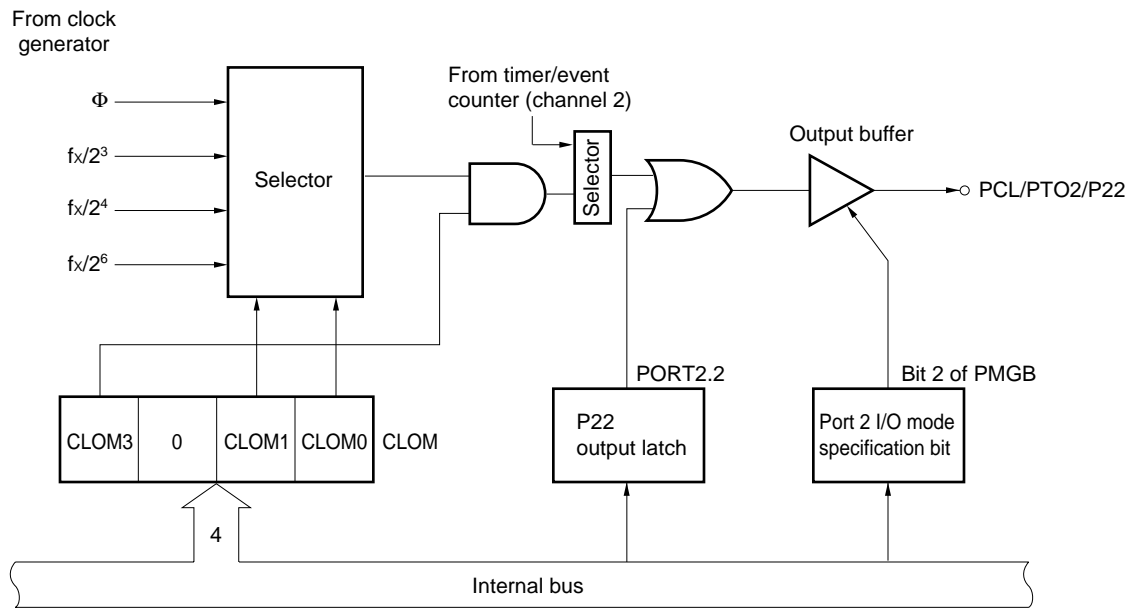

Remark Special care has been taken in designing the chip so that small-width pulses may not be output when switching clock output enable/disable.

6.5 Basic Interval Timer/Watchdog Timer

The basic interval timer/watchdog timer has the following functions.

- Interval timer operation to generate a reference time interrupt
- Watchdog timer operation to detect a runaway of program and reset the CPU
- Selects and counts the wait time when the standby mode is released
- Reads the contents of counting

Figure 6-4. Basic Interval Timer/Watchdog Timer Block Diagram

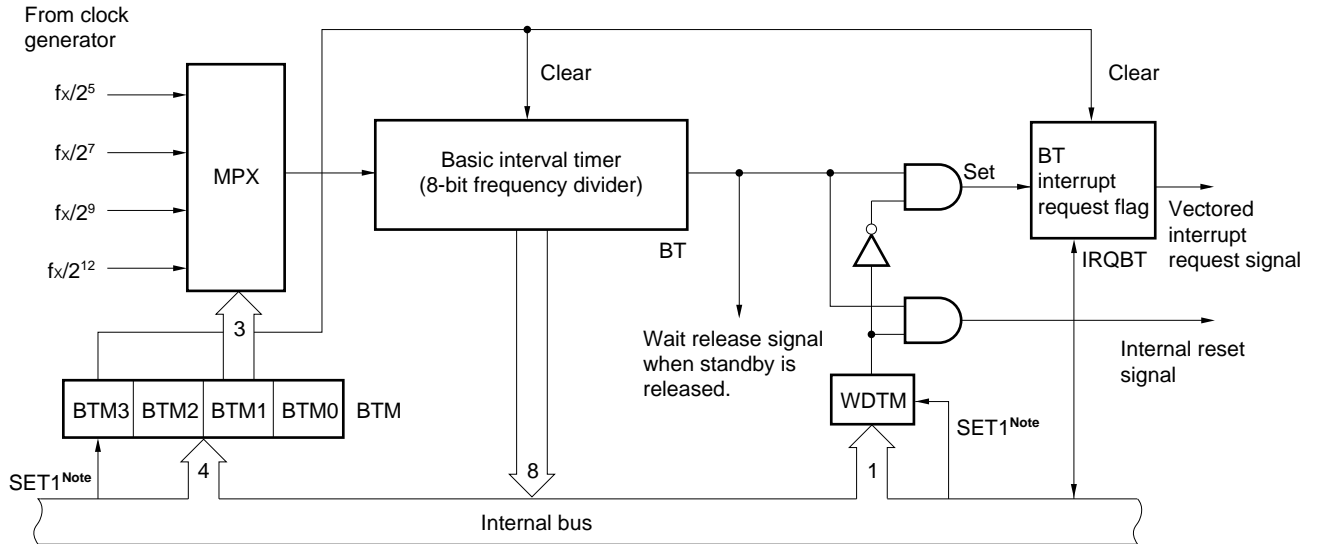

Note Instruction execution

6.6 Watch Timer

The μPD753017 has one channel of watch timer. The watch timer has the following functions.

- Sets the test flag (IRQW) with 0.5 sec interval.
The standby mode can be released by the IRQW.
- 0.5 sec interval can be created by both the main system clock and subsystem clock. Take $f_x = 4.194304$ MHz for the main system clock frequency and $f_{XT} = 32.768$ kHz for the subsystem clock.
- Convenient for program debugging and checking as interval becomes 128 times longer (3.91 ms) with the fast feed mode.
- Outputs the frequencies (2.048, 4.096, 32.768 kHz) to the P23 and BUZ pins, usable for buzzer and trimming of system clock frequencies.
- Clears the frequency divider to make the clock start with zero seconds.

Figure 6-5. Watch Timer Block Diagram

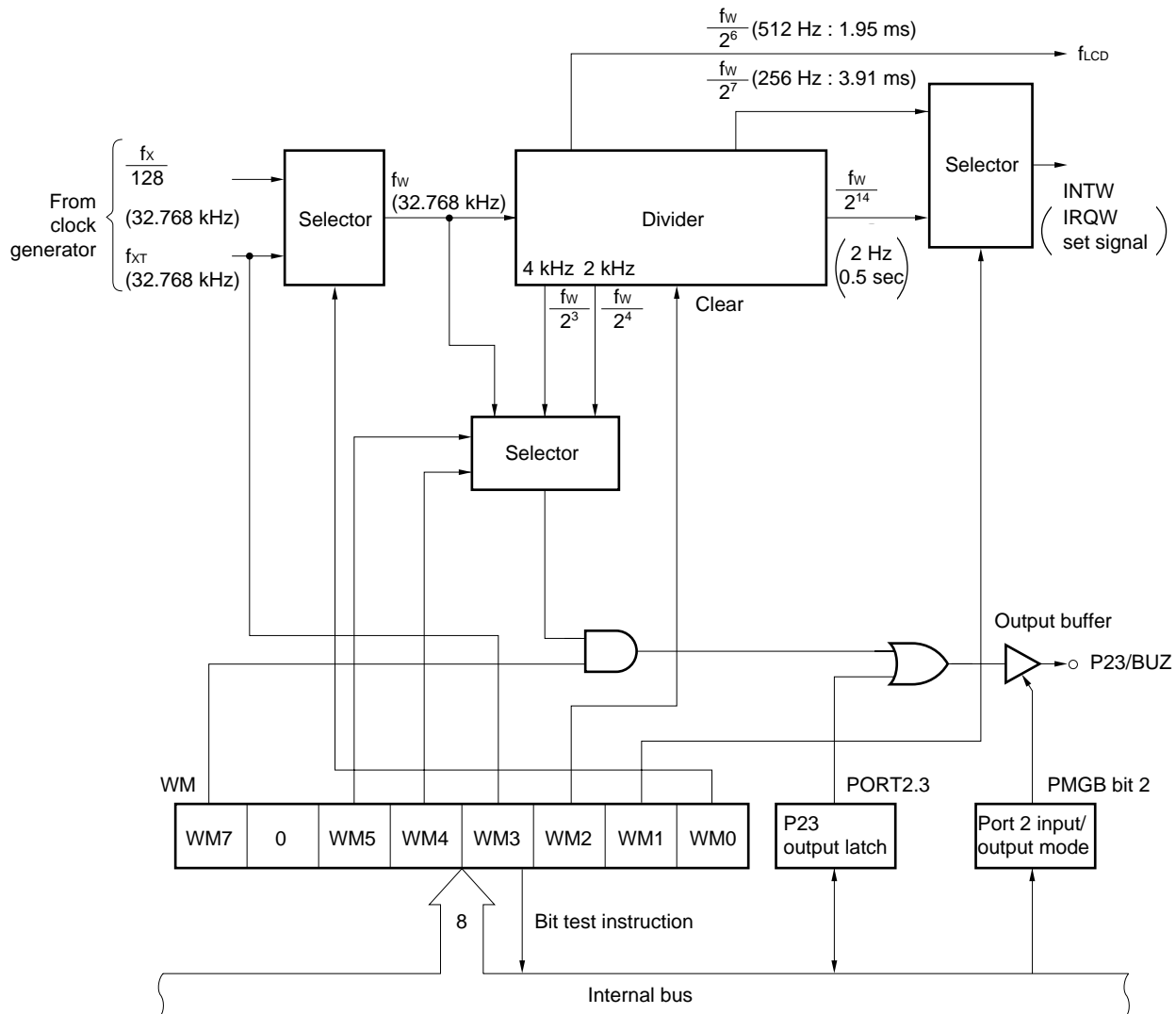

The values enclosed in parentheses are applied when $f_x = 4.194304$ MHz and $f_{XT} = 32.768$ kHz.

6.7 Timer/Event Counter

The μPD753017 has three channels of timer/event counter. The timer/event counter has the following functions.

- Programmable interval timer operation
- Square wave output of any frequency to the PTO_n pin
- Event counter operation
- Divides the frequency of signal input via the TIn pin to 1-Nth of the original signal and outputs the divided frequency to the PTO_n pin (frequency divider operation).
- Supplies the serial shift clock to the serial interface circuit.
- Calls the counting status.

The timer/event counter operates in the following four modes as set by the mode register.

Table 6-2. Operation Modes of Timer/Event Counter

Mode	Channel		
	Channel 0	Channel 1	Channel 2
8-bit timer/event counter mode	○	○	○
Gate control function	× Note	×	○
PWM pulse generator mode	×	×	○
16-bit timer/event counter mode	×	○	
Gate control function	× Note	○	
Carrier generator mode	×	○	

Note Used for gate control signal generation

Figure 6-7. Timer/Event Counter Block Diagram (channel 1)

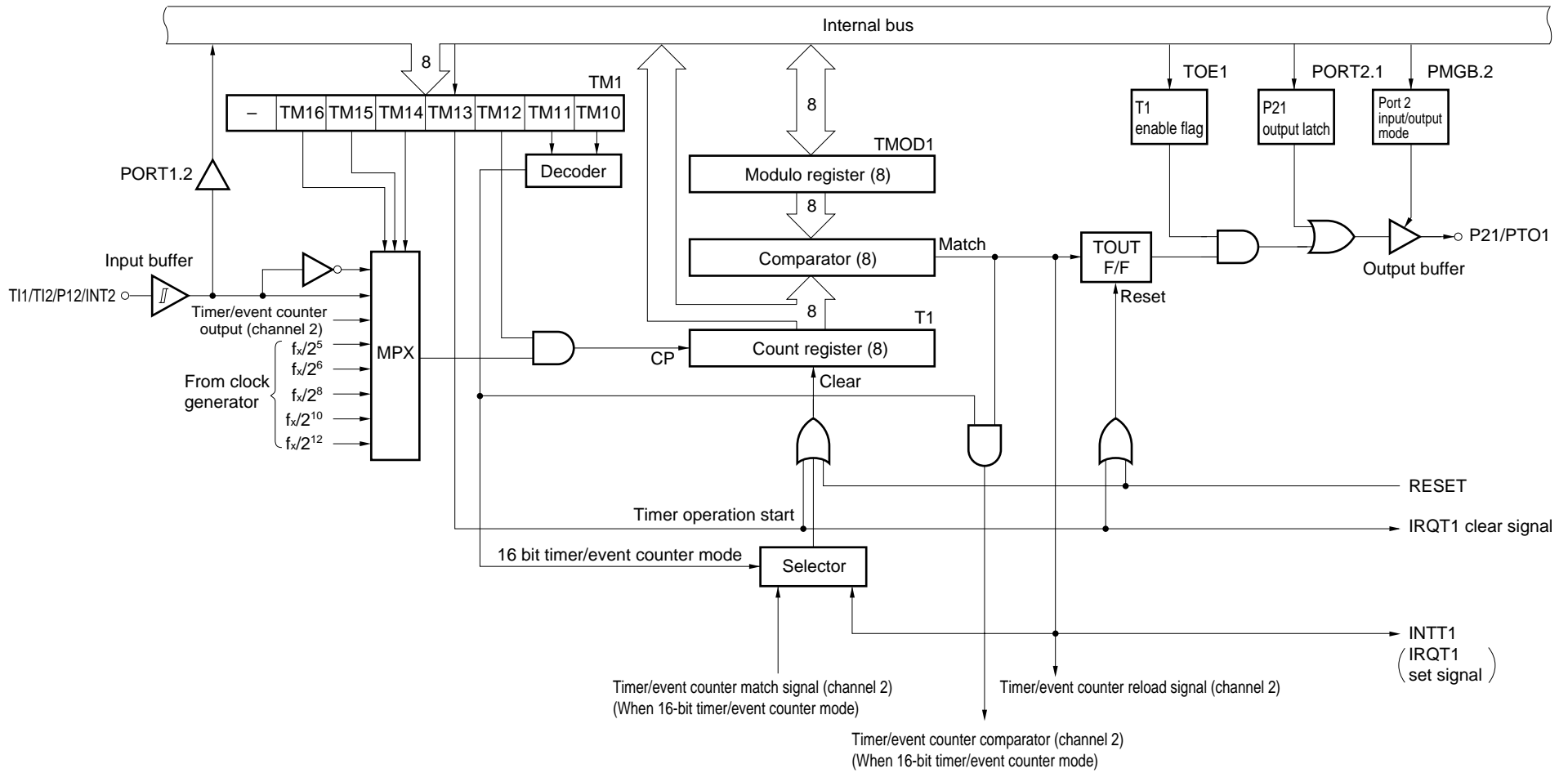
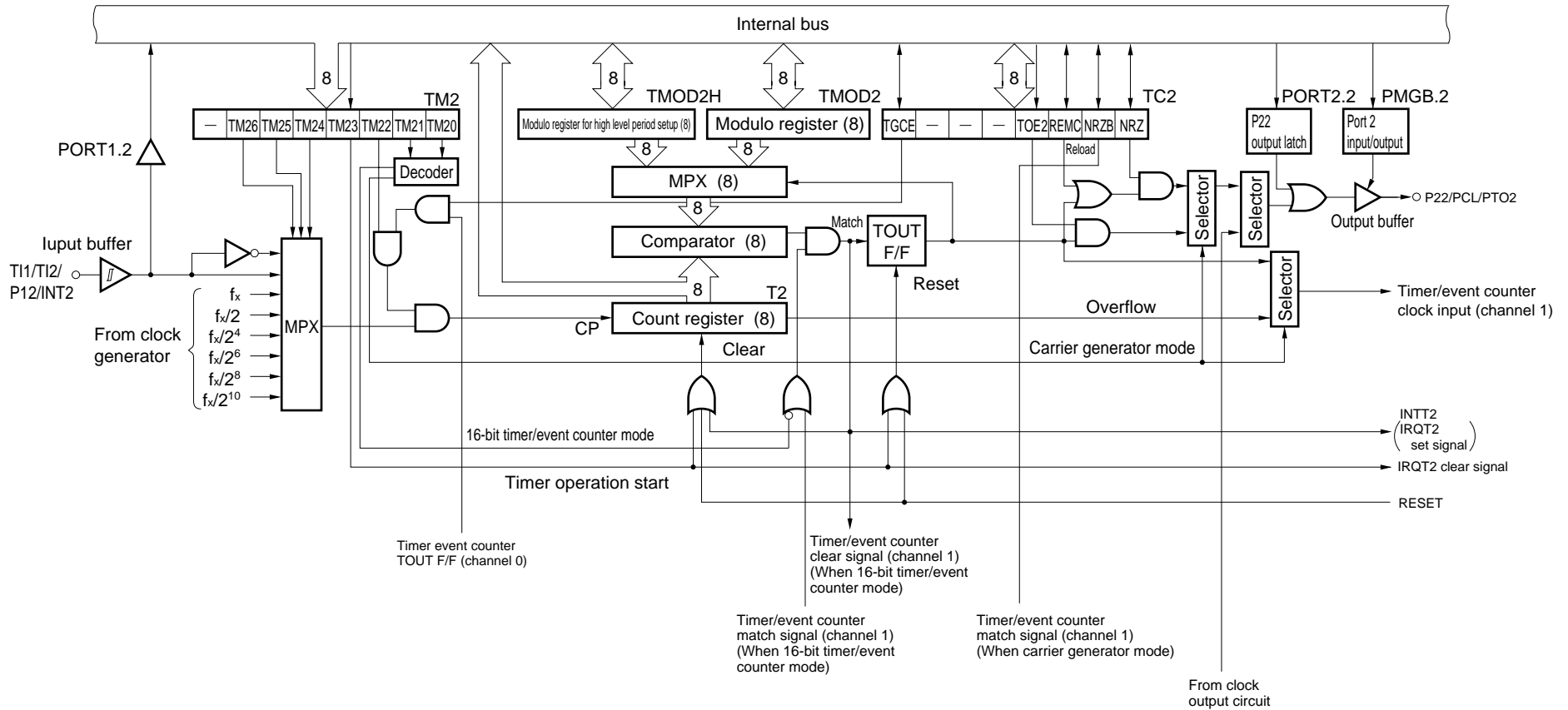

Figure 6-8. Timer/Event Counter Block Diagram (channel 2)



6.8 Serial Interface

The μ PD753017 is provided with an 8-bit clocked serial interface. This serial interface operates in the following four modes:

- Operation stop mode
- 3-wire serial I/O mode
- 2-wire serial I/O mode
- SBI mode

Figure 6-9. Serial Interface Block Diagram

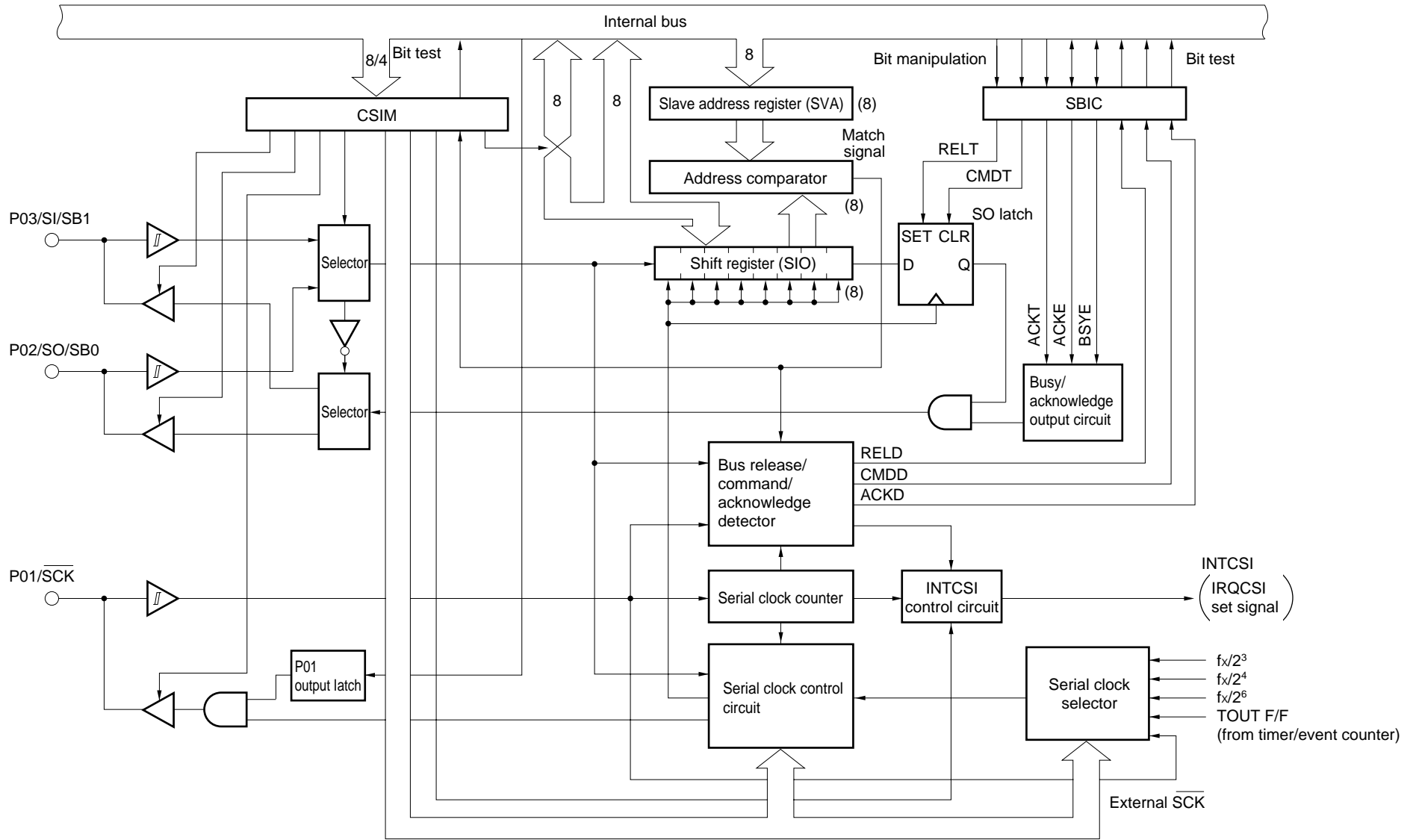

6.9 LCD Controller/Driver

The μ PD753017 incorporates a display controller which generates segment and common signals according to the display data memory contents and incorporates segment and common drivers which can drive the LCD panel directly.

The μ PD753017 LCD controller/driver functions are as follows:

- Display data memory is read automatically by DMA operation and segment and common signals are generated.
- Display mode can be selected from among the following five:
 - <1> Static
 - <2> 1/2 duty (time multiplexing by 2), 1/2 bias
 - <3> 1/3 duty (time multiplexing by 3), 1/2 bias
 - <4> 1/3 duty (time multiplexing by 3), 1/3 bias
 - <5> 1/4 duty (time multiplexing by 4), 1/3 bias
- A frame frequency can be selected from among four in each display mode.
- A maximum of 32 segment signal output pins (S0-S31) and four common signal output pins (COM0-COM3).
- The segment signal output pins (S24-S27 and S28-S31) can be changed to the output ports in 4-pin units.
- Split-resistor can be incorporated to supply LCD drive power. (Mask option)
 - Various bias methods and LCD drive voltages can be applicable.
 - When display is off, current flow to the split resistor is cut.
- Display data memory not used for display can be used for normal data memory.
- It can also operate by using the subsystem clock.

Figure 6-10. LCD Controller/Driver Block Diagram

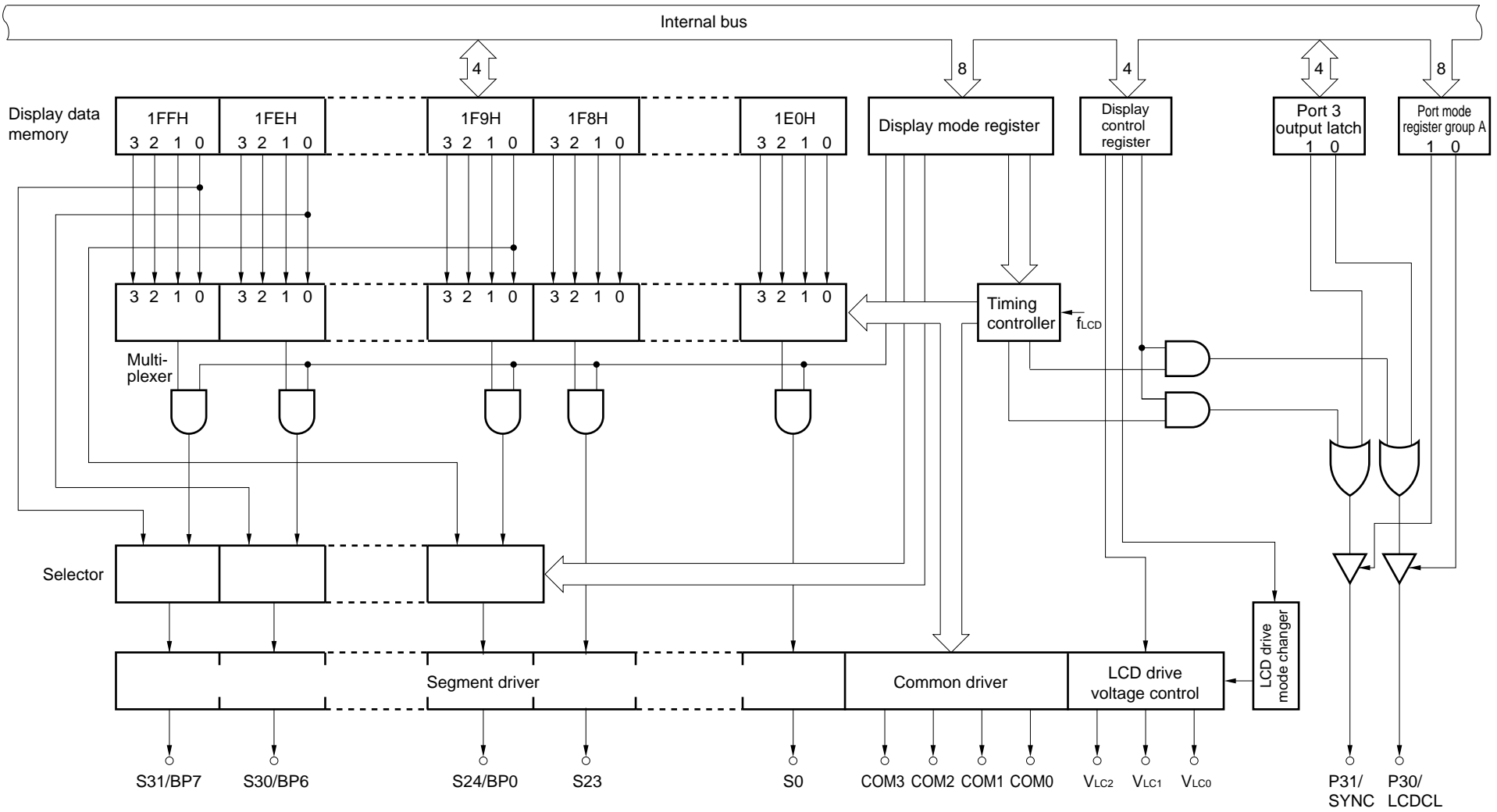

6.10 Bit Sequential Buffer ... 16 Bits

The bit sequential buffer (BSB) is a special data memory for bit manipulation and the bit manipulation can be easily performed by changing the address specification and bit specification in sequence, therefore it is useful when processing a long data bit-wise.

Figure 6-11. Bit Sequential Buffer Format

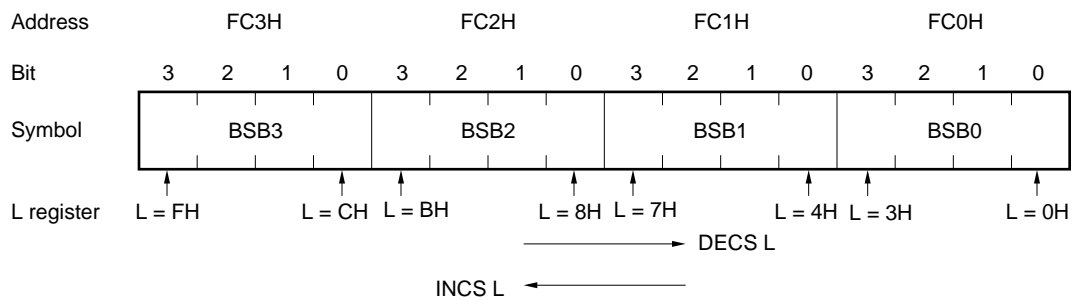

- Remarks 1. In the pmem.@L addressing, the specified bit moves corresponding to the L register.
- 2. In the pmem.@L addressing, the BSB can be manipulated regardless of MBE/MBS specification.

7. INTERRUPT FUNCTION AND TEST FUNCTION

μ PD753017 has eight types of interrupt sources and two types of test sources. Among the test sources, INT2 is provided with two testable inputs for edge detection.

μ PD753017 has the following functions in the interrupt controller.

(1) Interrupt function

- Vectored interrupt function for hardware control, enabling/disabling the interrupt acceptance by the interrupt enable flag (IEXXX) and interrupt master enable flag (IME).
- Can set any interrupt start address.
- Multiple interrupts wherein the order of priority can be specified by the interrupt priority select register (IPS).
- Test function of interrupt request flag (IRQXXX). An interrupt generated can be checked by software.
- Release the standby mode. A release interrupt can be selected by the interrupt enable flag.

(2) Test function

- Test request flag (IRQXXX) generation can be checked by software.
- Release the standby mode. The test source to be released can be selected by the test enable flag.

Figure 7-1. Interrupt Control Circuit Block Diagram

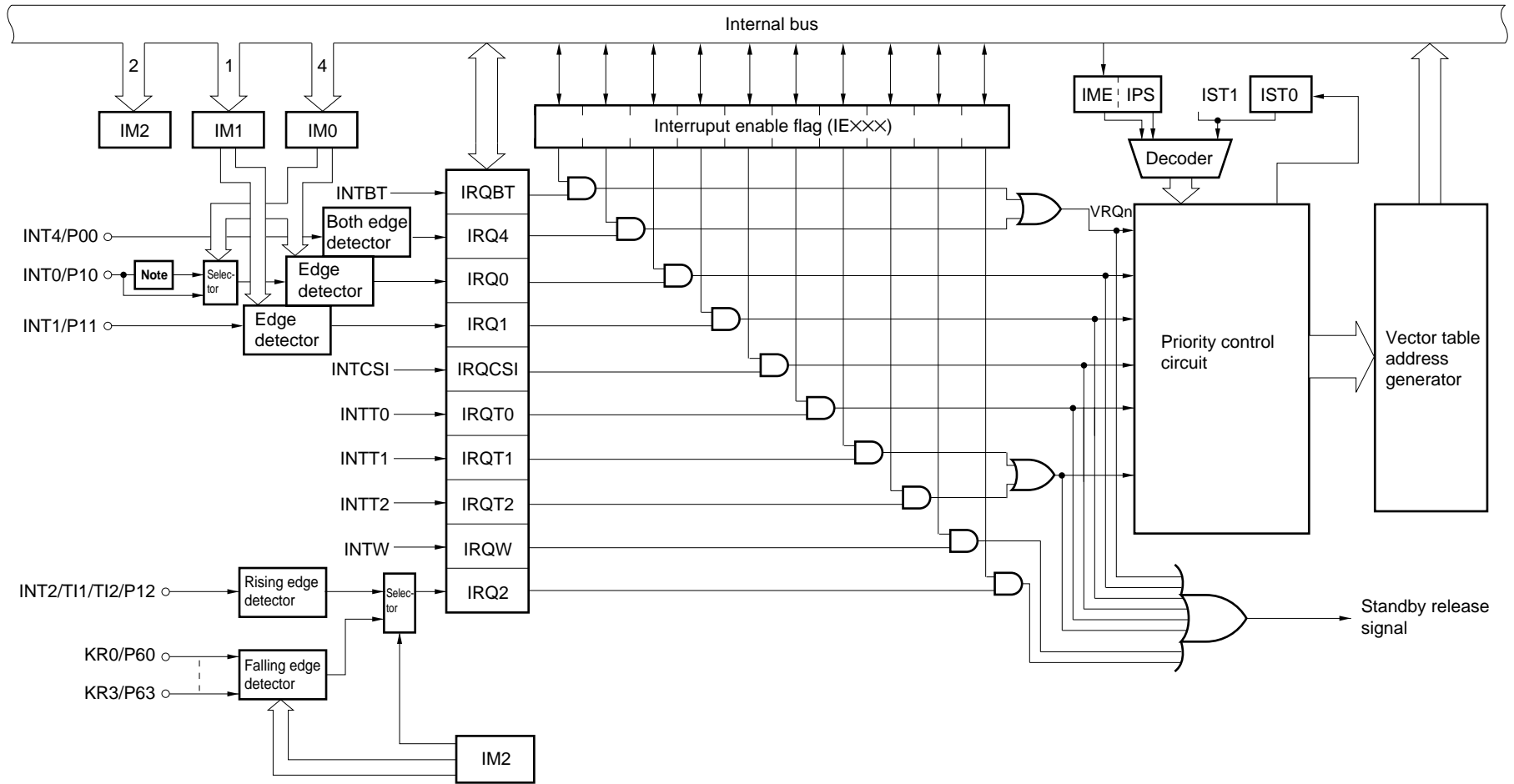

Note Noise eliminator (Standby release is disabled when noise eliminator is selected.)

8. STANDBY FUNCTION

In order to save power consumption while a program is in a standby mode, two types of standby modes (STOP mode and HALT mode) are provided for the μPD753017.

Table 8-1. Operation Status in Standby Mode

		STOP Mode	HALT Mode
Set instruction		STOP instruction	HALT instruction
System clock when set		Settable only when the main system clock is used.	Settable both by the main system clock and subsystem clock.
★ Operation status	Clock generator	Only the main system clock stops oscillation.	Only the CPU Φ halts (oscillation continues).
	Basic interval timer	Operation stops	Operation. ^{Note 1} (BT mode : Sets IRQBT at reference time intervals. WT mode: Generates reset signal when BT overflows.)
	Serial interface	Operable only when an external SCK input is selected as the serial clock.	Operable ^{Note 1}
	Timer/event counter	Operable only when a signal input to the T10-T12 pins is specified as the count clock.	Operable ^{Note 1}
	Watch timer	Operable when f _{XT} is selected as the count clock.	Operable
	LCD controller/driver	Operable only when f _{XT} is selected as the LCDCL.	Operable
	External interrupt	The INT1, 2, and 4 are operable. Only the INT0 is not operated. ^{Note 2}	
	CPU	The operation stops.	
Release signal		Interrupt request signal sent from the operable hardware enabled by the interrupt enable flag or RESET signal input.	

- Notes**
1. Cannot operate only when the main system clock stops.
 2. Can operate only when the noise eliminator is not used (IM02 = 1) by bit 2 of the edge detection mode register(IM0).

9. RESET FUNCTION

There are two reset inputs: external reset signal ($\overline{\text{RESET}}$) and reset signal sent from the basic interval timer/watchdog timer. When either one of the reset signals are input, an internal reset signal is generated. Figure 9-1 shows the circuit diagram of the above two inputs.

Figure 9-1. Configuration of Reset Function

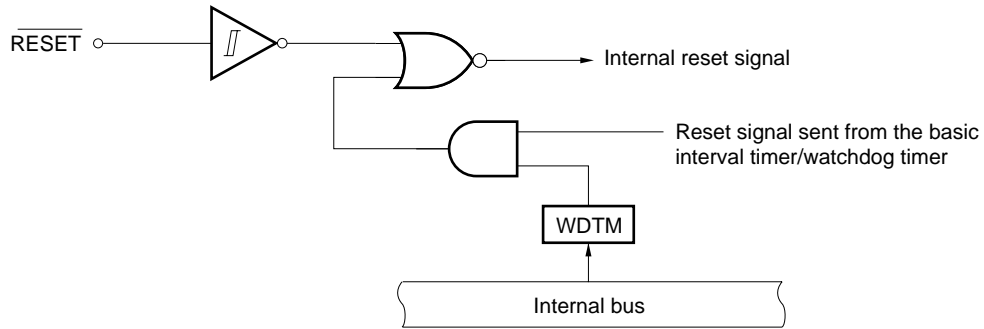

The μ PD753017 is set by the $\overline{\text{RESET}}$ signal generated and each device is initialized as listed in Table 9-1. Figure 9-2 shows the timing chart of the reset operation.

Figure 9-2. Reset Operation by $\overline{\text{RESET}}$ Signal Generation

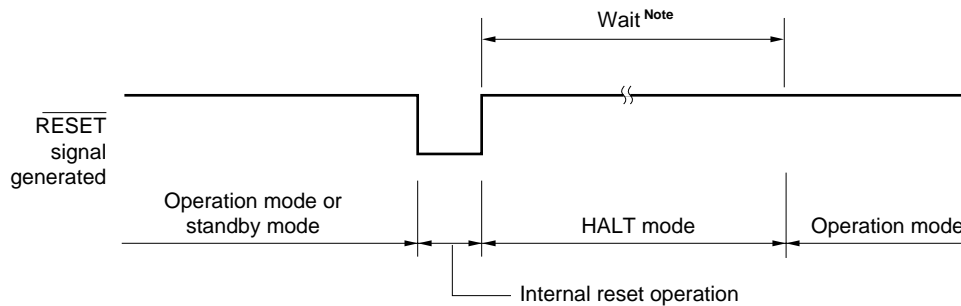

Note The following two times can be selected by the mask option.

$2^{17}/f_x$ (21.8 ms : at 6.00 MHz operation, 31.3 ms : at 4.19 MHz operation)

$2^{15}/f_x$ (5.46 ms : at 6.00 MHz operation, 7.81 ms : at 4.19 MHz operation)

Table 9-1. Status of Each Device After Reset (1/2)

Hardware		RESET Signal Generation in Standby Mode	RESET Signal Generation in Operation
Program counter (PC)	μPD753012, 753016	Sets the low-order 6 bits of program memory's address 0000H to the PC13-PC8 and the contents of address 0001H to the PC7-PC0.	Sets the low-order 6 bits of program memory's address 0000H to the PC13-PC8 and the contents of address 0001H to the PC7-PC0.
	μPD753017	Sets the low-order 7 bits of program memory's address 0000H to the PC14-PC8 and the contents of address 0001H to the PC7-PC0.	Sets the low-order 7 bits of program memory's address 0000H to the PC14-PC8 and the contents of address 0001H to the PC7-PC0.
PSW	Carry flag (CY)	Held	Undefined
	Skip flag (SK0-SK2)	0	0
	Interrupt status flag (IST0)	0	0
	Bank enable flag (MBE, RBE)	Sets the bit 6 of program memory's address 0000H to the RBE and bit 7 to the MBE.	Sets the bit 6 of program memory's address 0000H to the RBE and bit 7 to the MBE.
Stack pointer (SP)		Undefined	Undefined
Stack bank select register (SBS)		1000B	1000B
Data memory (RAM)		Held	Undefined
General-purpose register (X, A, H, L, D, E, B, C)		Held	Undefined
Bank select register (MBS, RBS)		0, 0	0, 0
Basic interval/ watchdog timer	Counter (BT)	Undefined	Undefined
	Mode register (BTM)	0	0
	Watchdog timer enable flag (WDTM)	0	0
Timer/event counter (T0)	Counter (T0)	0	0
	Modulo register (TMOD0)	FFH	FFH
	Mode register (TM0)	0	0
	TOE0, TOUT F/F	0, 0	0, 0
Timer/event counter (T1)	Counter (T1)	0	0
	Modulo register (TMOD1)	FFH	FFH
	Mode register (TM1)	0	0
	TOE1, TOUT F/F	0, 0	0, 0
Timer/event counter (T2)	Counter (T2)	0	0
	Modulo register (TMOD2)	FFH	FFH
	High level period setting modulo register (TMOD2H)	FFH	FFH
	Mode register (TM2)	0	0
	TOE2, TOUT F/F	0, 0	0, 0
	REMC, NRZ, NRZB	0, 0, 0	0, 0, 0
	TGCE	0	0
Watch timer	Mode register (WM)	0	0

Table 9-1. Status of Each Device After Reset (2/2)

Hardware		RESET Signal Generation in Standby Mode	RESET Signal Generation in Operation
Serial interface	Shift register (SIO)	Held	Undefined
	Operating mode register (CSIM)	0	0
	SBI control register (SBIC)	0	0
	Slave address register (SVA)	Held	Undefined
Clock generator, clock output circuit	Processor clock control register (PCC)	0	0
	System clock control register (SCC)	0	0
	Clock output mode register (CLOM)	0	0
Sub-oscillator control register (SOS)		0	0
LCD controller /driver	Display mode register (LCDM)	0	0
	Display control register (LCDC)	0	0
Interrupt function	Interrupt request flag (IRQXXX)	Reset (0)	Reset (0)
	Interrupt enable flag (IEXXX)	0	0
	Interrupt master enable flag (IME)	0	0
	INT0, 1, 2 mode registers (IM0, IM1, IM2)	0, 0, 0	0, 0, 0
	Priority selection register (IPS)	0	0
Digital port	Output buffer	Off	Off
	Output latch	Cleared (0)	Cleared (0)
	I/O mode registers (PMGA, PMGB)	0	0
	Pull-up resistor setting register (POGA)	0	0
Bit sequential buffer (BSB0-BSB3)		Held	Undefined

★ 10. MASK OPTION

The μ PD753017 has the following mask options.

- Mask option of P40 to P43 and P50 to P53
An on-chip pull-up resistor can be selected.
 - <1> Specifies an on-chip pull-up resistor in bit units.
 - <2> Does not specify an on-chip pull-up resistor.

- Mask option of V_{LC0} to V_{LC2} and BIAS pins
An on-chip split resistor for LDC driving can be selected.
 - <1> Does not specify an on-chip divider resistor
 - <2> Specifies four 10-k Ω (typ.) on-chip split resistors at the same time.
 - <3> Specifies four 100-k Ω (typ.) on-chip split resistors at the same time.

- Standby function mask option
Wait time can be selected by $\overline{\text{RESET}}$ signal input.
 - <1> $2^{17}/f_x$ (21.8 ms: at $f_x = 6.0$ MHz, 31.3 ms: at $f_x = 4.19$ MHz)
 - <2> $2^{15}/f_x$ (5.46 ms: at $f_x = 6.0$ MHz, 7.81 ms: at $f_x = 4.19$ MHz)

- Subsystem clock mask option
Selectable an on-chip feedback resistor can be used/cannot be used
 - <1> Make an on-chip feedback resistor usable
(Switch on-chip feedback resistor ON/OFF in software)
 - <2> Make an on-chip feedback resistor unusable
(Disconnects on-chip feedback resistor in hardware)

11. INSTRUCTION SETS AND THEIR OPERATIONS

(1) Operand identifiers and methods of use

Operands are written in the operand column of each instruction in accordance with the method of use for the operand identifier of the instruction. For details, refer to **RA75X Assembler Package User's Manual—Language (U12385E)**. If there are several elements, one of them is selected. Capital letters and the + and – symbols are key words and are written as they are.

For immediate data, appropriate numbers and labels are written.

Instead of the labels such as mem, fmem, pmem, and bit, the symbols of the registers can be written. However, there are restrictions in the labels that can be written for fmem and pmem. For details, refer to **User's Manual**.

Identifier	Format
reg	X, A, B, C, D, E, H, L
reg1	X, B, C, D, E, H, L
rp	XA, BC, DE, HL
rp1	BC, DE, HL
rp2	BC, DE
rp'	XA, BC, DE, HL, XA', BC', DE', HL'
rp'1	BC, DE, HL, XA', BC', DE', HL'
rpa	HL, HL+, HL–, DE, DL
rpa1	DE, DL
n4	4-bit immediate data or label
n8	8-bit immediate data or label
mem	8-bit immediate data or label ^{Note}
bit	2-bit immediate data or label
fmem	FB0H-FBFH, FF0H-FFFH immediate data or label
pmem	FC0H-FFFH immediate data or label
addr	0000H-2FFFH immediate data or label (μPD753012)
	0000H-3FFFH immediate data or label (μPD753016, 753017)
addr1	0000H-5FFFH immediate data or label
caddr	12-bit immediate data or label
faddr	11-bit immediate data or label
taddr	20H-7FH immediate data (where bit 0 = 0) or label
PORTn	PORT0-PORT7
IEXXX	IEBT, IET0-IET2, IE0-IE2, IE4, IECSI, IEW
RBn	RB0-RB3
MBn	MB0, MB1, MB2, MB3, MB15

Note mem can be only used even address in 8-bit data processing.

(2) Legend in explanation of operation

A	: A register, 4-bit accumulator
B	: B register
C	: C register
D	: D register
E	: E register
H	: H register
L	: L register
X	: X register
XA	: XA register pair; 8-bit accumulator
BC	: BC register pair
DE	: DE register pair
HL	: HL register pair
XA'	: XA' expanded register pair
BC'	: BC' expanded register pair
DE'	: DE' expanded register pair
HL'	: HL' expanded register pair
PC	: Program counter
SP	: Stack pointer
CY	: Carry flag, bit accumulator
PSW	: Program status word
MBE	: Memory bank enable flag
RBE	: Register bank enable flag
PORT _n	: Port n (n = 0-7)
IME	: Interrupt master enable flag
IPS	: Interrupt priority selection register
IEXXX	: Interrupt enable flag
RBS	: Register bank selection register
MBS	: Memory bank selection register
PCC	: Processor clock control register
.	: Separation between address and bit
(XX)	: The contents addressed by XX
XXH	: Hexadecimal data

(3) Explanation of symbols under addressing area column

*1	MB = MBE•MBS (MBS = 0-3, 15)		Data memory addressing
*2	MB = 0		
*3	MBE = 0 : MB = 0 (00H-7FH) MB = 15 (F80H-FFFH) MBE = 1 : MB = MBS (MBS = 0-3, 15)		
*4	MB = 15, fmem = FB0H-FBFH, FF0H-FFFH		
*5	MB = 15, pmem = FC0H-FFFH		
*6	μPD753012	addr = 0000H-2FFFH	Program memory addressing
	μPD753016 753017	addr = 0000H-3FFFH	
*7	μPD753012 753016 753017 (In Mk I mode)	addr = (Current PC) – 15 to (Current PC) – 1 (Current PC) + 2 to (Current PC) + 16	
	μPD753017 (In Mk II mode)	addr1 = (Current PC) – 15 to (Current PC) – 1 (Current PC) + 2 to (Current PC) + 16	
*8	μPD753012	caddr = 0000H-0FFFH(PC _{13, 12} = 00B) or 1000H-1FFFH(PC _{13, 12} = 01B) or 2000H-2FFFH(PC _{13, 12} = 10B)	
	μPD753016	caddr = 0000H-0FFFH(PC _{13, 12} = 00B) or 1000H-1FFFH(PC _{13, 12} = 01B) or 2000H-2FFFH(PC _{13, 12} = 10B) or 3000H-3FFFH(PC _{13, 12} = 11B)	
	μPD753017	caddr = 0000H-0FFFH(PC _{14, 13, 12} = 000B) or 1000H-1FFFH(PC _{14, 13, 12} = 001B) or 2000H-2FFFH(PC _{14, 13, 12} = 010B) or 3000H-3FFFH(PC _{14, 13, 12} = 011B) or 4000H-4FFFH(PC _{14, 13, 12} = 100B) or 5000H-5FFFH(PC _{14, 13, 12} = 101B)	
*9	faddr = 0000H-07FFH		
*10	taddr = 0020H-007FH		
*11	μPD753012	addr1 = 0000H-2FFFH	
	μPD753016	addr1 = 0000H-3FFFH	
	μPD753017	addr1 = 0000H-5FFFH	

- Remarks**
1. MB indicates memory bank that can be accessed.
 2. In *2, MB = 0 independently of how MBE and MBS are set.
 3. In *4 and *5, MB = 15 independently of how MBE and MBS are set.
 4. *6 to *11 indicate the areas that can be addressed.

(4) Explanation of number of machine cycles column

S denotes the number of machine cycles required by skip operation when a skip instruction is executed.

The value of S varies as follows.

- When no skip is made: $S = 0$
- When the skipped instruction is a 1- or 2-byte instruction: $S = 1$
- When the skipped instruction is a 3-byte instruction^{Note}: $S = 2$

Note 3-byte instruction: BR !addr, BRA !addr1, CALL !addr or CALLA !addr1 instruction

Caution The GETI instruction is skipped in one machine cycle.

One machine cycle is equal to one cycle of CPU clock Φ ($= t_{CY}$); time can be selected from among four types by setting PCC.

Instruction Group	Mnemonic	Operand	Number of Bytes	Number of Machine Cycles	Operation	Addressing Area	Skip Condition
Transfer instruction	MOV	A, #n4	1	1	A ← n4		String effect A
		reg1, #n4	2	2	reg1 ← n4		
		XA, #n8	2	2	XA ← n8		String effect A
		HL, #n8	2	2	HL ← n8		String effect B
		rp2, #n8	2	2	rp2 ← n8		
		A, @HL	1	1	A ← (HL)	*1	
		A, @HL+	1	2+S	A ← (HL), then L ← L+1	*1	L = 0
		A, @HL-	1	2+S	A ← (HL), then L ← L-1	*1	L = FH
		A, @rpa1	1	1	A ← (rpa1)	*2	
		XA, @HL	2	2	XA ← (HL)	*1	
		@HL, A	1	1	(HL) ← A	*1	
		@HL, XA	2	2	(HL) ← XA	*1	
		A, mem	2	2	A ← (mem)	*3	
		XA, mem	2	2	XA ← (mem)	*3	
		mem, A	2	2	(mem) ← A	*3	
		mem, XA	2	2	(mem) ← XA	*3	
		A, reg	2	2	A ← reg		
		XA, rp'	2	2	XA ← rp'		
	reg1, A	2	2	reg1 ← A			
	rp'1, XA	2	2	rp'1 ← XA			
	XCH	A, @HL	1	1	A ↔ (HL)	*1	
		A, @HL+	1	2+S	A ↔ (HL), then L ← L+1	*1	L = 0
		A, @HL-	1	2+S	A ↔ (HL), then L ← L-1	*1	L = FH
		A, @rpa1	1	1	A ↔ (rpa1)	*2	
		XA, @HL	2	2	XA ↔ (HL)	*1	
		A, mem	2	2	A ↔ (mem)	*3	
		XA, mem	2	2	XA ↔ (mem)	*3	
		A, reg1	1	1	A ↔ reg1		
XA, rp'		2	2	XA ↔ rp'			

Instruction Group	Mnemonic	Operand	Number of Bytes	Number of Machine Cycles	Operation	Addressing Area	Skip Condition
Table	MOVT ^{Note 1}	XA, @PCDE	1	3	XA ← (PC ₁₃₋₈ +DE) _{ROM} <div style="background-color: #e0e0e0; padding: 2px;">• μPD753017 XA ← (PC₁₄₋₈+DE)_{ROM}</div>		
		XA, @PCXA	1	3	XA ← (PC ₁₃₋₈ +XA) _{ROM} <div style="background-color: #e0e0e0; padding: 2px;">• μPD753017 XA ← (PC₁₄₋₈+XA)_{ROM}</div>		
		XA, @BCDE ^{Note 2}	1	3	XA ← (B _{1,0} +CDE) _{ROM} <div style="background-color: #e0e0e0; padding: 2px;">• μPD753017 XA ← (B₂₋₀+CDE)_{ROM}</div>	*6	
		XA, @BCXA ^{Note 2}	1	3	XA ← (B _{1,0} +CXA) _{ROM} <div style="background-color: #e0e0e0; padding: 2px;">• μPD753017 XA ← (B₂₋₀+CXA)_{ROM}</div>	*6	
Bit transfer	MOV1	CY, fmem.bit	2	2	CY ← (fmem.bit)	*4	
		CY, pmem.@L	2	2	CY ← (pmem ₇₋₂ +L ₃₋₂ .bit(L ₁₋₀))	*5	
		CY, @H+mem.bit	2	2	CY ← (H+mem ₃₋₀ .bit)	*1	
		fmem.bit, CY	2	2	(fmem.bit) ← CY	*4	
		pmem.@L, CY	2	2	(pmem ₇₋₂ +L ₃₋₂ .bit(L ₁₋₀)) ← CY	*5	
		@H+mem.bit, CY	2	2	(H+mem ₃₋₀ .bit) ← CY	*1	
Operation	ADDS	A, #n4	1	1+S	A ← A+n4		carry
		XA, #n8	2	2+S	XA ← XA+n8		carry
		A, @HL	1	1+S	A ← A+(HL)	*1	carry
		XA, rp'	2	2+S	XA ← XA+rp'		carry
		rp'1, XA	2	2+S	rp'1 ← rp'1+XA		carry
	ADDC	A, @HL	1	1	A, CY ← A+(HL)+CY	*1	
		XA, rp'	2	2	XA, CY ← XA+rp'+CY		
		rp'1, XA	2	2	rp'1, CY ← rp'1+XA+CY		
	SUBS	A, @HL	1	1+S	A ← A-(HL)	*1	borrow
		XA, rp'	2	2+S	XA ← XA-rp'		borrow
		rp'1, XA	2	2+S	rp'1 ← rp'1-XA		borrow
	SUBC	A, @HL	1	1	A, CY ← A-(HL)-CY	*1	
XA, rp'		2	2	XA, CY ← XA-rp'-CY			
rp'1, XA		2	2	rp'1, CY ← rp'1-XA-CY			

Notes 1. The above operations in the shaded boxes can be performed only in the Mk II mode. The other operations can be performed only in the Mk I mode.

2. Only the following bits are valid for the B register.

μPD753012, 753016 : low-order 2 bits

μPD753017 : low-order 3 bits

★ **Remark** PC₁₄ is fixed to 0 when the μPD753017 is set in the Mk I mode.

Instruction Group	Mnemonic	Operand	Number of Bytes	Number of Machine Cycles	Operation	Addressing Area	Skip Condition
Operating instructions	AND	A, #n4	2	2	$A \leftarrow A \wedge n4$		
		A, @HL	1	1	$A \leftarrow A \wedge (HL)$	*1	
		XA, rp'	2	2	$XA \leftarrow XA \wedge rp'$		
		rp'1, XA	2	2	$rp'1 \leftarrow rp'1 \wedge XA$		
	OR	A, #n4	2	2	$A \leftarrow A \vee n4$		
		A, @HL	1	1	$A \leftarrow A \vee (HL)$	*1	
		XA, rp'	2	2	$XA \leftarrow XA \vee rp'$		
		rp'1, XA	2	2	$rp'1 \leftarrow rp'1 \vee XA$		
	XOR	A, #n4	2	2	$A \leftarrow A \vee n4$		
		A, @HL	1	1	$A \leftarrow A \vee (HL)$	*1	
		XA, rp'	2	2	$XA \leftarrow XA \vee rp'$		
		rp'1, XA	2	2	$rp'1 \leftarrow rp'1 \vee XA$		
Accumulator manipulation instructions	RORC	A	1	1	$CY \leftarrow A_0, A_3 \leftarrow CY, A_{n-1} \leftarrow A_n$		
	NOT	A	2	2	$A \leftarrow \bar{A}$		
Increment and Decrement instructions	INCS	reg	1	1+S	$reg \leftarrow reg+1$		reg=0
		rp1	1	1+S	$rp1 \leftarrow rp1+1$		rp1=00H
		@HL	2	2+S	$(HL) \leftarrow (HL)+1$	*1	(HL)=0
		mem	2	2+S	$(mem) \leftarrow (mem)+1$	*3	(mem)=0
	DECS	reg	1	1+S	$reg \leftarrow reg-1$		reg=FFH
		rp'	2	2+S	$rp' \leftarrow rp'-1$		rp'=FFH
Comparison instruction	SKE	reg, #n4	2	2+S	Skip if reg = n4		reg=n4
		@HL, #n4	2	2+S	Skip if (HL) = n4	*1	(HL) = n4
		A, @HL	1	1+S	Skip if A = (HL)	*1	A = (HL)
		XA, @HL	2	2+S	Skip if XA = (HL)	*1	XA = (HL)
		A, reg	2	2+S	Skip if A = reg		A=reg
		XA, rp'	2	2+S	Skip if XA = rp'		XA=rp'
Carry flag manipulation instruction	SET1	CY	1	1	$CY \leftarrow 1$		
	CLR1	CY	1	1	$CY \leftarrow 0$		
	SKT	CY	1	1+S	Skip if CY = 1		CY=1
	NOT1	CY	1	1	$CY \leftarrow \bar{CY}$		

Instruction Group	Mnemonic	Operand	Number of Bytes	Number of Machine Cycles	Operation	Addressing Area	Skip Condition
Memory bit manipulation instructions	SET1	mem.bit	2	2	(mem.bit) ← 1	*3	
		fmem.bit	2	2	(fmem.bit) ← 1	*4	
		pmem.@L	2	2	(pmem ₇₋₂ +L ₃₋₂ .bit(L ₁₋₀)) ← 1	*5	
		@H+mem.bit	2	2	(H+mem ₃₋₀ .bit) ← 1	*1	
	CLR1	mem.bit	2	2	(mem.bit) ← 0	*3	
		fmem.bit	2	2	(fmem.bit) ← 0	*4	
		pmem.@L	2	2	(pmem ₇₋₂ +L ₃₋₂ .bit(L ₁₋₀)) ← 0	*5	
		@H+mem.bit	2	2	(H+mem ₃₋₀ .bit) ← 0	*1	
	SKT	mem.bit	2	2+S	Skip if (mem.bit)=1	*3	(mem.bit)=1
		fmem.bit	2	2+S	Skip if (fmem.bit)=1	*4	(fmem.bit)=1
		pmem.@L	2	2+S	Skip if (pmem ₇₋₂ +L ₃₋₂ .bit(L ₁₋₀))=1	*5	(pmem.@L)=1
		@H+mem.bit	2	2+S	Skip if (H+mem ₃₋₀ .bit)=1	*1	(@H+mem.bit)=1
	SKF	mem.bit	2	2+S	Skip if (mem.bit)=0	*3	(mem.bit)=0
		fmem.bit	2	2+S	Skip if (fmem.bit)=0	*4	(fmem.bit)=0
		pmem.@L	2	2+S	Skip if (pmem ₇₋₂ +L ₃₋₂ .bit(L ₁₋₀))=0	*5	(pmem.@L)=0
		@H+mem.bit	2	2+S	Skip if (H+mem ₃₋₀ .bit)=0	*1	(@H+mem.bit)=0
	SKTCLR	fmem.bit	2	2+S	Skip if (fmem.bit)=1 and clear	*4	(fmem.bit)=1
		pmem.@L	2	2+S	Skip if (pmem ₇₋₂ +L ₃₋₂ .bit(L ₁₋₀))=1 and clear	*5	(pmem.@L)=1
		@H+mem.bit	2	2+S	Skip if (H+mem ₃₋₀ .bit)=1 and clear	*1	(@H+mem.bit)=1
	AND1	CY, fmem.bit	2	2	CY ← CY ∧ (fmem.bit)	*4	
		CY, pmem.@L	2	2	CY ← CY ∧ (pmem ₇₋₂ +L ₃₋₂ .bit(L ₁₋₀))	*5	
		CY, @H+mem.bit	2	2	CY ← CY ∧ (H+mem ₃₋₀ .bit)	*1	
	OR1	CY, fmem.bit	2	2	CY ← CY ∨ (fmem.bit)	*4	
		CY, pmem.@L	2	2	CY ← CY ∨ (pmem ₇₋₂ +L ₃₋₂ .bit(L ₁₋₀))	*5	
CY, @H+mem.bit		2	2	CY ← CY ∨ (H+mem ₃₋₀ .bit)	*1		
XOR1	CY, fmem.bit	2	2	CY ← CY ⊕ (fmem.bit)	*4		
	CY, pmem.@L	2	2	CY ← CY ⊕ (pmem ₇₋₂ +L ₃₋₂ .bit(L ₁₋₀))	*5		
	CY, @H+mem.bit	2	2	CY ← CY ⊕ (H+mem ₃₋₀ .bit)	*1		

Instruction Group	Mnemonic	Operand	Number of Bytes	Number of Machine Cycles	Operation	Addressing Area	Skip Condition	
Branch instructions	BR ^{Note 1}	addr	–	–	PC ₁₃₋₀ ← addr (Select appropriate instruction from among BR !addr, BRCB !caddr, and BR \$addr according to the assembler being used. BR !addr BRCB !caddr BR \$addr)	*6		
		addr1	–	–	• μPD753017 PC ₁₄₋₀ ← addr1 (Select appropriate instruction from among BR !addr, BRA !caddr1 BRCB !caddr, and BR \$addr according to the assembler being used. BR !addr BRA !caddr1 BRCB !caddr BR \$addr)	*11		
		!addr	3	3	PC ₁₃₋₀ ← addr • μPD753017 PC ₁₄ ← 0, PC ₁₃₋₀ ← addr	*6		
		\$addr	1	2	PC ₁₃₋₀ ← addr	*7		
		\$addr1	1	2	• μPD753017 PC ₁₄₋₀ ← addr1			
		PCDE	2	3	PC ₁₃₋₀ ← PC ₁₃₋₈ +DE • μPD753017 PC ₁₄₋₀ ← PC ₁₄₋₈ +DE			
		PCXA	2	3	PC ₁₃₋₀ ← PC ₁₃₋₈ +XA • μPD753017 PC ₁₄₋₀ ← PC ₁₄₋₈ +XA			
		BCDE ^{Note 2}	2	3	PC ₁₃₋₀ ← B _{1,0} +CDE • μPD753017 PC ₁₄₋₀ ← B ₂₋₀ +CDE	*6		
						*11		
		BCXA ^{Note 2}	2	3	PC ₁₃₋₀ ← B _{1,0} +CXA • μPD753017 PC ₁₄₋₀ ← B ₂₋₀ +CXA	*6		
						*11		
		BRA ^{Note 1}	!addr	3	3	• μPD753012, 753016 PC ₁₃₋₀ ← addr	*6	
			!addr1	3	3	• μPD753017 PC ₁₄₋₀ ← addr1	*11	

Notes 1. The above operations in the shaded boxes can be performed only in the Mk II mode. The other operations can be performed only in the Mk I mode.

2. Only the following bits are valid for the B register.

μPD753012, 753016 : low-order 2 bits

μPD753017 : low-order 3 bits

★ **Remark** PC₁₄ is fixed to 0 when the μPD753017 is set in the Mk I mode.

Instruction Group	Mnemonic	Operand	Number of Bytes	Number of Machine Cycles	Operation	Addressing Area	Skip Condition
Branch instructions	BRCB ^{Note}	!caddr	2	2	PC ₁₃₋₀ ← PC _{13,12} +caddr ₁₁₋₀	*8	
					• μPD753017 PC ₁₄₋₀ ← PC _{14,13,12} +caddr ₁₁₋₀		
Subroutine stack control instructions	CALLA ^{Note}	!addr	3	3	• μPD753012, 753016 (SP-5)(SP-6)(SP-3)(SP-4) ← 0, 0, PC ₁₃₋₀ (SP-2) ← x, x, MBE, RBE PC ₁₃₋₀ ← addr, SP ← SP-6	*6	
		!addr1	3	3	• μPD753017 (SP-5)(SP-6)(SP-3)(SP-4) ← 0, PC ₁₄₋₀ (SP-2) ← x, x, MBE, RBE PC ₁₄₋₀ ← addr1, SP ← SP-6	*11	
	CALL ^{Note}	!addr	3	3	(SP-4)(SP-1)(SP-2) ← PC ₁₁₋₀ (SP-3) ← MBE, RBE, PC ₁₃ , PC ₁₂ PC ₁₃₋₀ ← addr, SP ← SP-4	*6	
				4	• μPD753012, 753016 (SP-5)(SP-6)(SP-3)(SP-4) ← 0, 0, PC ₁₃₋₀ (SP-2) ← x, x, MBE, RBE PC ₁₃₋₀ ← addr, SP ← SP-6		
4				• μPD753017 (SP-5)(SP-6)(SP-3)(SP-4) ← 0, PC ₁₄₋₀ (SP-2) ← x, x, MBE, RBE PC ₁₄ ← 0, PC ₁₃₋₀ ← addr, SP ← SP-6			
CALLF ^{Note}	!faddr	2	2	(SP-4)(SP-1)(SP-2) ← PC ₁₁₋₀ (SP-3) ← MBE, RBE, PC ₁₃ , PC ₁₂ PC ₁₃₋₀ ← 000+faddr, SP ← SP-4	*9		
			3	• μPD753012, 753016 (SP-5)(SP-6)(SP-3)(SP-4) ← 0, 0, PC ₁₃₋₀ (SP-2) ← x, x, MBE, RBE PC ₁₃₋₀ ← 000+faddr, SP ← SP-6			
			3	• μPD753017 (SP-5)(SP-6)(SP-3)(SP-4) ← 0, PC ₁₄₋₀ (SP-2) ← x, x, MBE, RBE PC ₁₄₋₀ ← 0000+faddr, SP ← SP-6			

Note The above operations in the shaded boxes can be performed only in the Mk II mode. The other operations can be performed only in the Mk I mode.

★ **Remark** PC₁₄ is fixed to 0 when the μPD753017 is set in the Mk I mode.

Instruction Group	Mnemonic	Operand	Number of Bytes	Number of Machine Cycles	Operation	Addressing Area	Skip Condition
Subroutine stack control instructions	RET ^{Note}		1	3	MBE, RBE, PC ₁₃ , PC ₁₂ ← (SP+1) PC ₁₁₋₀ ← (SP)(SP+3)(SP+2), SP ← SP+4 • μPD753012, 753016 X, X, MBE, RBE ← (SP+4) 0, 0, PC ₁₃ , PC ₁₂ ← (SP+1) PC ₁₁₋₀ ← (SP)(SP+3)(SP+2), SP ← SP+6 • μPD753017 X, X, MBE, RBE ← (SP+4) 0, PC ₁₄ , PC ₁₃ , PC ₁₂ ← (SP+1) PC ₁₁₋₀ ← (SP)(SP+3)(SP+2), SP ← SP+6		
	RETS ^{Note}		1	3+S	MBE, RBE, PC ₁₃ , PC ₁₂ ← (SP+1) PC ₁₁₋₀ ← (SP)(SP+3)(SP+2), SP ← SP+4 then skip unconditionally • μPD753012, 753016 X, X, MBE, RBE ← (SP+4) 0, 0, PC ₁₃ , PC ₁₂ ← (SP+1) PC ₁₁₋₀ ← (SP)(SP+3)(SP+2), SP ← SP+6 then skip unconditionally • μPD753017 X, X, MBE, RBE ← (SP+4) 0, PC ₁₄ , PC ₁₃ , PC ₁₂ ← (SP+1) PC ₁₁₋₀ ← (SP)(SP+3)(SP+2), SP ← SP+6 then skip unconditionally		Unconditional
	RETJ ^{Note}		1	3	MBE, RBE, PC ₁₃ , PC ₁₂ ← (SP+1) PC ₁₁₋₀ ← (SP)(SP+3)(SP+2) PSW ← (SP+4)(SP+5), SP ← SP+6 • μPD753012, 753016 0, 0, PC ₁₃ , PC ₁₂ ← (SP+1) PC ₁₁₋₀ ← (SP)(SP+3)(SP+2) PSW ← (SP+4)(SP+5), SP ← SP+6 • μPD753017 0, PC ₁₄ , PC ₁₃ , PC ₁₂ ← (SP+1) PC ₁₁₋₀ ← (SP)(SP+3)(SP+2) PSW ← (SP+4)(SP+5), SP ← SP+6		

Note The above operations in the shaded boxes can be performed only in the Mk II mode. The other operations can be performed only in the Mk I mode.

★ **Remark** PC₁₄ is fixed to 0 when the μPD753017 is set in the Mk I mode.

Instruction Group	Mnemonic	Operand	Number of Bytes	Number of Machine Cycles	Operation	Addressing Area	Skip Condition
Subroutine stack control instructions	PUSH	rp	1	1	$(SP-1)(SP-2) \leftarrow rp, SP \leftarrow SP-2$		
		BS	2	2	$(SP-1) \leftarrow MBS, (SP-2) \leftarrow RBS, SP \leftarrow SP-2$		
	POP	rp	1	1	$rp \leftarrow (SP+1)(SP), SP \leftarrow SP+2$		
		BS	2	2	$MBS \leftarrow (SP+1), RBS \leftarrow (SP), SP \leftarrow SP+2$		
Interrupt control instructions	EI		2	2	$IME(IPS.3) \leftarrow 1$		
		IEXXX	2	2	$IEXXX \leftarrow 1$		
	DI		2	2	$IME(IPS.3) \leftarrow 0$		
		IEXXX	2	2	$IEXXX \leftarrow 0$		
Input/output instructions	IN ^{Note 1}	A, PORTn	2	2	$A \leftarrow PORTn \quad (n = 0-7)$		
		XA, PORTn	2	2	$XA \leftarrow PORTn+1, PORTn \quad (n = 4, 6)$		
	OUT ^{Note 1}	PORTn, A	2	2	$PORTn \leftarrow A \quad (n = 2-7)$		
		PORTn, XA	2	2	$PORTn+1, PORTn \leftarrow XA \quad (n = 4, 6)$		
CPU control instruction	HALT		2	2	Set HALT mode (PCC.2 $\leftarrow 1$)		
	STOP		2	2	Set STOP mode (PCC.3 $\leftarrow 1$)		
	NOP		1	1	No operation		
Special instruction	SEL	RBn	2	2	$RBS \leftarrow n \quad (n = 0-3)$		
		MBn	2	2	$MBS \leftarrow n \quad (n = 0-3, 15)$		
	GETI ^{Notes 2, 3}	taddr	1	3	<ul style="list-style-type: none"> When TBR instruction $PC_{13-0} \leftarrow (taddr)_{5-0} + (taddr+1)$ 	*10	Depending on the reference instruction
					<ul style="list-style-type: none"> When TCALL instruction $(SP-4)(SP-1)(SP-2) \leftarrow PC_{11-0}$ $(SP-3) \leftarrow MBE, RBE, PC_{13}, PC_{12}$ $PC_{13-0} \leftarrow (taddr)_{5-0} + (taddr+1)$ $SP \leftarrow SP-4$ 		
					<ul style="list-style-type: none"> When instruction other than TBR and TCALL instructions (taddr) (taddr+1) instruction is executed 		
					<ul style="list-style-type: none"> μPD753017 When TBR instruction $PC_{13-0} \leftarrow (taddr)_{5-0} + (taddr+1)$ $PC_{14} \leftarrow 0$ 		
1	3	<ul style="list-style-type: none"> When TCALL instruction $(SP-5)(SP-6)(SP-3)(SP-4) \leftarrow 0, PC_{14-0}$ $(SP-2) \leftarrow X, X, MBE, RBE$ $PC_{13-0} \leftarrow (taddr)_{5-0} + (taddr+1)$ $SP \leftarrow SP-6, PC_{14} \leftarrow 0$ 	Depending on the reference instruction				
		<ul style="list-style-type: none"> When instruction other than TBR and TCALL instructions (taddr) (taddr+1) instruction is executed 					

- Notes 1.** While the IN instruction and OUT instruction are being executed, the MBE must be set to 0 or 1 and MBS must be set to 15.
- 2.** The shaded area is applicable only to the Mk II mode. The other area is applicable only to Mk I mode.
- 3.** The TBR and TCALL instructions are the table definition assembler pseudo instructions of the GETI instruction.

★ **Remark** PC₁₄ is fixed to 0 when the μPD753017 is set in the Mk I mode.

12. ELECTRICAL SPECIFICATIONS

Absolute Maximum Ratings (T_A = 25 °C)

Parameter	Symbol	Conditions	Ratings	Unit	
Supply voltage	V _{DD}		-0.3 to +7.0	V	
Input voltage	V _{I1}	Other than ports 4 and 5	-0.3 to V _{DD} +0.3	V	
	V _{I2}	Ports 4 and 5	Pull-up resistor provided	-0.3 to V _{DD} +0.3	V
			N-ch open drain	-0.3 to +14	V
Output voltage	V _O		-0.3 to V _{DD} +0.3	V	
High-level output current	I _{OH}	Per pin	-10	mA	
		Total of all pins	-30	mA	
Low-level output current	I _{OL}	Per pin	30	mA	
		Total of all pins	200	mA	
Operating ambient temperature	T _A		-40 to +85	°C	
Storage temperature	T _{stg}		-65 to +150	°C	

Caution If any of the parameters exceeds the absolute maximum ratings, even momentarily, the quality of the product may be impaired. The absolute maximum ratings are values that may physically damage the product(s). Be sure to use the product(s) within the ratings.

Capacitance (T_A = 25 °C, V_{DD} = 0 V)

Parameter	Symbol	Conditions	MIN.	TYP.	MAX.	Unit
Input capacitance	C _{IN}	f = 1 MHz			15	pF
Output capacitance	C _{OUT}	Pins other than tested pins: 0 V			15	pF
I/O capacitance	C _{IO}				15	pF

Main System Clock Oscillator Characteristics (T_A = -40 to +85 °C)

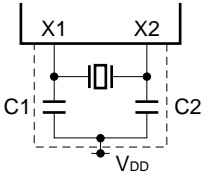
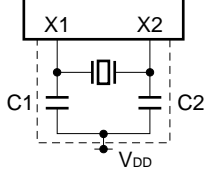
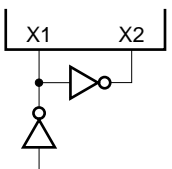
Oscillator	Recommended Constants	Parameter	Conditions	MIN.	TYP.	MAX.	Unit
Ceramic oscillator		Oscillation frequency (f _x) ^{Note 1}	V _{DD} = 2.2 to 5.5 V	1.0		6.0 ^{Note 2}	MHz
		Oscillation stabilization time ^{Note 3}	After V _{DD} has reached MIN. value of oscillation voltage range			4	ms
Crystal oscillator		Oscillation frequency (f _x) ^{Note 1}	V _{DD} = 2.2 to 5.5 V	1.0		6.0 ^{Note 2}	MHz
		Oscillation stabilization time ^{Note 3}	V _{DD} = 4.5 to 5.5 V			10	ms
			V _{DD} = 2.2 to 5.5 V			30	
External clock		X1 input frequency (f _x) ^{Note 1}	V _{DD} = 1.8 to 5.5 V	1.0		6.0 ^{Note 4}	MHz
		X1 input high-, low-level widths (t _{xH} , t _{xL})	V _{DD} = 1.8 to 5.5 V	83.3		500	ns

Notes 1. The oscillation frequency and X1 input frequency shown above indicate characteristics of the oscillator only. For the instruction execution time, refer to **AC Characteristics**.

- ★ **2.** When the oscillation frequency is 4.7 MHz < f_x ≤ 6.0 MHz at 2.2 V ≤ V_{DD} < 2.7 V, assign a value other than 0011 to the processor clock control register (PCC). If 0011 is assigned to PCC, one machine cycle falls short of the rated value of 0.85 μs.
- 3.** The oscillation stabilization time is the time required for oscillation to stabilize after V_{DD} has been applied or STOP mode has been released.
- ★ **4.** When the X1 input frequency is 4.19 MHz < f_x ≤ 6.0 MHz at 1.8 V ≤ V_{DD} < 2.7 V, assign a value other than 0011 to the processor clock control register (PCC). If 0011 is assigned to PCC, one machine cycle falls short of the rated value of 0.95 μs.

Caution When using the main system clock oscillator, wire the portion enclosed by the dotted line in the above figure as follows to prevent adverse influence from wiring capacitance:

- Keep the wiring length as short as possible.
- Do not cross the wiring with any other signal lines.
- Do not route the wiring in the vicinity of a line through which a high alternating current flows.
- Always keep the ground point of the capacitor of the oscillator at the same potential as V_{DD}.
- Do not ground to a power supply pattern through which a high current flows.
- Do not extract any signal from the oscillator.

Subsystem Clock Oscillator Characteristics (T_A = -40 to +85 °C)

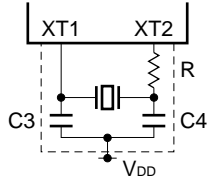
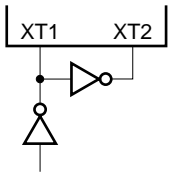
Oscillator	Recommended Constants	Parameter	Conditions	MIN.	TYP.	MAX.	Unit
Crystal oscillator		Oscillation frequency (f _{XT}) ^{Note 1}	V _{DD} = 2.2 to 5.5 V	32	32.768	35	kHz
		Oscillation stabilization time ^{Note 2}	V _{DD} = 4.5 to 5.5 V		1.0	2	s
			V _{DD} = 2.2 to 5.5 V			10	
External clock		XT1 input frequency (f _{XT}) ^{Note 1}	V _{DD} = 1.8 to 5.5 V	32		100	kHz
		XT1 input high-, low-level widths (t _{XTH} , t _{XTL})	V _{DD} = 1.8 to 5.5 V		5		15

- Notes**
- The oscillation frequency shown above indicate characteristics of the oscillator only. For the instruction execution time, refer to **AC Characteristics**.
 - The oscillation stabilization time is the time required for oscillation to be stabilized after V_{DD} has been applied.

Caution When using the subsystem clock oscillator, wire the portion enclosed by the dotted line in the above figure as follows to prevent adverse influence from to wiring capacitance:

- Keep the wiring length as short as possible.
- Do not cross the wiring with any other signal lines.
- Do not route the wiring in the vicinity of a line through which a high alternating current flows.
- Always keep the ground point of the capacitor of the oscillator at the same potential as V_{DD}.
- Do not ground to a power supply pattern through which a high current flows.
- Do not extract any signal from the oscillator.

The subsystem clock oscillator has a low amplification factor to reduce current dissipation and is more susceptible to noise than the main system clock oscillator. Therefore, exercise utmost care in wiring the subsystem clock oscillator.

Recommended Oscillator Constants

Ceramic oscillator (T_A = -40 to +85 °C)

Manufacturer	Part Number	Frequency (MHz)	Recommended Circuit Constant (pF)		Oscillation Voltage Range (V _{DD})		Remark
			C1	C2	MIN.	MAX.	
Murata Mfg. Co., Ltd.	CSB1000J ^{Note}	1.0	100	100	2.7	5.5	Rd = 5.6 kΩ
	CSA2.00MG040	2.0	100	100			
	CST2.00MG040		-	-			Capacitor-contained model
	CSA4.19MG	4.19	30	30	2.5	5.5	
	CST4.19MGW		-	-			
	CSA4.19MGU		30	30	2.2	5.5	
	CST4.19MGWU	-	-				Capacitor-contained model
	CSA6.00MG	6.0	30	30	2.7	5.5	
	CST6.00MGW		-	-			
	CSA6.00MGU		30	30	2.5	5.5	
CST6.00MGWU	-		-				Capacitor-contained model
Kyocera Corp.	KBR-1000F/Y	1.0	220	220	2.9	5.5	-20 to +85 °C
	KBR-2.0MS	2.0	82	82	3.1	5.5	
	KBR-4.19MSA	4.19	33	33	2.7	5.5	
	KBR-4.19MKS		-	-			
	PBRC 4.19A		-	-		-20 to +85 °C	
	PBRC 4.19B						
	KBR-6.0MSA	6.0	33	33	2.8	5.5	-20 to +85 °C
	KBR-6.0MKS		-	-			
	PBRC 6.00A		-	-		-20 to +85 °C	
	PBRC 6.00B		-	-			
TDK Corp.	FCR2.0MC3	2.0	30	30	2.0	5.5	
	FCR4.19MC5	4.19			2.5	5.5	
	FCR6.0MC5	6.0			2.7	5.5	

Note When using the CSB1000J (1.00 MHz) by Murata Mfg. Co., Ltd. as a ceramic oscillator, a limiting resistor (R_d = 5.6 kΩ) is necessary (refer to the figure below). The resistor is not necessary when using the other recommended oscillators.

Example of recommended main system clock oscillator (when using CSB1000J by Murata Mfg. Co., Ltd.)

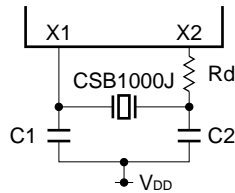

DC Characteristics (T_A = -40 to +85 °C, V_{DD} = 2.2 to 5.5 V)

Parameter	Symbol	Conditions		MIN.	TYP.	MAX.	Unit	
★ Low-level output current	I _{OL}	Per pin				15	mA	
		Total of all pins				120	mA	
High-level input voltage	V _{IH1}	Ports 2, 3		2.7 V ≤ V _{DD} ≤ 5.5 V	0.7 V _{DD}	V _{DD}	V	
				2.2 V ≤ V _{DD} < 2.7 V	0.9 V _{DD}	V _{DD}	V	
	V _{IH2}	Ports 0, 1, 6, 7, $\overline{\text{RESET}}$		2.7 V ≤ V _{DD} ≤ 5.5 V	0.8 V _{DD}	V _{DD}	V	
				2.2 V ≤ V _{DD} < 2.7 V	0.9 V _{DD}	V _{DD}	V	
	V _{IH3}	Ports 4, 5	Pull-up resistor provided	2.7 V ≤ V _{DD} ≤ 5.5 V	0.7 V _{DD}	V _{DD}	V	
				2.2 V ≤ V _{DD} < 2.7 V	0.9 V _{DD}	V _{DD}	V	
			N-ch open drain	2.7 V ≤ V _{DD} ≤ 5.5 V	0.7 V _{DD}	13	V	
				2.2 V ≤ V _{DD} < 2.7 V	0.9 V _{DD}	13	V	
V _{IH4}	X1, XT1		V _{DD} - 0.1		V _{DD}	V		
Low-level input voltage	V _{IL1}	Ports 2, 3, 4, 5		2.7 V ≤ V _{DD} ≤ 5.5 V	0	0.3 V _{DD}	V	
				2.2 V ≤ V _{DD} < 2.7 V	0	0.1 V _{DD}	V	
	V _{IL2}	Ports 0, 1, 6, 7, $\overline{\text{RESET}}$		2.7 V ≤ V _{DD} ≤ 5.5 V	0	0.2 V _{DD}	V	
				2.2 V ≤ V _{DD} < 2.7 V	0	0.1 V _{DD}	V	
	V _{IL3}	X1, XT1		0		0.1	V	
High-level output voltage	V _{OH}	$\overline{\text{SCK}}$, SO, ports 0, 2, 3, 6, 7, BP0 to 7 I _{OH} = -1 mA		V _{DD} - 0.5			V	
Low-level output voltage	V _{OL1}	$\overline{\text{SCK}}$, SO, ports 0, 2, 3, 4, 5, 6, 7, BP0 to 7		I _{OL} = 15 mA V _{DD} = 4.5 to 5.5 V	0.2	2.0	V	
				I _{OL} = 1.6 mA		0.4	V	
	V _{OL2}	SB0, 1	N-ch open drain Pull-up resistor ≥ 1 kΩ			0.2 V _{DD}	V	
High-level input leakage current	I _{LIH1}	V _{IN} = V _{DD}	Pins other than X1, XT1			3	μA	
	I _{LIH2}		X1, XT1			20	μA	
	I _{LIH3}	V _{IN} = 13 V	Ports 4, 5 (N-ch open drain)			20	μA	
Low-level input leakage current	I _{LIL1}	V _{IN} = 0 V	Pins other than X1, XT1, ports 4 and 5			-3	μA	
			X1, XT1			-20	μA	
	Ports 4, 5 (N-ch open drain) When input instruction is not executed			-3	μA			
	Ports 4, 5 (N-ch open drain) When input instruction is executed		V _{DD} = 5 V	-10	-27	μA		
			V _{DD} = 3 V	-3	-8	μA		
High-level output leakage current	I _{LOH1}	V _{OUT} = V _{DD}	SCK, SO/SB0, SB1, ports 2, 3, 6, 7, ports 4, 5 (with on-chip pull-up resistor), BP0 to 7			3	μA	
	I _{LOH2}	V _{OUT} = 13 V	Ports 4, 5 (N-ch open drain)			20	μA	
Low-level output leakage current	I _{LOL}	V _{OUT} = 0 V				-3	μA	
Internal pull-up resistor	R _{L1}	V _{IN} = 0 V	Ports 0, 1, 2, 3, 6, 7 (except P00 pin)		50	100	200	kΩ
	R _{L2}		Ports 4, 5 (mask option)		15	30	60	kΩ

DC Characteristics (T_A = -40 to +85 °C, V_{DD} = 2.2 to 5.5 V)

Parameter	Symbol	Conditions		MIN.	TYP.	MAX.	Unit
LCD drive voltage	V _{LCD}			2.2		V _{DD}	V
LCD divider resistor ^{Note 1}	R _{LCD1}			50	100	200	kΩ
	R _{LCD2}			5	10	20	kΩ
LCD output voltage deviation ^{Note 2} (common)	V _{ODC}	I _O = ±5μA	V _{LCD0} = V _{LCD} V _{LCD1} = V _{LCD} × 2/3 V _{LCD2} = V _{LCD} × 1/3	0		±0.2	V
LCD output voltage deviation ^{Note 2} (segment)	V _{ODS}	I _O = ±1μA	2.2 V ≤ V _{LCD} ≤ V _{DD}	0		±0.2	V
Supply current ^{Note 3}	I _{DD1}	6.00 MHz ^{Note 4} crystal oscillation C1 = C2 = 22 pF	V _{DD} = 5.0 V ± 10 % ^{Note 5}		1.9	6.0	mA
			V _{DD} = 3.0 V ± 10 % ^{Note 6}		0.4	1.3	mA
	I _{DD2}	C1 = C2 = 22 pF	HALT mode	V _{DD} = 5.0 V ± 10 %	0.72	2.1	mA
				V _{DD} = 3.0 V ± 10 %	0.27	0.8	mA
	I _{DD1}	4.19 MHz ^{Note 4} crystal oscillation C1 = C2 = 22 pF	V _{DD} = 5.0 V ± 10 % ^{Note 5}		1.5	4.0	mA
			V _{DD} = 3.0 V ± 10 % ^{Note 6}		0.25	0.75	mA
	I _{DD2}	C1 = C2 = 22 pF	HALT mode	V _{DD} = 5.0 V ± 10 %	0.7	2.0	mA
				V _{DD} = 3.0 V ± 10 %	0.23	0.7	mA
	I _{DD3}	32.768 kHz ^{Note 7} crystal oscillation	Low-voltage mode ^{Note 8}	V _{DD} = 3.0 V ± 10 %	12	35	μA
				V _{DD} = 2.5 V ± 10 %	4.5	12	μA
				V _{DD} = 3.0 V, T _A = 25 °C	12	24	μA
			Low current dissipation mode ^{Note 9}	V _{DD} = 3.0 V ± 10 %	6	18	μA
				V _{DD} = 3.0 V, T _A = 25 °C	6	12	μA
	I _{DD4}	HALT mode	Low-voltage mode ^{Note 8}	V _{DD} = 3.0 V ± 10 %	8.5	25	μA
				V _{DD} = 2.5 V ± 10 %	3	9	μA
V _{DD} = 3.0 V, T _A = 25 °C				8.5	17	μA	
Low power dissipation mode ^{Note 9}			V _{DD} = 3.0 V ± 10 %	3.5	12	μA	
			V _{DD} = 3.0 V, T _A = 25 °C	3.5	7	μA	
I _{DD5}	XT1 = 0 V STOP mode ^{Note 10}	V _{DD} = 5.0 V ± 10 %		0.05	10	μA	
		V _{DD} = 3.0 V ± 10 %		0.02	5	μA	
		T _A = 25 °C		0.02	3	μA	

- Notes**
1. Either R_{LCD1} or R_{LCD2} can be selected by mask option.
 2. Voltage deviation is the difference between the ideal values (V_{LCDn}; n = 0, 1, 2) of the segment and common outputs and the output voltage.
 3. The current flowing through the internal pull-up resistor and the LCD split resistor is not included.
 4. Including the case when the subsystem clock oscillates.
 5. When the device operates in high-speed mode with the processor clock control register (PCC) set to 0011.
 6. When the device operates in low-speed mode with PCC set to 0000.
 7. When the device operates on the subsystem clock, with the system clock control register (SCC) set to 1001 and oscillation of the main system clock stopped.
 - ★ 8. When 0000 is assigned to the sub-oscillator control register (SOS).
 - ★ 9. When 0010 is assigned to the SOS.
 - ★ 10. When the sub-oscillator feedback resistor is not used with the SOS set to 00X1 (X: don't care).

AC Characteristics (T_A = -40 to +85 °C, V_{DD} = 2.2 to 5.5 V)

★

Parameter	Symbol	Conditions		MIN.	TYP.	MAX.	Unit	
CPU clock cycle time ^{Note 1} (minimum instruction execution time = 1 machine cycle)	t _{cy}	Operates with main system clock	When using ceramic or crystal	V _{DD} = 2.7 to 5.5 V	0.67		64	μs
					0.85		64	μs
		When using external clock	V _{DD} = 2.7 to 5.5 V	0.67		64	μs	
			V _{DD} = 1.8 to 5.5 V	0.95		64	μs	
Operates with subsystem clock			114	122	125	μs		
TI0, TI1, TI2 input frequency	f _{TI}	V _{DD} = 2.7 to 5.5 V		0		1	MHz	
				0		275	kHz	
TI0, TI1, TI2 high-, low-level widths	t _{TIH} , t _{TIL}	V _{DD} = 2.7 to 5.5 V		0.48			μs	
				1.8			μs	
Interrupt input high-, low-level widths	t _{INTH} , t _{INTL}	INT0	IM02 = 0	Note 2			μs	
			IM02 = 1	10		μs		
		INT1, 2, 4			10		μs	
		KR0-7			10		μs	
RESET low-level width	t _{RSL}			10			μs	

- Notes 1.** The cycle time of the CPU clock (Φ) is determined by the oscillation frequency of the connected oscillator (and external clock), the system clock control register (SCC), and processor clock control register (PCC). The figure on the right shows the supply voltage V_{DD} vs. cycle time t_{cy} characteristics when the device operates with the main system clock.
- 2.** 2t_{cy} or 128/f_x depending on the setting of the interrupt mode register (IM0).

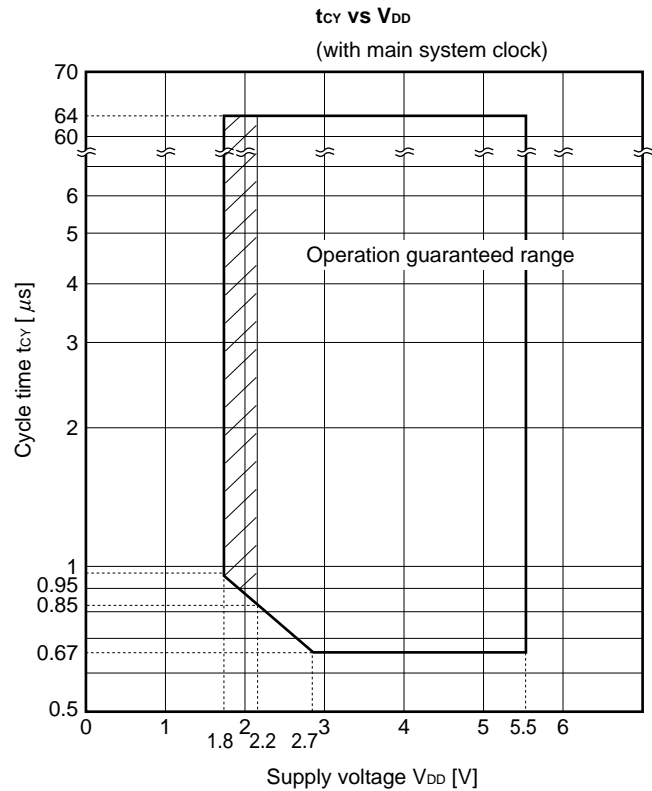

Remark The shaded portion is guaranteed only when using the external clock.

Serial transfer operation

2-wire and 3-wire serial I/O modes ($\overline{\text{SCK}}$... internal clock output): ($T_A = -40$ to $+85$ °C, $V_{DD} = 2.2$ to 5.5 V)

Parameter	Symbol	Conditions	MIN.	TYP.	MAX.	Unit
$\overline{\text{SCK}}$ cycle time	t_{KCY1}	$V_{DD} = 2.7$ to 5.5 V	1300			ns
			3800			ns
$\overline{\text{SCK}}$ high-, low-level widths	$t_{\text{KL1}},$ t_{KH1}	$V_{DD} = 2.7$ to 5.5 V	$t_{\text{KCY1}}/2-50$			ns
			$t_{\text{KCY1}}/2-150$			ns
SI ^{Note 1} setup time (vs. $\overline{\text{SCK}}$ ↑)	t_{SIK1}	$V_{DD} = 2.7$ to 5.5 V	150			ns
			500			ns
SI ^{Note 1} hold time (vs. $\overline{\text{SCK}}$ ↑)	t_{KSI1}	$V_{DD} = 2.7$ to 5.5 V	400			ns
			600			ns
$\overline{\text{SCK}}$ ↓ → SO ^{Note 1} output delay time	t_{KSO1}	$R_L = 1$ kΩ ^{Note 2} $C_L = 100$ pF	$V_{DD} = 2.7$ to 5.5 V		250	ns
				0	1000	ns

- Notes**
1. Replace the parameter with SB0 or SB1 in the 2-wire serial I/O mode.
 2. R_L and C_L respectively indicate the load resistance and load capacitance of the SO output line.

2-wire and 3-wire serial I/O modes ($\overline{\text{SCK}}$... external clock input): ($T_A = -40$ to $+85$ °C, $V_{DD} = 2.2$ to 5.5 V)

Parameter	Symbol	Conditions	MIN.	TYP.	MAX.	Unit
$\overline{\text{SCK}}$ cycle time	t_{KCY2}	$V_{DD} = 2.7$ to 5.5 V	800			ns
			3200			ns
$\overline{\text{SCK}}$ high-, low-level widths	$t_{\text{KL2}},$ t_{KH2}	$V_{DD} = 2.7$ to 5.5 V	400			ns
			1600			ns
SI ^{Note 1} setup time (vs. $\overline{\text{SCK}}$ ↑)	t_{SIK2}	$V_{DD} = 2.7$ to 5.5 V	100			ns
			150			ns
SI ^{Note 1} hold time (vs. $\overline{\text{SCK}}$ ↑)	t_{KSI2}	$V_{DD} = 2.7$ to 5.5 V	400			ns
			600			ns
$\overline{\text{SCK}}$ ↓ → SO ^{Note 1} output delay time	t_{KSO2}	$R_L = 1$ kΩ ^{Note 2} $C_L = 100$ pF	$V_{DD} = 2.7$ to 5.5 V		300	ns
				0	1000	ns

- Notes**
1. Replace the parameter with SB0 or SB1 in the 2-wire serial I/O mode.
 2. R_L and C_L respectively indicate the load resistance and load capacitance of the SO output line.

SBI mode ($\overline{\text{SCK}}$... internal clock output (master)): ($T_A = -40$ to $+85$ °C, $V_{DD} = 2.2$ to 5.5 V)

Parameter	Symbol	Conditions	MIN.	TYP.	MAX.	Unit
$\overline{\text{SCK}}$ cycle time	t_{KCY3}	$V_{DD} = 2.7$ to 5.5 V	1300			ns
			3800			ns
$\overline{\text{SCK}}$ high-, low-level widths	t_{KL3}	$V_{DD} = 2.7$ to 5.5 V	$t_{\text{KCY3}}/2-50$			ns
	t_{KH3}		$t_{\text{KCY3}}/2-150$			ns
SB0, 1 setup time (vs. $\overline{\text{SCK}}$ ↑)	t_{SIK3}	$V_{DD} = 2.7$ to 5.5 V	150			ns
			500			ns
SB0, 1 hold time (vs. $\overline{\text{SCK}}$ ↑)	t_{KSI3}		$t_{\text{KCY3}}/2$			ns
$\overline{\text{SCK}}$ ↓ → SB0, 1 output delay time	t_{KSO3}	$R_L = 1$ kΩ ^{Note} $C_L = 100$ pF	$V_{DD} = 2.7$ to 5.5 V	0	250	ns
				0	1000	ns
$\overline{\text{SCK}}$ ↑ → SB0, 1 ↓	t_{KSB}		t_{KCY3}			ns
SB0, 1 ↓ → $\overline{\text{SCK}}$ ↓	t_{SBK}		t_{KCY3}			ns
SB0, 1 low-level width	t_{SBL}		t_{KCY3}			ns
SB0, 1 high-level width	t_{SBH}		t_{KCY3}			ns

Note R_L and C_L respectively indicate the load resistance and load capacitance of the SB0 and 1 output lines.

SBI mode ($\overline{\text{SCK}}$... external clock input (slave)): ($T_A = -40$ to $+85$ °C, $V_{DD} = 2.2$ to 5.5 V)

Parameter	Symbol	Conditions	MIN.	TYP.	MAX.	Unit
$\overline{\text{SCK}}$ cycle time	t_{KCY4}	$V_{DD} = 2.7$ to 5.5 V	800			ns
			3200			ns
$\overline{\text{SCK}}$ high-, low-level widths	t_{KL4}	$V_{DD} = 2.7$ to 5.5 V	400			ns
	t_{KH4}		1600			ns
SB0, 1 setup time (vs. $\overline{\text{SCK}}$ ↑)	t_{SIK4}	$V_{DD} = 2.7$ to 5.5 V	100			ns
			150			ns
SB0, 1 hold time (vs. $\overline{\text{SCK}}$ ↑)	t_{KSI4}		$t_{\text{KCY4}}/2$			ns
$\overline{\text{SCK}}$ ↓ → SB0, 1 output delay time	t_{KSO4}	$R_L = 1$ kΩ ^{Note} $C_L = 100$ pF	$V_{DD} = 2.7$ to 5.5 V	0	300	ns
				0	1000	ns
$\overline{\text{SCK}}$ ↑ → SB0, 1 ↓	t_{KSB}		t_{KCY4}			ns
SB0, 1 ↓ → $\overline{\text{SCK}}$ ↓	t_{SBK}		t_{KCY4}			ns
SB0, 1 low-level width	t_{SBL}		t_{KCY4}			ns
SB0, 1 high-level width	t_{SBH}		t_{KCY4}			ns

Note R_L and C_L respectively indicate the load resistance and load capacitance of the SB0 and 1 output lines.

★ AC timing test points (except X1 and XT1 inputs)

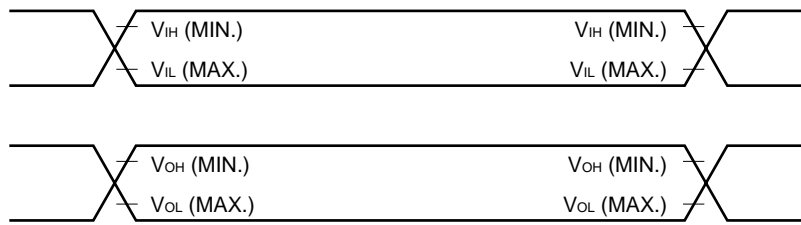

Clock timing

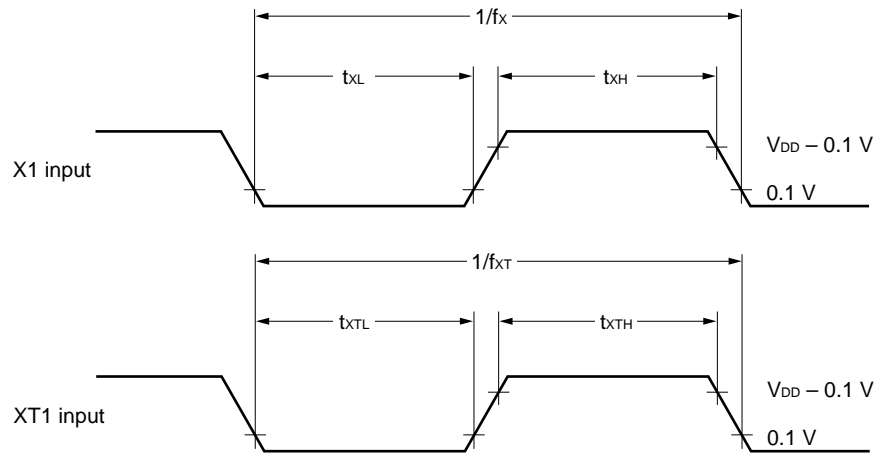

T10, T11, T12 timing

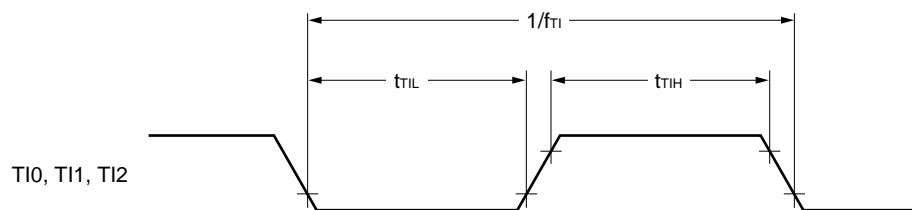

Serial transfer timing

3-wire serial I/O mode

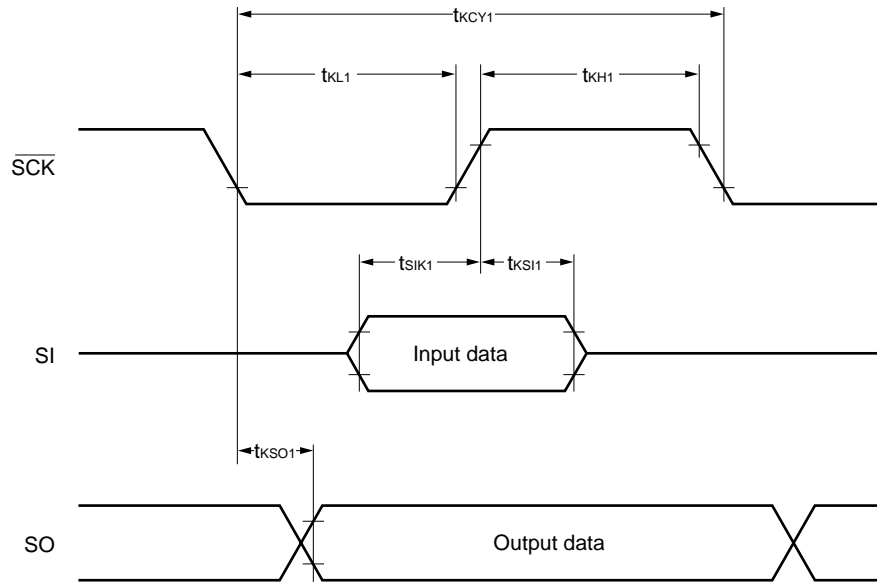

2-wire serial I/O mode

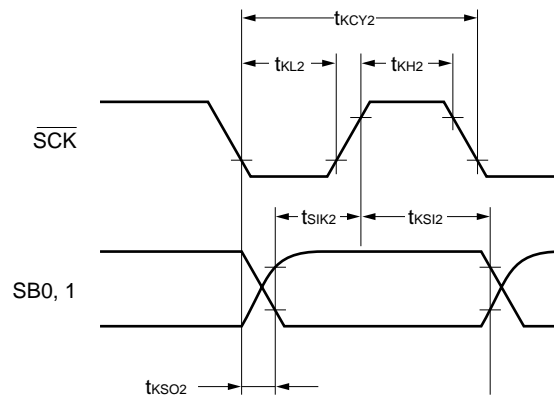

Serial transfer timing

Bus release signal transfer

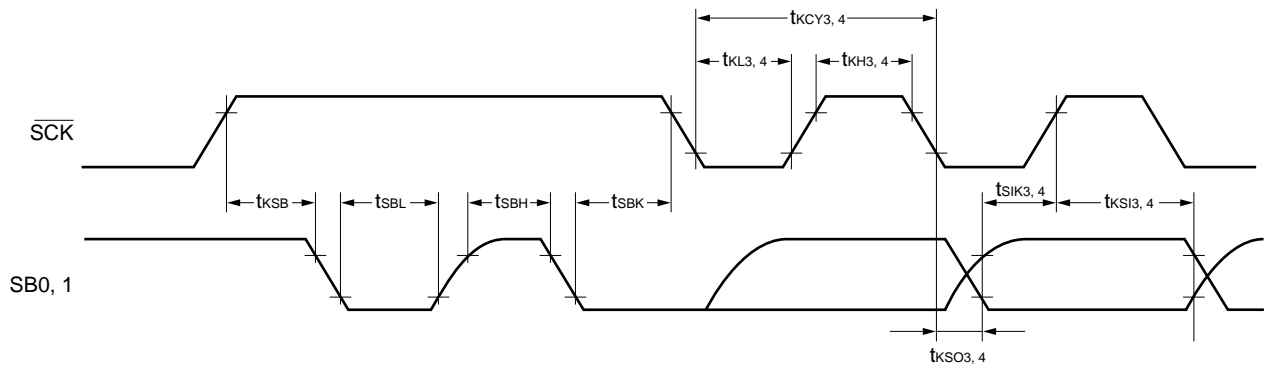

Command signal transfer

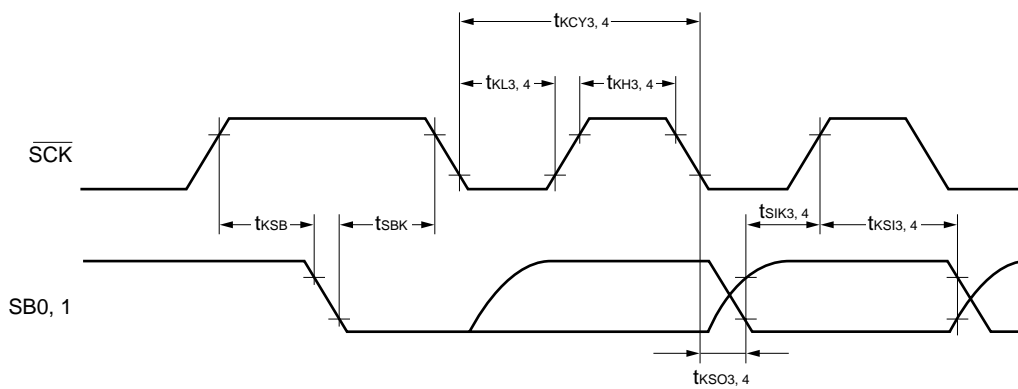

Interrupt input timing

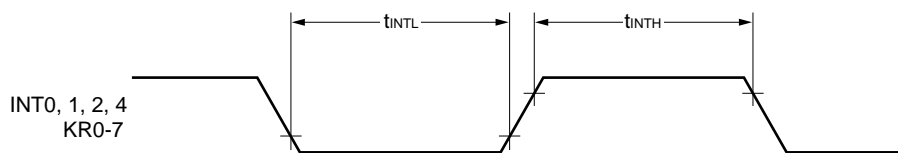

RESET input timing

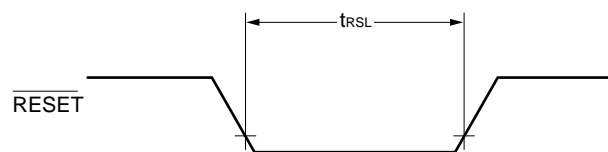

Data retention characteristics of data memory in STOP mode and at low supply voltage
 (T_A = -40 to +85 °C)

Parameter	Symbol	Conditions	MIN.	TYP.	MAX.	Unit
Release signal setup time	t _{SREL}		0			μs
Oscillation stabilization wait time ^{Note 1}	t _{WAIT}	Released by $\overline{\text{RESET}}$		Note 2		ms
		Released by interrupt request		Note 3		ms

- Notes**
1. The oscillation stabilization wait time is the time during which the CPU stops operating to prevent unstable operation when oscillation is started.
 2. Either 2¹⁷/f_x or 2¹⁵/f_x can be selected by mask option.
 3. Set by the basic interval timer mode register (BTM). (Refer to the table below.)

BTM3	BTM2	BTM1	BTM0	Wait Time	
				f _x = 4.19 MHz	f _x = 6.0 MHz
-	0	0	0	2 ²⁰ /f _x (approx. 250 ms)	2 ²⁰ /f _x (approx. 175 ms)
-	0	1	1	2 ¹⁷ /f _x (approx. 31.3 ms)	2 ¹⁷ /f _x (approx. 21.8 ms)
-	1	0	1	2 ¹⁵ /f _x (approx. 7.82 ms)	2 ¹⁵ /f _x (approx. 5.46 ms)
-	1	1	1	2 ¹³ /f _x (approx. 1.95 ms)	2 ¹³ /f _x (approx. 1.37 ms)

Data retention timing (when STOP mode released by $\overline{\text{RESET}}$)

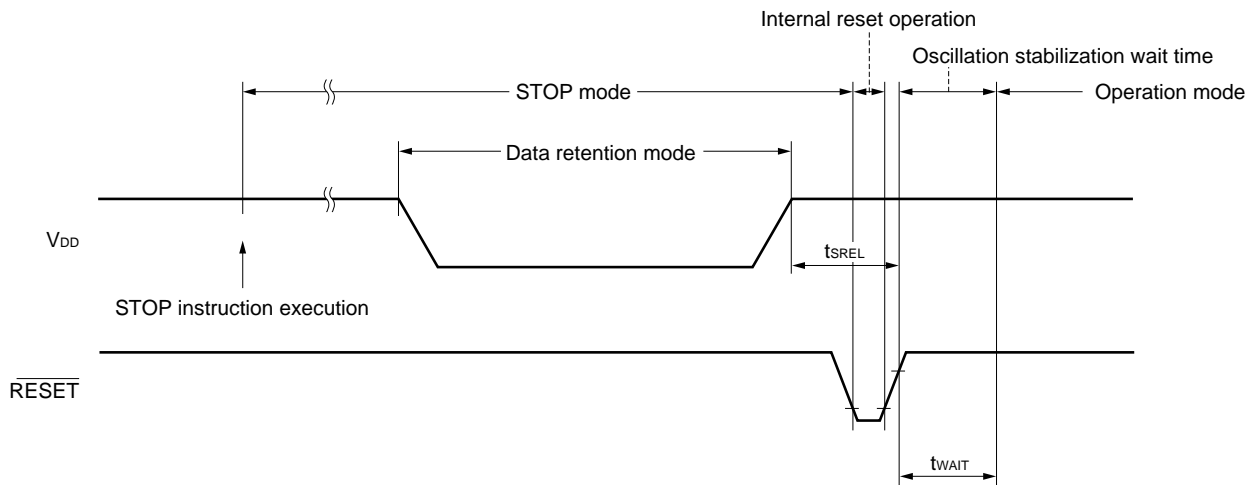

Data retention timing (standby release signal: when STOP mode released by interrupt signal)

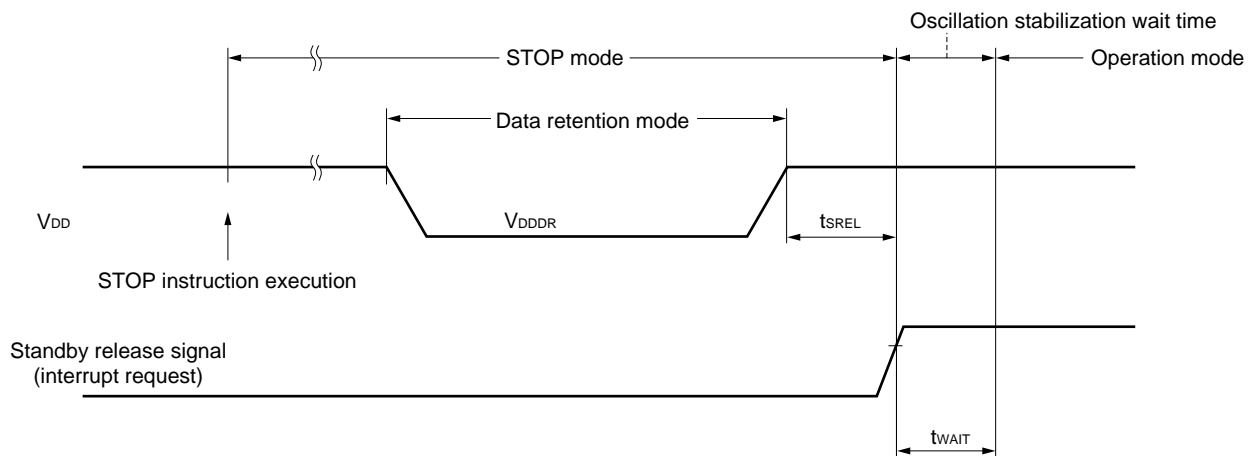

13 . PACKAGE DRAWINGS

80 PIN PLASTIC QFP (14x14)

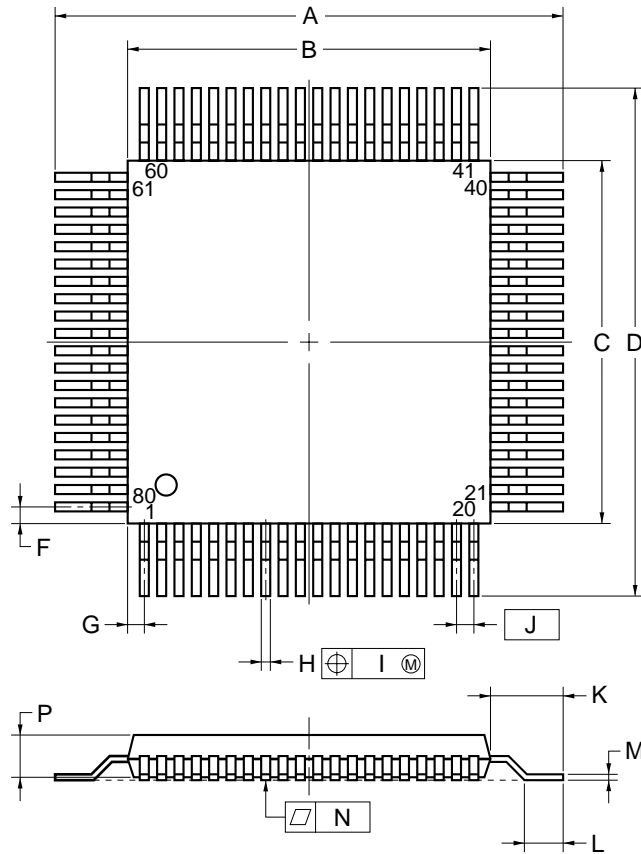

detail of lead end

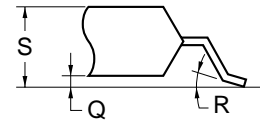

NOTE

Each lead centerline is located within 0.13 mm (0.005 inch) of its true position (T.P.) at maximum material condition.

ITEM	MILLIMETERS	INCHES
A	17.2±0.4	0.677±0.016
B	14.0±0.2	0.551 ^{+0.009} _{-0.008}
C	14.0±0.2	0.551 ^{+0.009} _{-0.008}
D	17.2±0.4	0.677±0.016
F	0.825	0.032
G	0.825	0.032
H	0.30±0.10	0.012 ^{+0.004} _{-0.005}
I	0.13	0.005
J	0.65 (T.P.)	0.026 (T.P.)
K	1.6±0.2	0.063±0.008
L	0.8±0.2	0.031 ^{+0.009} _{-0.008}
M	0.15 ^{+0.10} _{-0.05}	0.006 ^{+0.004} _{-0.003}
N	0.10	0.004
P	2.7±0.1	0.106 ^{+0.005} _{-0.004}
Q	0.1±0.1	0.004±0.004
R	5°±5°	5°±5°
S	3.0 MAX.	0.119 MAX.

S80GC-65-3B9-5

80 PIN PLASTIC TQFP (FINE PITCH) (12×12)

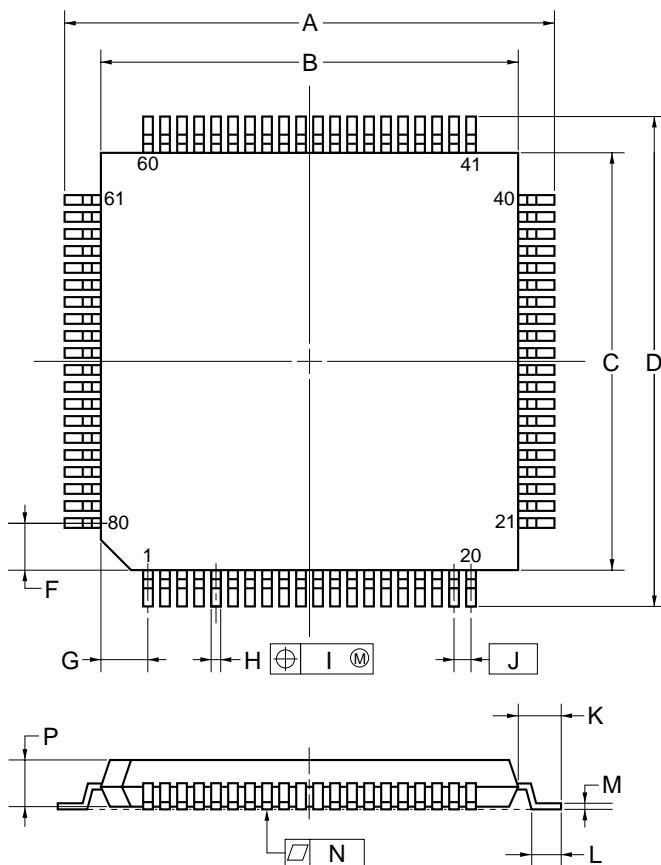

NOTE

Each lead centerline is located within 0.10 mm (0.004 inch) of its true position (T.P.) at maximum material condition.

ITEM	MILLIMETERS	INCHES
A	14.00±0.20	0.551±0.008
B	12.00±0.20	0.472 ^{+0.009} _{-0.008}
C	12.00±0.20	0.472 ^{+0.009} _{-0.008}
D	14.00±0.20	0.551±0.008
F	1.25	0.049
G	1.25	0.049
H	0.22 ^{+0.05} _{-0.04}	0.009±0.002
I	0.10	0.004
J	0.50 (T.P.)	0.020 (T.P.)
K	1.00±0.20	0.039 ^{+0.009} _{-0.008}
L	0.50±0.20	0.020 ^{+0.008} _{-0.009}
M	0.145 ^{+0.055} _{-0.045}	0.006±0.002
N	0.10	0.004
P	1.05	0.041
Q	0.10±0.05	0.004±0.002
R	5°±5°	5°±5°
S	1.27 MAX.	0.050 MAX.

P80GK-50-BE9-5

14. RECOMMENDED SOLDERING CONDITIONS

Solder the μPD753017 under the following recommended conditions.

For the details on the recommended soldering conditions, refer to Information Document **Semiconductor Device Mounting Technology Manual (C10535E)**.

For the soldering methods and conditions other than those recommended, consult NEC.

Table 14-1. Soldering Conditions of Surface Mount Type

(1) μPD753012GC-XXX-3B9: 80-pin plastic QFP (14 × 14 mm)

μPD753016GC-XXX-3B9: 80-pin plastic QFP (14 × 14 mm)

μPD753017GC-XXX-3B9: 80-pin plastic QFP (14 × 14 mm)

Soldering Method	Soldering Conditions	Symbol of Recommended Condition
★ Infrared reflow	Package peak temperature: 235 °C, Time: 30 seconds max. (210 °C min.), Number of times: 3 max.	IR35-00-3
★ VPS	Package peak temperature: 215 °C, Time: 40 seconds max. (200 °C min.), Number of times: 3 max.	VP15-00-3
Wave soldering	Solder bath temperature: 260 °C max., Time: 10 seconds max., Number of times: 1 Preheating temperature: 120 °C max. (package surface temperature)	WS60-00-1
Partial heating	Pin temperature: 300 °C max., Time: 3 seconds max. (per side of device)	–

Caution Do not use two or more soldering methods in combination (except partial heating).

- (2) μPD753012GK-XXX-BE9: 80-pin plastic TQFP (fine pitch) (12 × 12 mm)
- μPD753016GK-XXX-BE9: 80-pin plastic TQFP (fine pitch) (12 × 12 mm)
- μPD753017GK-XXX-BE9: 80-pin plastic TQFP (fine pitch) (12 × 12 mm)

Soldering Method	Soldering Conditions	Symbol of Recommended Condition
Infrared reflow	<p>Package peak temperature: 235 °C, Time: 30 seconds max. (210 °C min.), Number of times: 2 max., Number of days: 7^{Note} (After that, prebaking is necessary at 125 °C for 10 hours.)</p> <p><Precaution> Products other than those packed in heat-resistant trays (such as those packed in a magazine, taping, or non-heat-resistant tray) cannot be baked while they are in their packaging.</p>	IR35-107-2
VPS	<p>Package peak temperature: 215 °C, Time: 40 seconds max. (200 °C min.), Number of times: 2 max., Number of days: 7^{Note} (After that, prebaking is necessary at 125 °C for 10 hours.)</p> <p><Precaution> Products other than those packed in heat-resistant trays (such as those packed in a magazine, taping, or non-heat-resistant tray) cannot be baked while they are in their packaging.</p>	VP15-107-2
Pin partial heating	Pin temperature: 300 °C max., Time: 3 seconds max. (per side of device)	—

Note The number of days for storage after the dry pack has been opened. The storing conditions are 25 °C, 65% RH max.

Caution Do not use two or more soldering methods in combination (except partial heating).

APPENDIX A μPD75316B, 753017 AND 75P3018 FUNCTION LIST

Parameter		μPD75316B	μPD753017	μPD75P3018
Program memory		Mask ROM 0000H-3F7FH (16256 × 8 bits)	Mask ROM 0000H-5FFFH (24576 × 8 bits)	One-time PROM 0000H-7FFFH (32768 × 8 bits)
Data memory		000H-3FFH (1024 × 4 bits)		
CPU		Standard CPU	75XL CPU	
Instruction execution time	When main system clock is selected	0.95, 1.91, 15.3 μs (at 4.19 MHz operation)	<ul style="list-style-type: none"> • 0.95, 1.91, 3.81, 15.3 μs (at 4.19 MHz operation) • 0.67, 1.33, 2.67, 10.7 μs (at 6.0 MHz operation) 	
	When subsystem clock is selected	122 μs (32.768 kHz operation)		
Pin connection	44	P12/INT2	P12/INT2/TI1/TI2	
	47	P21	P21/PTO1	
	48	P22/PCL	P22/PCL/PTO2	
	50-53	P30-P33		P30/MD0-P33/MD3
	57	IC		V _{PP}
Stack	SBS register	None	SBS.3 = 1: Mk I mode selection SBS.3 = 0: Mk II mode selection	
	Stack area	000H-0FFH	n00H-nFFH (n = 0-3)	
	Subroutine call instruction stack operation	2-byte stack	Mk I mode: 2-byte stack Mk II mode: 3-byte stack	
Instruction	BRA !addr1 CALLA !addr1	Unavailable	Mk I mode: unavailable Mk II mode: available	
	MOVT XA, @BCDE MOVT XA, @BCXA BR BCDE BR BCXA		Available	
	CALL !addr	3 machine cycles	Mk I mode: 3 machine cycles, Mk II mode: 4 machine cycles	
	CALLF !faddr	2 machine cycles	Mk I mode: 2 machine cycles, Mk II mode: 3 machine cycles	
Timer		3 channels <ul style="list-style-type: none"> • Basic interval timer: 1 channel • 8-bit timer/event counter: 1 channel • Watch timer: 1 channel 	5 channels <ul style="list-style-type: none"> • Basic interval timer/watchdog timer: 1 channel • 8-bit timer/event counter: 3 channels (can be used as 16-bit timer/event counter, carrier generator, or timer with gate) • Watch timer: 1 channel 	

Parameter		μPD75316B	μPD753017	μPD75P3018
Clock output (PCL)		Φ, 524, 262, 65.5 kHz (Main system clock: at 4.19 MHz operation)	<ul style="list-style-type: none"> • Φ, 524, 262, 65.5 kHz (Main system clock: at 4.19 MHz operation) • Φ, 750, 375, 93.8 kHz (Main system clock: at 6.0 MHz operation) 	
BUZ output		2 kHz (Main system clock: at 4.19 MHz operation)	<ul style="list-style-type: none"> • 2, 4, 32 kHz (Main system clock: at 4.19 MHz operation or subsystem clock: at 32.768 kHz operation) • 2.93, 5.86, 46.9 kHz (Main system clock: at 6.0 MHz operation) 	
Serial interface		3 modes are available <ul style="list-style-type: none"> • 3-wire serial I/O mode ... MSB/LSB can be selected for transfer top bit • 2-wire serial I/O mode • SBI mode 		
SOS register	Feedback resistor cut flag (SOS.0)	None	Provided	
	Sub-oscillator current cut flag (SOS.1)	None	Provided	
Register bank selection register (RBS)		None	Yes	
Standby release by INT0		No	Yes	
Vectored interrupt		External: 3, internal: 3	External: 3, internal: 5	
Supply voltage		V _{DD} = 2.0 to 6.0 V	V _{DD} = 2.2 to 5.5 V	
Operation ambient temperature		T _A = -40 to +85°C		
Package		<ul style="list-style-type: none"> • 80-pin plastic TQFP (fine pitch) (12 × 12 mm) • 80-pin plastic QFP (14 × 14 mm) 		

★

APPENDIX B DEVELOPMENT TOOLS

The following development tools are provided for system development using the μPD753017. The 75XL series uses a common relocatable assembler, in combination with a device file matching each machine.

Language processor

★	RA75X relocatable assembler	Host Machine	OS	Distribution media	Part Number (product name)
		PC-9800 series	MS-DOS™ (Ver. 3.30 to Ver. 6.2 ^{Note})	3.5-inch 2HD	μS5A13RA75X
				5-inch 2HD	μS5A10RA75X
		IBM PC/AT™ and compatible machines	Refer to OS for IBM PC	3.5-inch 2HC	μS7B13RA75X
				5-inch 2HC	μS7B10RA75X

★	Device file	Host Machine	OS	Distribution media	Part Number (product name)
		PC-9800 series	MS-DOS™ (Ver. 3.30 to Ver. 6.2 ^{Note})	3.5-inch 2HD	μS5A13DF753017
				5-inch 2HD	μS5A10DF753017
		IBM PC/AT and compatible machines	Refer to OS for IBM PC	3.5-inch 2HC	μS7B13DF753017
				5-inch 2HC	μS7B10DF753017

Note Ver. 5.00 and later have the task swap function, but cannot be used for this software.

Remark The operation of the assembler and device file is guaranteed only on the above host machines and OSs.

PROM write tools

Hardware	PG-1500	PG-1500 is a PROM programmer which enables you to program single chip microcomputers containing PROM by stand-alone or host machine operation by connecting an attached board and optional programmer adapter to PG-1500. It also enables you to program typical PROM devices of 256K bits to 4M bits.			
	PA-75P316BGC	PROM programmer adapter for μPD75P3018GC. Connect the programmer adapter to PG-1500 for use.			
	PA-75P316BGK	PROM programmer adapter for μPD75P3018GK. Connect the programmer adapter to PG-1500 for use.			
Software	PG-1500 controller	PG-1500 and a host machine are connected by serial and parallel interfaces and PG-1500 is controlled on the host machine.			
		Host machine	OS	Distribution media	Part number (product name)
		PC-9800 series	MS-DOS (Ver. 3.30 to Ver. 6.2 ^{Note})	3.5-inch 2HD	μS5A13PG1500
				5-inch 2HD	μS5A10PG1500
		IBM PC/AT and compatible machines	Refer to OS for IBM PC	3.5-inch 2HC	μS7B13PG1500
5-inch 2HC	μS7B10PG1500				

★

Note Ver.5.00 and later have the task swap function, but it cannot be used for this software.

Remark The operation of the PG-1500 controller is guaranteed only on the above host machines and OSs.

Debugging tool

The in-circuit emulators (IE-75000-R and IE-75001-R) are available as the program debugging tool for the μPD753017.

The system configurations are described as follows.

★	Hardware	IE-75000-R ^{Note 1}	In-circuit emulator for debugging the hardware and software when developing the application systems that use the 75X series and 75XL series. When developing a μPD753017 subseries, the emulation board IE-75300-R-EM and emulation probe that are sold separately must be used with the IE-75000-R. By connecting with the host machine and the PROM programmer, efficient debugging can be made. It contains the emulation board IE-75000-R-EM which is connected.			
		IE-75001-R	In-circuit emulator for debugging the hardware and software when developing the application systems that use the 75X series and 75XL series. When developing a μPD753017 sub-series, the emulation board IE-75300-R-EM and emulation probe which are sold separately must be used with the IE-75001-R. It can debug the system efficiently by connecting the host machine and PROM programmer.			
		IE-75300-R-EM	Emulation board for evaluating the application systems that use the μPD753017 subseries. It must be used with the IE-75000-R or IE-75001-R.			
		EP-753017GC-R	Emulation probe for the μPD753017GC. It must be connected to IE-75000-R (or IE-75001-R) and IE-75300-R-EM. It is supplied with the 80-pin conversion socket EV-9200GC-80 which facilitates connection to a target system.			
		EV-9200GC-80				
★		EP-753017GK-R	Emulation probe for the μPD753017GK. It must be connected to the IE-75000-R (or IE-75001-R) and IE-75300-R-EM. It is supplied with the 80-pin conversion adapter TGK-080SDW which facilitates connection to a target system.			
		TGK-080SDW ^{Note 2}				
★	Software	IE control program	Connects the IE-75000-R or IE-75001-R to a host machine via RS-232-C and Centronix I/F and controls the above hardware on a host machine.			
			Host machine	OS	Distribution media	Part number (product name)
			PC-9800 series	MS-DOS	3.5-inch 2HD	μS5A13IE75X
				(Ver. 3.30 to Ver. 6.2 ^{Note 3})	5-inch 2HD	μS5A10IE75X
			IBM PC/AT and its compatible machines	Refer to OS for IBM PC	3.5-inch 2HC	μS7B13IE75X
5-inch 2HC	μS7B10IE75X					

Notes 1. Maintenance parts

★ 2. This is a product of Tokyo Eletech Corp. (Tokyo 03-5295-1661)

When purchasing this product, consult your NEC distributor.

3. Ver.5.00 and later have the task swap function, but it cannot be used for this software.

Remark The operation of the IE control program is guaranteed only on the above host machines and OSs.

OS for IBM PC

The following IBM PC OS's are supported.

OS	Version
PC DOST™	Ver. 3.1 to Ver. 6.3 J6.1/V ^{Note} to J6.3/V ^{Note}
MS-DOS	Ver. 5.0 to Ver. 6.22 5.0/V ^{Note} to 6.2/V ^{Note}
IBM DOS™	J5.02/V ^{Note}

Note Only English version is supported.

Caution Ver. 5.0 and later have the task swap function, but it cannot be used for this software.

APPENDIX C RELATED DOCUMENTS

Some of the following related documents are preliminary.

Device Related Documents

Document Name	Document No.	
	Japanese	English
μPD753012, 753016, 753017 Data Sheet	U10140J	U10140E (This manual)
μPD75P3018 Data Sheet	U10956J	U10956E
μPD753017 User's Manual	U11282J	U11282E
μPD753017 Instruction	IEM-5598	—
75XL Series Selection Guide	U10453J	U10453E

Development Tool Related Documents

Document Name			Document No.	
			Japanese	English
Hardware	IE-75000 R/IE-75001-R User's Manual		EEU-846	EEU-1416
	IE-75300-R-EM User's Manual		U11354J	U11354E
	EP-753017GC/GK-R User's Manual		EEU-967	EEU-1494
	PG-1500 User's Manual		U11940J	U11940E
Software	RA75X Assembler Package User's Manual	Operation	U12622J	EEU-1346
		Language	U12385J	EEU-1363
	PG-1500 Controller User's Manual	PC-9800 Series (MS-DOS) Base	EEU-704	EEU-1291
		IBM PC Series (PC DOS) Base	EEU-5008	U10540E

Other Documents

Document Name	Document No.	
	Japanese	English
IC Package Manual	C10943X	
Semiconductor Device Mounting Technology Manual	C10535J	C10535E
Quality Grades on NEC Semiconductor Devices	C11531J	C11531E
NEC Semiconductor Device Reliability/Quality Control System	C10983J	C10983E
Guide to Prevent Damage for Semiconductor Devices by Electrostatic Discharge (ESD)	C11892J	C11892E
Semiconductor Devices Quality Guarantee Guide	C11893J	MEI-1202
Guide for Products Related to Microcomputer : Other Companies	U11416J	—

Caution The above related documents are subject to change without notice. For design purpose, etc., be sure to use the latest documents.

NOTES FOR CMOS DEVICES

① PRECAUTION AGAINST ESD FOR SEMICONDUCTORS

Note: Strong electric field, when exposed to a MOS device, can cause destruction of the gate oxide and ultimately degrade the device operation. Steps must be taken to stop generation of static electricity as much as possible, and quickly dissipate it once, when it has occurred. Environmental control must be adequate. When it is dry, humidifier should be used. It is recommended to avoid using insulators that easily build static electricity. Semiconductor devices must be stored and transported in an anti-static container, static shielding bag or conductive material. All test and measurement tools including work bench and floor should be grounded. The operator should be grounded using wrist strap. Semiconductor devices must not be touched with bare hands. Similar precautions need to be taken for PW boards with semiconductor devices on it.

② HANDLING OF UNUSED INPUT PINS FOR CMOS

Note: No connection for CMOS device inputs can be cause of malfunction. If no connection is provided to the input pins, it is possible that an internal input level may be generated due to noise, etc., hence causing malfunction. CMOS device behave differently than Bipolar or NMOS devices. Input levels of CMOS devices must be fixed high or low by using a pull-up or pull-down circuitry. Each unused pin should be connected to V_{DD} or GND with a resistor, if it is considered to have a possibility of being an output pin. All handling related to the unused pins must be judged device by device and related specifications governing the devices.

③ STATUS BEFORE INITIALIZATION OF MOS DEVICES

Note: Power-on does not necessarily define initial status of MOS device. Production process of MOS does not define the initial operation status of the device. Immediately after the power source is turned ON, the devices with reset function have not yet been initialized. Hence, power-on does not guarantee out-pin levels, I/O settings or contents of registers. Device is not initialized until the reset signal is received. Reset operation must be executed immediately after power-on for devices having reset function.

MS-DOS is either a registered trademark or a trademark of Microsoft Corporation in the United States and/or other countries.

IBM DOS, PC/AT and PC DOS are trademarks of IBM Corporation.

The export of this product from Japan is regulated by the Japanese government. To export this product may be prohibited without governmental license, the need for which must be judged by the customer. The export or re-export of this product from a country other than Japan may also be prohibited without a license from that country. Please call an NEC sales representative.

No part of this document may be copied or reproduced in any form or by any means without the prior written consent of NEC Corporation. NEC Corporation assumes no responsibility for any errors which may appear in this document.

NEC Corporation does not assume any liability for infringement of patents, copyrights or other intellectual property rights of third parties by or arising from use of a device described herein or any other liability arising from use of such device. No license, either express, implied or otherwise, is granted under any patents, copyrights or other intellectual property rights of NEC Corporation or others.

While NEC Corporation has been making continuous effort to enhance the reliability of its semiconductor devices, the possibility of defects cannot be eliminated entirely. To minimize risks of damage or injury to persons or property arising from a defect in an NEC semiconductor device, customers must incorporate sufficient safety measures in its design, such as redundancy, fire-containment, and anti-failure features.

NEC devices are classified into the following three quality grades:

"Standard", "Special", and "Specific". The Specific quality grade applies only to devices developed based on a customer designated "quality assurance program" for a specific application. The recommended applications of a device depend on its quality grade, as indicated below. Customers must check the quality grade of each device before using it in a particular application.

Standard: Computers, office equipment, communications equipment, test and measurement equipment, audio and visual equipment, home electronic appliances, machine tools, personal electronic equipment and industrial robots

Special: Transportation equipment (automobiles, trains, ships, etc.), traffic control systems, anti-disaster systems, anti-crime systems, safety equipment and medical equipment (not specifically designed for life support)

Specific: Aircrafts, aerospace equipment, submersible repeaters, nuclear reactor control systems, life support systems or medical equipment for life support, etc.

The quality grade of NEC devices is "Standard" unless otherwise specified in NEC's Data Sheets or Data Books. If customers intend to use NEC devices for applications other than those specified for Standard quality grade, they should contact an NEC sales representative in advance.

Anti-radioactive design is not implemented in this product.