



SD4590

RF POWER TRANSISTORS 800-960 MHz CELLULAR BASE STATION

- √ GOLD METALLIZATION
- √ DIFFUSED EMITTER BALLASTING
- √ INTERNAL INPUT/OUTPUT MATCHING
- √ COMMON EMITTER CONFIGURATION
- √ DESIGNED FOR LINEAR OPERATION HIGH SATURATED POWER CAPABILITY 26 VOLT, 900 MHz PERFORMANCE
- √ $P_{OUT} = 150$ W MIN.
GAIN = 8.5 dB MIN.
IMD₃ = -28dB MAX. @ $P_{OUT} = 150$ W PEP
- √ INHERENT RUGGEDNESS:
LOAD MISMATCH TOLERANCE OF 5:1 MIN. VSWR
3 dB OVERDRIVE CAPABILITY
- √ ESD SENSITIVITY, CLASS 3 (MIL STD-883D METHOD 3015)

DESCRIPTION

The SD4590 is designed for both analog and digital cellular base stations over the 800 to 960 MHz frequency range, specifically those systems requiring the high linearity and efficiency afforded by class AB operation. Integrated input/output pre-matching simplifies amplifier design. Ruggedness, MTTF, and linearity are enhanced using diffused emitter resistors and refractory/gold metallization.

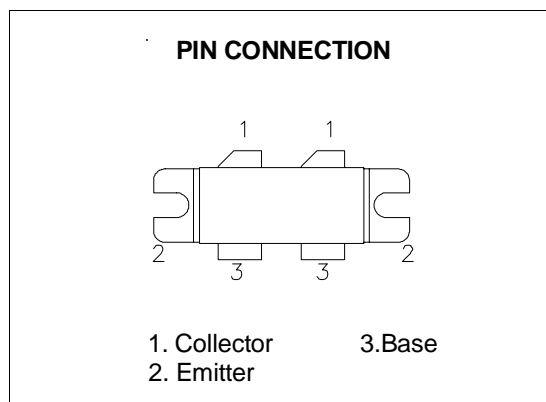
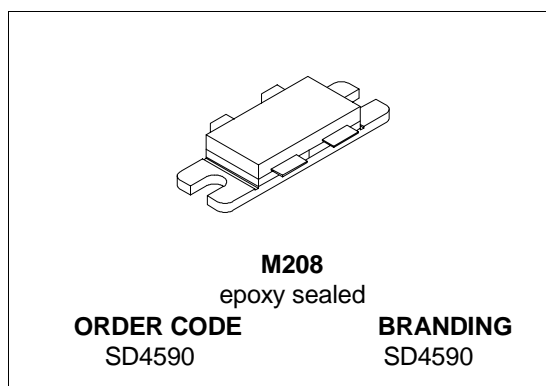

ABSOLUTE MAXIMUM RATINGS ($T_{case} = 25$ °C)

Symbol	Parameter	Value	Unit
V_{CBO}	Collector-Base Voltage	65	V
V_{CEO}	Collector-Emitter Voltage	28	V
V_{EBO}	Emitter-Base Voltage	3.5	V
I_C	Device Current	25	A
P_{DISS}	Power Dissipation	300	W
T_j	Max. Operating Junction Temperature	200	°C
T_{STG}	Storage Temperature	-65 to 150	°C

THERMAL DATA

$R_{th(j-c)}$	Junction-Case Thermal Resistance	0.60	°C/W
---------------	----------------------------------	------	------

SD4590

ELECTRICAL SPECIFICATION (T_{case} = 25 °C)

STATIC

Symbol	Parameter		Min.	Typ.	Max.	Unit
BV _{CB0}	I _C = 100 mA	V _{BE} = 0 V	65	80		V
BV _{CEO}	I _C = 100 mA	I _B = 0 mA	28	30		V
BV _{CER}	I _C = 100 mA	R _{BE} = 80 Ω	33	40		V
BV _{EBO}	I _C = 50 mA	I _C = 0 mA	3.5	4.0		V
I _{CEO}	V _{CE} = 26 V	V _{BE} = 0 V			10	mA
I _{CEO}	V _{CE} = 10 V	V _{BE} = 0 V			0.5	mA
I _{EBO}	V _{BE} = 1 V	V _{CE} = 0 V			0.1	mA
I _{EBO}	V _{BE} = 2.5V	V _{CE} = 0 V			3	mA
h _{FE}	V _{CE} = 5V	I _C = 6 A	25	45	120	

TESTED PER SIDE

REF 1016365E

DYNAMIC

Symbol	Parameter		Min.	Typ.	Max.	Unit
C _{OB}	f = 1 MHz	V _{CB} = 26 V for information only - this part is collector matched		75		pF

DYNAMIC (CW)

Symbol	Parameter				Min.	Typ.	Max.	Unit
P _{IN}	f = 900 MHz	V _{CE} = 26 V	I _{CQ} = 2x200 mA	P _{OUT} = 150 W			21	W
P _{OUT}	f = 900 MHz	V _{CE} = 26 V	I _{CQ} = 2x200 mA	P _{IN} = 21 W	150	175		W
G _P	f = 900 MHz	V _{CE} = 26 V	I _{CQ} = 2x200 mA	P _{OUT} = 150 W	8.5	9.5		dB
η _C	f = 900 MHz	V _{CE} = 26 V	I _{CQ} = 2x200 mA	P _{OUT} = 150 W	50	55		%
P _{1dB}	f = 900 MHz	V _{CE} = 26 V	I _{CQ} = 2x200 mA		150	160		W
OVD	f = 900 MHz	V _{CE} = 26 V	I _{CQ} = 2x200 mA	Set P _{OUT} = 150 W PEP; Increase P _{IN} 3dB	No Degratation in Device Performance			

DYNAMIC (Two-Tone)

Symbol	Parameter			Min.	Typ.	Max.	Unit
*G _P	V _{CE} = 26 V	I _{CQ} = 2x200 mA	P _{OUT} = 150 W PEP	8.5	9.5		dB
*η _C	V _{CE} = 26 V	I _{CQ} = 2x200 mA	P _{OUT} = 150 W PEP	30	35		%
*IMD ₃	V _{CE} = 26 V	I _{CQ} = 2x200 mA	P _{OUT} = 150 W PEP		-32	-28	dB
*Load Mismatch	V _{CE} = 26 V	I _{CQ} = 2x200 mA	P _{OUT} = 150 W PEP VSWR = 5:1 MIN @ All Phase Angles	No Degratation in Device Performance			
*OVD	V _{CE} = 26 V	I _{CQ} = 2x200 mA	Set P _{OUT} = 150 W PEP; Increase P _{IN} 3dB	No Degratation in Device Performance			

Note : f₁ = 900.00 MHz
f₂ = 900.10 MHz

TYPICAL PERFORMANCE

Output Power vs Input Power

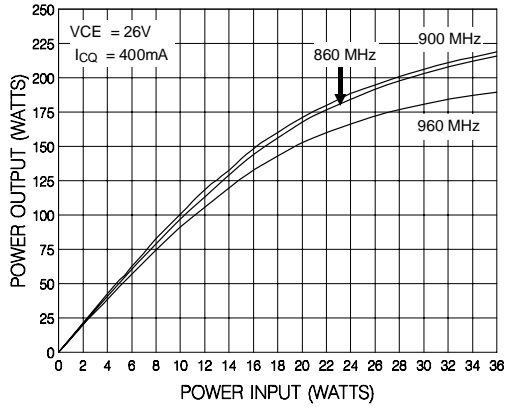

Output Power vs Frequency

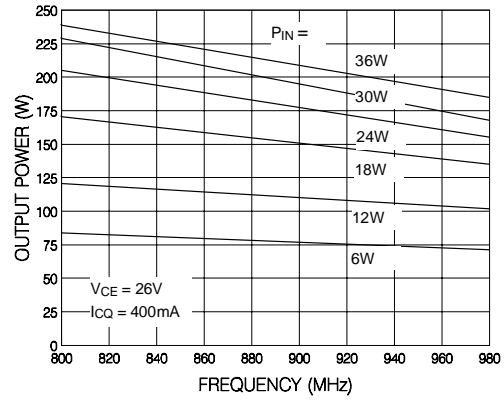

Output Power vs Supply Voltage

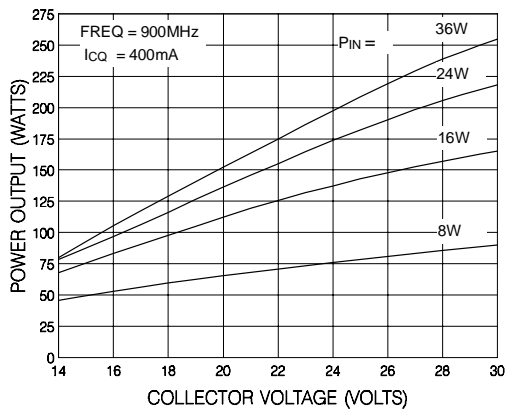

Intermodulation Distortion vs Output Power

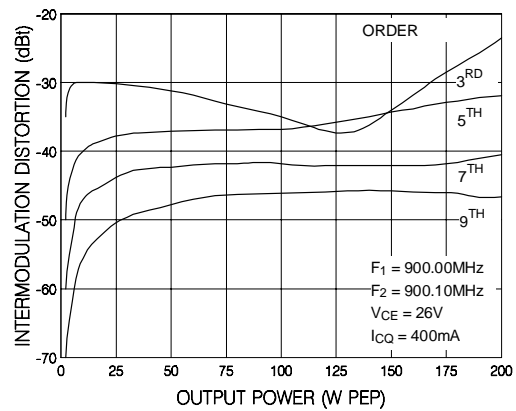

Power Gain vs Output Power

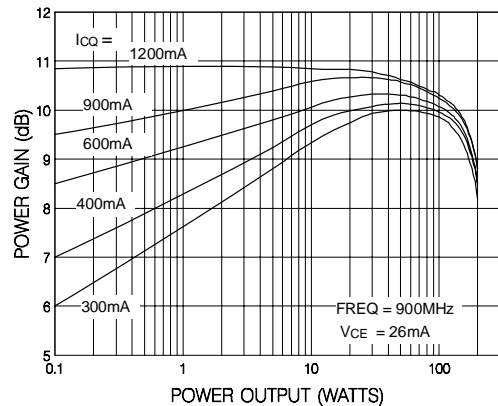

Broadband Performance

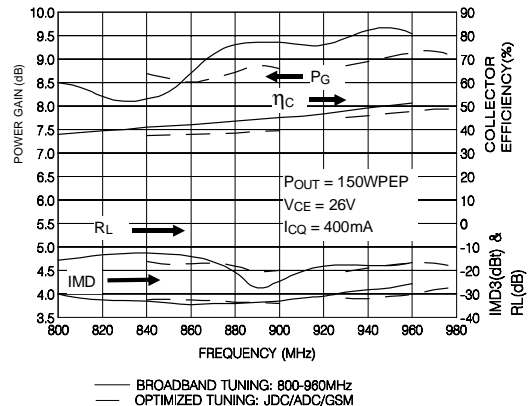

SERIES EQUIVALENT INPUT/OUTPUT IMPEDANCES

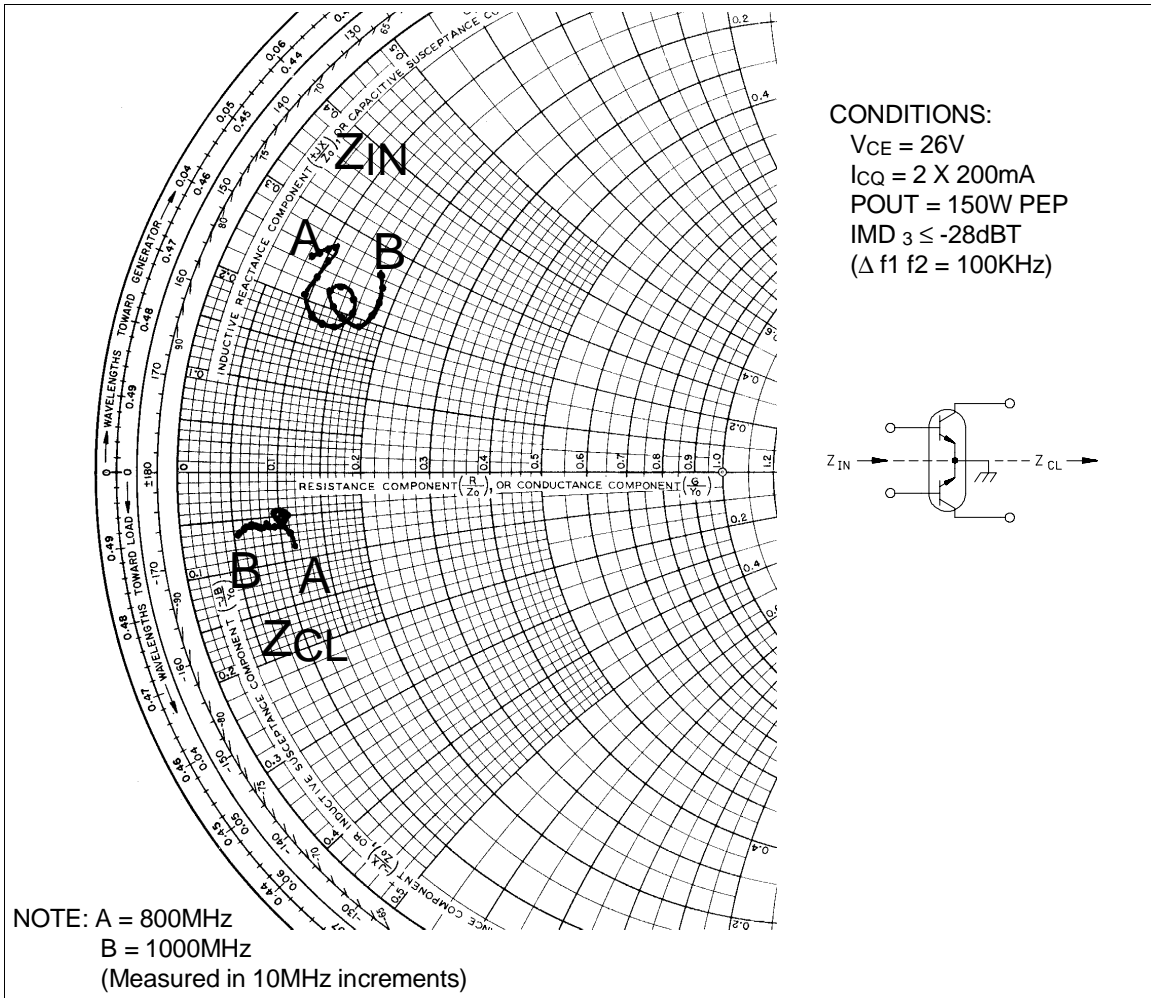

FREQ.	Z _{IN} (Ω)	Z _{CL} (Ω)
800 MHz	4.25 + j 12.25	5.75 - j 4.25
820 MHz	4.75 + j 13.25	5.00 - j 2.75
840 MHz	5.25 + j 12.50	5.50 - j 2.50
860 MHz	4.75 + j 10.25	5.00 - j 3.00
880 MHz	6.25 + j 9.00	4.60 - j 2.90
900 MHz	7.75 + j 10.25	4.25 - j 2.90
920 MHz	6.50 + j 11.50	3.95 - j 2.90
940 MHz	6.50 + j 10.25	3.80 - j 2.80
960 MHz	8.50 + j 9.50	3.40 - j 2.85
980 MHz	9.25 + j 11.50	3.10 - j 3.00
1000 MHz	8.50 + j 13.25	2.75 - j 3.15

TEST CIRCUIT SCHEMATIC

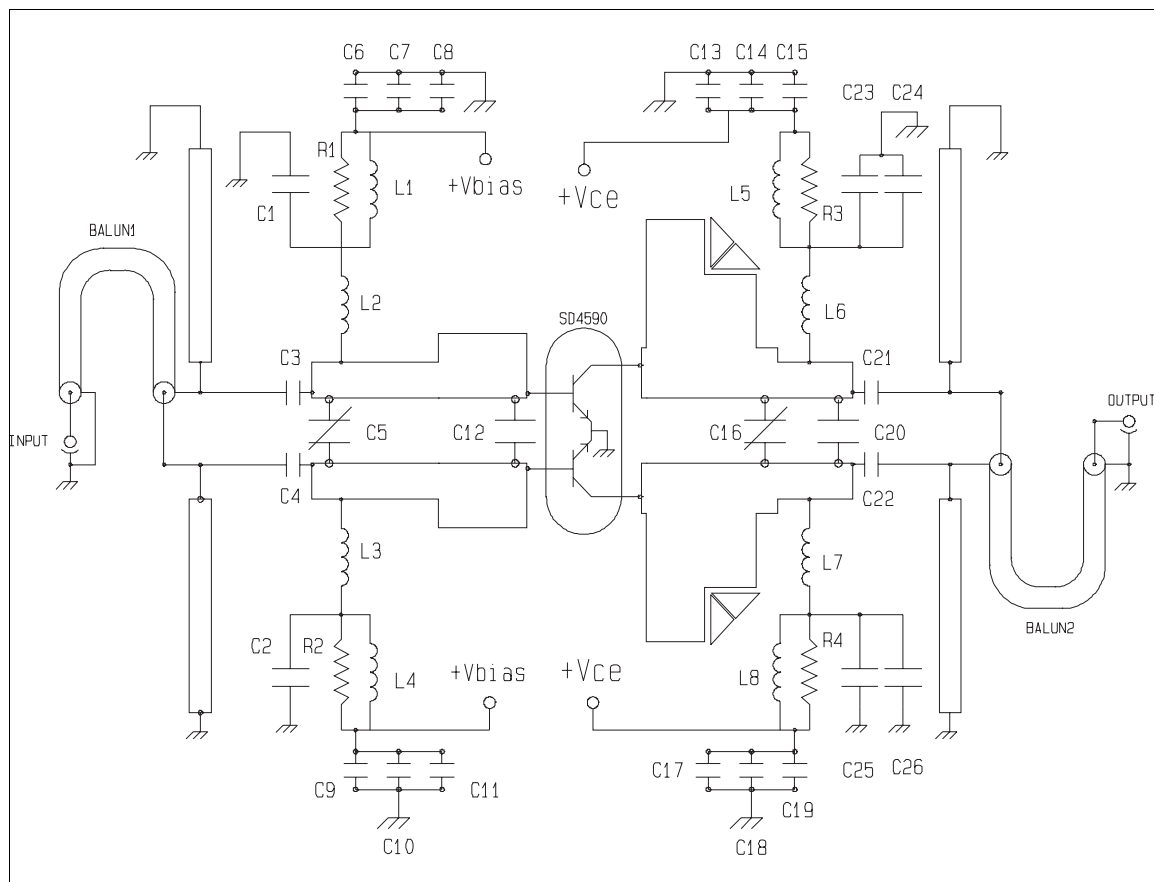

TEST CIRCUIT COMPONENT PART LIST

PCB	ROGERS, $\epsilon_r = 2.55$, Height = 31.25 mil 1 oz. Cu.
Balun 1,2	50 Ω Coaxial Cable Lenght 2.2" attached to 2 x 50 Ω printed microstrip transmission lines (see photomaster)
C1, C2, C23, C25	75pF Ceramic Chip ATC B
C3, C4, C21, C22	2 x 47pF Ceramic Chip, ATC B
C5, C16	0.8 - 8pF Variable, JOHANSON Giga - Trim
C6, C9	750pF Ceramic Chip, ATC B
C7, C10	39nF Ceramic Chip, ATCB
C8, C11, C24, C26	47 μ F, 50V Electrolytic
C13, C17	100 μ F, 50V Electrolytic
C12	9.1pF, Ceramic Chip, ATC A
C14, C18	39nF Ceramic Chip (OPTIONAL)
C15, C19	750pF Ceramic Chip (OPTIONAL)
C20	1.3pF Ceramic Chip, ATC B
L1, L4, L5, L8	12 Turns, #200 AWG, 0.15" I.D. (Tight)
L2, L3, L6, L7	4 Turns, #20AWG, 0.13" I.D. (1:1)
R1, R2, R3, R4	5 X 50 Ω Chip Resistor

TEST CIRCUIT PHOTOMASTER

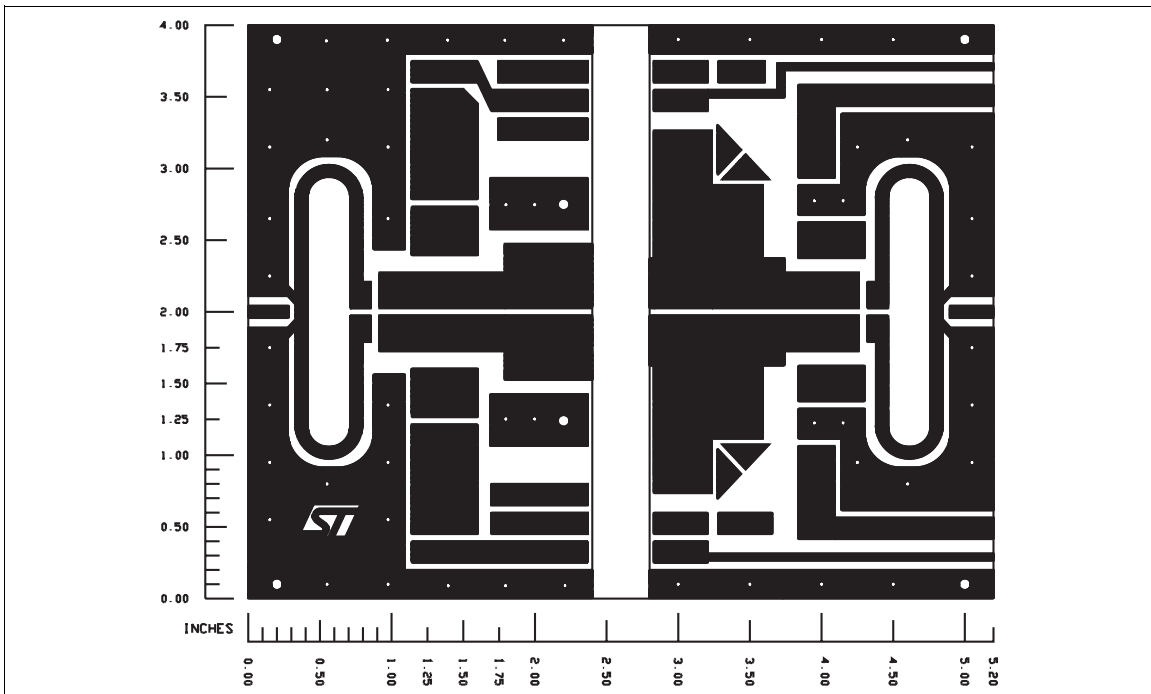

M 208 (.400 X .860 WIDE 2/L N/HERM W/FLG) MECHANICAL DATA

DIM.	mm			inch		
	MIN.	TYP.	MAX.	MIN.	TYP.	MAX.
A	5.59		5.84	.200		.230
B		5.33			.210	
C	3.05		3.30	.120		.130
D	9.65		9.91	.380		.390
E	19.81		20.83	.780		.820
F		11.05			.435	
G		27.94			1.100	
H	33.91		34.16	1.335		1.345
I	0.08		0.18	.003		.007
J	1.52		1.78	.060		.070
K	2.08		2.54	.082		.100
L			5.21			.205
M	10.03		10.34	.395		.407
N	21.59		22.10	.850		.870

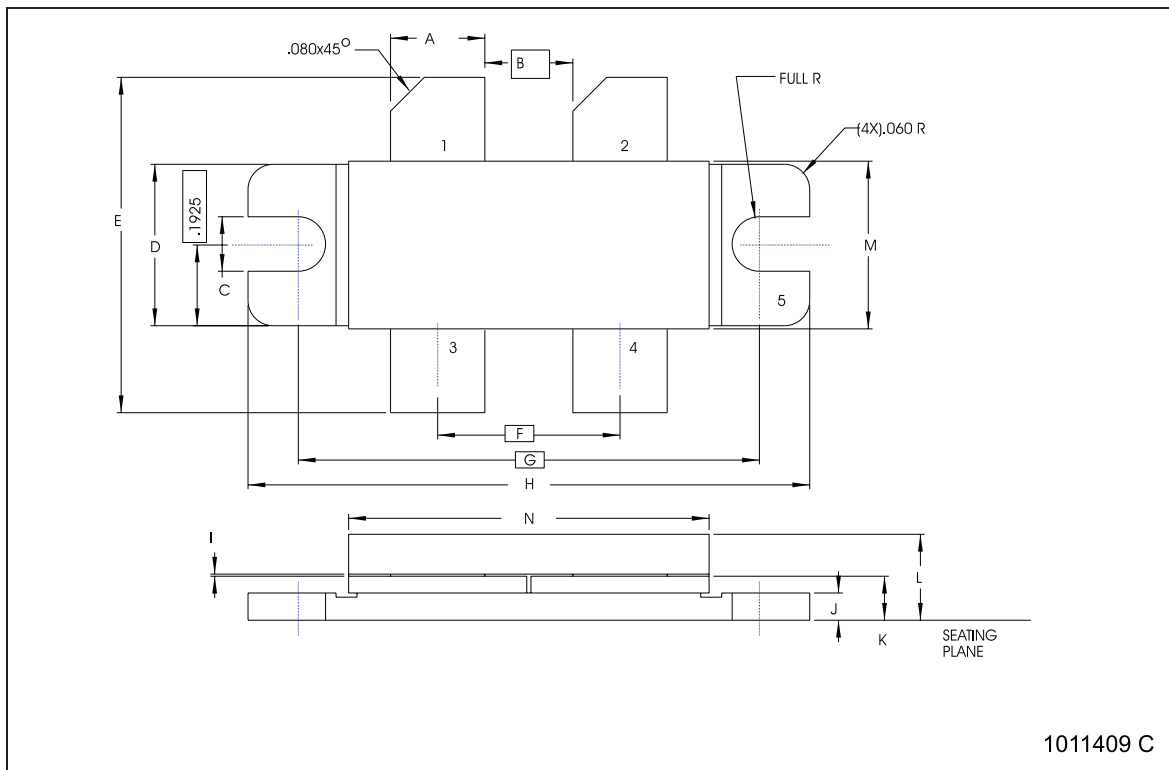

Information furnished is believed to be accurate and reliable. However, STMicroelectronics assumes no responsibility for the consequences of use of such information nor for any infringement of patents or other rights of third parties which may result from its use. No license is granted by implication or otherwise under any patent or patent rights of STMicroelectronics. Specification mentioned in this publication are subject to change without notice. This publication supersedes and replaces all information previously supplied. STMicroelectronics products are not authorized for use as critical components in life support devices or systems without express written approval of STMicroelectronics.

The ST logo is a trademark of STMicroelectronics

© 2000 STMicroelectronics – Printed in Italy – All Rights Reserved
STMicroelectronics GROUP OF COMPANIES

Australia - Brazil - China - Finland - France - Germany - Hong Kong - India - Italy - Japan - Malaysia - Malta - Morocco -
Singapore - Spain - Sweden - Switzerland - United Kingdom - U.S.A.

<http://www.st.com>