

**DALLAS**  
SEMICONDUCTOR

## DS1804 NV Trimmer Potentiometer

### FEATURES

- Single 100-Position Linear Taper Potentiometer
- Nonvolatile "On-Demand" Wiper Storage
- Operates from 3V or 5V supplies
- Up/Down, Increment Controlled Interface
- Resistance Values: 10K $\Omega$ , 50K $\Omega$ , and 100K $\Omega$
- Available in 8-Pin (300 Mil) DIP, 8-Pin (150 Mil) SOIC packages
- Operating Temperature:
  - Commercial: 0°C to 70°C
  - Industrial: -40°C to 85°C

### PIN ASSIGNMENT

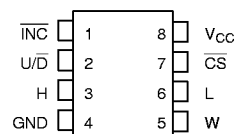

8-PIN DIP (300 MIL)  
8-PIN SOIC (150 MIL)

See Mech. Drawings  
Section

### PIN DESCRIPTION

H	– High-End of Resistor
L	– Low-End of Resistor
W	– Wiper Terminal
$V_{CC}$	– 3V or 5V Power Supply Input
$\overline{\text{CS}}$	– Chip Select
$\overline{\text{U/D}}$	– Up/Down Control Input
$\overline{\text{INC}}$	– Increment/Decrement Counter Input
GND	– Ground

### DESCRIPTION

The DS1804 is a nonvolatile digital potentiometer having 100 positions. The device provides an ideal method for low-cost trimming applications using a CPU or manual control input with minimal external circuitry. Wiper position of the DS1804 can be stored in EEPROM memory on demand. The device's wiper position is manipulated by a 3-terminal port that provides an increment/decrement counter controlled interface. This port consist of the control inputs  $\overline{\text{CS}}$ ,  $\overline{\text{INC}}$ , and  $\overline{\text{U/D}}$ .

The DS1804 is available in three resistor grades which include a 10K $\Omega$ , 50K $\Omega$ , and 100K $\Omega$ . Commercial and industrial versions of the device are available. Additionally, the DS1804 will operate from 3V or 5V supplies and is ideal for portable application requirements. Two packaging options are available and include the 8-pin (300 mil) DIP and 8-Pin (150 mil) SOIC.

## OPERATION

The DS1804 is a single nonvolatile potentiometer. The device has a total of 100 tap-points including the L- and H- terminals. A total of 99 resistive segments exist between the L- and H- terminals. These tap-points are accessible to the W-terminal whose position is controlled via a 3-terminal control port. A block diagram of the DS1804 is shown in Figure 1.

The 3-terminal port of the DS1804 provides an increment/decrement interface which is activated via a chip select input. This interface consists of the input signals  $\overline{CS}$ ,  $\overline{INC}$ , and  $U/\overline{D}$ . These input signals control a 7-bit up/down counter. The output of the 7-bit up/down counter controls a 1 of 100 decoder to select wiper position. Additionally, this interface provides for a wiper storage operation using the  $\overline{CS}$  and  $\overline{INC}$  input control pins. The timing diagram for the 3-terminal interface control is shown in Figure 2.

## PIN DESCRIPTIONS

**V<sub>CC</sub>** – Power Supply Terminal. The DS1804 will support supply voltages ranging from +2.7 to +5.5 volts.

**GND** – Ground Terminal.

**H** – High-end of Resistor. This is the high-end terminal of the potentiometer. It is not required that this terminal be connected to a potential greater than the L-terminal. Voltage applied to the H-terminal can not exceed the power-supply voltage,  $V_{CC}$ , or go below ground.

**L** – Low-end of Resistor – This is the low-end terminal of the potentiometer. It is not required that this terminal be connected to a potential less than the H-terminal. Voltage applied to the L-terminal cannot exceed the power-supply voltage,  $V_{CC}$ , or go below ground.

**W** – Wiper of the Potentiometer. This pin is the wiper terminal of the potentiometer. Its position on the resistor array is controlled by the 3-terminal control port. Voltage applied to the W-terminal cannot exceed the power-supply voltage,  $V_{CC}$ , or go below ground.

**$\overline{CS}$**  – Chip Select. The  $\overline{CS}$  input is used to activate the control port of the DS1804. This input is active low. When in a high-state, activity on the  $\overline{INC}$  and  $U/\overline{D}$  port pins will not affect or change wiper position.

**$\overline{INC}$**  – Wiper Movement Control. This input provides for wiper position changes when the  $\overline{CS}$  pin is low. Wiper position changes of the W-terminal will occur one position per high-to-low transition of this input signal. Position changes will not occur if the  $\overline{CS}$  pin is in a high-state.

**$U/\overline{D}$**  – Up/Down Control. This input sets the direction of wiper movement. When in a high-state and  $\overline{CS}$  is low, any high-to-low transition on  $\overline{INC}$  will cause a one position movement of the wiper towards the H-terminal. When in a low-state and  $\overline{CS}$  is low, any high-to-low transitions on  $\overline{INC}$  will cause the position of the wiper to move towards the L-terminal.

**DS1804 BLOCK DIAGRAM** Figure 1

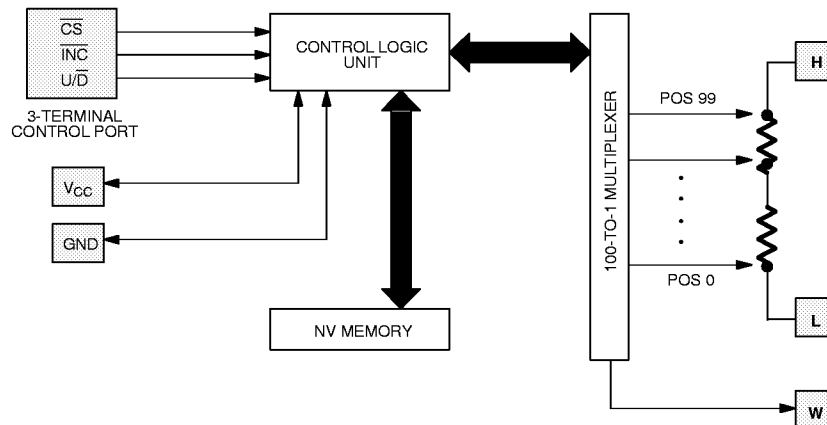

### POWER-UP/POWER-DOWN CONDITIONS

On power-up the DS1804 will load the value of EEPROM memory into the wiper position register (or 1 of 100 decoder). The value of this register can then be set to another wiper position if desired, by using the 3-terminal control port. On power-up, wiper position will be loaded within a maximum time period of 500  $\mu$ s once the power-supply is stable. Additionally, the 3-terminal interface port will be active after 50 ms.

On power-down, the wiper position register data will be lost. On the next device power-up, the value of EEPROM memory will be loaded into the wiper position register.

On shipment from the factory, Dallas Semiconductor does not guarantee a specified EEPROM memory value. This value should be set by the customer as needed. The next section discusses wiper storage operation for the DS1804.

### NONVOLATILE WIPER STORAGE

Wiper position of the DS1804 can be stored using the  $\overline{\text{INC}}$  and  $\overline{\text{CS}}$  inputs. Storage of the wiper position takes place, whenever the  $\overline{\text{CS}}$  input transitions from low-to-

high while the  $\overline{\text{INC}}$  is high. Once this condition has occurred the value of the current wiper position will be written to EEPROM memory.

The DS1804 is specified to accept 50,000 writes to EEPROM before a wear-out condition. After wearout the DS1804 will still function and wiper position can be changed during powered conditions using the 3-terminal control port. However, on power-up the wiper position will be indeterminate.

### ONE TIME PROGRAMMABILITY (OTP)

The DS1804 can be easily used as an OTP device. The user of the DS1804 can trim the desired value of the wiper position and set this position for storage as described above. Any activity through the 3-terminal port can then be prevented by connecting the  $\overline{\text{CS}}$  input pin to  $V_{\text{CC}}$ . Also, an OTP application does not adversely affect the number of times EEPROM is written, since EEPROM will only be loaded and *not written* during a power-up or power-down condition.

On power-up the DS1804 will load the current value of EEPROM memory into the wiper position register.

**ABSOLUTE MAXIMUM RATINGS\***

Voltage on Any Pin Relative to Ground	-1.0V to +7.0V
Operating Temperature	0°C to 70°C; commercial -40°C to +85°C; industrial
Storage Temperature	-55°C to +125°C
Soldering Temperature	260°C for 10 seconds

\* This is a stress rating only and functional operation of the device at these or any other conditions above those indicated in the operation sections of this specification is not implied. Exposure to absolute maximum rating conditions for extended periods of time may affect reliability.

**RECOMMENDED DC OPERATING CONDITIONS**

(-40°C to +85°C)

PARAMETER	SYMBOL	MIN	TYP	MAX	UNITS	NOTES
Supply Voltage	V <sub>CC</sub>	+2.7		5.5	V	1
Input Logic 1	V <sub>IH</sub>	2.0		V <sub>CC</sub> +0.5	V	1, 2
Input Logic 0	V <sub>IL</sub>	-0.5		+0.8 +0.6	V	1, 15
Resistor Inputs	L, H, W	GND-0.5		V <sub>CC</sub> +0.5	V	1, 3

**DC ELECTRICAL CHARACTERISTICS**(-40°C to +85°C; V<sub>CC</sub>=2.7V to 5.5V)

PARAMETER	SYMBOL	MIN	TYP	MAX	UNITS	NOTES
Supply Current	I <sub>CC</sub>			400	μA	4
Input Leakage	I <sub>LI</sub>	-1		+1	μA	
Wiper Resistance	R <sub>W</sub>		400	1000	Ω	
Wiper Current	I <sub>W</sub>			1	mA	
Standby Current 3 Volts 5 Volts	I <sub>STBY</sub>		10 20	40	μA μA	5
Wiper Load Time	t <sub>WLT</sub>		500		μs	6
Power-Up Time	t <sub>PU</sub>		50		ms	14

**ANALOG RESISTOR CHARACTERISTICS**(-40°C to +85°C; V<sub>CC</sub>=2.7V to 5.5V)

PARAMETER	SYMBOL	MIN	TYP	MAX	UNITS	NOTES
Total Resistance			10 50 100		KΩ	7
End-to-End Resistor Tolerance		-20		+20	%	8
Absolute Linearity			±0.6		LSB	9
Relative Linearity			±0.25		LSB	10
-3 dB Cutoff Frequency	f <sub>cutoff</sub>				MHz	11
Temperature Coefficient			650		ppm/°C	

**CAPACITANCE**(25°C;  $V_{CC}=2.7V$  to 5.5V)

PARAMETER	SYMBOL	MIN	TYP	MAX	UNITS	NOTES
Input Capacitance	$C_{IN}$			5	pF	12
Output Capacitance	$C_{OUT}$			7	pF	12

**AC ELECTRICAL CHARACTERISTICS**(-40°C to +85°C;  $V_{CC}=2.7V$  to 5.5V)

PARAMETER	SYMBOL	MIN	TYP	MAX	UNITS	NOTES
$\overline{CS}$ to $\overline{INC}$ Setup	$t_{CI}$	50			ns	13
$U/\overline{D}$ to $\overline{INC}$ Setup	$t_{DI}$	100			ns	13
$\overline{INC}$ Low Period	$t_{iL}$	50			ns	13
$\overline{INC}$ High Period	$t_{iH}$	100			ns	13
INC Inactive to $\overline{CS}$ Inactive	$t_{iC}$	500			ns	13
$\overline{CS}$ Deselect Time	$t_{CPH}$	100			ns	13
Wiper Change to $\overline{INC}$ Low	$t_{iW}$			200	ns	13
$\overline{INC}$ Rise and Fall Times	$t_{R}, t_{F}$			500	$\mu s$	13
$\overline{INC}$ Low to $\overline{CS}$ Inactive	$t_{iK}$	50			ns	16
Wiper Storage Time	$t_{WST}$			10	ms	13, 17

**NOTES:**

- All voltages are referenced to ground.
- Valid for  $V_{CC} = 5V$  only.
- Resistor input voltages cannot go below ground or exceed  $V_{CC}$  by the amounts as shown in the table.
- Maximum current specifications are based on the clock rate of  $\overline{INC}$  input. This specification represents the current required when changing the wiper position.
- Standby current levels apply when all inputs are driven to appropriate supply levels.  $\overline{CS}, \overline{INC}, U/\overline{D} = V_{CC}$ .
- Wiper load time is specified as the time required for the DS1804 to load the wiper position with the contents of nonvolatile memory once  $V_{CC}$  has reached a stable operating voltage equal to or greater than 2.7V.
- The DS1804 is available in three resistor values. These include the DS1804-010; 10K $\Omega$ , the DS1804-050 50K $\Omega$ ; and the DS1804-100 100K $\Omega$ .
- The end-to-end resistance tolerance of the DS1804 can be expected to shift with temperature. However, this change will not exceed  $\pm 20\%$  of the nominal resistor value of the part.
- Absolute linearity is used to compare measured wiper voltage versus expected wiper voltage as determined by wiper position. The DS1804 is specified to provide an absolute linearity of  $\pm 0.60$  LSB
- Relative linearity is used to determine the change in voltage between successive tap positions. The DS1804 is specified to provide a relative linearity specification of  $\pm 0.25$  LSB.
- 3 dB cutoff frequency characteristics for the DS1804 depend on potentiometer total resistance. DS1804-010, 1 MHz, DS1804-050; 200 KHz, and DS1804-100; 100 KHz.

12. Capacitance values apply at 25°C.
13. See Figure 2.
14. Power-up time is specified as the time required before the 3-terminal control becomes active after a stable power supply level has been reached.
15. At  $V_{CC} = 2.7V$ ,  $V_{IL} = 0.8V$
16. The  $\overline{INC}$  low to  $\overline{CS}$  inactive is specified to be 50 ns minimum. This is the transition condition which allows the DS1804 3-terminal port to become inactive without writing the EEPROM memory of the part.
17. Wiper Storage Time,  $t_{WST}$ , is the time require for the DS1804 to write EEPROM memory for storage of a new wiper position. The maximum time required to accomplish this task is specified at 10 ms.

### 3-TERMAL INTERFACE TIMING DIAGRAM Figure 2

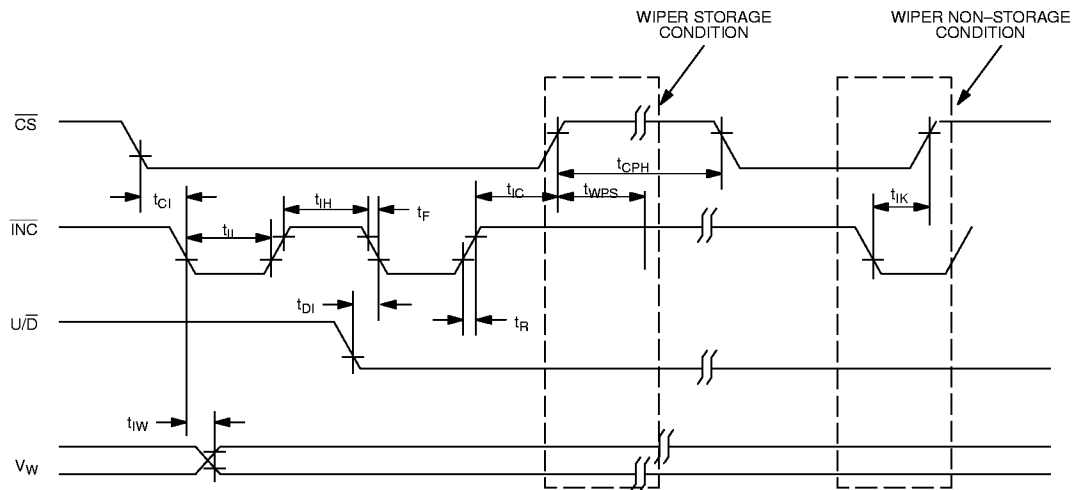

8- TO 28-PIN DIP (300 MIL)

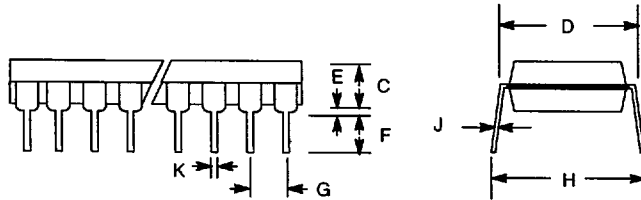
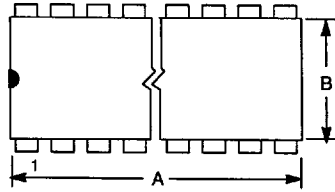

Includes:

- |         |          |         |
|---------|----------|---------|
| DS1000  | DS1211   | DS1621  |
| DS1000M | DS1215   | DS1625  |
| DS1003  | DS1221   | DS1632  |
| DS1003M | DS1222   | DS1640  |
| DS1004M | DS1228   | DS1651  |
| DS1005  | DS1229   | DS1652  |
| DS1005M | DS1231   | DS1652B |
| DS1007  | DS1232   | DS1653  |
| DS1010  | DS1232LP | DS1666  |
| DS1012M | DS1234   | DS1667  |
| DS1013  | DS1236   | DS1669  |
| DS1013M | DS1237   | DS1802  |
| DS1020  | DS1238   | DS1830  |
| DS1033M | DS1239   | DS1832  |
| DS1035M | DS1259   | DS1867  |
| DS1040M | DS1267   | DS1868  |
| DS1044  | DS1275   | DS1869  |
| DS1045  | DS1291   | DS2009D |
| DS1200  | DS1293   | DS2010D |
| DS1206  | DS1336   | DS2011D |
| DS1210  | DS1620   | DS2013D |

PKG	8-PIN		10-PIN		14-PIN		16-PIN	
	MIN	MAX	MIN	MAX	MIN	MAX	MIN	MAX
A IN.	0.360	0.400	0.480	0.520	0.740	0.780	0.740	0.780
MM	9.14	10.16	12.19	13.21	18.80	19.81	18.80	19.81
B IN.	0.240	0.260	0.240	0.260	0.240	0.260	0.240	0.260
MM	6.10	6.60	6.10	6.60	6.10	6.60	6.10	6.60
C IN.	0.120	0.140	0.120	0.140	0.120	0.140	0.120	0.140
MM	3.05	3.56	3.05	3.56	3.05	3.56	3.05	3.56
D IN.	0.300	0.325	0.300	0.325	0.300	0.325	0.300	0.325
MM	7.62	8.26	7.62	8.26	7.62	8.26	7.62	8.26
E IN.	0.015	0.040	0.015	0.040	0.015	0.040	0.015	0.040
MM	0.38	1.02	0.38	1.02	0.38	1.02	0.38	1.02
F IN.	0.120	0.140	0.110	0.130	0.120	0.140	0.120	0.140
MM	3.04	3.56	2.79	3.30	3.04	3.56	3.04	3.56
G IN.	0.090	0.110	0.090	0.110	0.090	0.110	0.090	0.110
MM	2.29	2.79	2.29	2.79	2.29	2.79	2.29	2.79
H IN.	0.320	0.370	0.320	0.370	0.320	0.370	0.320	0.370
MM	8.13	9.40	8.13	9.40	8.13	9.40	8.13	9.40
J IN.	0.008	0.012	0.008	0.012	0.008	0.012	0.008	0.012
MM	0.20	0.30	0.20	0.30	0.20	0.30	0.20	0.30
K IN.	0.015	0.021	0.015	0.021	0.015	0.021	0.015	0.021
MM	0.38	0.53	0.38	0.53	0.38	0.53	0.38	0.53

Continued on following page.

## MECHANICAL DRAWINGS

### 8-, 14-, AND 16-PIN SOIC (.150" BODY WIDTH)

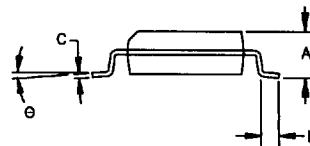
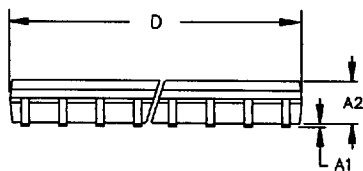
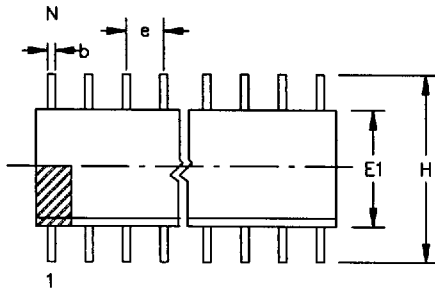

PKG	8-PIN		14-PIN		16-PIN	
	MIN	MAX	MIN	MAX	MIN	MAX
A IN. MM	0.053 1.35	0.069 1.75	0.053 1.35	0.069 1.75	0.053 1.35	0.069 1.75
A1 IN. MM	0.004 0.10	0.010 0.25	0.004 0.10	0.010 0.25	0.004 0.10	0.010 0.25
A2 IN. MM	0.048 1.24	0.062 1.57	0.048 1.24	0.062 1.57	0.048 1.24	0.062 1.57
b IN. MM	0.012 0.30	0.020 0.50	0.012 0.30	0.020 0.50	0.012 0.30	0.020 0.50
C IN. MM	0.007 0.17	0.011 0.28	0.007 0.17	0.011 0.28	0.007 0.17	0.011 0.28
D IN. MM	0.188 4.78	0.196 4.98	0.337 8.55	0.344 8.74	0.386 9.80	0.393 9.98
e IN. MM	0.050 BSC 1.27 BSC		0.050 BSC 1.27 BSC		0.050 BSC 1.27 BSC	
E1 IN. MM	0.150 3.81	0.158 4.01	0.150 3.81	0.158 4.01	0.150 3.81	0.158 4.01
H IN. MM	0.230 5.84	0.244 6.20	0.230 5.84	0.244 6.20	0.230 5.84	0.244 6.20
L IN. MM	0.016 0.40	0.050 0.89	0.016 0.40	0.050 0.89	0.016 0.40	0.050 0.89
θ	0°	8°	0°	8°	0°	8°