

CZTA14 NPN
CZTA64 PNP

SILICON COMPLEMENTARY
DARLINGTON TRANSISTORS

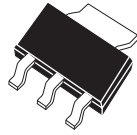

SOT-223 CASE

CentralTM
Semiconductor Corp.

DESCRIPTION:

The CENTRAL SEMICONDUCTOR CZTA14, CZTA64 types are complementary silicon Darlington transistors manufactured by the epitaxial planar process, epoxy molded in a surface mount package, designed for applications requiring extremely high gain.

MARKING CODE: FULL PART NUMBER

MAXIMUM RATINGS: ($T_A=25^\circ\text{C}$)

| | SYMBOL | | UNITS |
|------------------------------|----------------|-------------|--------------------|
| Collector-Base Voltage | V_{CB0} | 30 | V |
| Collector-Emitter Voltage | V_{CEO} | 30 | V |
| Emitter-Base Voltage | V_{EBO} | 10 | V |
| Continuous Collector Current | I_C | 1.0 | A |
| Power Dissipation | P_D | 2.0 | W |
| Operating and Storage | | | |
| Junction Temperature | T_J, T_{stg} | -65 to +150 | $^\circ\text{C}$ |
| Thermal Resistance | θ_{JA} | 62.5 | $^\circ\text{C/W}$ |

ELECTRICAL CHARACTERISTICS: ($T_A=25^\circ\text{C}$ unless otherwise noted)

| SYMBOL | TEST CONDITIONS | MIN | MAX | UNITS |
|---------------|--|--------|-----|-------|
| I_{CBO} | $V_{CB}=30\text{V}$ | | 100 | nA |
| I_{EBO} | $V_{EB}=10\text{V}$ | | 100 | nA |
| BV_{CES} | $I_C=100\mu\text{A}$ | 30 | | V |
| $V_{CE(SAT)}$ | $I_C=100\text{mA}, I_B=0.1\text{mA}$ | | 1.5 | V |
| $V_{BE(ON)}$ | $V_{CE}=5.0\text{V}, I_C=100\text{mA}$ | | 2.0 | V |
| h_{FE} | $V_{CE}=5.0\text{V}, I_C=10\text{mA}$ | 10,000 | | |
| h_{FE} | $V_{CE}=5.0\text{V}, I_C=100\text{mA}$ | 20,000 | | |
| f_T | $V_{CE}=5.0\text{V}, I_C=10\text{mA}, f=100\text{MHz}$ | 125 | | MHz |

R1 (26-September 2002)

SOT-223 CASE - MECHANICAL OUTLINE

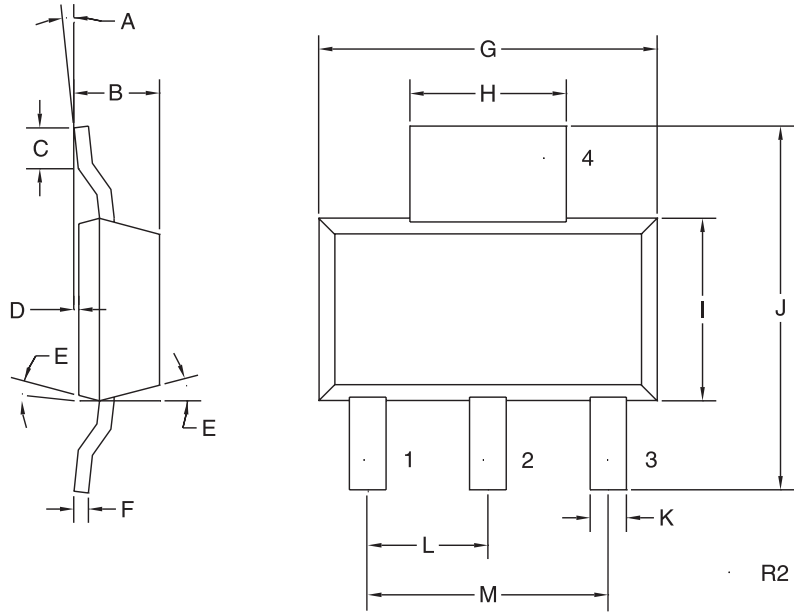

LEAD CODE:

- 1) BASE
- 2) COLLECTOR
- 3) EMITTER
- 4) COLLECTOR

MARKING CODE:

FULL PART NUMBER

| SYMBOL | DIMENSIONS | | | |
|--------|------------|-------|-------------|------|
| | INCHES | | MILLIMETERS | |
| | MIN | MAX | MIN | MAX |
| A | 0° | 7° | 0° | 7° |
| B | 0.063 | 0.067 | 1.60 | 1.70 |
| C | 0.022 | | 0.55 | |
| D | 0.001 | 0.004 | 0.03 | 0.10 |
| E | 15° | | 15° | |
| F | 0.009 | 0.013 | 0.23 | 0.33 |
| G | 0.248 | 0.264 | 6.30 | 6.71 |
| H | 0.114 | 0.122 | 2.90 | 3.10 |
| I | 0.130 | 0.146 | 3.30 | 3.71 |
| J | 0.264 | 0.287 | 6.71 | 7.29 |
| K | 0.024 | 0.031 | 0.61 | 0.79 |
| L | 0.091 | | 2.31 | |
| M | 0.181 | | 4.60 | |

SOT-223 (REV: R2)

R1 (26-September 2002)