**ULTRA-SMALL PACKAGE PWM CONTROL, PWM/PFM
SWITCHING CONTROL STEP-UP SWITCHING REGULATOR**

S-8353/8354 Series

The S-8353/8354 Series is a CMOS step-up switching regulator which mainly consists of a reference voltage source, an oscillation circuit, a power MOS FET, an error amplifier, a phase compensation circuit, a PWM controller (S-8353 Series) and a PWM/PFM switching controller (S-8354 Series).

Simply attaching a coil, capacitor, and diode externally can configure the step-up switching regulator. In addition to the above features, the small package and low power consumption of this series make it ideal for portable device applications requiring high efficiency. The S-8353 Series realizes low ripple, high efficiency, and excellent transient characteristics due to its PWM controller, which can vary the duty ratio linearly from 0 % to 83 % (from 0 % to 78 % for 250 kHz models), optimally-designed error amplifier, and phase compensation circuits.

The S-8354 Series features a PWM/PFM switching controller that can switch the operation to a PFM controller with a duty ratio is 15 % under a light load to prevent a decline in the efficiency due to the IC operating current.

■ Features

- Low voltage operation: Start-up is guaranteed from 0.9 V ($I_{OUT}=1$ mA)
- Low current consumption: During operation: 18.7 μ A (3.3 V, 50 kHz, typ.)
During shutdown: 0.5 μ A (max.)
- Duty ratio: Built-in PWM/PFM switching control circuit (S-8354 Series)
15 % to 83 % (30 kHz and 50 kHz models), 15 % to 78 % (250 kHz models)
- External parts: Coil, capacitor, and diode
- Output voltage: Can be set in 0.1 V steps between 1.5 and 6.5 V (for V_{DD}/V_{OUT} separate types) or 2.0 and 6.5 V (for other than V_{DD}/V_{OUT} separate types). Accuracy of $\pm 2.4\%$.
- Oscillation frequency: 30 kHz, 50 kHz, and 250 kHz
- Soft start function: 6 ms (50 kHz, typ.)

■ Applications

- Power supplies for portable equipment such as digital cameras, electronic notebooks, and PDAs
- Power supplies for audio equipment such as portable CD/MD players
- Constant voltage power supplies for cameras, video equipment, and communications equipment
- Power supplies for microcomputers

■ Packages

Package name	Drawing code		
	Package	Tape	Reel
SOT-23-3	MP003-A	MP003-A	MP003-A
SOT-23-5	MP005-A	MP005-A	MP005-A
SOT-89-3	UP003-A	UP003-A	UP003-A

■ **Block Diagrams**

1. **A, C, H type (Without Shutdown Function)**

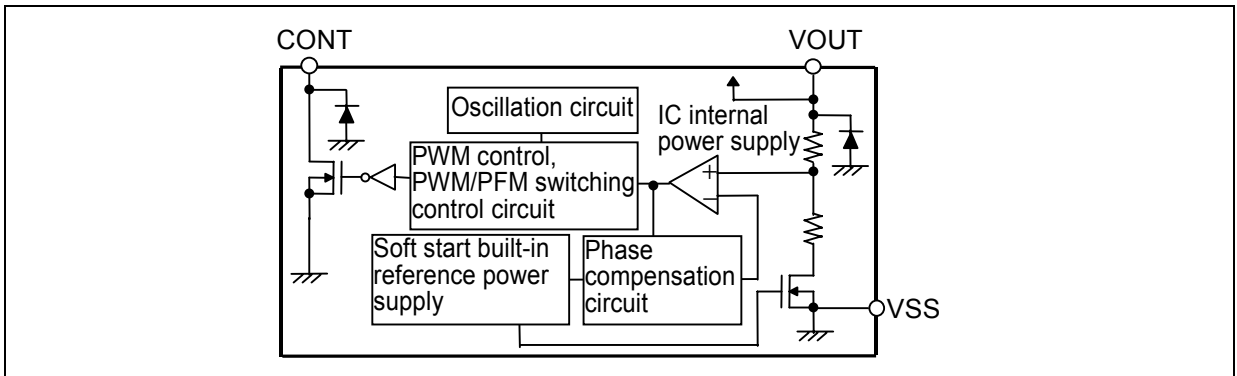

Figure 1

2. **A, H type (With Shutdown Function)**

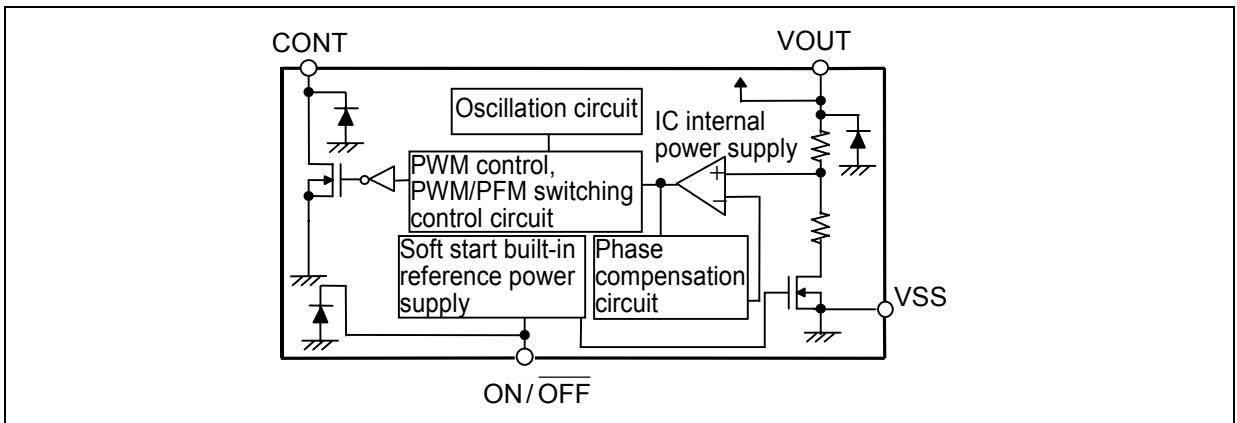

Figure 2

3. **D, J type**

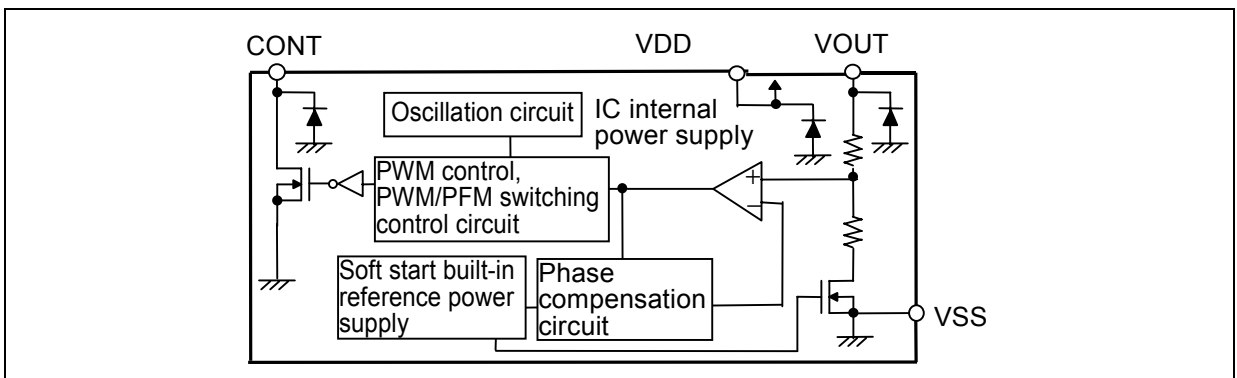

Figure 3

■ **Product Name Structure**

1. **Function List**

Table 1

Product name	Control system	Switching frequency [kHz]	Shutdown function	V _{DD} /V _{OUT} separate type	Package	Application
S-8353AxxMC	PWM	50	Yes	—	SOT-23-5	Application requiring shutdown function
S-8353AxxMA	PWM	50	—	—	SOT-23-3	Application not requiring shutdown function
S-8353AxxUA	PWM	50	—	—	SOT-89-3	Application not requiring shutdown function
S-8353CxxMA	PWM	30	—	—	SOT-23-3	For pager
S-8353DxxMC	PWM	50	—	Yes	SOT-23-5	Application in which output voltage is adjusted by external resistance
S-8353HxxMC	PWM	250	Yes	—	SOT-23-5	Application requiring shutdown function and thin coil
S-8353HxxMA	PWM	250	—	—	SOT-23-3	Application not requiring shutdown function and requiring thin coil
S-8353HxxUA	PWM	250	—	—	SOT-89-3	Application not requiring shutdown function and requiring thin coil
S-8353JxxMC	PWM	250	—	Yes	SOT-23-5	Application in which output voltage is adjusted by external resistance and that requires thin coil
S-8354AxxMC	PWM/PFM switching	50	Yes	—	SOT-23-5	Application requiring shutdown function
S-8354AxxMA	PWM/PFM switching	50	—	—	SOT-23-3	Application not requiring shutdown function
S-8354AxxUA	PWM/PFM switching	50	—	—	SOT-89-3	Application not requiring shutdown function
S-8354CxxMA	PWM/PFM switching	30	—	—	SOT-23-3	For pager
S-8354DxxMC	PWM/PFM switching	50	—	Yes	SOT-23-5	Application in which output voltage is adjusted by external resistance
S-8354HxxMC	PWM/PFM switching	250	Yes	—	SOT-23-5	Application requiring shutdown function and thin coil
S-8354HxxMA	PWM/PFM switching	250	—	—	SOT-23-3	Application not requiring shutdown function and requiring thin coil
S-8354HxxUA	PWM/PFM switching	250	—	—	SOT-89-3	Application not requiring shutdown function and requiring thin coil
S-8354JxxMC	PWM/PFM switching	250	—	Yes	SOT-23-5	Application in which output voltage is adjusted by external resistance and that requires thin coil

2. Product Name

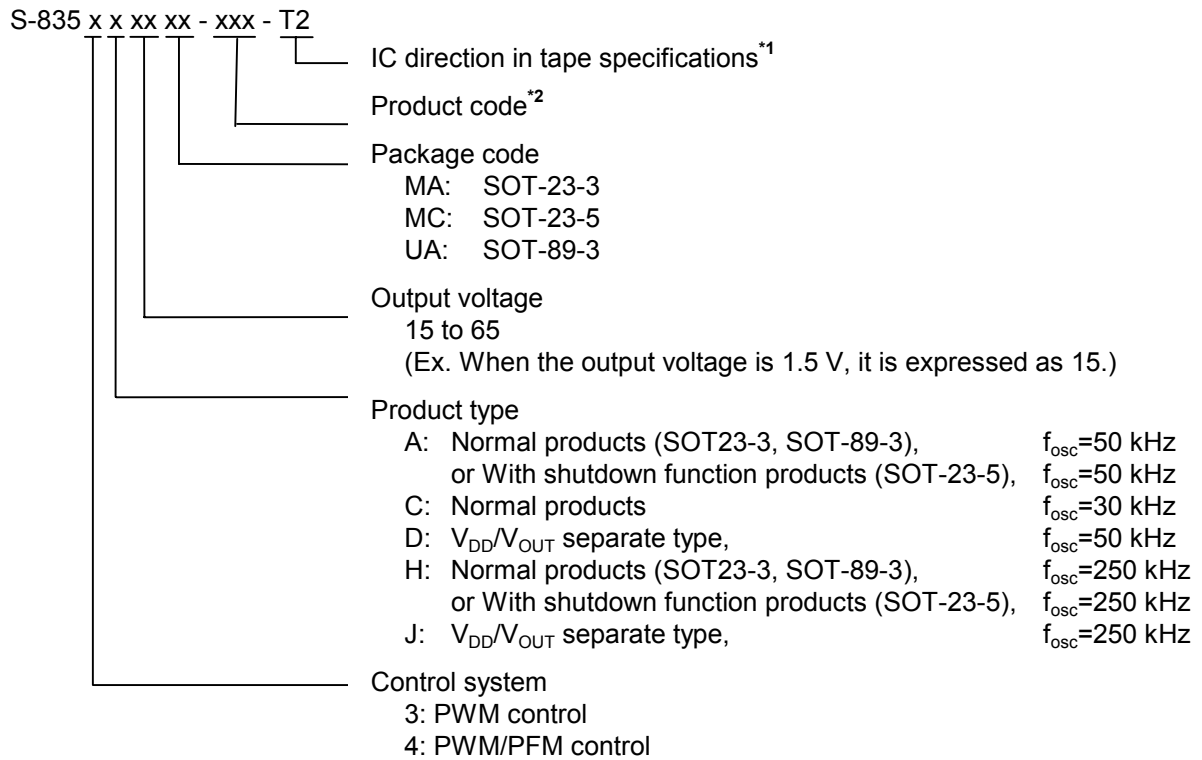

*1. Refer to the taping specifications at the end of this book.

*2. Refer to the “3. Product Name List”.

3. Product Name List

3-1. S-8353 Series

Table 2

Output voltage	S-8353AxxMC Series	S-8353AxxMA Series	S-8353AxxUA Series	S-8353CxxMA Series
2.0 V	S-8353A20MC-IQF-T2	—	—	—
2.5 V	S-8353A25MC-IQK-T2	—	—	—
2.7 V	S-8353A27MC-IQM-T2	—	—	—
2.8 V	S-8353A28MC-IQN-T2	—	—	—
3.0 V	S-8353A30MC-IQP-T2	S-8353A30MA-IQP-T2	—	S-8353C30MA-ISP-T2
3.3 V	S-8353A33MC-IQS-T2	S-8353A33MA-IQS-T2	S-8353A33UA-IQS-T2	—
3.8 V	S-8353A38MC-IQX-T2	—	—	—
5.0 V	S-8353A50MC-IRJ-T2	S-8353A50MA-IRJ-T2	S-8353A50UA-IRJ-T2	—

Remark Please contact the SII marketing department for products with an output voltage other than those specified above.

Table 3

Output voltage	S-8353DxxMC Series	S-8353HxxMC Series	S-8353JxxMC Series
2.0 V	S-8353D20MC-IUF-T2	—	S-8353J20MC-IYF-T2
2.5 V	—	—	S-8353J25MC-IYK-T2
3.0 V	S-8353D30MC-IUP-T2	S-8353H30MC-IWP-T2	—
3.1 V	—	S-8353H31MC-IWQ-T2	—
3.3 V	—	S-8353H33MC-IWS-T2	—
3.8 V	—	S-8353H38MC-IWX-T2	—
4.0 V	—	S-8353H40MC-IWZ-T2	—
4.5 V	—	S-8353H45MC-IXE-T2	—
5.0 V	S-8353D50MC-IVJ-T2	S-8353H50MC-IXJ-T2	S-8353J50MC-IZJ-T2

Remark Please contact the SII marketing department for products with an output voltage other than those specified above.

3-2. S-8354 Series

Table 4

Output voltage	S-8354AxxMC Series	S-8354AxxMA Series	S-8354AxxUA Series	S-8354DxxMC Series
2.0 V	—	—	—	S-8354D20MC-JUF-T2
2.7 V	S-8354A27MC-JQM-T2	S-8354A27MA-JQM-T2	—	—
3.0 V	S-8354A30MC-JQP-T2	S-8354A30MA-JQP-T2	S-8354A30UA-JQP-T2	—
3.3 V	S-8354A33MC-JQS-T2	S-8354A33MA-JQS-T2	S-8354A33UA-JQS-T2	—
4.0 V	S-8354A40MC-JQZ-T2	—	—	—
5.0 V	S-8354A50MC-JRJ-T2	S-8354A50MA-JRJ-T2	S-8354A50UA-JRJ-T2	—

Remark Please contact the SII marketing department for products with an output voltage other than those specified above.

Table 5

Output voltage	S-8354HxxMC Series	S-8354JxxMC Series
3.0 V	S-8354H30MC-JWP-T2	—
3.3 V	S-8354H33MC-JWS-T2	—
5.0 V	S-8354H50MC-JXJ-T2	S-8354J50MC-JZJ-T2

Remark Please contact the SII marketing department for products with an output voltage other than those specified above.

■ **Pin Configurations**

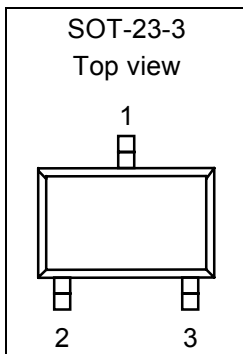

Figure 4

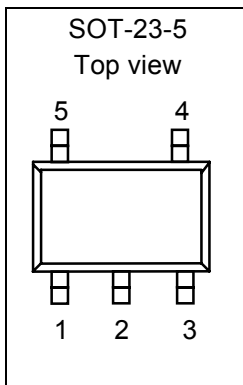

Figure 5

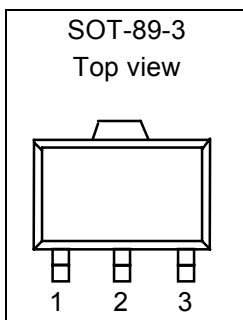

Figure 6

Table 6

Pin No.	Symbol	Pin description
1	VOUT	Output voltage and IC power supply pin
2	VSS	GND pin
3	CONT	External inductor connection pin

Table 7

Pin No.	Symbol	Pin description
1	ON/ $\overline{\text{OFF}}$ (A, H type)	Shutdown pin "H": Normal operation (Step-up operation) "L": Stop step-up (Entire circuit stopped)
	VOUT (D, J type)	Output voltage pin
2	VOUT (A, H type)	Output voltage and IC power supply pin
	VDD (D, J type)	IC power supply pin
3	NC ^{*1}	No connection
4	VSS	GND pin
5	CONT	External inductor connection pin

*1. The NC pin is electrically open.

Table 8

Pin No.	Symbol	Pin description
1	VSS	GND pin
2	VOUT	Output voltage and IC power supply pin
3	CONT	External inductor connection pin

■ **Absolute Maximum Ratings**

Table 9

(Ta=25°C unless otherwise specified)

Item	Symbol	Absolute maximum rating		Unit
VOUT pin voltage	V _{OUT}	V _{SS} -0.3 to V _{SS} +12		V
ON/OFF pin voltage (S-835xAxxMC, S-835xHxxMC)	V _{ON/OFF}	V _{SS} -0.3 to V _{SS} +12		
VDD pin voltage (S-835xDxxMC, S-835xJxxMC)	V _{DD}	V _{SS} -0.3 to V _{SS} +12		
CONT pin voltage	V _{CONT}	V _{SS} -0.3 to V _{SS} +12		
CONT pin voltage	I _{CONT}	300		mA
Power dissipation	P _D	SOT-23-3	150	mW
		SOT-23-5	250	
		SOT-89-3	500	
Operating ambient temperature	T _{opr}	-40 to +85		°C
Storage ambient temperature	T _{stg}	-40 to +125		

Caution The absolute maximum ratings are rated values exceeding which the product could suffer physical damage. These values must therefore not be exceeded under any conditions.

■ **Electrical Characteristics**

1. **50 kHz Product (A type, D type)**

Table 10

(Ta=25°C unless otherwise specified)

Item	Symbol	Condition	Min.	Typ.	Max.	Unit	Test circuit	
Output voltage	V_{OUT}	—	$V_{OUT(S)} \times 0.976$	$V_{OUT(S)}$	$V_{OUT(S)} \times 1.024$	V	2	
Input voltage	V_{IN}	—	—	—	10			
Operation start voltage	V_{ST1}	$I_{OUT}=1\text{ mA}$	—	—	0.9			
Oscillation start voltage	V_{ST2}	No external parts, Voltage applied to V_{OUT}	—	—	0.8		1	
Operation holding voltage	V_{HLD}	$I_{OUT}=1\text{ mA}$, Measured by decreasing V_{IN} voltage gradually	0.7	—	—		2	
Current consumption 1	I_{SS1}	$V_{OUT}=V_{OUT(S)} \times 0.95$	S-835xx15 to 19	—	10.8	18.0	μA	1
			S-835xx20 to 29	—	13.3	22.2		
			S-835xx30 to 39	—	18.7	31.1		
			S-835xx40 to 49	—	24.7	41.1		
			S-835xx50 to 59	—	31.0	51.6		
			S-835xx60 to 65	—	37.8	63.0		
Current consumption 2	I_{SS2}	$V_{OUT}=V_{OUT(S)} + 0.5$	S-835xx15 to 19	—	4.8	9.5		
			S-835xx20 to 29	—	5.0	9.9		
			S-835xx30 to 39	—	5.1	10.2		
			S-835xx40 to 49	—	5.3	10.6		
			S-835xx50 to 59	—	5.5	10.9		
			S-835xx60 to 65	—	5.7	11.3		
Current consumption during shutdown (S-835xAxxMC Series)	I_{SSS}	$V_{ON}/\overline{\text{OFF}}=0\text{ V}$	—	—	0.5			
Switching current	I_{SW}	$V_{CONT}=0.4\text{ V}$	S-835xx15 to 19	80	128	—	mA	
			S-835xx20 to 24	103	165	—		
			S-835xx25 to 29	125	200	—		
			S-835xx30 to 39	144	231	—		
			S-835xx40 to 49	176	282	—		
			S-835xx50 to 59	200	320	—		
			S-835xx60 to 65	215	344	—		
Switching transistor leak current	I_{SWQ}	$V_{CONT}=V_{OUT}=10\text{ V}$	—	—	0.5	μA		
Line regulation	ΔV_{OUT1}	$V_{IN}=V_{OUT(S)} \times 0.4$ to $\times 0.6$	—	30	60	mV	2	
Load regulation	ΔV_{OUT2}	$I_{OUT}=10\text{ }\mu\text{A}$ to $V_{OUT(S)} / 250 \times 1.25$	—	30	60			
Output voltage temperature coefficient	$\frac{\Delta V_{OUT}}{\Delta T_a \bullet V_{OUT}}$	$T_a=-40^\circ\text{C} \sim +85^\circ\text{C}$	—	± 50	—	$\text{ppm}/^\circ\text{C}$		
Oscillation frequency	f_{OSC}	$V_{OUT}=V_{OUT(S)} \times 0.95$	42.5	50	57.5	kHz	1	
Maximum Duty ratio	MaxDuty	$V_{OUT}=V_{OUT(S)} \times 0.95$	75	83	90	%		
PWM/PFM switching duty ratio (S-8354 Series)	PFMDuty	$V_{IN}=V_{OUT(S)}-0.1\text{ V}$, No load	10	15	24			
ON / OFF pin input voltage (S-835xAxxMC Series)	V_{SH}	Measured oscillation at CONT pin	0.75	—	—	V		
	V_{SL1}	Judged the stop oscillation at CONT pin	—	—	0.3			
	V_{SL2}	When $V_{OUT} < 1.5\text{ V}$	—	—	0.2			
ON / OFF pin input current (S-835xAxxMC Series)	I_{SH}	$\text{ON} / \overline{\text{OFF}} \text{ pin}=V_{OUT(S)} \times 0.95$	-0.1	—	0.1	μA		
	I_{SL}	$\text{ON} / \overline{\text{OFF}} \text{ pin}=0\text{ V}$	-0.1	—	0.1			
Soft start time	t_{SS}	—	3.0	6.0	12.0	ms	2	
Efficiency	EFFI	—	—	85	—	%		

External parts

Coil: CDRH6D28-101 of Sumida Corporation

Diode: MA2Z748 (Schottky type) of Matsushita Electric Industrial Co., Ltd.

Capacitor: F93 (16 V, 22 μ F tantalum type) of Nichicon Corporation

$V_{IN}=V_{OUT(S)}\times 0.6$ applied, $I_{OUT}=V_{OUT(S)} / 250\Omega$

Shutdown function built-in type (S-835xAxxMC Series): ON/ $\overline{\text{OFF}}$ pin is connected to V_{OUT}

V_{DD}/V_{OUT} separate type (S-835xDxxMC Series): VDD pin is connected to V_{OUT} pin

- Remarks**
1. $V_{OUT(S)}$ specified above is the set output voltage value, and V_{OUT} is the typical value of the actual output voltage.
 2. V_{DD}/V_{OUT} separate type:
Step-up operation is performed from $V_{DD}=0.8$ V. However, $1.8\text{ V}\leq V_{DD}<10$ V is recommended to stabilize the output voltage and oscillation frequency. ($V_{DD}\geq 1.8$ V must be applied for products with a set value of less than 1.9 V.)

2. 30 kHz Product (C type)

Table 11

(Ta=25°C unless otherwise specified)

Item	Symbol	Condition	Min.	Typ.	Max.	Unit	Test circuit	
Output voltage	V_{OUT}	—	$V_{OUT(S)} \times 0.976$	$V_{OUT(S)}$	$V_{OUT(S)} \times 1.024$	V	2	
Input voltage	V_{IN}	—	—	—	10			
Operation start voltage	V_{ST1}	$I_{OUT}=1\text{ mA}$	—	—	0.9			
Oscillation start voltage	V_{ST2}	No external parts, Voltage applied to V_{OUT}	—	—	0.8		1	
Operation holding voltage	V_{HLD}	$I_{OUT}=1\text{ mA}$, Measured by decreasing V_{IN} voltage gradually	0.7	—	—		2	
Current consumption 1	I_{SS1}	$V_{OUT}=V_{OUT(S)} \times 0.95$	S-835xx20 to 29	—	9.8	16.4	μA	1
			S-835xx30 to 39	—	13.1	21.9		
			S-835xx40 to 49	—	16.8	28.0		
			S-835xx50 to 59	—	20.7	34.5		
			S-835xx60 to 65	—	24.8	41.4		
Current consumption 2	I_{SS2}	$V_{OUT}=V_{OUT(S)} + 0.5$	S-835xx20 to 29	—	435	9.0		
			S-835xx30 to 39	—	4.7	9.4		
			S-835xx40 to 49	—	4.9	9.7		
			S-835xx50 to 59	—	5.1	10.1		
			S-835xx60 to 65	—	5.2	10.4		
Switching current	I_{SW}	$V_{CONT}=0.4\text{ V}$	S-835xx20 to 24	52	83	—	mA	
			S-835xx25 to 29	62	100	—		
			S-835xx30 to 39	72	115	—		
			S-835xx40 to 49	88	141	—		
			S-835xx50 to 59	100	160	—		
S-835xx60 to 65	108	172	—					
Switching transistor leak current	I_{SWQ}	$V_{CONT}=V_{OUT}=10\text{ V}$	—	—	0.5	μA		
Line regulation	ΔV_{OUT1}	$V_{IN}=V_{OUT(S)} \times 0.4$ to $\times 0.6$	—	30	60	mV	2	
Load regulation	ΔV_{OUT2}	$I_{OUT}=10\text{ }\mu\text{A}$ to $V_{OUT(S)} / 250 \times 1.25$	—	30	60			
Output voltage temperature coefficient	$\frac{\Delta V_{OUT}}{\Delta T_a \bullet V_{OUT}}$	Ta=−40°C to +85°C	—	±50	—	$\text{ppm}/^\circ\text{C}$		
Oscillation frequency	f_{OSC}	$V_{OUT}=V_{OUT(S)} \times 0.95$	25	30	35	kHz	1	
Maximum duty ratio	MaxDuty	$V_{OUT}=V_{OUT(S)} \times 0.95$	75	83	90	%		
PWM/PFM switching duty ratio (S-8354 Series)	PFMDuty	$V_{IN}=V_{OUT(S)} - 0.1\text{ V}$, No load	10	15	24			
Soft start time	t_{SS}	—	3.0	6.0	12.0	ms	2	
Efficiency	EFFI	—	—	84	—	%		

External parts

- Coil: CDRH6D28-101 of Sumida Corporation
- Diode: MA2Z748 (Schottky type) of Matsushita Electric Industrial Co., Ltd.
- Capacitor: F93 (16 V, 22 μF tantalum type) of Nichicon Corporation

$V_{IN}=V_{OUT(S)} \times 0.6$ applied, $I_{OUT}=V_{OUT(S)} / 250\Omega$

Remarks 1. $V_{OUT(S)}$ specified above is the set output voltage value, and V_{OUT} is the typical value of the actual output voltage.

3. 250 kHz Product (H type, J type)

Table 12

(Ta=25°C unless otherwise specified)

Item	Symbol	Condition	Min.	Typ.	Max.	Unit	Test circuit	
Output voltage	V_{OUT}	—	$V_{OUT(S)} \times 0.976$	$V_{OUT(S)}$	$V_{OUT(S)} \times 1.024$	V	2	
Input voltage	V_{IN}	—	—	—	10			
Operation start voltage	V_{ST1}	$I_{OUT}=1\text{ mA}$	—	—	0.9			
Oscillation start voltage	V_{ST2}	No external parts, Voltage applied to V_{OUT}	—	—	0.8		1	
Operation holding voltage	V_{HLD}	$I_{OUT}=1\text{ mA}$, Measured by decreasing V_{IN} gradually	0.7	—	—		2	
Current consumption 1	I_{SS1}	$V_{OUT}=V_{OUT(S)} \times 0.95$	S-835xx15 to 19	—	36.5	60.8	μA	1
			S-835xx20 to 29	—	48.3	80.5		
			S-835xx30 to 39	—	74.3	123.8		
			S-835xx40 to 49	—	103.1	171.9		
			S-835xx50 to 59	—	134.1	223.5		
			S-835xx60 to 65	—	167.0	278.4		
Current consumption 2	I_{SS2}	$V_{OUT}=V_{OUT(S)} + 0.5$	S-835xx15 to 19	—	9.1	18.2		
			S-835xx20 to 29	—	9.3	18.6		
			S-835xx30 to 39	—	9.5	18.9		
			S-835xx40 to 49	—	9.7	19.3		
			S-835xx50 to 59	—	9.8	19.6		
			S-835xx60 to 65	—	10.0	19.9		
Current consumption during shutdown (S-835xHxxMC Series)	I_{SSS}	$V_{ON} / \overline{\text{OFF}} = 0\text{ V}$	—	—	0.5			
Switching current	I_{SW}	$V_{CONT}=0.4\text{ V}$	S-835xx15 to 19	80	128	—	mA	
			S-835xx20 to 24	103	165	—		
			S-835xx25 to 29	125	200	—		
			S-835xx30 to 39	144	231	—		
			S-835xx40 to 49	176	282	—		
			S-835xx50 to 59	200	320	—		
Switching transistor leak current	I_{SWQ}	$V_{CONT}=V_{OUT}=10\text{ V}$	S-835xx15 to 19	—	—	0.5	μA	
			S-835xx20 to 24	—	—	0.5		
			S-835xx25 to 29	—	—	0.5		
			S-835xx30 to 39	—	—	0.5		
			S-835xx40 to 49	—	—	0.5		
			S-835xx50 to 59	—	—	0.5		
Line regulation	ΔV_{OUT1}	$V_{IN}=V_{OUT(S)} \times 0.4$ to $\times 0.6$	—	30	60	mV	2	
Load regulation	ΔV_{OUT2}	$I_{OUT}=10\text{ }\mu\text{A}$ to $V_{OUT(S)} / 250 \times 1.25$	—	30	60			
Output voltage temperature coefficient	$\frac{\Delta V_{OUT}}{\Delta T_a \bullet V_{OUT}}$	$T_a = -40^\circ\text{C}$ to $+85^\circ\text{C}$	—	± 50	—	$\text{ppm}/^\circ\text{C}$		
Oscillation frequency	f_{OSC}	$V_{OUT}=V_{OUT(S)} \times 0.95$	212.5	250	287.5	kHz	1	
Maximum duty ratio	MaxDuty	$V_{OUT}=V_{OUT(S)} \times 0.95$	70	78	85	%		
PWM/PFM switching duty ratio (S-8354 Series)	PFMDuty	$V_{IN}=V_{OUT(S)} - 0.1\text{ V}$, No load	10	15	24			
ON / $\overline{\text{OFF}}$ pin input voltage (S-835xHxxMC Series)	V_{SH}	Measured the oscillation at CONT pin	0.75	—	—	V		
	V_{SL1}	Judged the stop of oscillation at CONT pin	—	—	0.3			
	V_{SL2}	When $V_{OUT} < 1.5\text{ V}$	—	—	0.2			
ON / $\overline{\text{OFF}}$ pin input current (S-835xHxxMC Series)	I_{SH}	ON / $\overline{\text{OFF}}$ pin = $V_{OUT(S)} \times 0.95$	-0.1	—	0.1	μA		
	I_{SL}	ON / $\overline{\text{OFF}}$ pin = 0 V	-0.1	—	0.1			
Soft start	t_{SS}	—	1.8	3.6	7.2	ms	2	
Efficiency	EFFI	—	—	85	—	%		

External parts

Coil: CDRH6D28-220 of Sumida Corporation

Diode: MA2Z748 (Schottky type) of Matsushita Electric Industrial Co., Ltd.

Capacitor: F93 (16 V, 22 μ F tantalum type) of Nichicon Corporation

$V_{IN}=V_{OUT(S)}\times 0.6$ applied, $I_{OUT}=V_{OUT(S)} / 250\Omega$

Shutdown function built-in type (S-835xHxxMC Series): ON/ $\overline{\text{OFF}}$ pin is connected to V_{OUT}

V_{DD}/V_{OUT} separate type (S-835xJxxMC Series): V_{DD} pin is connected to V_{OUT} pin

- Remarks**
1. $V_{OUT(S)}$ specified above is the set output voltage value, and V_{OUT} is the typical value of the actual output voltage.
 2. V_{DD}/V_{OUT} separate type:
Step-up operation is performed from $V_{DD}=0.8$ V. However, $1.8\text{ V}\leq V_{DD}<10$ V is recommended to stabilize the output voltage and oscillation frequency. ($V_{DD}\geq 1.8$ V must be applied for products with a set value of less than 1.9 V.)

■ Test Circuits

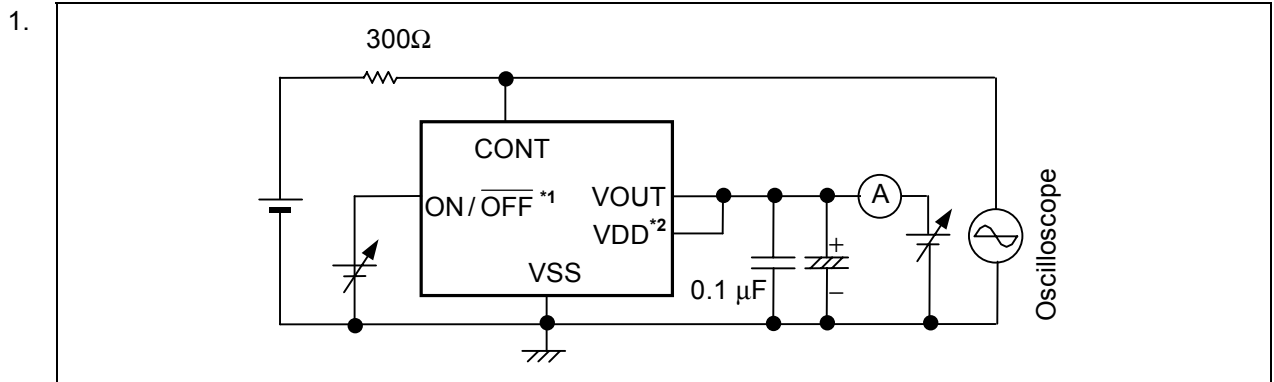

Figure 7

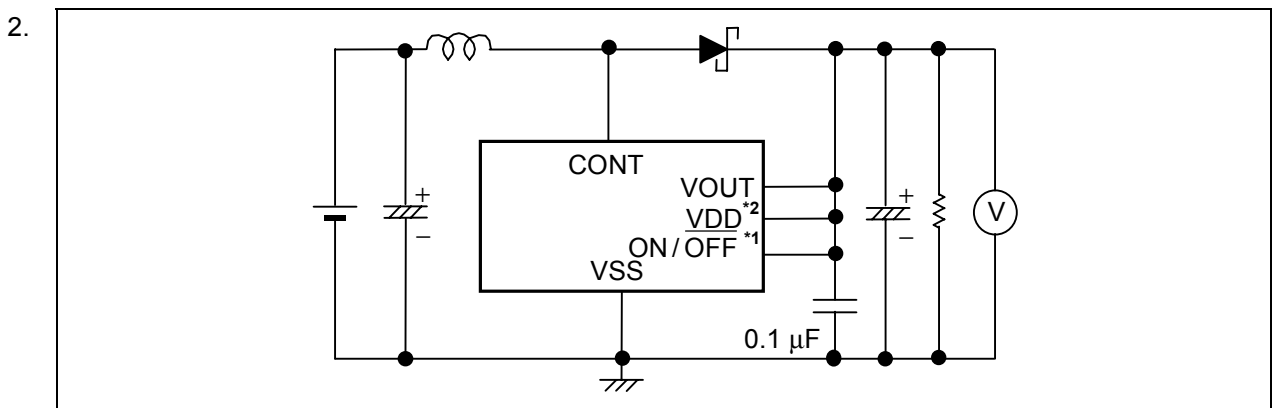

Figure 8

*1. Only for S-835xAxxMC Series and S-835xHxxMC Series

*2. Only for S-835xDxxMC Series and S-835xJxxMC Series

■ Operation

1. Step-up DC-DC Converter

The S-8353 Series is a DC-DC converter that uses a pulse width modulation method (PWM) and features low current consumption.

In the S-8353 Series, the switching frequency does not change, although the pulse width changes from 0 % to 83 % (78 % for H type and J type) corresponding to each load current. The ripple voltage generated from switching can thus be removed easily using a filter because the switching frequency is constant. The S-8354 Series is a DC-DC converter that automatically switches between a pulse width modulation method (PWM) and a pulse frequency modulation method (PFM), depending on the load current, and features low current consumption.

The S-8354 Series operates under PWM control with the pulse width duty changing from 15 % to 83 % (78 % for H type and J type) when the output load current is high. On the other hand, when the output current is low, the S-8354 Series operates under PFM control with the pulse width duty fixed at 15 %, and pulses are skipped according to the load current. The oscillator thus oscillates intermittently so that the resultant lower current consumption prevents a reduction in the efficiency when the load current is low. The switching point from PWM control to PFM control depends on the external devices (coil, diode, etc.), input voltage, and output voltage. This series is an especially efficient DC-DC converter at an output current of around 100 μ A.

For this IC, a built-in soft start circuit controls the rush current and overshoot of the output voltage when the power is turned on or the ON/OFF pin is set to "H" level.

2. ON/OFF Pin (Shutdown Pin) (Only for S-835xAxxMC Series and S-835xHxxMC Series)

Stops or starts step-up operation.

Setting the ON/OFF pin to "L" level stops operation of all the internal circuits and reduces the current consumption significantly.

DO NOT use the ON/OFF pin in a floating state because it has the structure shown in **Figure 9** and is not pulled up or pulled down internally. DO NOT apply a voltage of between 0.3 V and 0.75 V to the ON/OFF pin because applying such a voltage increases the current consumption. If the ON/OFF pin is not used, connect it to the VOUT pin.

The ON/OFF pin does not have hysteresis.

Table 13

ON/OFF pin	CR oscillation circuit	Output voltage
"H"	Operation	Fixed
"L"	Stop	$\cong V_{IN}^{*1}$

*1. Voltage obtained by extracting the voltage drop due to the DC resistance of the inductor and the diode forward voltage from V_{IN} .

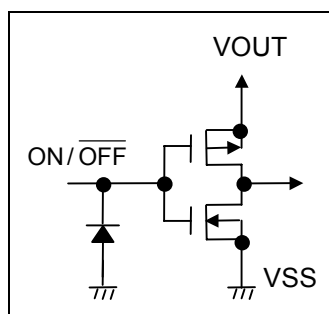
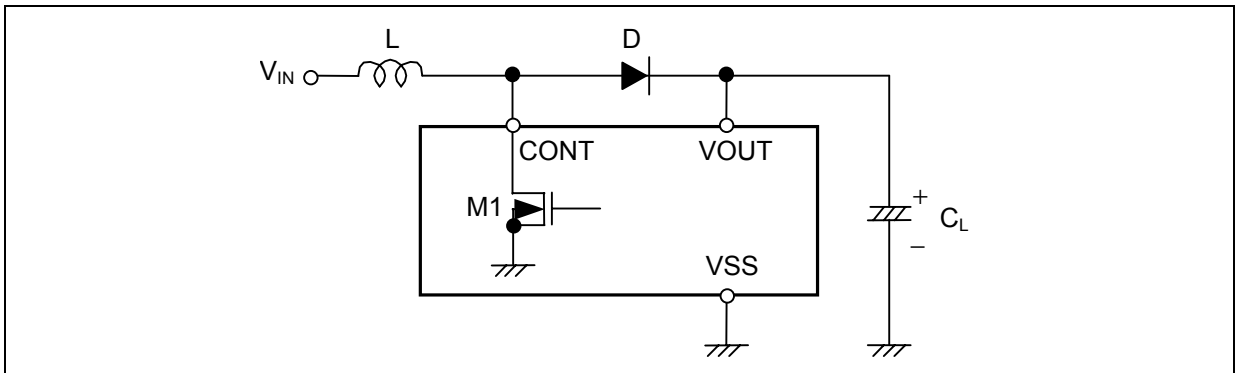

Figure 9 ON/OFF Pin Structure

3. Step-up Switching Regulator Circuit for Basic Equations



Caution The above connection diagram will not guarantee successful operation. Perform through evaluation using the actual application to set the constant.

Figure 10 Step-up switching regulator circuit for basic equations

The following are the basic equations {(1) through (7)} of the step-up switching regulator. (Refer to **Figure 10**)

Voltage at CONT pin at the moment M1 is turned ON, V_A^{*1} :

$$V_A = V_S^{*2} \dots\dots\dots (1)$$

- *1. Current (I_L) flowing through L is zero
- *2. Non-saturated voltage of M1

The change in I_L over time:

$$\frac{dI_L}{dt} = \frac{V_L}{L} = \frac{V_{IN} - V_S}{L} \dots\dots\dots (2)$$

Integration of equation (2) (I_L):

$$I_L = \left(\frac{V_{IN} - V_S}{L} \right) \cdot t \dots\dots\dots (3)$$

I_L flows while M1 is ON (t_{ON}). The time of t_{ON} is determined by the oscillation frequency of OSC.

The peak current (I_{PK}) after t_{ON} :

$$I_{PK} = \left(\frac{V_{IN} - V_S}{L} \right) \cdot t_{ON} \dots\dots\dots (4)$$

The energy stored in L is represented by $1/2 \cdot L \cdot (I_{PK})^2$.

When M1 is turned OFF (t_{OFF}), the energy stored in L is emitted through a diode to the output capacitor.

Then, the reverse voltage (V_L) is generated:

$$V_L = (V_{OUT} + V_D^{*1}) - V_{IN} \dots\dots\dots (5)$$

- *1. Diode forward voltage

The voltage at CONT pin rises only by $V_{OUT} + V_D$.

The change in the current (I_L) flowing through the diode into V_{OUT} during t_{OFF} :

$$\frac{dI_L}{dt} = \frac{V_L}{L} = \frac{V_{OUT} + V_D - V_{IN}}{L} \dots\dots\dots (6)$$

Integration of equation (6) is as follows:

$$I_L = I_{PK} - \left(\frac{V_{OUT} + V_D - V_{IN}}{L} \right) \cdot t \dots\dots\dots (7)$$

During t_{ON} , the energy is stored in L and is not transmitted to V_{OUT} . When receiving the output current (I_{OUT}) from V_{OUT} , the energy of the capacitor (C_L) is consumed. As a result, the pin voltage of C_L is reduced, and goes to the lowest level after M1 is turned ON (t_{ON}). When M1 is turned OFF, the energy stored in L is transmitted through the diode to C_L , and the voltage of C_L rises rapidly. V_{OUT} is a time function, and therefore indicates the maximum value (ripple voltage: V_{P-P}) when the current flowing through into V_{OUT} and load current (I_{OUT}) match.

Next, the ripple voltage is determined as follows:

I_{OUT} vs. t_1 (time) from when M1 is turned OFF (after t_{ON}) to when V_{OUT} reaches the maximum level:

$$I_{OUT} = I_{PK} - \left(\frac{V_{OUT} + V_D - V_{IN}}{L} \right) \cdot t_1 \dots\dots\dots (8)$$

$$\therefore t_1 = (I_{PK} - I_{OUT}) \cdot \left(\frac{L}{V_{OUT} + V_D - V_{IN}} \right) \dots\dots\dots (9)$$

When M1 is turned OFF (t_{OFF}), $I_L=0$ (when the energy of the inductor is completely transmitted):

Based on equation (7),

$$\left(\frac{L}{V_{OUT} + V_D - V_{IN}} \right) = \frac{t_{OFF}}{I_{PK}} \dots\dots\dots (10)$$

When substituting equation (10) for equation (9),

$$t_1 = t_{OFF} - \left(\frac{I_{OUT}}{I_{PK}} \right) \cdot t_{OFF} \dots\dots\dots (11)$$

Electric charge ΔQ_1 which is charged in C_L during t_1 :

$$\Delta Q_1 = \int_0^{t_1} I_L dt = I_{PK} \cdot \int_0^{t_1} dt - \frac{V_{OUT} + V_D - V_{IN}}{L} \cdot \int_0^{t_1} t dt = I_{PK} \cdot t_1 - \frac{V_{OUT} + V_D - V_{IN}}{L} \cdot \frac{1}{2} t_1^2 \dots\dots\dots (12)$$

When substituting equation (12) for equation (9):

$$\Delta Q_1 = I_{PK} - \frac{1}{2} (I_{PK} - I_{OUT}) \cdot t_1 = \frac{I_{PK} + I_{OUT}}{2} \cdot t_1 \dots\dots\dots (13)$$

A rise in voltage (V_{P-P}) due to ΔQ_1 :

$$V_{P-P} = \frac{\Delta Q_1}{C_L} = \frac{1}{C_L} \cdot \left(\frac{I_{PK} + I_{OUT}}{2} \right) \cdot t_1 \dots\dots\dots (14)$$

When taking into consideration I_{OUT} to be consumed during t_1 and the ESR (Equivalent Series Resistance) of C_L , namely R_{ESR} :

$$V_{P-P} = \frac{\Delta Q_1}{C_L} = \frac{1}{C_L} \cdot \left(\frac{I_{PK} + I_{OUT}}{2} \right) \cdot t_1 + \left(\frac{I_{PK} + I_{OUT}}{2} \right) \cdot R_{ESR} - \frac{I_{OUT} \cdot t_1}{C_L} \dots\dots\dots (15)$$

When substituting equation (11) for equation (15):

$$V_{P-P} = \frac{(I_{PK} - I_{OUT})^2}{2I_{PK}} \cdot \frac{t_{OFF}}{C_L} + \left(\frac{I_{PK} + I_{OUT}}{2} \right) \cdot R_{ESR} \dots\dots\dots (16)$$

Therefore to reduce the ripple voltage, it is important that the capacitor connected to the output pin has a large capacity and a small ESR.

■ External Parts Selection for DC-DC Converter

The relationship between the major characteristics of the step-up circuit and the characteristic parameters of the external parts is shown in **Figure 11**.

For larger output current?	For higher efficiency?		For smaller ripple voltage?
	PFM control	PWM control	
Smaller inductance	Larger inductance		
Smaller DC resistance of inductor			
Larger output capacitance			Larger output capacitance

Figure 11 Relationship between Major Characteristics of Step-up Circuit and External Parts

1. Inductor

The inductance has a strong influence on the maximum output current (I_{OUT}) and efficiency (η). The peak current (I_{PK}) increases by decreasing L and the stability of the circuit improves and I_{OUT} increases. If L is made even smaller, the efficiency falls causing a decline in the current drive capacity for the switching transistor, and I_{OUT} decreases. The loss of I_{PK} by the switching transistor decreases by increasing L and the efficiency becomes maximum at a certain L value. Increasing L further decreases the efficiency due to the loss of coil DC resistance. I_{OUT} also decreases. A higher oscillation frequency allows selection of a lower L value, making the coil smaller. The recommended inductances are 47 to 220 μ H for A, C, and D types, and 10 to 47 μ H for H and J types. Observe the allowable inductor current when choosing an inductor. Exceeding the allowable current of the inductor causes magnetic saturation, resulting in very low efficiency and destruction of the IC chip due to a large current.

Choose an inductor so that I_{PK} does not exceed the allowable current. I_{PK} in con-continuous mode is calculated from the following equation:

$$I_{PK} = \sqrt{\frac{2 I_{OUT} (V_{OUT} + V_D - V_{IN})}{f_{osc} \cdot L}} \quad (A) \dots\dots\dots (17)$$

f_{osc} =oscillation frequency, $V_D \cong 0.4$ V.

2. Diode

Use an external diode that meets the following requirements:

- Low forward voltage: ($V_F < 0.3$ V)
- High switching speed: (50 ns max.)
- Reverse voltage: $V_{OUT} + V_F$ or more
- Rated current: I_{PK} or more

3. Capacitor (C_{IN}, C_L)

A capacitor on the input side (C_{IN}) improves the efficiency by reducing the power impedance and stabilizing the input current. Select a C_{IN} value according to the impedance of the power supply used.

A capacitor on the output side (C_L) is used for smoothing the output voltage. For step-up types, the output voltage flows intermittently to the load current, so step-up types need a larger capacitance than step-down types. Therefore, select an appropriate capacitor in accordance with the ripple voltage, which increases in the case of a high output voltage or a high load current. The capacitor value should be at least 10 μF. Select capacitor with an appropriate ESR (Equivalent Series Resistance) for stable output voltage. The stable range of voltage for this IC depends on the ESR. Although the inductance (L) is also a factor, an ESR of 30 mΩ to 500 mΩ maximizes the characteristics. However, the best ESR value may depend on the value of L, the capacitance, the wiring, and the applications (output load). Therefore, fully evaluate the ESR under the actual operating conditions to determine the best value.

Figure 18 of Application Circuits shows an example of a circuit that uses a ceramic capacitor and the external resistance (ESR) for reference.

4. V_{DD}/V_{OUT} Separate Types (Only for D type and J type)

The D and J types are ideal for the following applications because the power pin for the IC chip and the V_{OUT} pin for the output voltage are separated.

- (1) When changing the output voltage with external resistance.
 - (2) When outputting a high voltage within the operating voltage (10 V).
- Choose the products in the **Table 14** according to the applications (1) or (2) above.

Table 14

Output voltage V _{CC}	1.8 V ≤ V _{CC} < 5 V	5 V ≤ V _{CC} ≤ 10 V
S-835xx18	Yes	—
S-835xx50	—	Yes
Connection to VDD pin	V _{IN} or V _{CC}	V _{IN}

Cautions

1. This IC starts a step-up operation at V_{DD}=0.8 V, but set 1.8 ≤ V_{DD} ≤ 10 V to stabilize the output voltage and frequency of the oscillator. (Input a voltage of 1.8 V or more at the VDD pin for all products with a setting less than 1.9 V.) An input voltage of 1.8 V or more at the VDD pin allows connection of the VDD pin to either the input power V_{IN} pin or output power V_{OUT} pin.

2. Choose external resistors R_A and R_B so as to not affect the output voltage, considering that there is impedance between the V_{OUT} pin and V_{SS} pin in the IC chip.

The internal resistance between the V_{OUT} pin and V_{SS} pin is as follows:

- (1) S-835xx18: 2.1 MΩ to 14.8 MΩ
- (2) S-835xx20: 1.4 MΩ to 14.8 MΩ
- (3) S-835xx30: 1.4 MΩ to 14.2 MΩ
- (4) S-835xx50: 1.4 MΩ to 12.1 MΩ

3. Attach a capacitor (C_C) in parallel to the R_A resistance when an unstable event such as oscillation of the output voltage occurs. Calculate C_C using the following equation:

$$C_C [F] = \frac{1}{2 \cdot \pi \cdot R_A \cdot 20 \text{ kHz}}$$

■ Standard Circuits

1. S-8353AxxMA/UA, S-8353CxxMA, S-8353HxxMA/UA, S-8354AxxMA/UA, S-8354CxxMA, S-8354HxxMA/UA

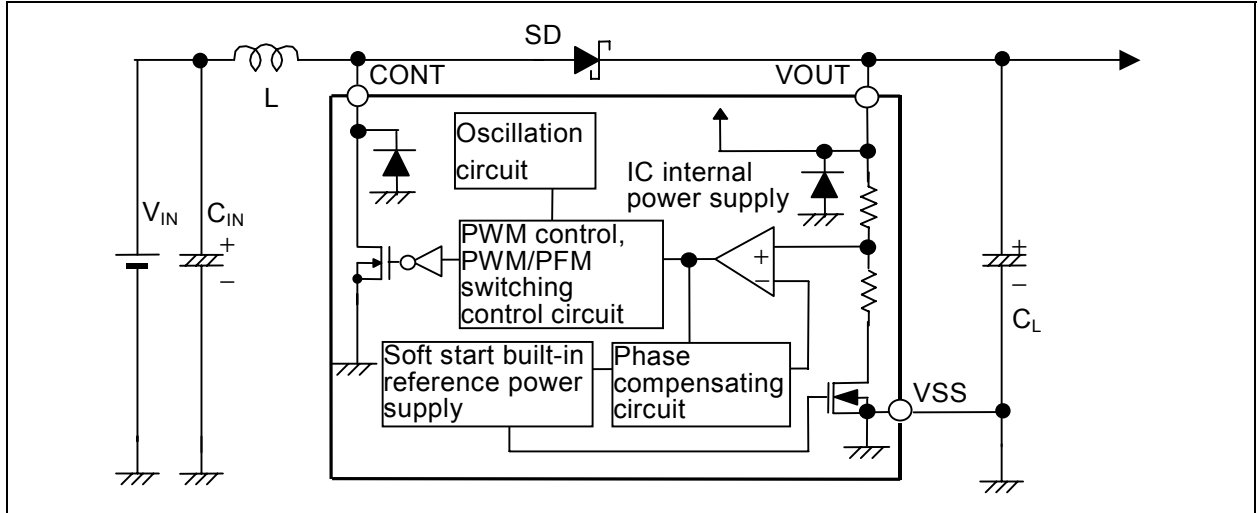

Remark The power supply for the IC chip is from the VOUT pin.

Figure 12

2. S-8353AxxMC, S-8353HxxMC, S-8354AxxMC, S-8354HxxMC

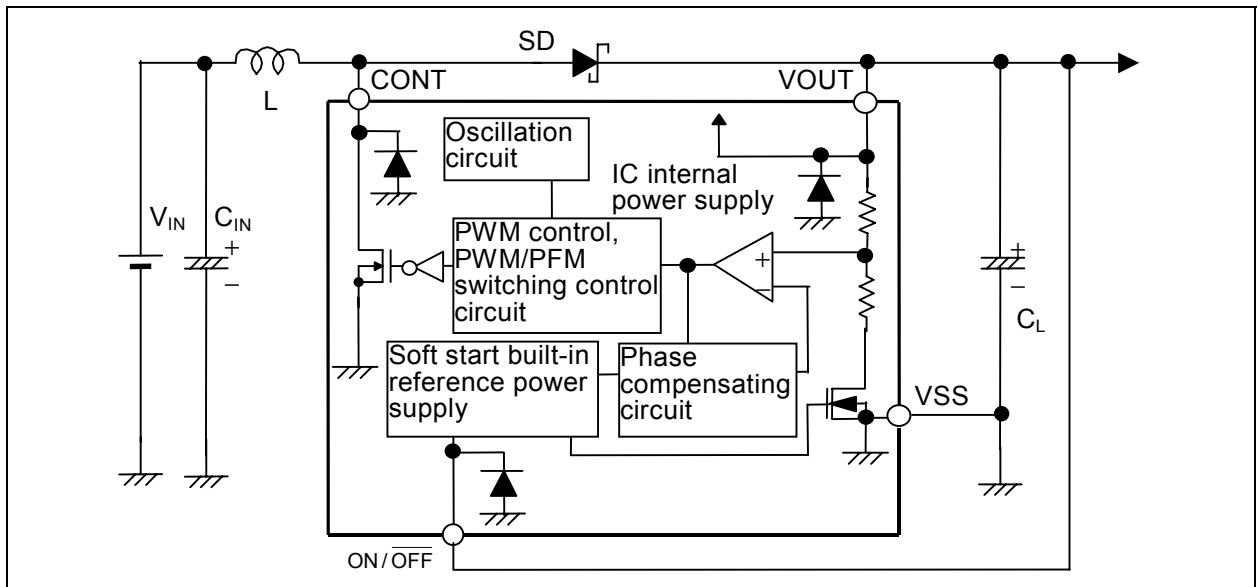

Remark The power supply for the IC chip is from the VOUT pin.

Figure 13

3. S-8353DxxMC, S-8353JxxMC, S-8354DxxMC, S-8354JxxMC

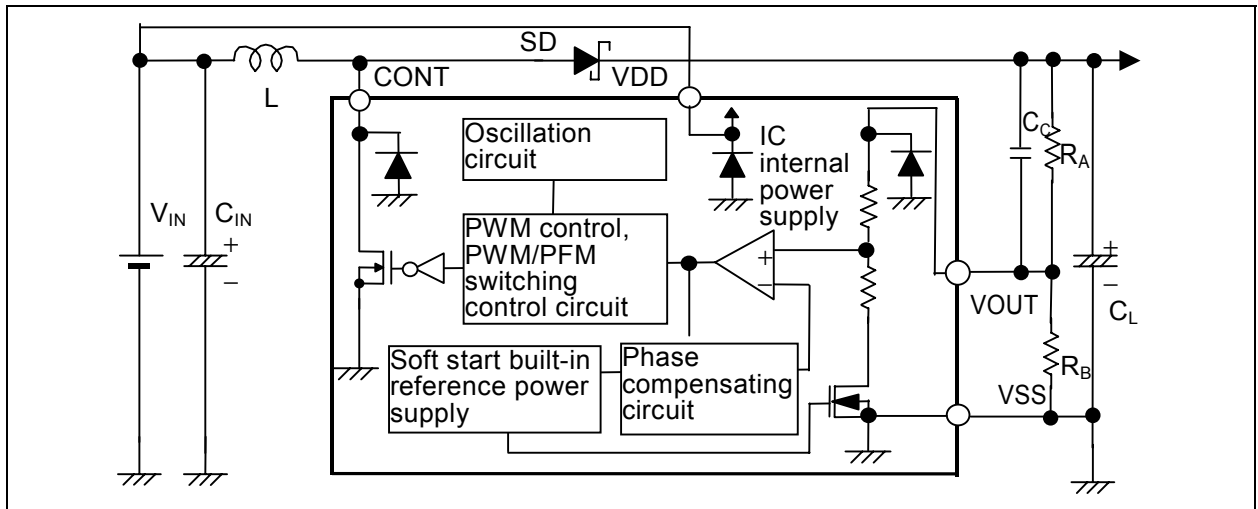

Remark The power supply for the IC chip is from the VOUT pin.

Figure 14

Caution The above connection diagram will not guarantee successful operation. Perform through evaluation using the actual application to set the constant.

■ Power Dissipation of Package

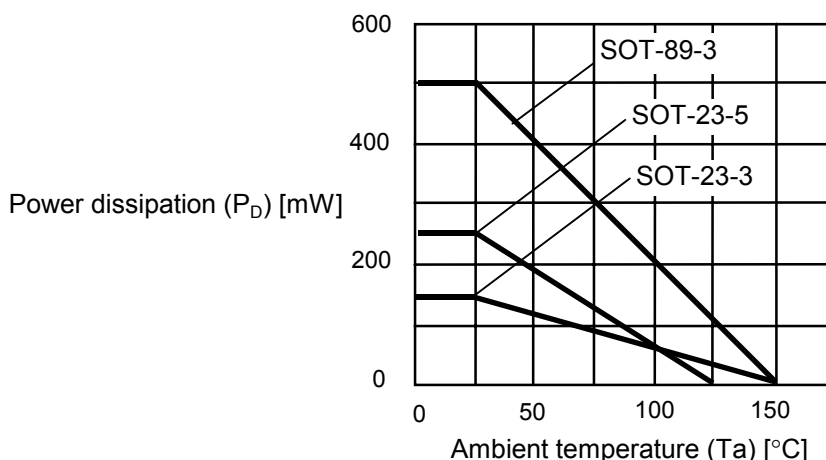

Figure 15 Power Dissipation of Package (Before Mounting)

■ Precautions

- Mount external capacitors, diodes, and coils as close as possible to the IC. Especially, mounting the output capacitor (capacitor between VDD pin and VSS pin for V_{DD}/V_{OUT} separate type) in the power supply line of the IC close to the IC can enable stable output characteristics. If it is impossible, it is recommended to mount and wire a ceramic capacitor of around 0.1 μF close to the IC.
- Characteristics ripple voltage and spike noise occur in IC containing switching regulators. Moreover rush current flows at the time of a power supply injection. Because these largely depend on the coil, the capacitor and impedance of power supply used, fully check them using an actually mounted model.
- The performance of this IC varies depending on the design of the PCB patterns, peripheral circuits and external parts. Thoroughly test all settings with your device. The recommended external part should be used wherever possible, but if this is not possible for some reason, contact an SII sales person.
- Do not apply an electrostatic discharge to this IC that exceeds the performance ratings of the built-in electrostatic protection circuit.
- SII claims no responsibility for any and all disputes arising out of or in connection with any infringement of the products including this IC upon patents owned a third party.

■ Application Circuits

Example of Ceramic Capacitor Application

When using a component with a small ESR, such as a ceramic capacitor, for the output capacitance, mount a resistor (R_1) equivalent to the ESR in series with the ceramic capacitor (C_L) as shown in **Figure 16**.

R_1 differs depending on the L value, capacitance, wiring, and application (output load).

The following example shows a circuit using $R_1=100\text{ m}\Omega$, output voltage=3.3 V, output load=100 mA and its characteristics.

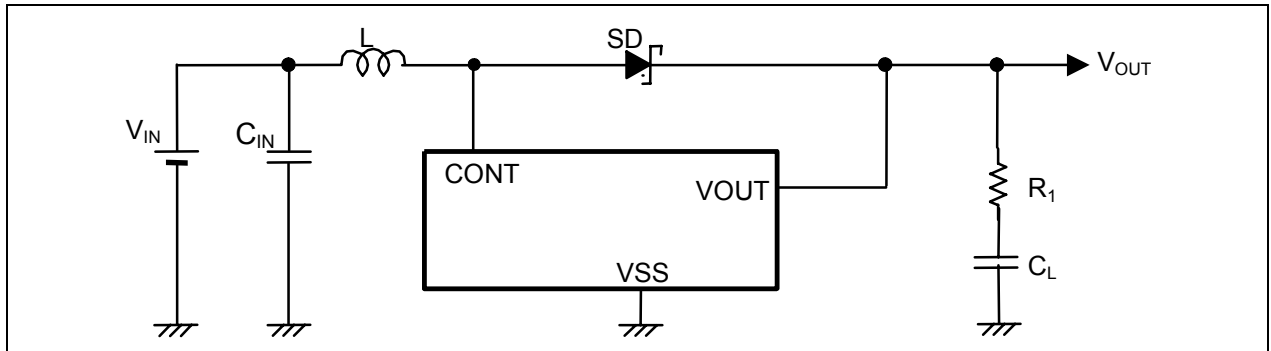

Caution The above connection diagram and constant will not guarantees successful operation. Perform through evaluation using the actual application to set the constant.

Figure 16 Circuit Using Ceramic Capacitor

Table 15

IC	L type name	SD type name	C_L (Ceramic capacitor)	R_1	Output Characteristics
S-8353A33	CDRH5D28-101	MA2Z748	10 $\mu\text{F}\times 2$	100 m Ω	(a), (b), (c)

Ceramic Capacitor Circuit Output Characteristics

1. Output current-Efficiency

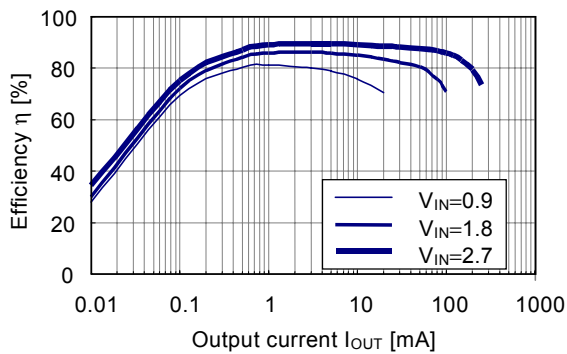

2. Output current-Output voltage

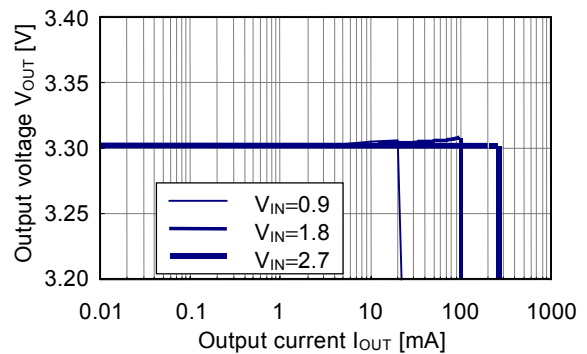

3. Output current-Ripple voltage

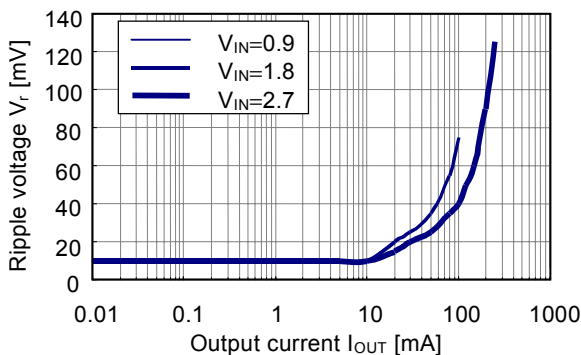

■ Examples of Major Temperature Characteristics ($T_a = -40$ to $+85^\circ\text{C}$)

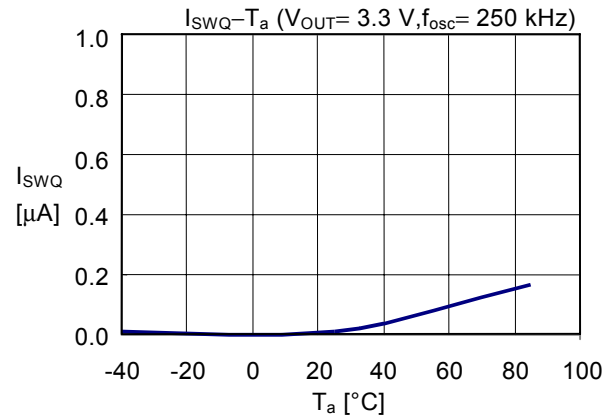
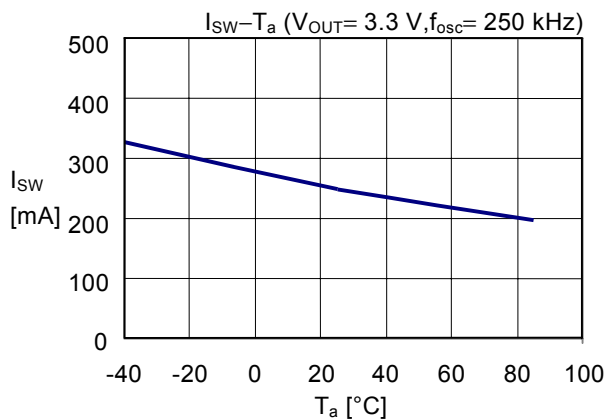
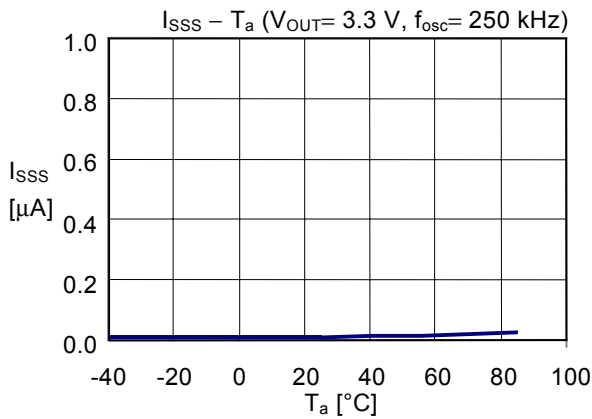
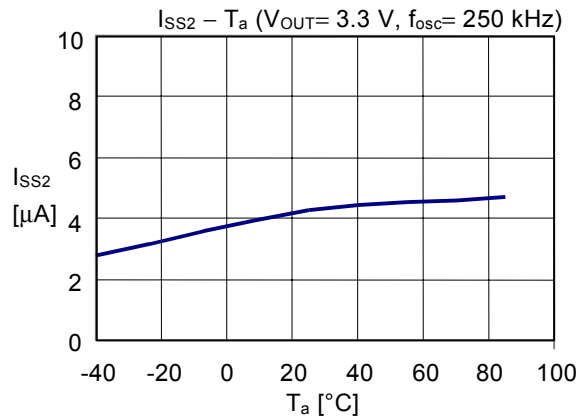
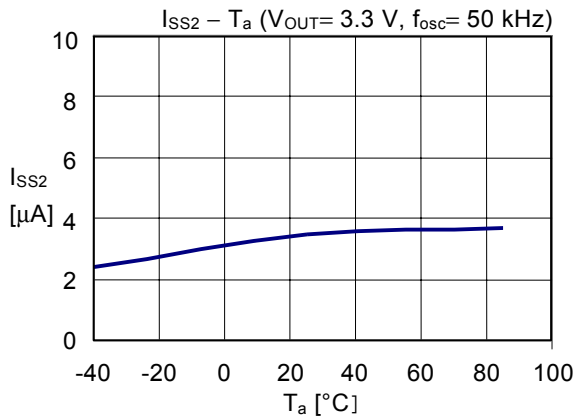
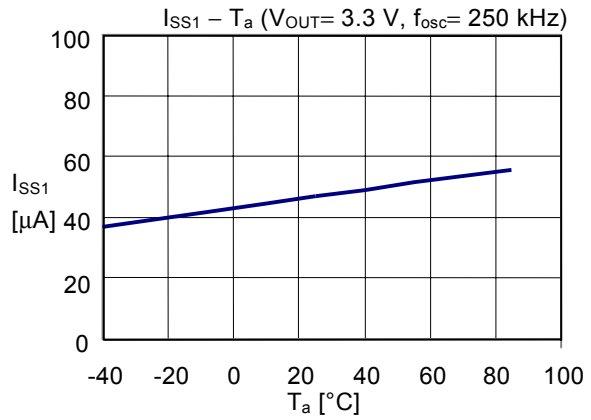
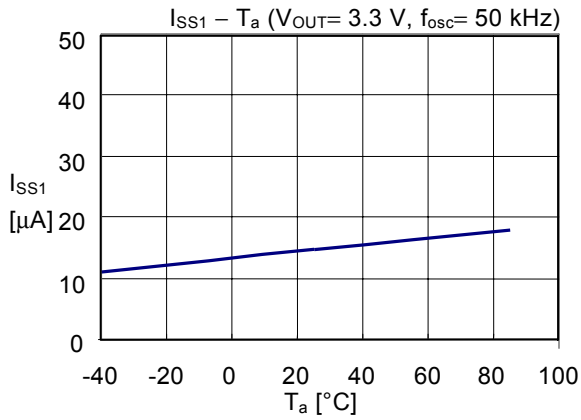

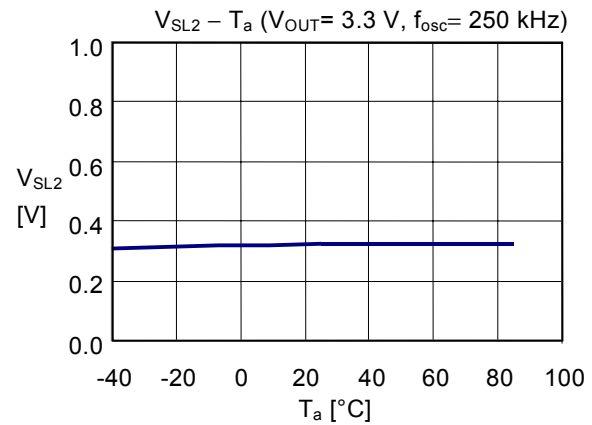
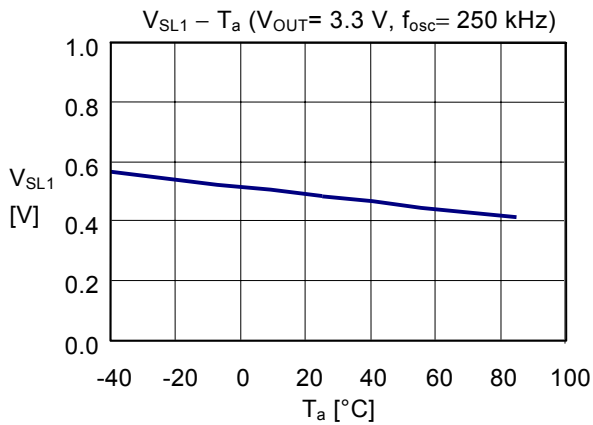
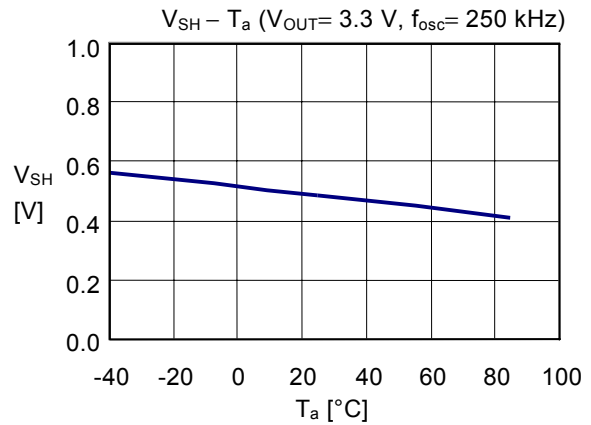
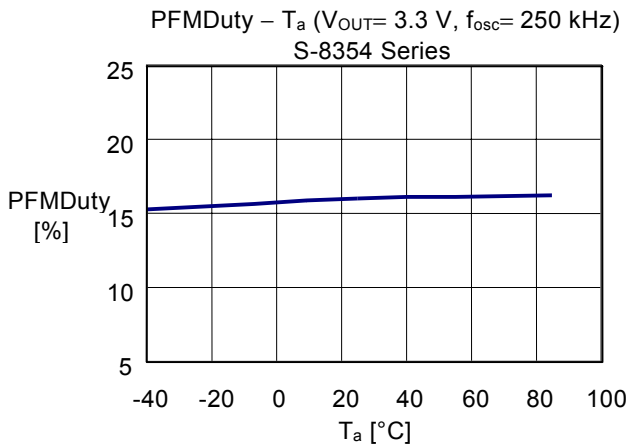
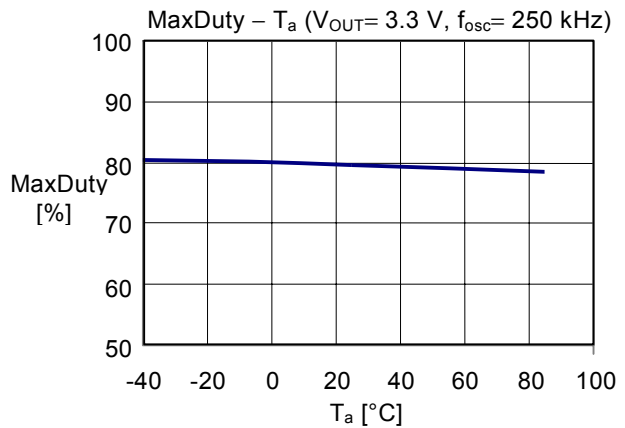
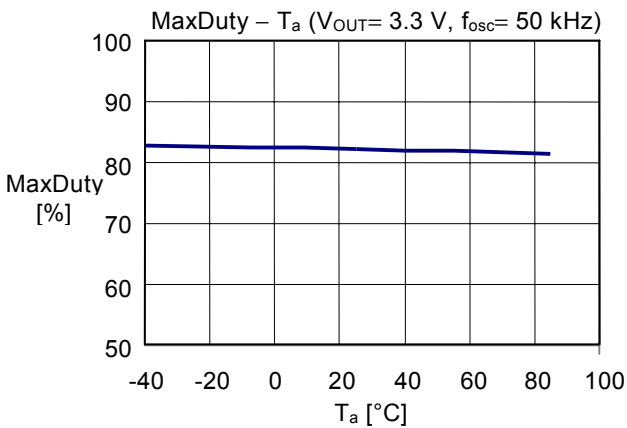
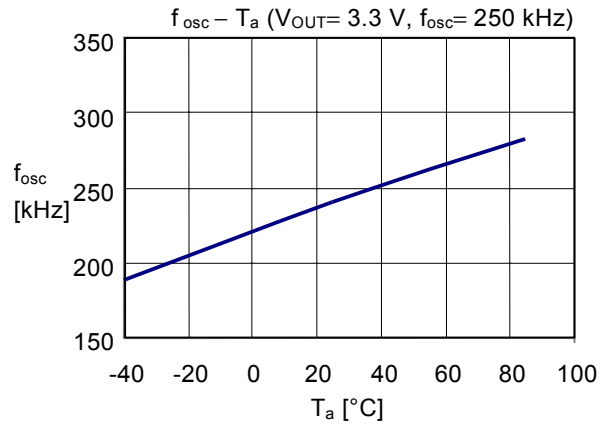
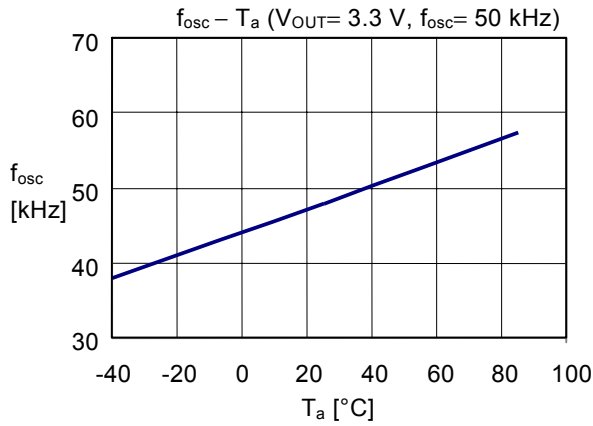

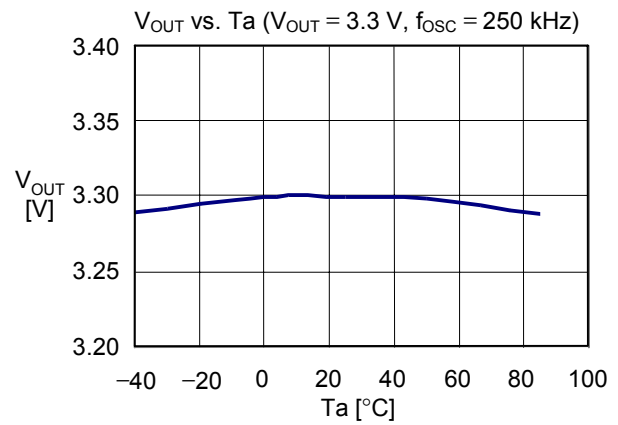
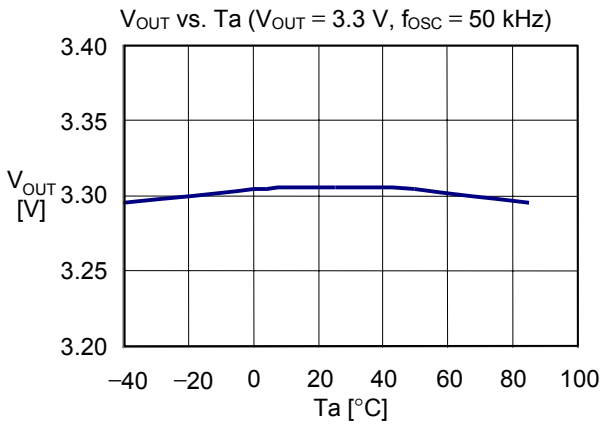
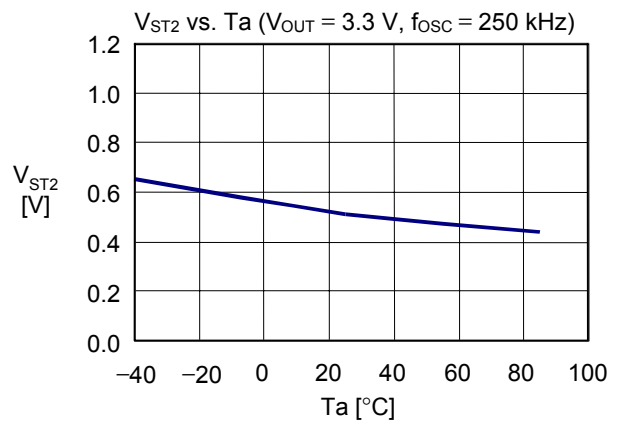
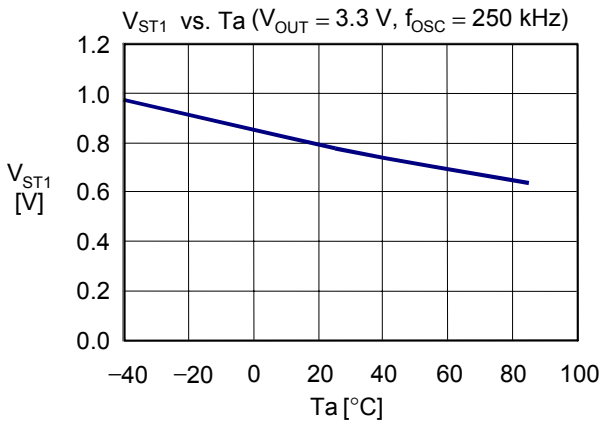
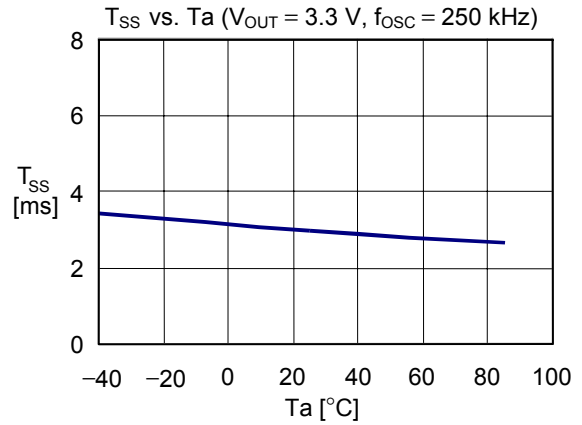
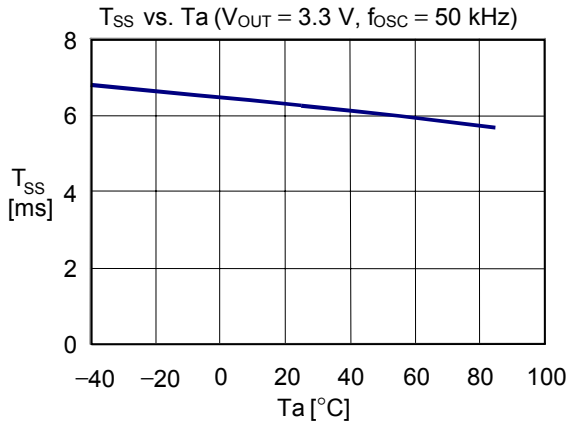

■ **Examples of Major Power Supply Dependence Characteristics (Ta=25°C)**

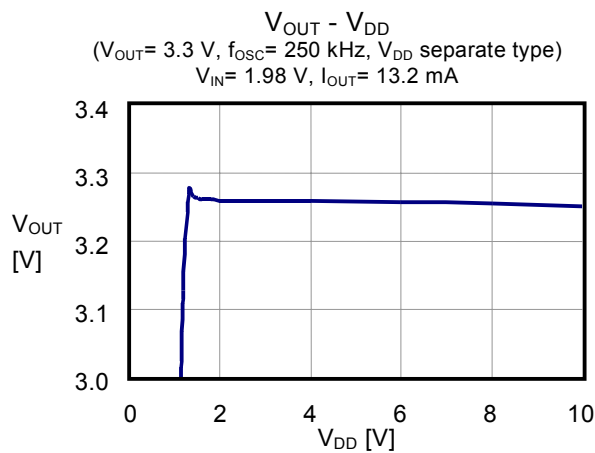
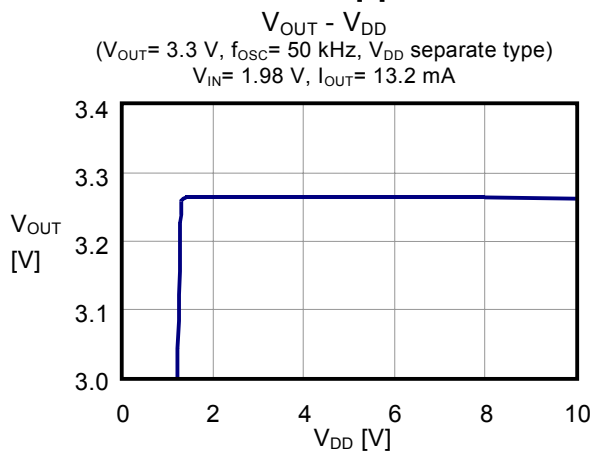
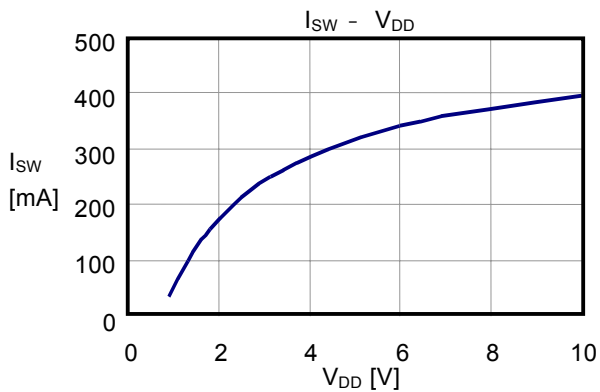
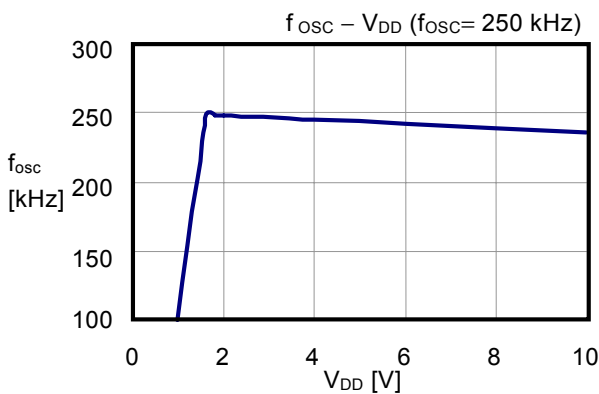
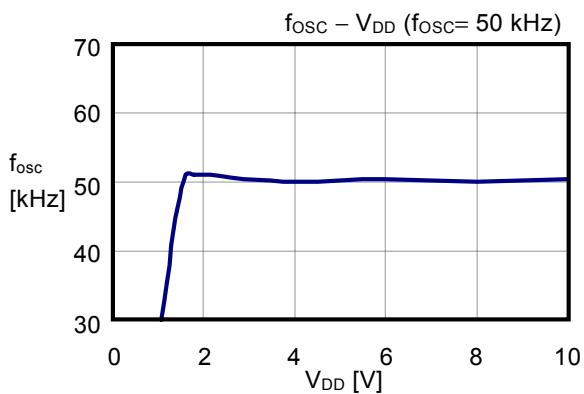
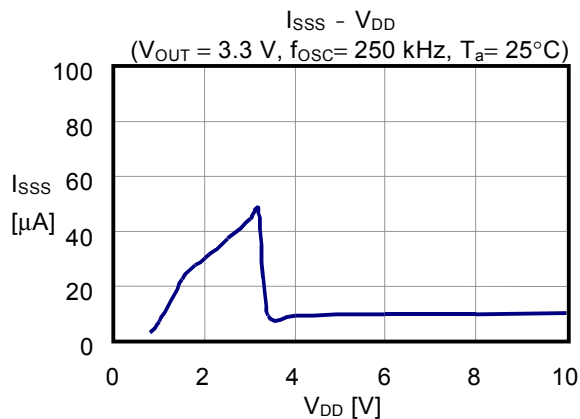
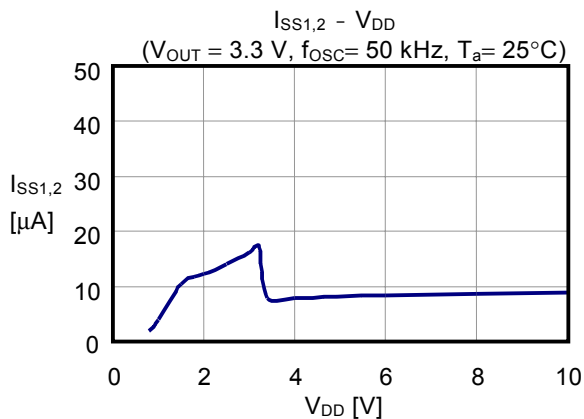

■ Output Waveforms

1. S-8353A33

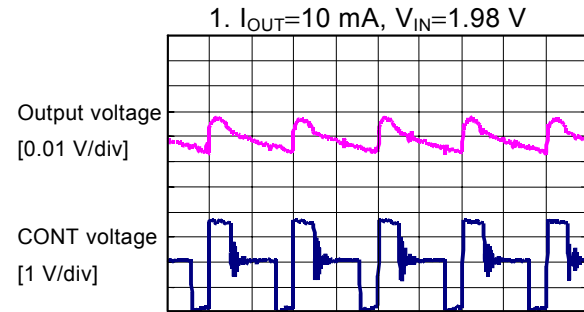

t [10 $\mu\text{s/div}$]

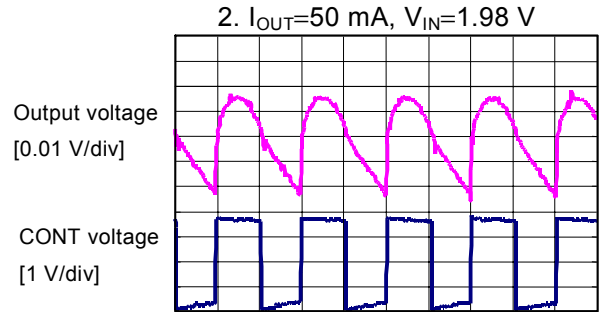

t [10 $\mu\text{s/div}$]

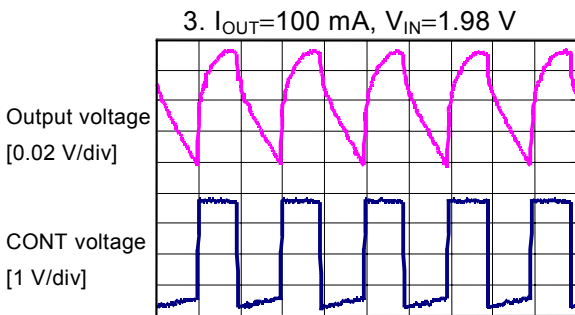

t [10 $\mu\text{s/div}$]

2. S-8354H33

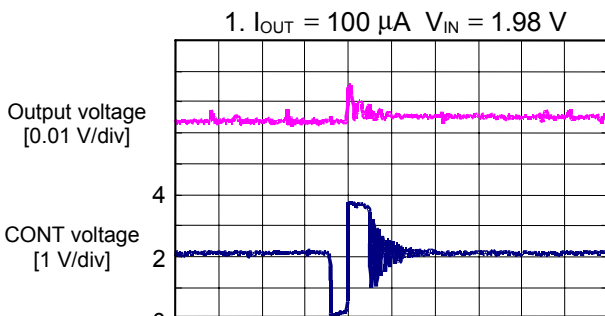

t [2 $\mu\text{s/div}$]

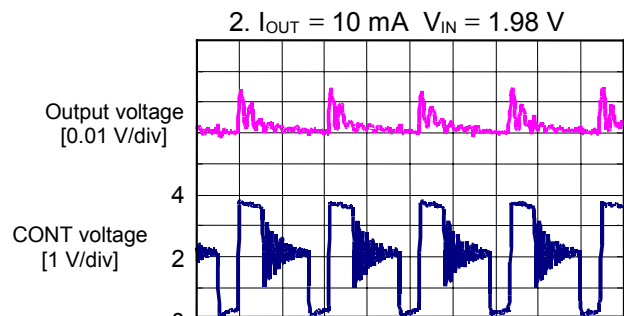

t [2 $\mu\text{s/div}$]

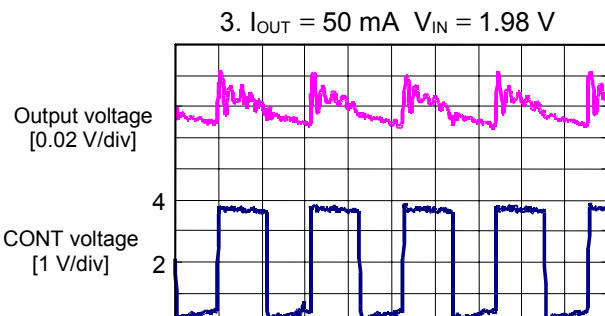

t [2 $\mu\text{s/div}$]

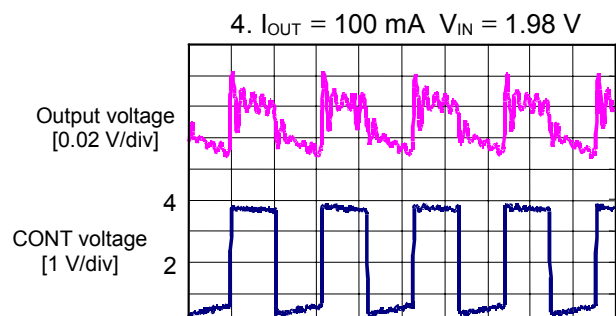

t [2 $\mu\text{s/div}$]

■ **Examples of Transient Response Characteristics (Ta=25°C) (S-8354H33)**

1. Power-On (V_{IN} ; 0 V → 2.0 V)

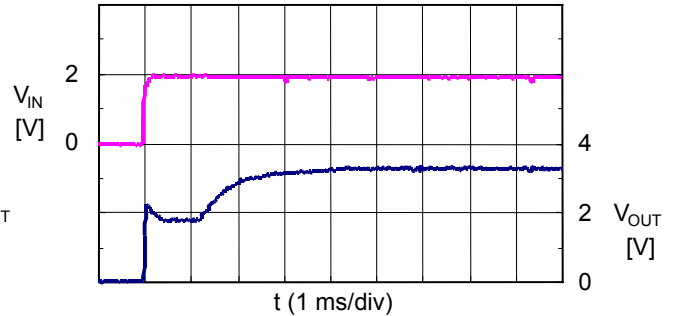
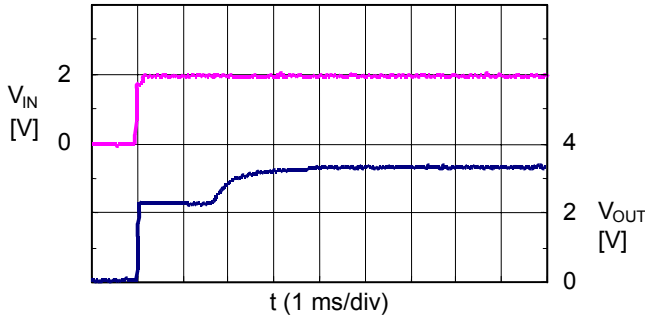

2. ON/OFF Pin Response ($V_{ON/OFF}$; 0 V → 2.0 V)

ON/OFF (250 kHz, $I_{OUT} = 1$ mA, $V_{IN} = 2$ V)

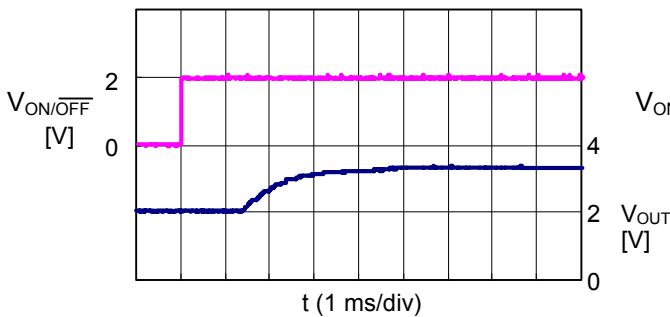

ON/OFF (250 kHz, $I_{OUT} = 50$ mA, $V_{IN} = 2$ V)

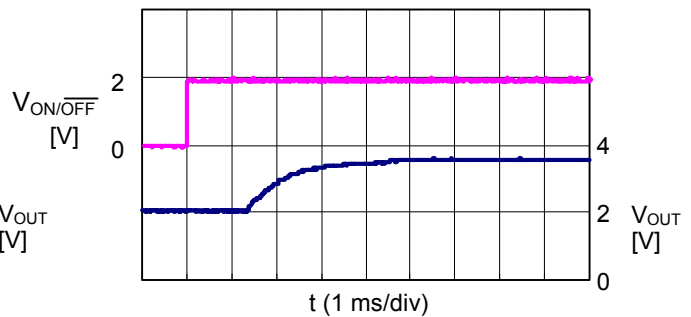

3. Load Fluctuations

Load Fluctuation

(250 kHz, I_{OUT} ; 100 μ A → 50 mA, $V_{IN} = 1.98$ V)

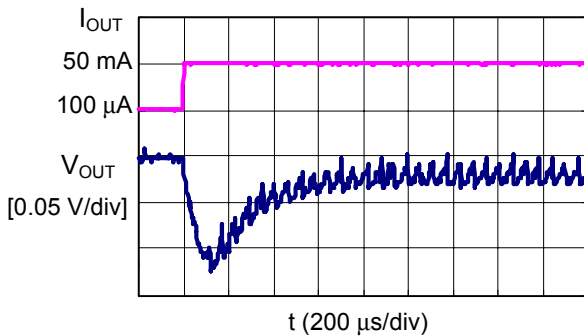

Load Fluctuation

(250 kHz, I_{OUT} ; 50 mA → 100 μ A, $V_{IN} = 1.98$ V)

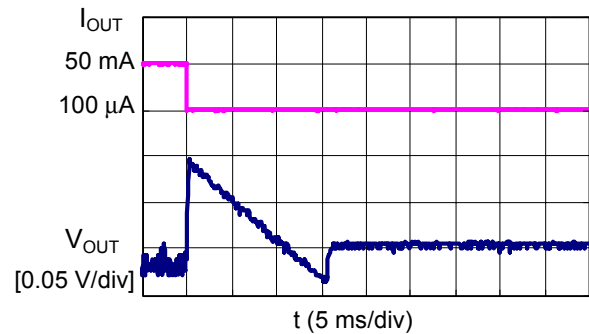

4. Input Voltage Fluctuations

Input voltage fluctuation (250 kHz, $I_{OUT} = 50$ mA)

$V_{IN} = 1.98$ V → 2.64 V

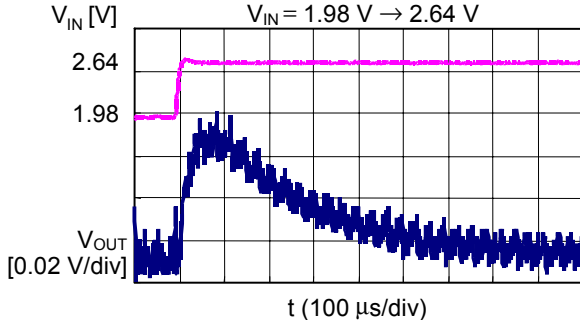

Input voltage fluctuation (250 kHz, $I_{OUT} = 50$ mA)

$V_{IN} = 2.64$ V → 1.98 V

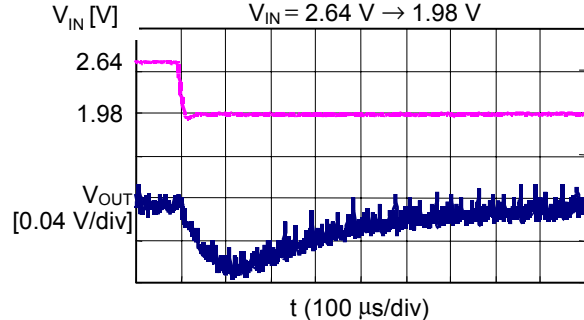

■ Reference Data

Reference data is provided to determine specific external components. Therefore, the following data shows the characteristics of the recommended external components selected for various applications.

1. Reference Data for External Components

Table 16 Efficiency vs. Output Characteristics and Output Voltage vs. Output Current Characteristics for External Components

No.	Product name	Oscillation frequency [kHz]	Output voltage [V]	Control system	Inductor	Diode	Output capacitor
1	S-8353H50MC	250	5.0	PWM	CDRH8D28-220	MA2Z748	F93 (16 V, 47 μF)
2	S-8353H50MC	250	5.0	PWM	CDRH5D28-220	MA2Z748	F93 (6.3 V, 22 μF)
3	S-8353H50MC	250	5.0	PWM	CXLP120-220	MA2Z748	F92 (6.3 V, 47 μF)
4	S-8354A50MC	50	5.0	PWM/PFM	CDRH8D28-101	MA2Z748	F93 (6.3 V, 22 μF)
5	S-8354A50MC	50	5.0	PWM/PFM	CXLP120-470	MA2Z748	F92 (6.3 V, 47 μF)
6	S-8353A50MC	50	5.0	PWM	CDRH8D28-101	MA2Z748	F93 (6.3 V, 22 μF)
7	S-8353A50MC	50	5.0	PWM	CXLP120-470	MA2Z748	F92 (6.3 V, 47 μF)
8	S-8353A33MC	50	3.3	PWM	CDRH8D28-101	MA2Z748	F93 (6.3 V, 22 μF)

The performance of the external components is shown below.

Table 17 Properties of External Components

Component	Product name	Manufacturer	Characteristics
Inductor	CDRH8D28-220	Sumida Corporation	22 μH, DCR ^{*1} =95 mΩ, I _{max.} ^{*2} =1.6 A, Component height=3.0 mm
	CDRH8D28-101		100 μH, DCR ^{*1} =410 mΩ, I _{max.} ^{*2} =0.75 A, Component height =3.0 mm
	CDRH5D28-220		22 μH, DCR ^{*1} =122 mΩ, I _{max.} ^{*2} =0.9 A, Component height =3.0 mm
	CXLP120-220	Sumitomo Special Metals Co., Ltd.	22 μH, DCR ^{*1} =590 mΩ, I _{max.} ^{*2} =0.55 A, Component height =1.2 mm
	CXLP120-470		47 μH, DCR ^{*1} =950 mΩ, I _{max.} ^{*2} =0.45 A, Component height =1.2 mm
Diode	MA2Z748	Matsushita Electric Industrial Co., Ltd,	V _F ^{*3} =0.4 V, I _F ^{*4} =0.3 A
Capacitor	F93 (16 V, 47 μF)	Nichicon Corporation	—
	F93 (6.3 V, 22 μF)		—
	F92 (6.3 V, 47 μF)		—

- *1. DC resistance
- *2. Maximum allowable current
- *3. Forward voltage
- *4. Forward current

Caution The values shown in the characteristics column of Table 17 above are based on the materials provided by each manufacturer, however, consider the characteristics of the original materials when using the above products.

2. Reference Data (1)

The following shows the actual (a) Output current vs. Efficiency characteristics and (b) Output current vs. Output voltage characteristics under the conditions of No. 1 to 8 in **Table 16**.

(1) S-8353H50MC

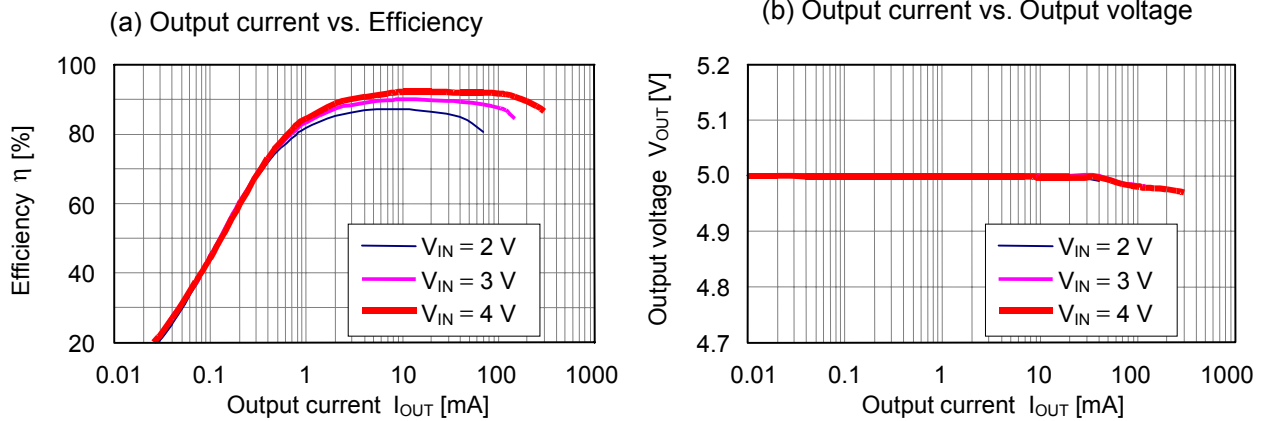

(2) S-8353H50MC

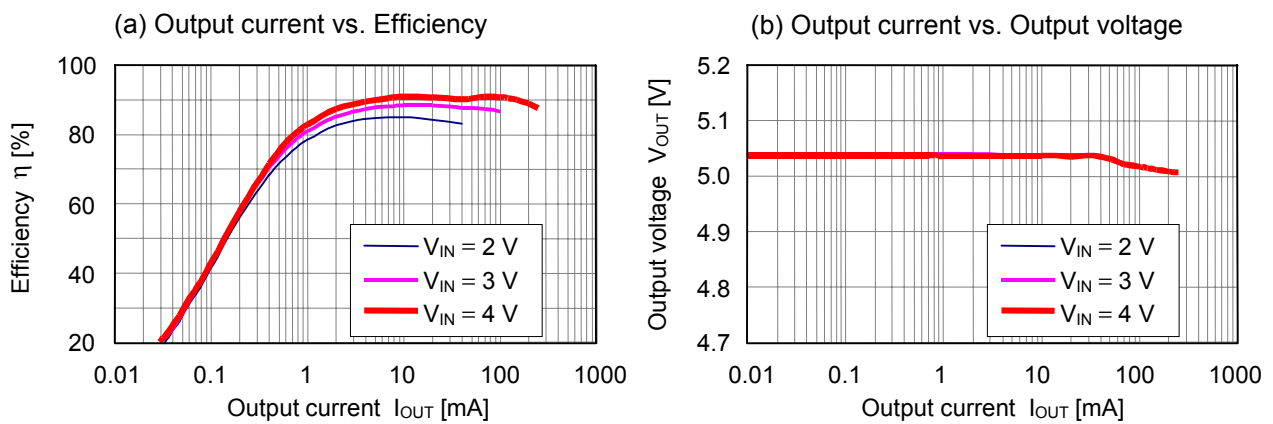

(3) S-8353H50MC

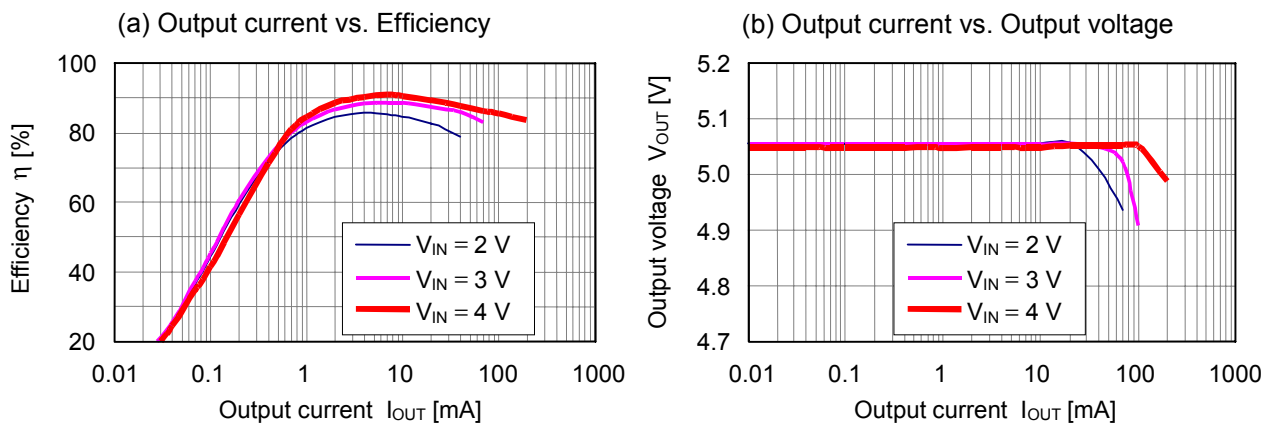

(4) S-8354A50MC

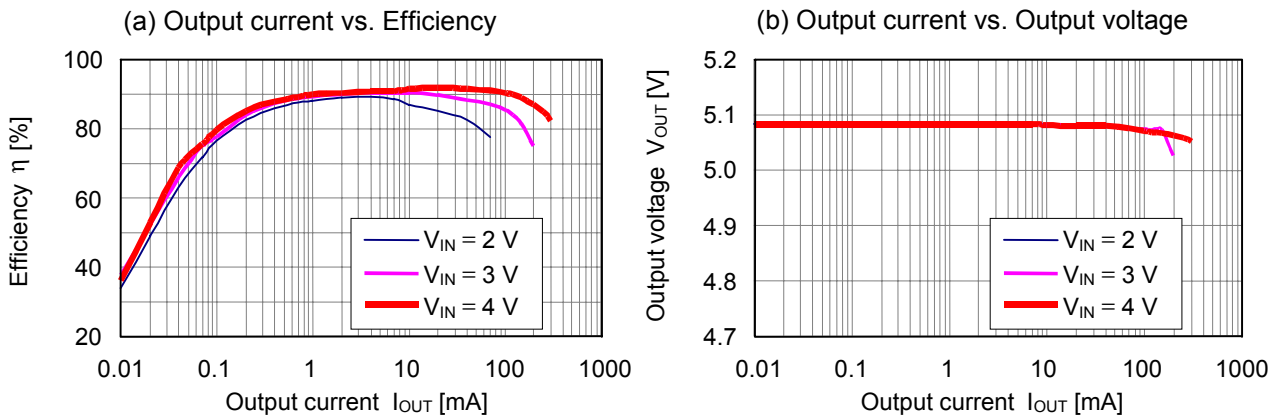

(5) S-8354A50MC

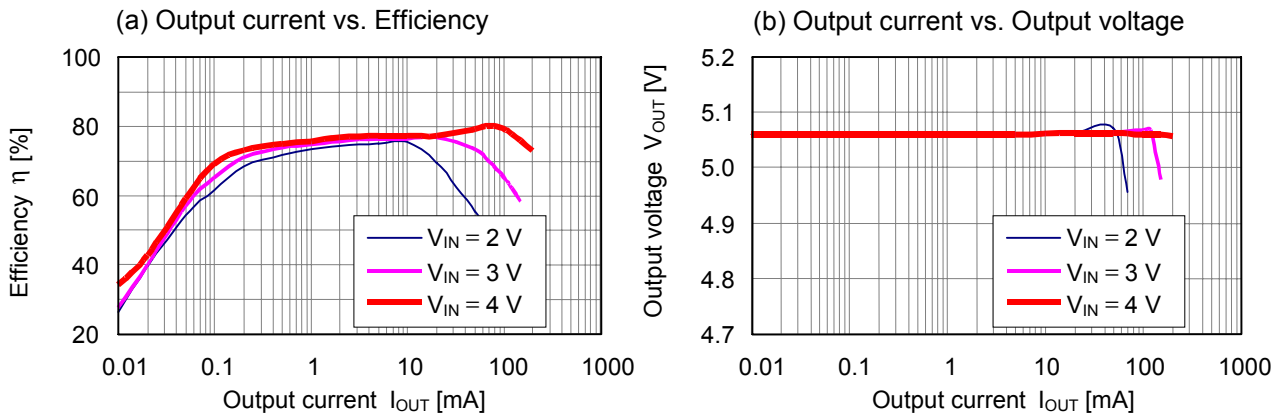

(6) S-8353A50MC

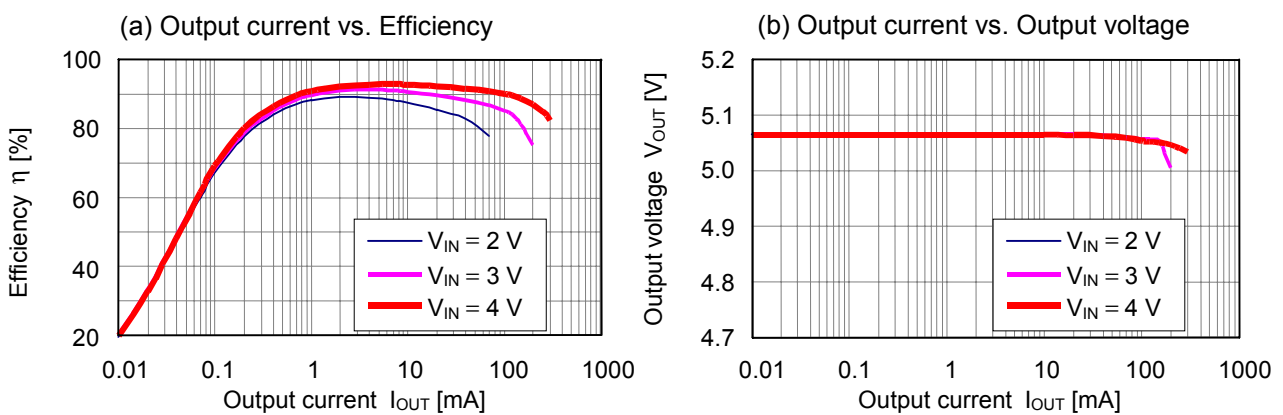

(7) S-8353A50MC

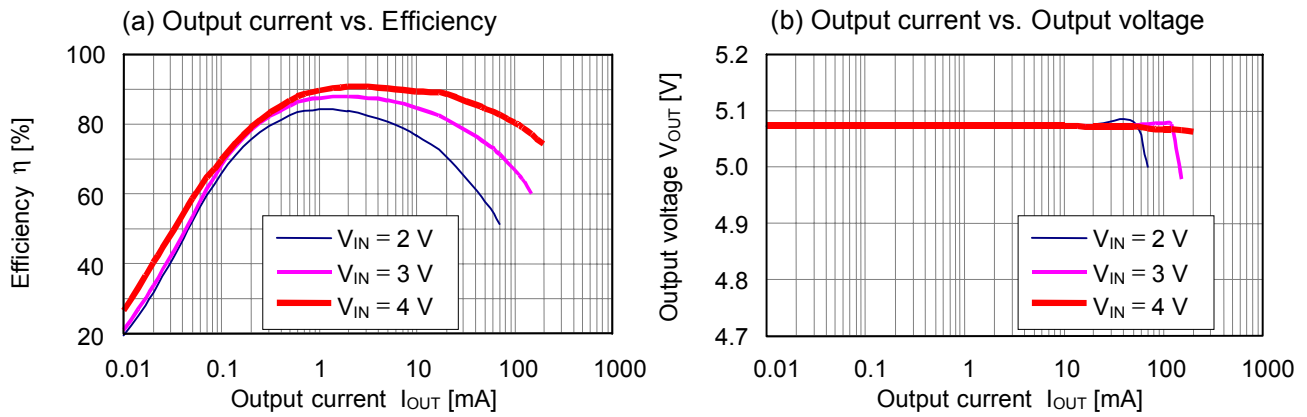

(8) S-8354A33MC

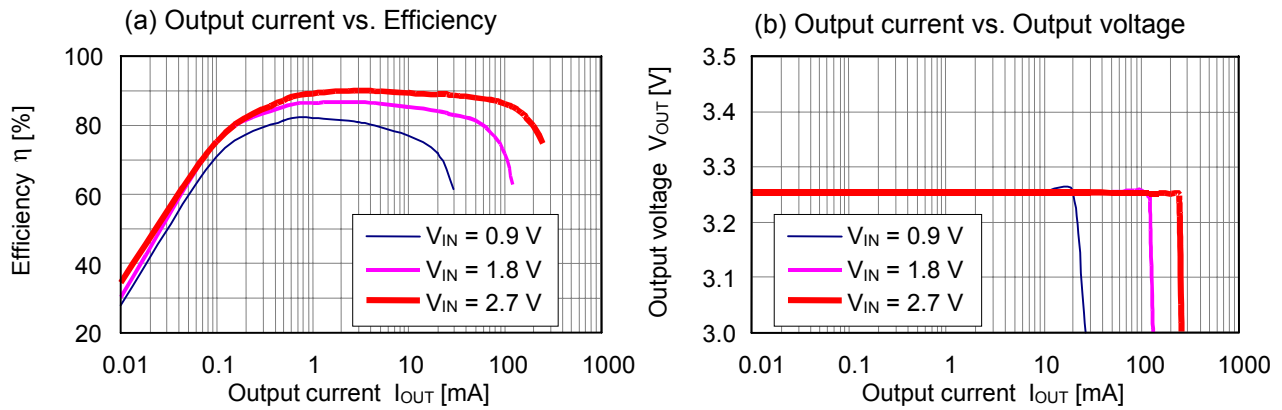

3. Reference Data (2)

The following shows the actual output current vs. ripple voltage characteristics under the conditions of No. 1 to 8 in **Table 16**.

(1) S-8353H50MC

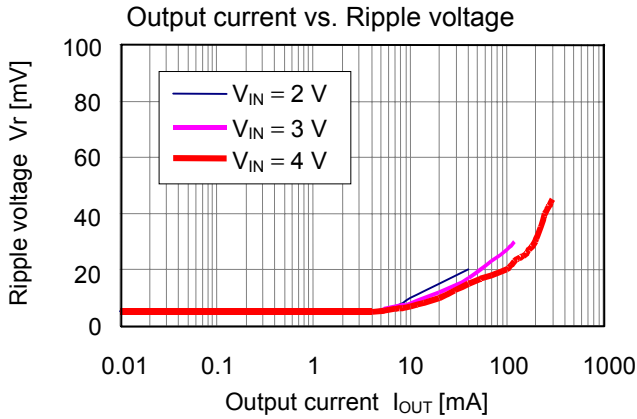

(2) S-8353H50MC

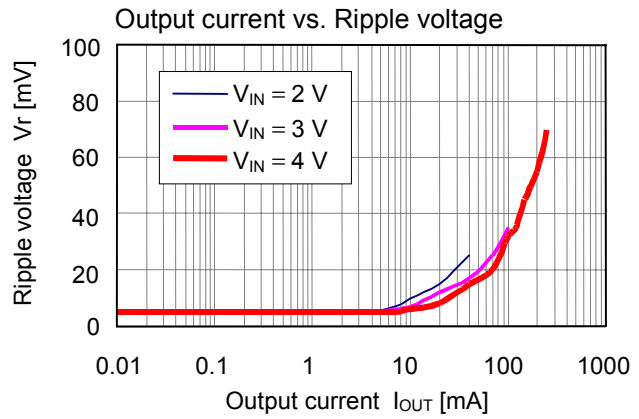

(3) S-8353H50MC

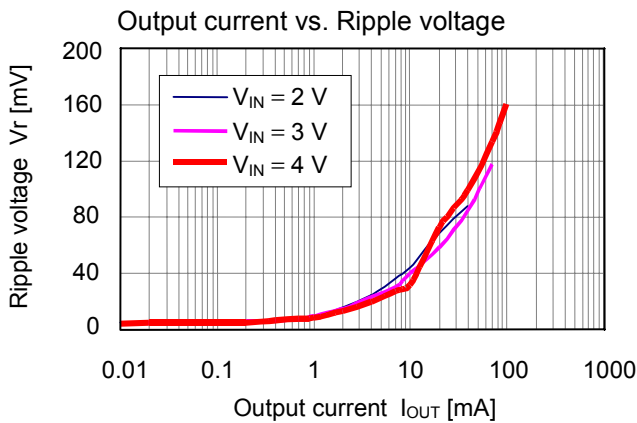

(4) S-8354A50MC

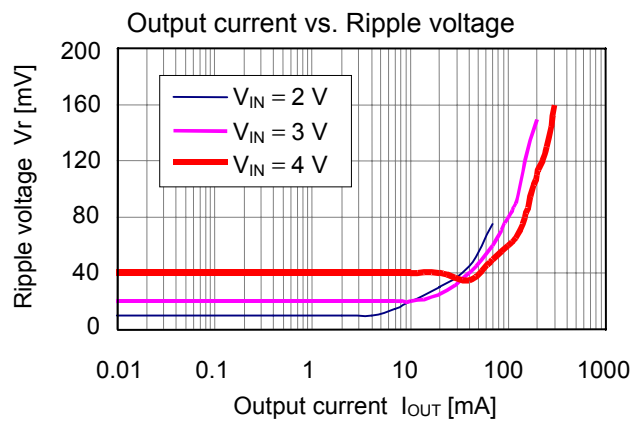

(5) S-8354A50MC

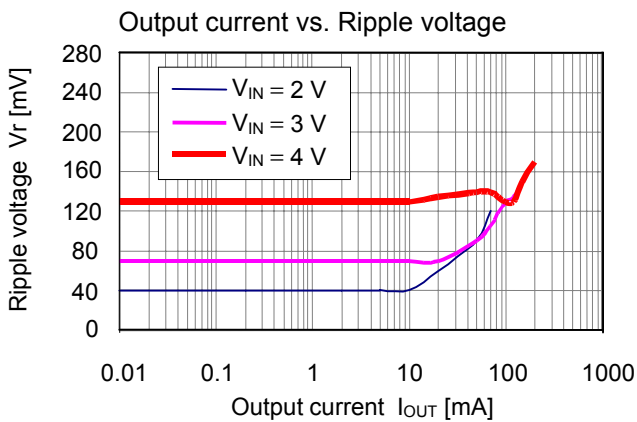

(6) S-8353A50MC

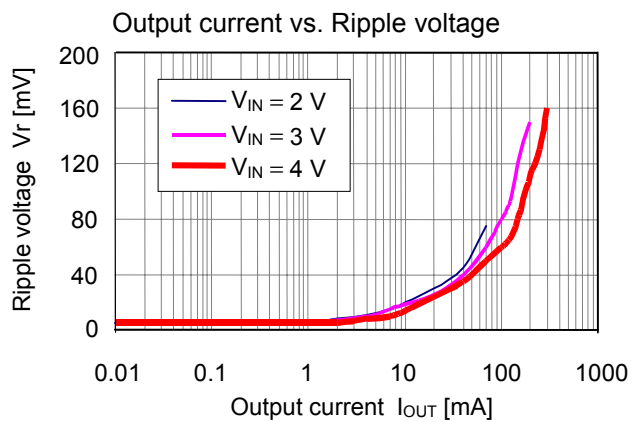

(7) S-8353A50MC

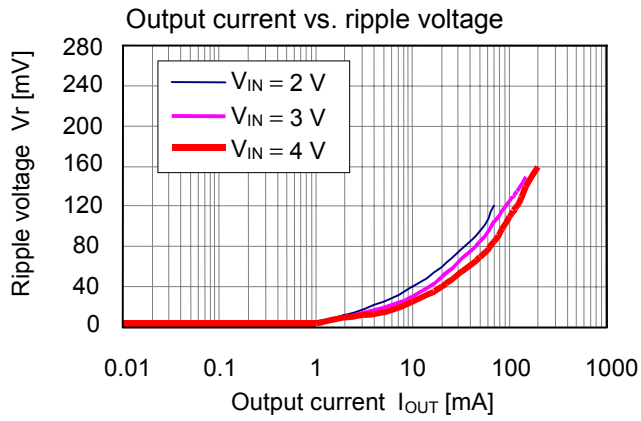

(8) S-8353A33MC

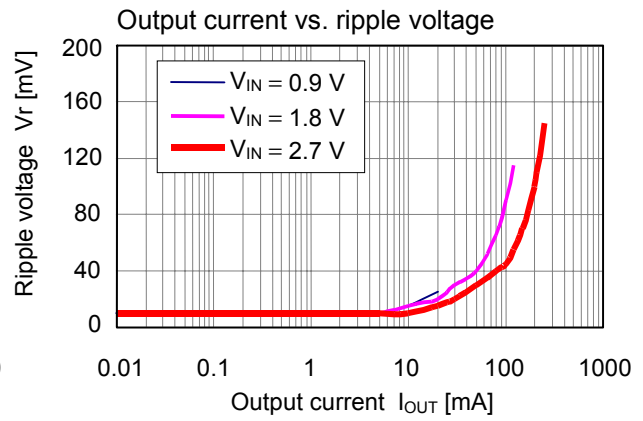

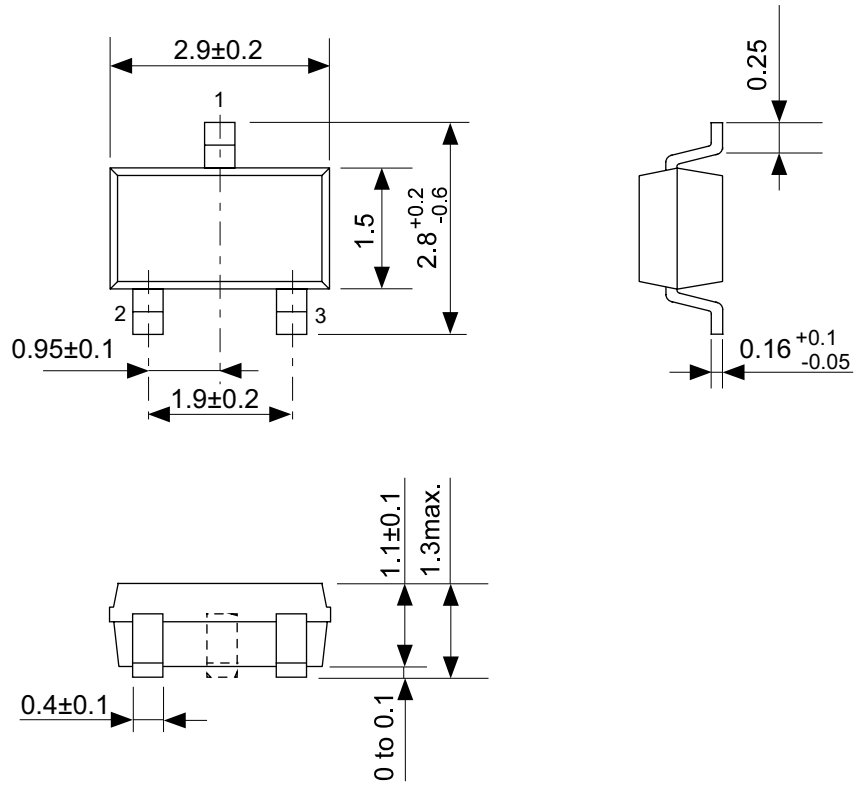

No. MP003-A-P-SD-1.1

TITLE	SOT233-A-PKG Dimensions
No.	MP003-A-P-SD-1.1
SCALE	
UNIT	mm
Seiko Instruments Inc.	

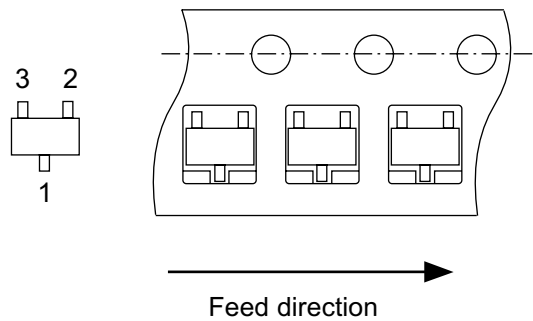
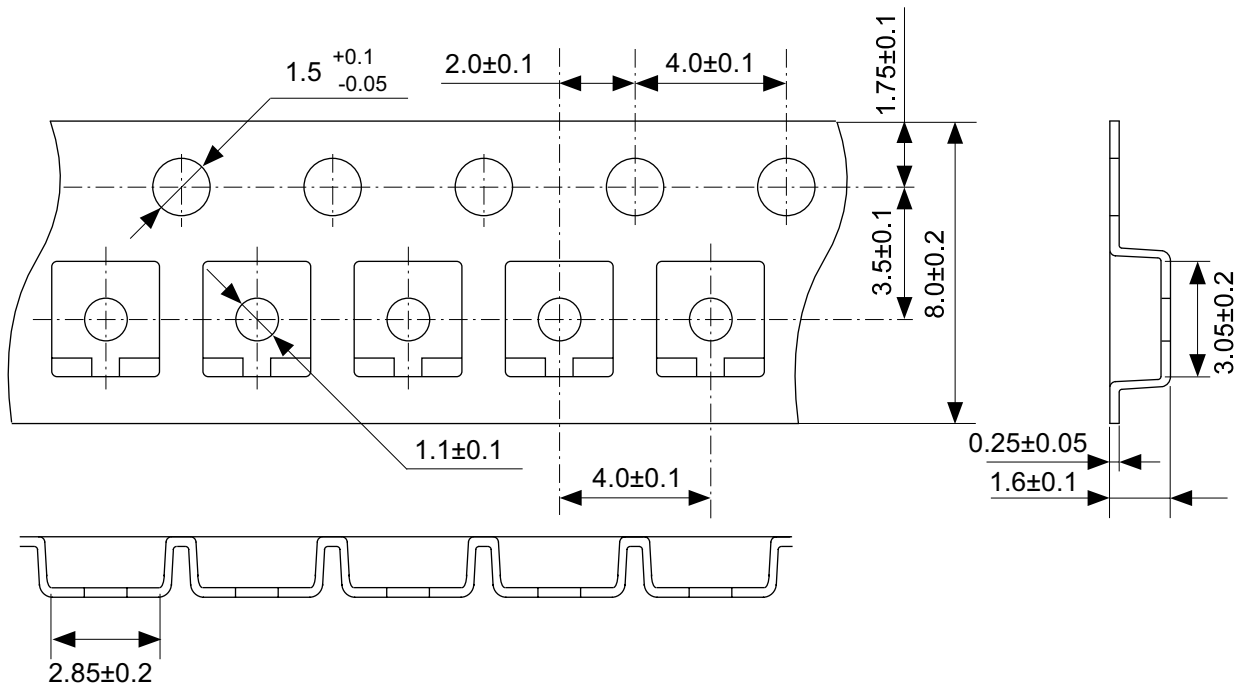

No. MP003-A-C-SD-1.1

TITLE	SOT233-A-Carrier Tape
No.	MP003-A-C-SD-1.1
SCALE	
UNIT	mm
Seiko Instruments Inc.	

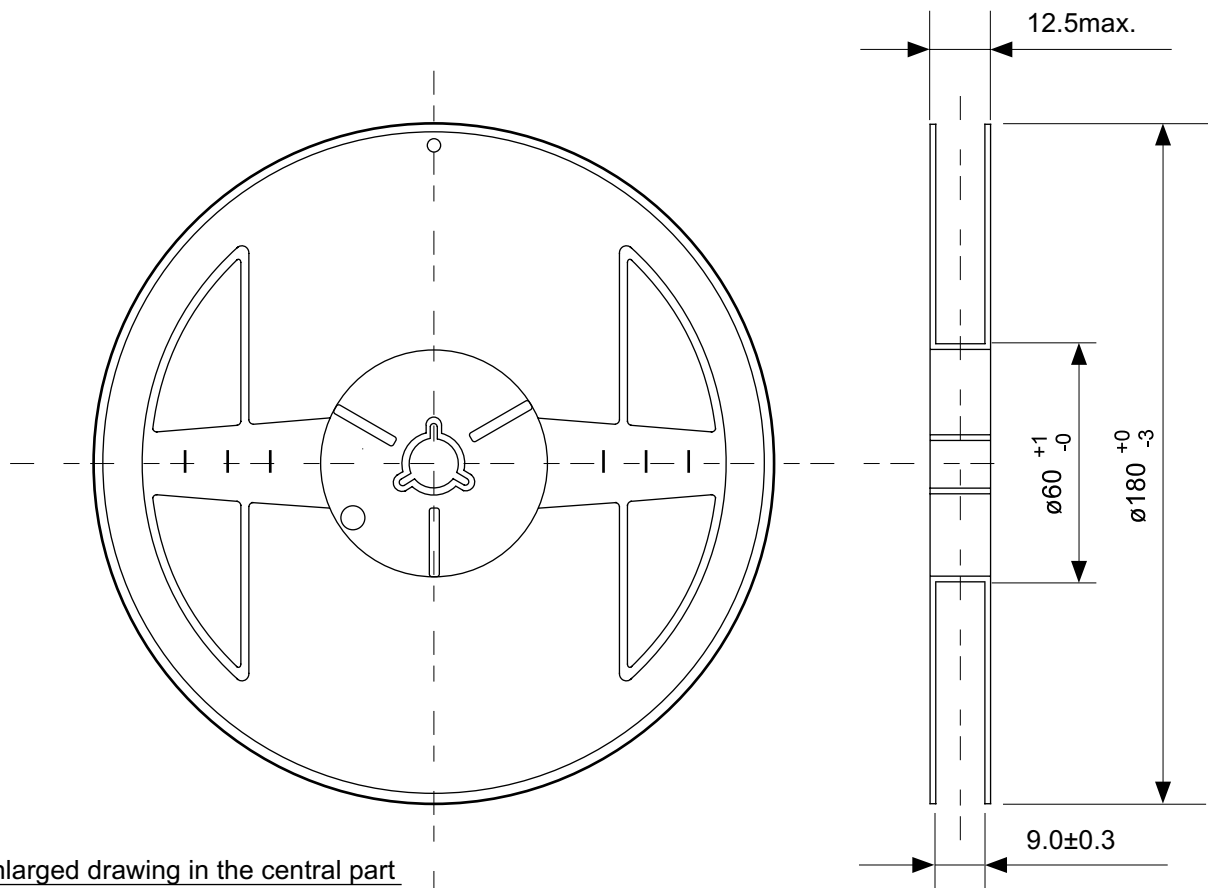

Enlarged drawing in the central part

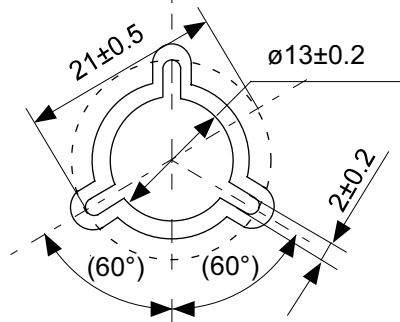

No. MP003-A-R-SD-1.1

TITLE	SOT233-A-Reel		
No.	MP003-A-R-SD-1.1		
SCALE		QTY.	3,000
UNIT	mm		
Seiko Instruments Inc.			

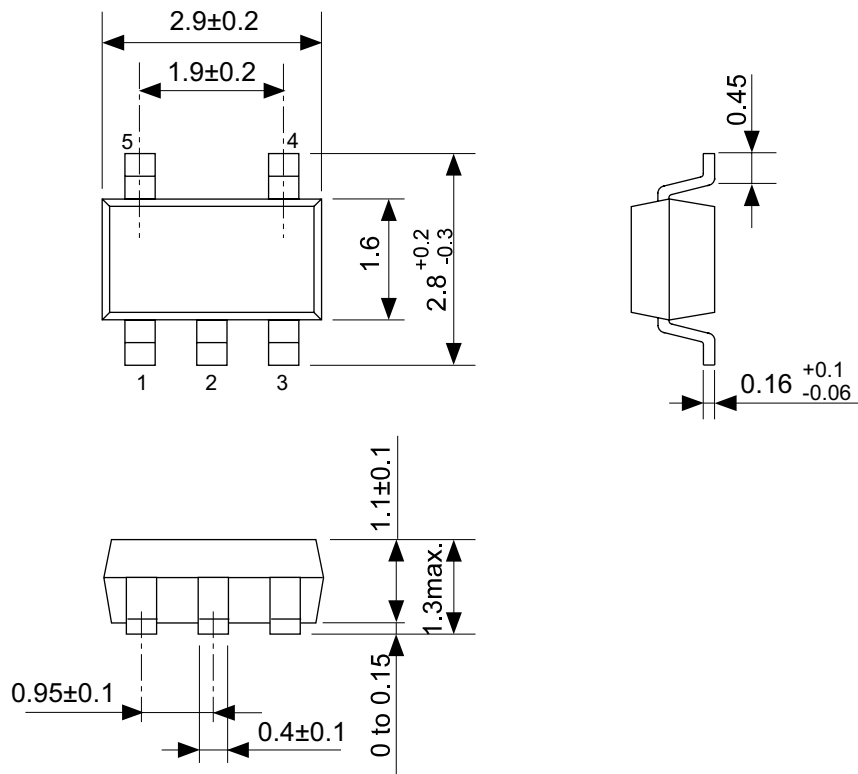

No. MP005-A-P-SD-1.2

TITLE	SOT235-A-PKG Dimensions
No.	MP005-A-P-SD-1.2
SCALE	
UNIT	mm
Seiko Instruments Inc.	

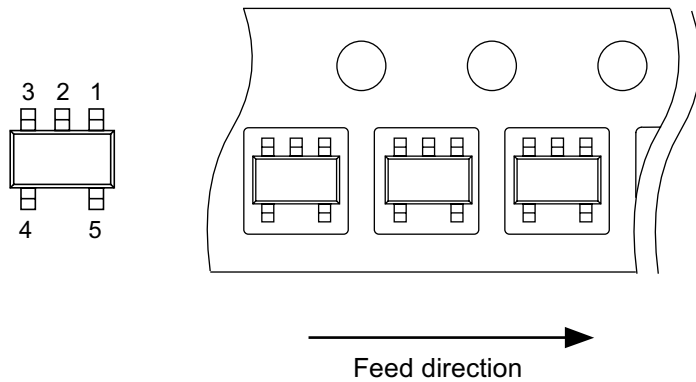
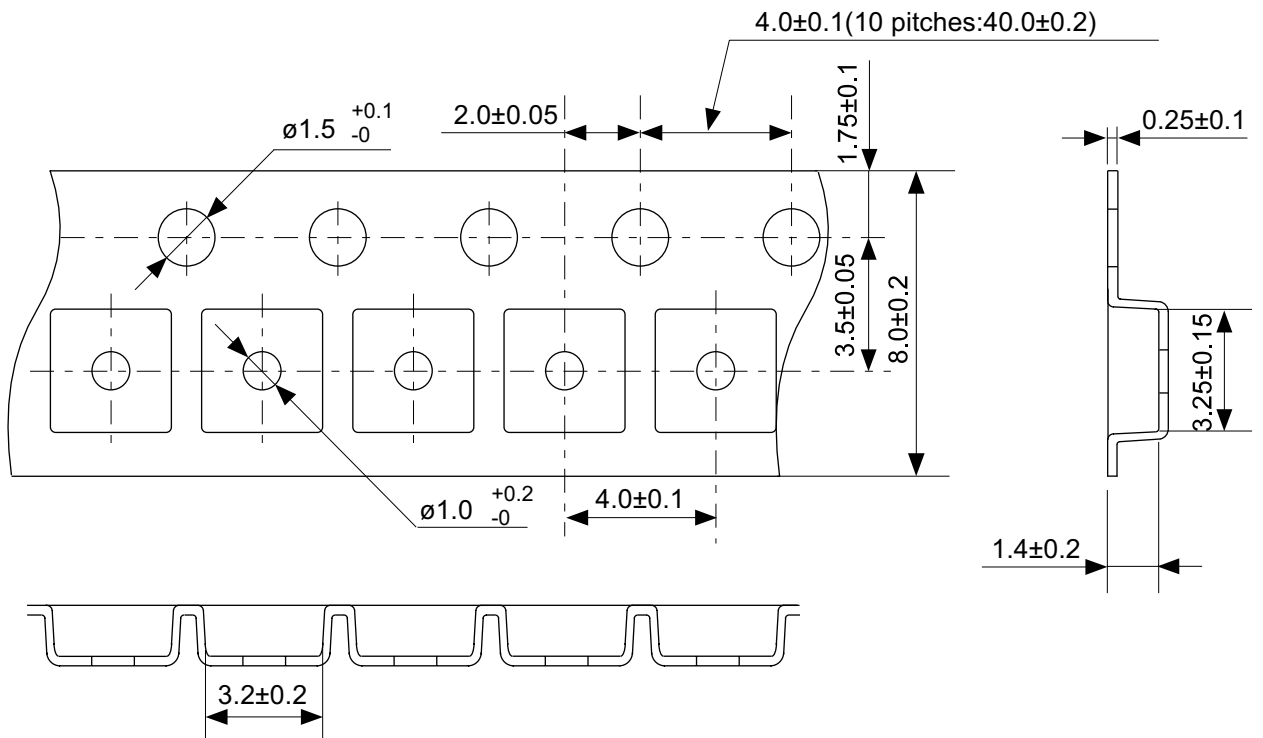

No. MP005-A-C-SD-2.1

TITLE	SOT235-A-Carrier Tape
No.	MP005-A-C-SD-2.1
SCALE	
UNIT	mm
Seiko Instruments Inc.	

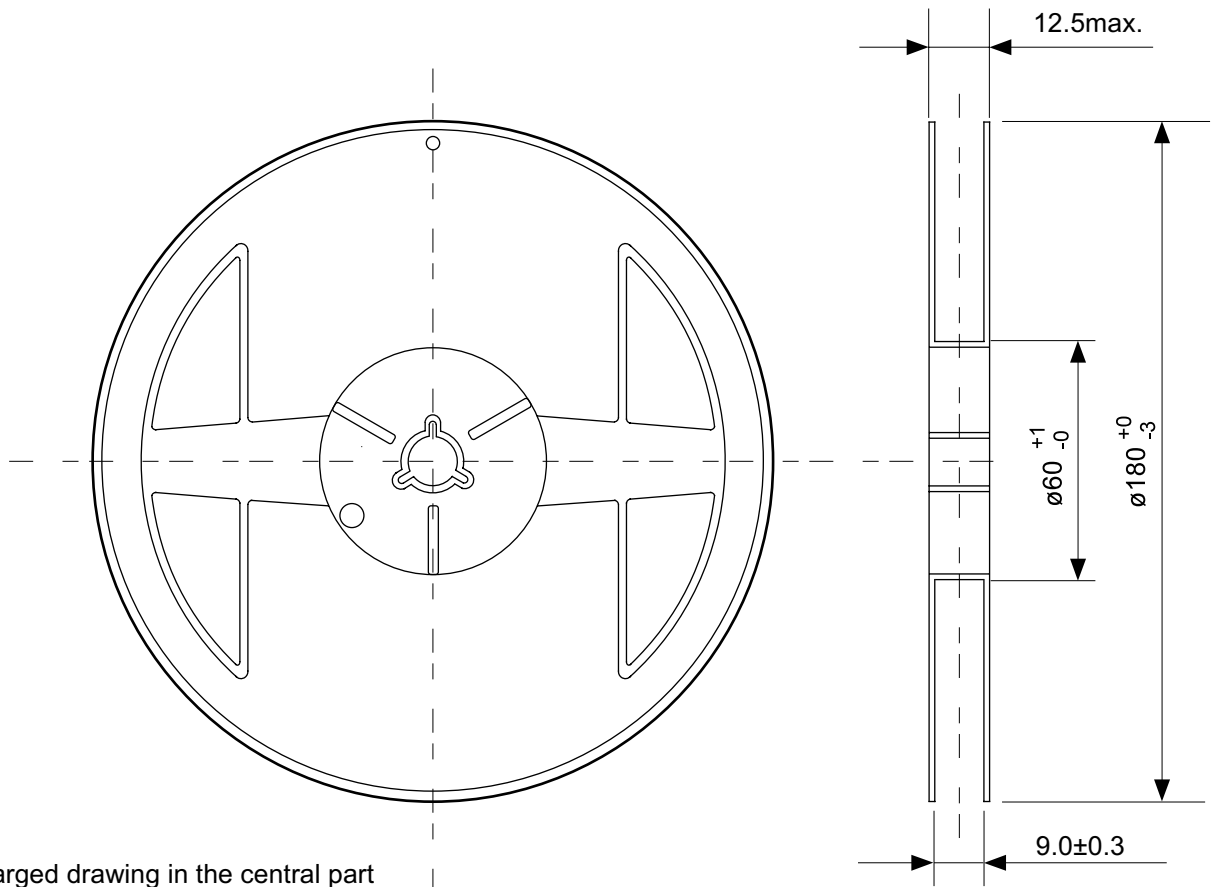

Enlarged drawing in the central part

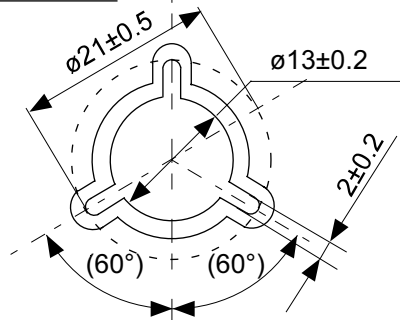

No. MP005-A-R-SD-1.1

TITLE	SOT235-A-Reel		
No.	MP005-A-R-SD-1.1		
SCALE		QTY.	3,000
UNIT	mm		
Seiko Instruments Inc.			

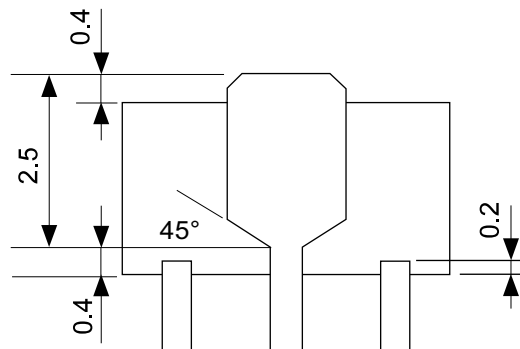
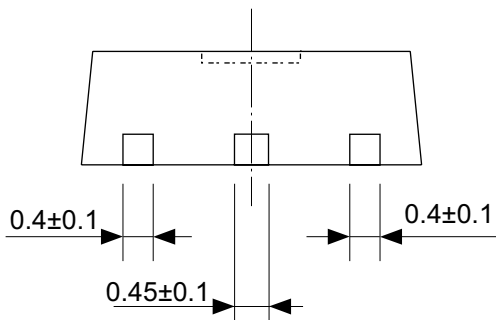
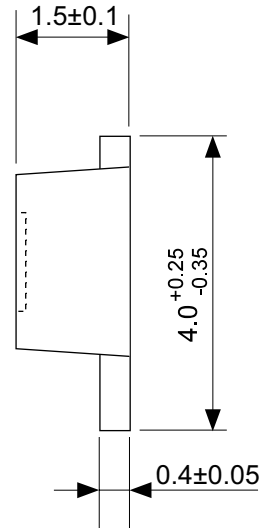
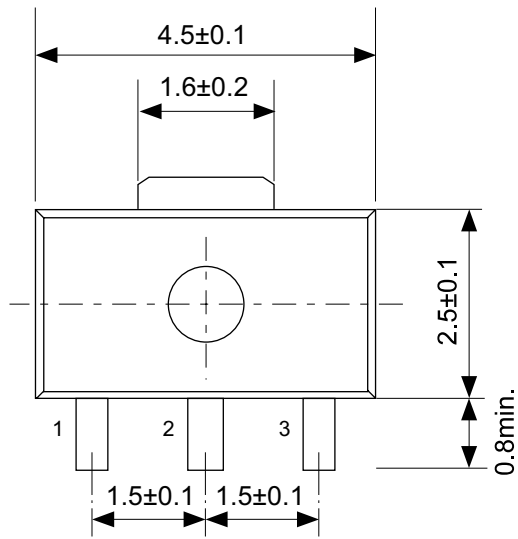

No. UP003-A-P-SD-1.1

TITLE	SOT893-A-PKG Dimensions
No.	UP003-A-P-SD-1.1
SCALE	
UNIT	mm
Seiko Instruments Inc.	

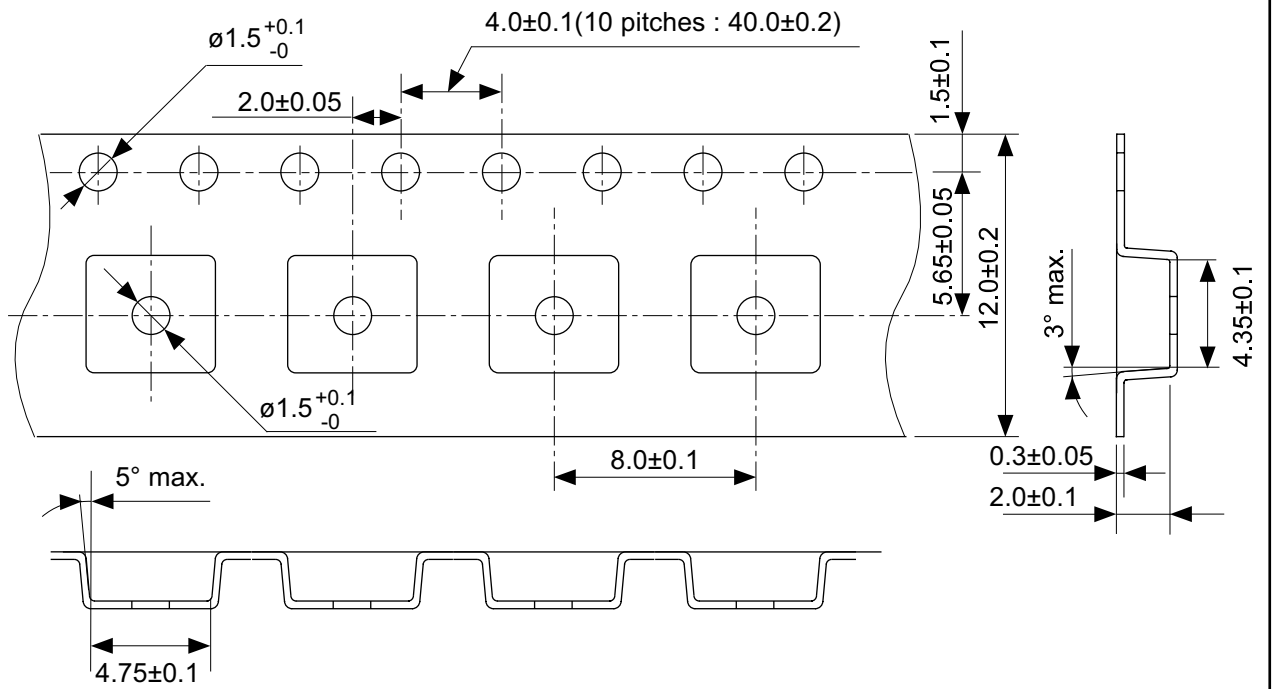

→
Feed direction

No. UP003-A-C-SD-1.1

TITLE	SOT893-A-Carrier Tape
No.	UP003-A-C-SD-1.1
SCALE	
UNIT	mm
Seiko Instruments Inc.	

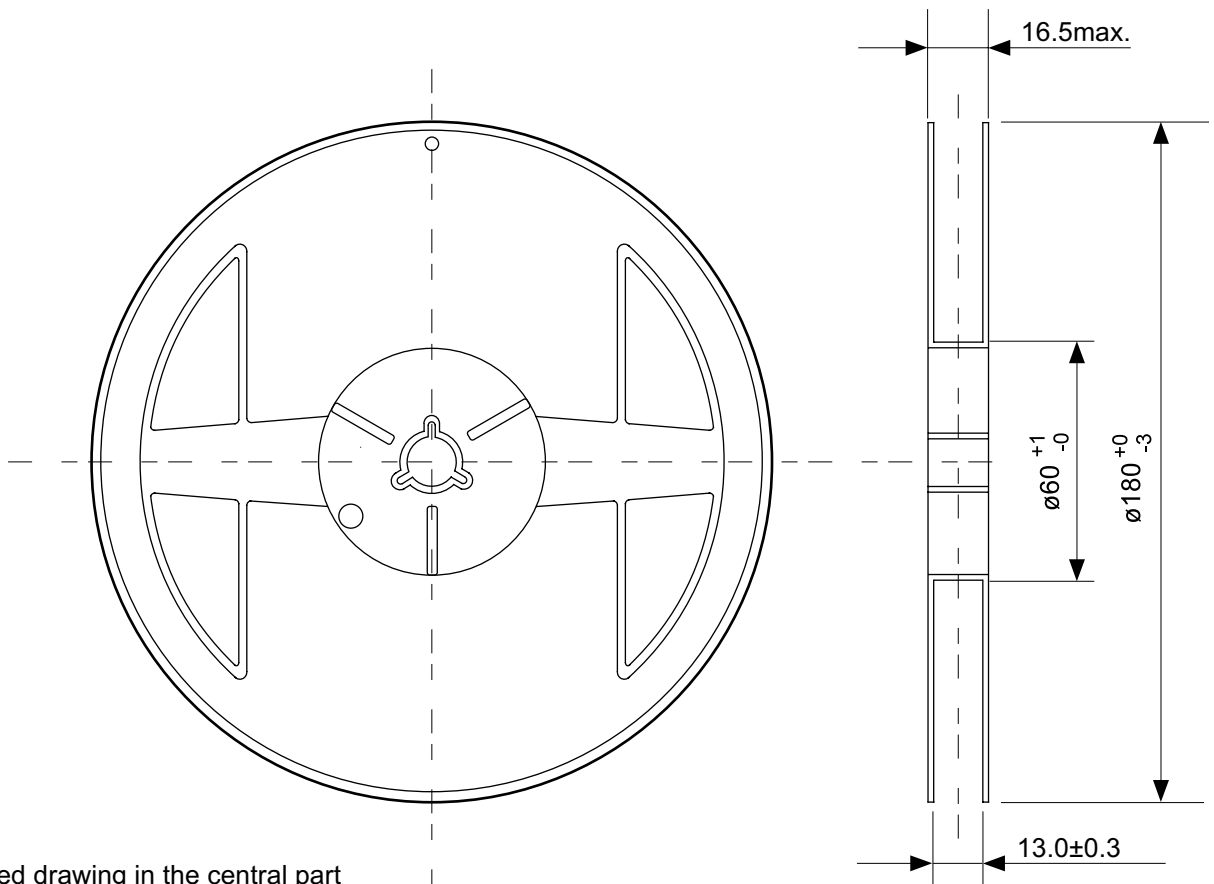

Enlarged drawing in the central part

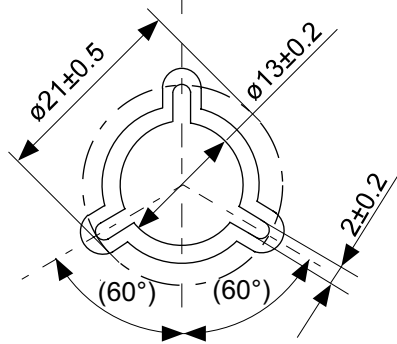

No. UP003-A-R-SD-1.1

TITLE	SOT893-A-Reel		
No.	UP003-A-R-SD-1.1		
SCALE		QTY.	1,000
UNIT	mm		

Seiko Instruments Inc.

- The information described herein is subject to change without notice.
- Seiko Instruments Inc. is not responsible for any problems caused by circuits or diagrams described herein whose related industrial properties, patents, or other rights belong to third parties. The application circuit examples explain typical applications of the products, and do not guarantee the success of any specific mass-production design.
- When the products described herein are regulated products subject to the Wassenaar Arrangement or other agreements, they may not be exported without authorization from the appropriate governmental authority.
- Use of the information described herein for other purposes and/or reproduction or copying without the express permission of Seiko Instruments Inc. is strictly prohibited.
- The products described herein cannot be used as part of any device or equipment affecting the human body, such as exercise equipment, medical equipment, security systems, gas equipment, or any apparatus installed in airplanes and other vehicles, without prior written permission of Seiko Instruments Inc.
- Although Seiko Instruments Inc. exerts the greatest possible effort to ensure high quality and reliability, the failure or malfunction of semiconductor products may occur. The user of these products should therefore give thorough consideration to safety design, including redundancy, fire-prevention measures, and malfunction prevention, to prevent any accidents, fires, or community damage that may ensue.