



Microcomputer Components

8-bit CMOS Microcontroller

C513AO

Data Sheet 02.00

<http://www.infineon.com/>

C513AO Data Sheet		
Revision History :		Current Version: 02.00
Previous Releases:		(Original Version)

For questions on technology, delivery and prices please contact the Infineon Technologies Offices in Germany or the Infineon Technologies Companies and Representatives worldwide:
see our webpage at <http://www.infineon.com>

Enhanced Hooks Technology™ is a trademark and patent of Metalink Corporation licensed to Infineon Technologies.

Edition 02.00

**Published by Infineon Technologies AG,
St.-Martin-Strasse 53,
D-81541 München**

**© Infineon Technologies AG 2000.
All Rights Reserved.**

Attention please!

The information herein is given to describe certain components and shall not be considered as warranted characteristics.

Terms of delivery and rights to technical change reserved.

We hereby disclaim any and all warranties, including but not limited to warranties of non-infringement, regarding circuits, descriptions and charts stated herein.

Infineon Technologies is an approved CECC manufacturer.

Information

For further information on technology, delivery terms and conditions and prices please contact your nearest Infineon Technologies Office in Germany or our Infineon Technologies Representatives worldwide (see address list).

Warnings

Due to technical requirements components may contain dangerous substances. For information on the types in question please contact your nearest Infineon Technologies Office.

Infineon Technologies Components may only be used in life-support devices or systems with the express written approval of Infineon Technologies, if a failure of such components can reasonably be expected to cause the failure of that life-support device or system, or to affect the safety or effectiveness of that device or system. Life support devices or systems are intended to be implanted in the human body, or to support and/or maintain and sustain and/or protect human life. If they fail, it is reasonable to assume that the health of the user or other persons may be endangered.

Advance Information

- Full upward compatibility with standard 8051 microcontroller
- Up to 16 MHz external operating frequency
 - 750 ns instruction cycle at 16 MHz operation
- On-chip program memory
 - C513AO-2R: 16 Kbytes ROM (with optional ROM protection)
 - C513AO-2E: 16 Kbytes OTP
 - C513AO-L: version without on-chip program memory (ROMless)
- Up to 64K byte external data memory
- 256 × 8 RAM
- 256 × 8 XRAM
- Four 8-bit digital I/O ports
- Three 16-bit timers/counters (Timer 2 with Up/Down and 16-bit auto-reload features)
- Full duplex serial interface (USART)
- Synchronous Serial Channel (SSC)
- Seven interrupt sources with two priority levels
- On-chip emulation support logic (Enhanced Hooks Emulation Technology™)

(further features are on next page)

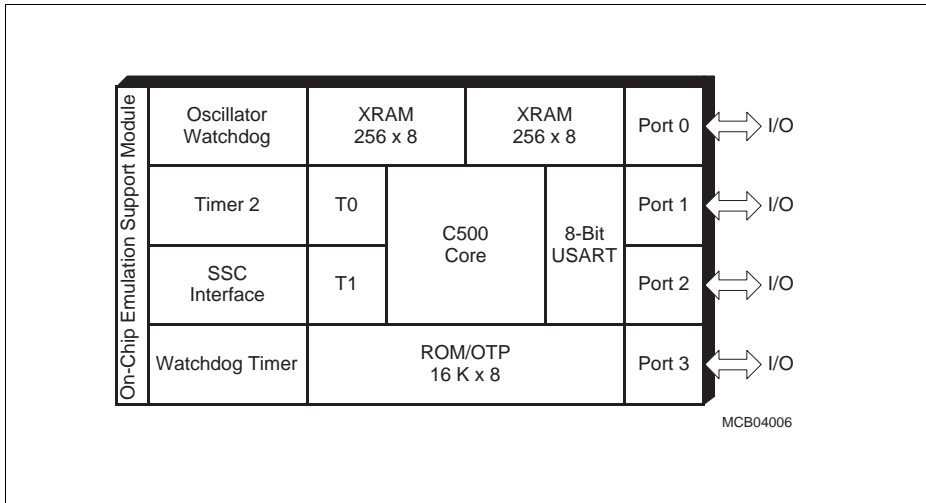

Figure 1
C513AO Functional Units

Features (continued):

- Programmable 15-bit Watchdog Timer
- Oscillator Watchdog
- Fast Power On Reset
- Power Saving Modes
 - Slow-down mode
 - Idle mode
 - Software power-down mode with optional wake up capability through pin P3.2/ $\overline{\text{INT0}}$
- Available in P-DIP40-2, P-LCC-44-1 and P-MQFP-44-2 packages
- Fully pin-compatible with C501, C504, C505C, C505CA and C511/C513-devices.
- Temperature ranges: SAB-C513AO T_A : 0 to 70 °C
SAF-C513AO T_A : – 40 to 85 °C

Ordering Information

The ordering code for Siemens microcontrollers provides an exact reference to the required product. This ordering code identifies:

- the derivative itself, i.e. its function set
- the specified temperature range
- the package and the type of delivery

For the available ordering codes for the C513AO please refer to the “**Product Information Microcontrollers**”, which summarizes all available microcontroller variants.

Note: The ordering codes for the Mask-ROM versions are defined for each product after the verification of the respective ROM code.

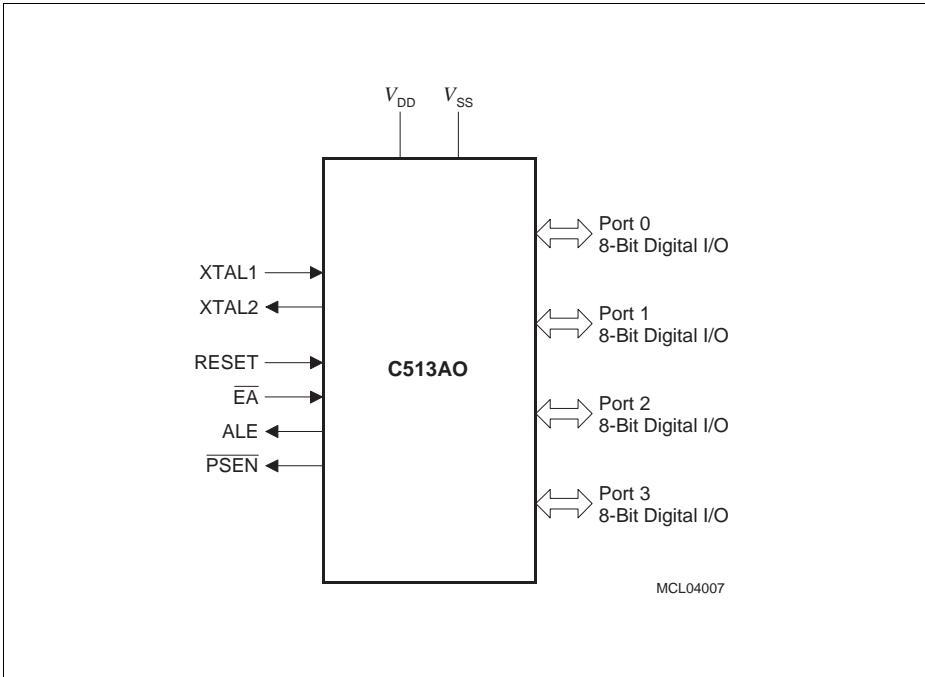

Figure 2
Logic Symbol

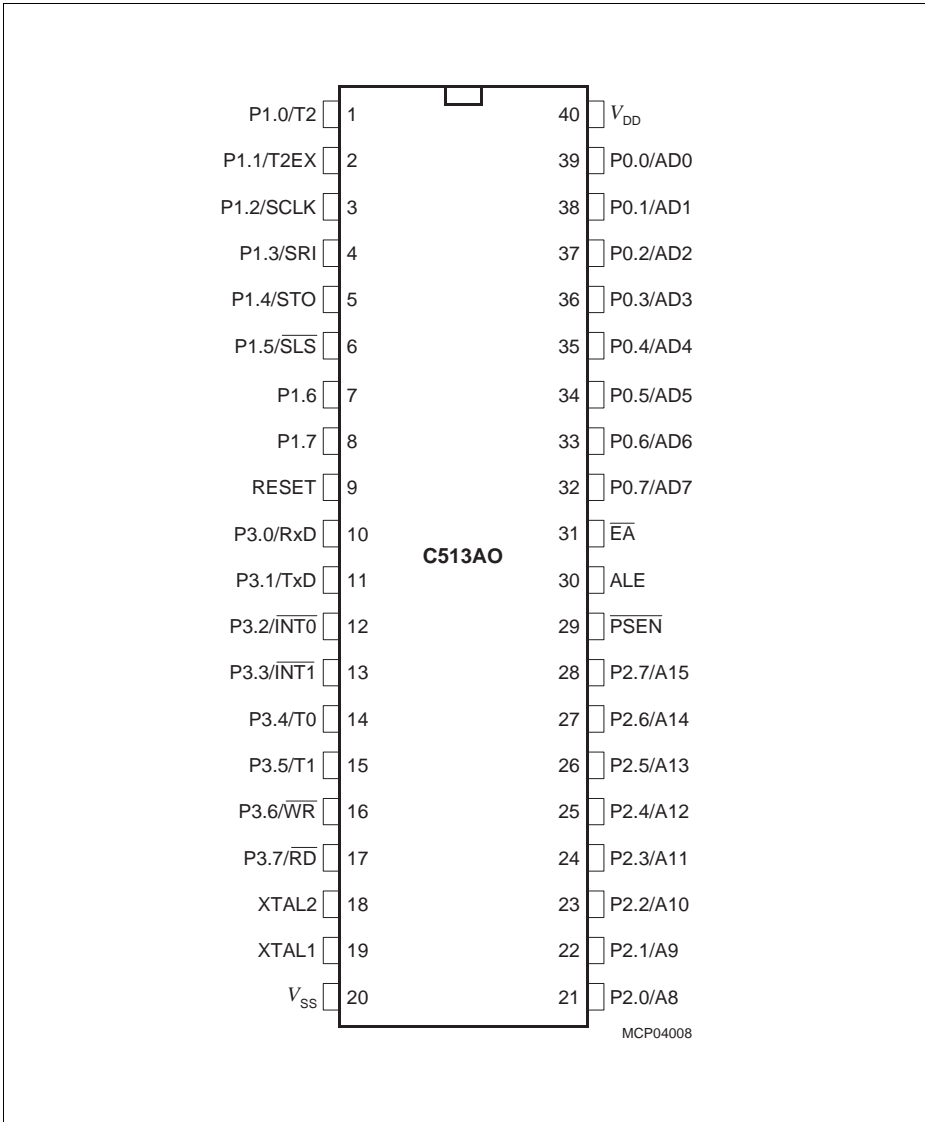

Figure 3
P-DIP-40-2 Package Pin Configuration (top view)

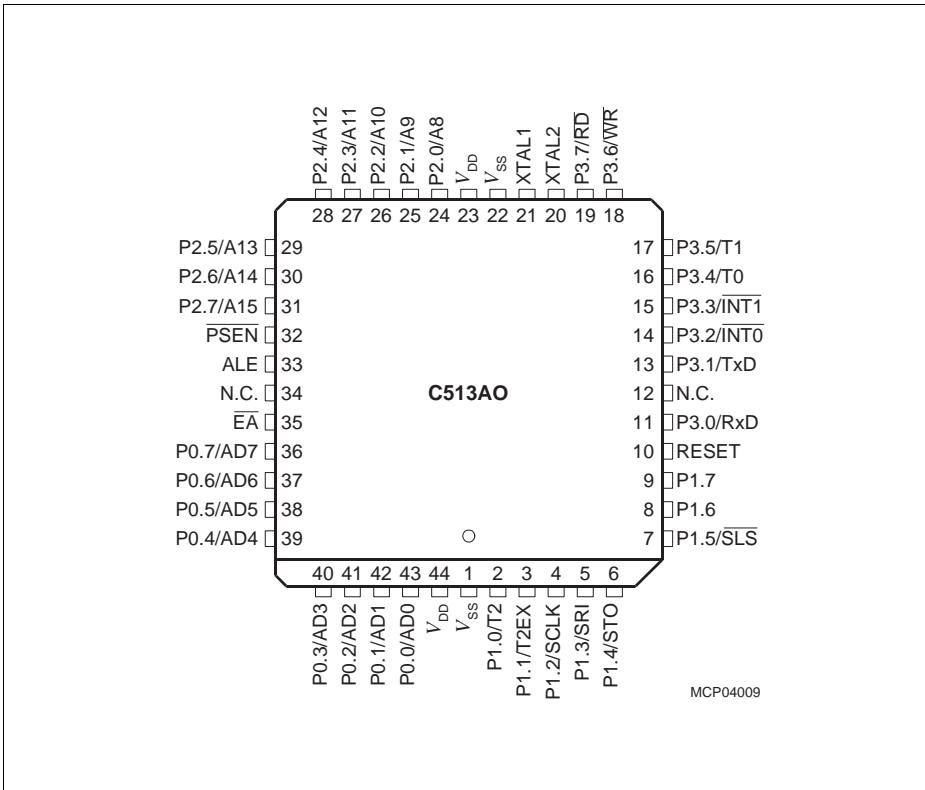

Figure 4
P-LCC-44-1 Package Pin Configuration (top view)

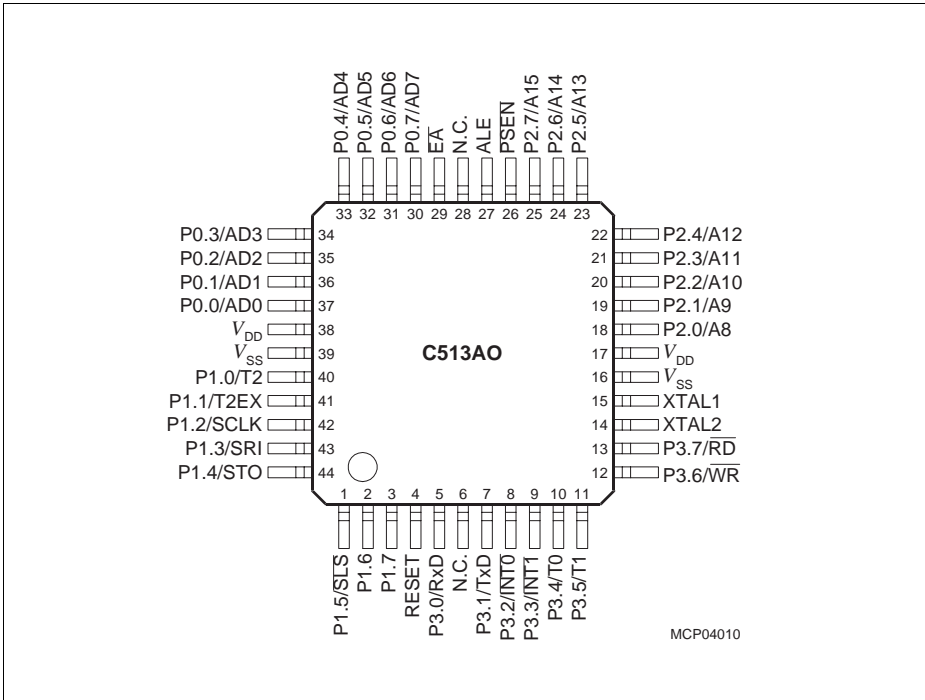

Figure 5
P-MQFP-44-2 Package Pin Configuration (top view)

Table 1
Pin Definitions and Functions

Symbol	Pin Number			I/O *)	Function
	P- DIP -40	P-LCC- 44	P-MQFP- 44		
P1.7- P1.0	8-1	9-2	3-1, 44-40	I/O	<p>Port 1</p> <p>Port 1 is an 8-bit quasi-bidirectional port with internal pull-up arrangement. Port 1 pins that have "1s" written to them are pulled high by the internal pull-up transistors and in that state can be used as inputs. As inputs, Port 1 pins being externally pulled low will source current (I_{IL}, in the DC characteristics) because of the internal pull-up transistors. The output latch corresponding to a secondary function must be programmed to 1 for that function to operate.</p> <p>For the outputs of the Synchronous Serial Channel (SSC), SCLK and STO, special circuitry is implemented providing true push-pull capability. The STO output, in addition, will have true tristate capability. When used for SSC inputs, the pull-up transistors will be switched off and the inputs float (high ohm inputs).</p> <p>The secondary functions are assigned to the pins of Port 1 as follows:</p>
	1	2	40		P1.0 / T2 Input to Counter 2
	2	3	41		P1.1 / T2EX Capture/reload trigger of Timer 2
	3	4	42		Up-Down count
	4	5	43		P1.2 / SCLK SSC Master Clock Output
	5	6	44		SSC Slave Clock Input
	6	7	1		P1.3 / SRI SSC Receive Input
					P1.4 / STO SSC Transmit Output
					P1.5 / \overline{SLS} Slave Select Input

*) I = Input
 O = Output

Table 1
Pin Definitions and Functions (cont'd)

Symbol	Pin Number			I/O)*)	Function																
	P-DIP -40	P-LCC- 44	P-MQFP- 44																		
P3.0- P.3.7	10-17	11, 13-19	5, 7-13	I/O	<p>Port 3</p> <p>Port 3 is an 8-bit quasi-bidirectional port with internal pull-up arrangement. Port 3 pins that have "1"s written to them are pulled high by the internal pull-up transistors and in that state can be used as inputs. As inputs, Port 3 pins being externally pulled low will source current (I_{IL}, in the DC characteristics) because of the internal pull-up transistors. The output latch corresponding to a secondary function must be programmed to a "1" for that function to operate (except for TxD and WR).</p> <p>The secondary functions are assigned to the pins of Port 3 as follows:</p> <table border="0"> <tr> <td>P3.0 / RxD</td> <td>Receiver data input (asynch.) or data input/output (synch.) of serial interface</td> </tr> <tr> <td>P3.1 / TxD</td> <td>Transmitter data output (asynch.) or clock output (synch.) of serial interface</td> </tr> <tr> <td>P3.2 / $\overline{INT0}$</td> <td>External Interrupt 0 input / Timer 0 gate control input</td> </tr> <tr> <td>P3.3 / $\overline{INT1}$</td> <td>External Interrupt 1 input / Timer 1 gate control input</td> </tr> <tr> <td>P3.4 / T0</td> <td>Timer 0 counter input</td> </tr> <tr> <td>P3.5 / T1</td> <td>Timer 1 counter input</td> </tr> <tr> <td>P3.6 / \overline{WR}</td> <td>\overline{WR} control output; latches the data byte from Port 0 into the external data memory</td> </tr> <tr> <td>P3.7 / \overline{RD}</td> <td>\overline{RD} control output; enables the external data memory to Port 0</td> </tr> </table>	P3.0 / RxD	Receiver data input (asynch.) or data input/output (synch.) of serial interface	P3.1 / TxD	Transmitter data output (asynch.) or clock output (synch.) of serial interface	P3.2 / $\overline{INT0}$	External Interrupt 0 input / Timer 0 gate control input	P3.3 / $\overline{INT1}$	External Interrupt 1 input / Timer 1 gate control input	P3.4 / T0	Timer 0 counter input	P3.5 / T1	Timer 1 counter input	P3.6 / \overline{WR}	\overline{WR} control output; latches the data byte from Port 0 into the external data memory	P3.7 / \overline{RD}	\overline{RD} control output; enables the external data memory to Port 0
P3.0 / RxD	Receiver data input (asynch.) or data input/output (synch.) of serial interface																				
P3.1 / TxD	Transmitter data output (asynch.) or clock output (synch.) of serial interface																				
P3.2 / $\overline{INT0}$	External Interrupt 0 input / Timer 0 gate control input																				
P3.3 / $\overline{INT1}$	External Interrupt 1 input / Timer 1 gate control input																				
P3.4 / T0	Timer 0 counter input																				
P3.5 / T1	Timer 1 counter input																				
P3.6 / \overline{WR}	\overline{WR} control output; latches the data byte from Port 0 into the external data memory																				
P3.7 / \overline{RD}	\overline{RD} control output; enables the external data memory to Port 0																				
RESET	9	10	4	I	<p>RESET</p> <p>A high level on this pin for the duration of two machine cycles while the oscillator is running resets the device. An internal diffused resistor to V_{SS} permits power-on reset using only an external capacitor to V_{DD}.</p>																

*) I = Input
 O = Output

Table 1
Pin Definitions and Functions (cont'd)

Symbol	Pin Number			I/O)	Function
	P- DIP -40	P-LCC- 44	P-MQFP- 44		
XTAL2	18	20	14	O	XTAL2 Output of the inverting oscillator amplifier.
XTAL1	19	21	15	I	XTAL1 Input to the inverting oscillator amplifier and input to the internal clock generator circuits. To drive the device from an external clock source, XTAL1 should be driven, while XTAL2 is left unconnected. There are no requirements on the duty cycle of the external clock signal, since the input to the internal clocking circuitry is divided down by a divide-by-two flip-flop. Minimum and maximum high and low times as well as rise/fall times specified in the AC characteristics must be observed.
P2.0- P2.7	21-28	24-31	18-25	I/O	Port 2 Port 2 is an 8-bit quasi-bidirectional I/O port with internal pull-up arrangement. Port 2 pins that have "1s" written to them are pulled high by the internal pull-up transistors, and in that state can be used as inputs. As inputs, Port 2 pins being externally pulled low will source current (I_{IL} , in the DC characteristics) because of the internal pullup transistors. Port 2 emits the high-order address byte during fetches from external program memory and during accesses to external data memory that use 16-bit addresses (MOVX @DPTR). In this application it uses strong internal pullup transistors when issuing "1"s. During accesses to external data memory that use 8-bit addresses (MOVX @Ri), Port 2 issues the contents of the P2 Special Function Register and uses only the internal pull-up transistors.
PSEN	29	32	26	O	Program Store Enable This is a control signal that enables output of the external program memory to the bus during external fetch operations. It is activated every three oscillator periods except during external data memory accesses. It remains high during internal program execution. This pin should not be driven during reset operation.

*) I = Input
O = Output

Table 1
Pin Definitions and Functions (cont'd)

Symbol	Pin Number			I/O)	Function
	P-DIP -40	P-LCC- 44	P-MQFP- 44		
ALE	30	33	27	O	Address Latch Enable This output is used for latching the low-byte of the address into external memory during normal operation. It is activated every six oscillator periods except during an external data memory access. When instructions are executed from internal program memory ($\overline{EA} = 1$) the ALE generation can be disabled by bit EALE in SFR SYSCON. This pin should not be driven during reset operation.
\overline{EA}	31	35	29	I	External Access Enable When held at high level, instructions are fetched from the internal program memory when the PC is less than 4000 _H . When held at low level, the C513AO fetches all instructions from external program memory. This pin should not be driven during reset operation. Note: For the C513AO-L this pin must be tied low.
P0.0- P0.7	32-39	43-36	37-30	I/O	Port 0 Port 0 is an 8-bit open-drain bidirectional I/O port. Port 0 pins that have "1s" written to them float, and in that state can be used as high-impedance inputs. Port 0 is also the multiplexed low-order address and data bus during accesses to external program or data memory. In this application, it uses strong internal pull-up transistors when issuing 1s. External pull-up resistors are required during program verification.
V_{SS}	20	22, 1	16, 39	–	Ground (0 V)
V_{DD}	40	44, 23	38, 17	–	Power Supply (+ 5 V)
N.C.	–	12, 34	6, 28	–	No Connection. These pins should not be connected.

*) I = Input
 O = Output

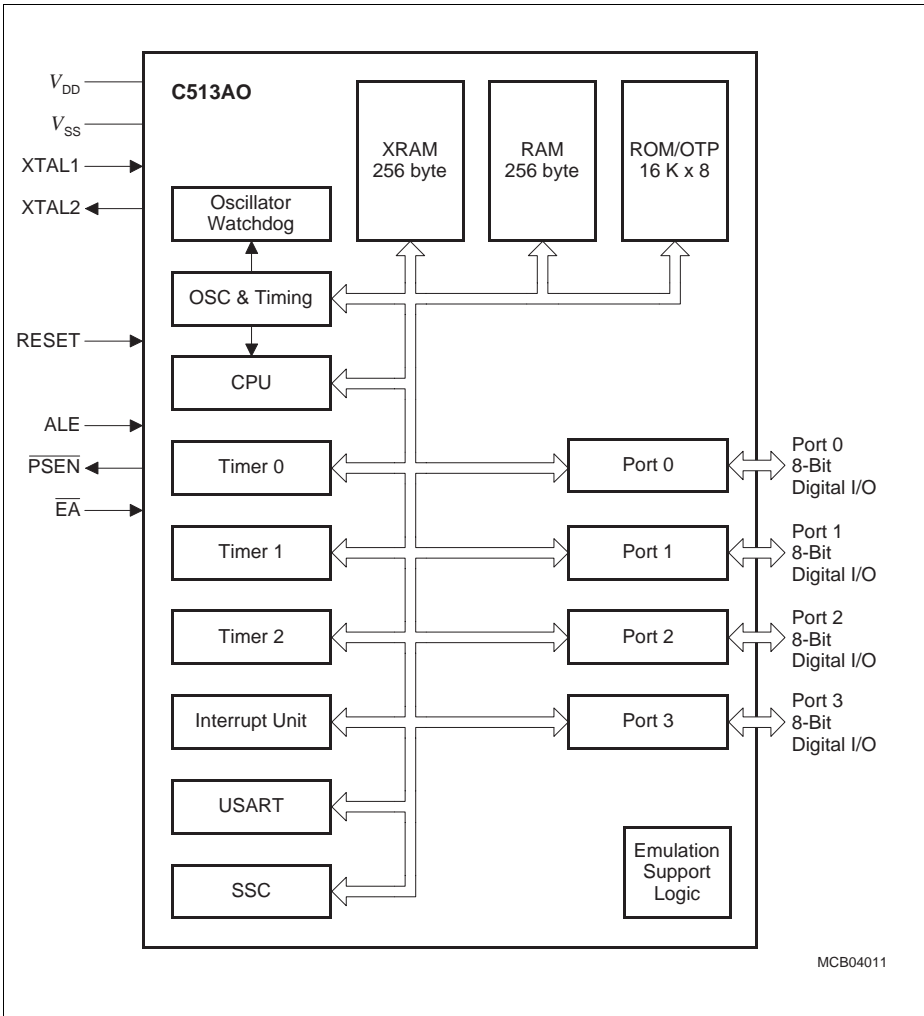

Figure 6
Block Diagram of the C513AO

CPU

The C513AO is efficient both as a controller and as an arithmetic processor. It has extensive facilities for binary and BCD arithmetic and excels in its bit-handling capabilities. Efficient use of program memory results from an instruction set consisting of 44% one-byte, 41% two-byte, and 15% three-byte instructions. With a 16-MHz crystal, 58% of the instructions execute in 750 ns.

Special Function Register PSW (Address D0_H)
Reset Value: 00_H

Bit No.	MSB							LSB	
	D7 _H	D6 _H	D5 _H	D4 _H	D3 _H	D2 _H	D1 _H	D0 _H	
D0 _H	CY	AC	F0	RS1	RS0	OV	F1	P	PSW

Bit	Function															
CY	Carry Flag Used by arithmetic instruction.															
AC	Auxiliary Carry Flag Used by instructions which execute BCD operations.															
F0	General Purpose Flag 0															
RS1 RS0	Register bank Select control bits These bits are used to select one of the four register banks.															
	<table border="1" style="width: 100%; border-collapse: collapse;"> <thead> <tr> <th style="width: 15%;">RS1</th> <th style="width: 15%;">RS0</th> <th style="width: 70%;">Function</th> </tr> </thead> <tbody> <tr> <td>0</td> <td>0</td> <td>Bank 0 selected, data address 00_H-07_H</td> </tr> <tr> <td>0</td> <td>1</td> <td>Bank 1 selected, data address 08_H-0F_H</td> </tr> <tr> <td>1</td> <td>0</td> <td>Bank 2 selected, data address 10_H-17_H</td> </tr> <tr> <td>1</td> <td>1</td> <td>Bank 3 selected, data address 18_H-1F_H</td> </tr> </tbody> </table>	RS1	RS0	Function	0	0	Bank 0 selected, data address 00 _H -07 _H	0	1	Bank 1 selected, data address 08 _H -0F _H	1	0	Bank 2 selected, data address 10 _H -17 _H	1	1	Bank 3 selected, data address 18 _H -1F _H
RS1	RS0	Function														
0	0	Bank 0 selected, data address 00 _H -07 _H														
0	1	Bank 1 selected, data address 08 _H -0F _H														
1	0	Bank 2 selected, data address 10 _H -17 _H														
1	1	Bank 3 selected, data address 18 _H -1F _H														
OV	Overflow Flag Used by arithmetic instruction.															
F1	General Purpose Flag 1															
P	Parity Flag Set/cleared by hardware after each instruction to indicate an odd/even number of "one" bits in the accumulator, i.e. even parity.															

Memory Organization

The C513AO CPU manipulates operands in the following five address spaces:

- Up to 64 Kbytes of program memory (up to 16 KB on-chip program memory for the C513AO-2R/2E)
- Up to 64 Kbytes of external data memory
- 256 bytes of internal data memory
- 256 bytes of internal XRAM data memory
- One 128-byte special function register area

Figure 7 illustrates the memory address spaces of the C513AO.

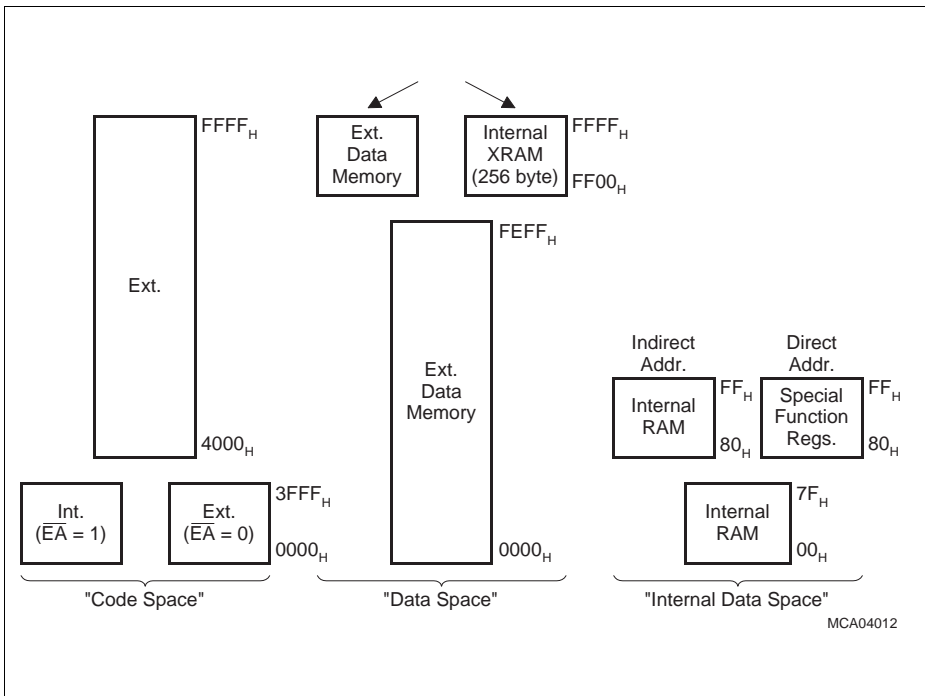

Figure 7
C513AO Memory Map

Reset and System Clock

The reset input is an active high input. An internal Schmitt-trigger is used at the input for noise rejection. Since the reset is synchronized internally, the RESET pin must be held high for at least two machine cycles (24 oscillator periods) while the oscillator is running. With the oscillator running, the internal reset is executed during the second machine cycle and is repeated every cycle until RESET goes low again. **Figure 8** shows the possible reset circuitries.

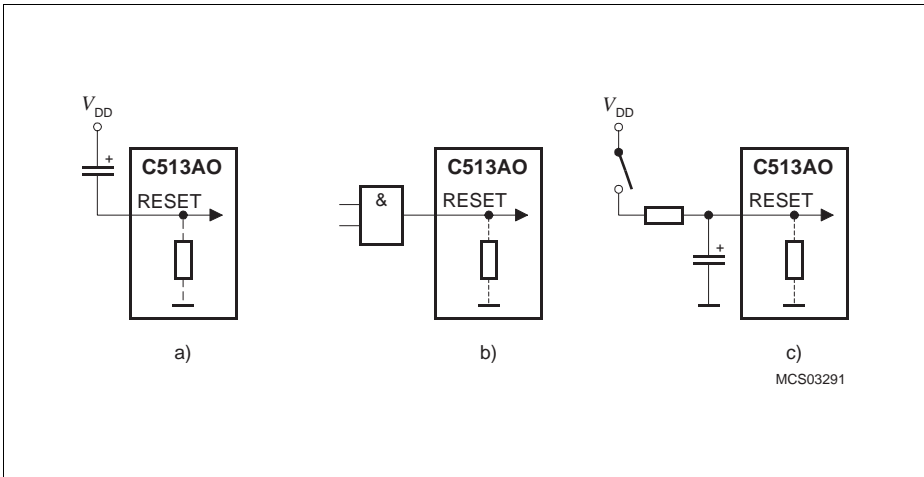

Figure 8
Reset Circuitries

Figure 9 shows the recommended oscillator circuitries for crystal and external clock operation.

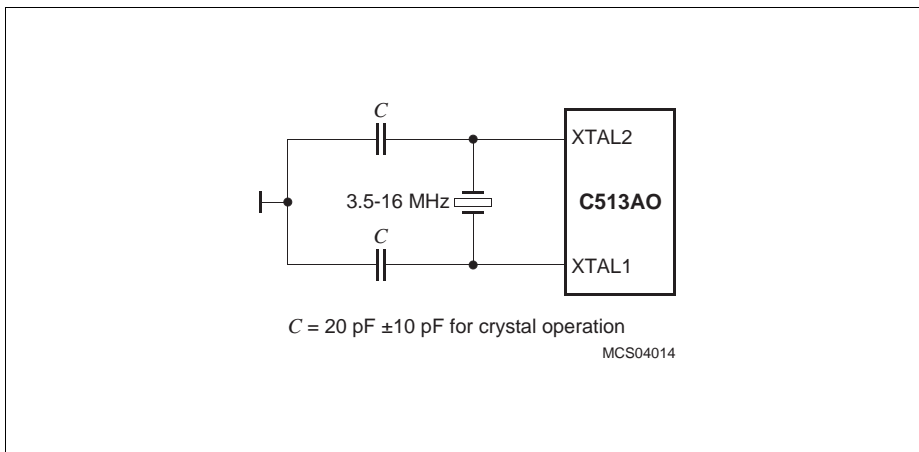

Figure 9
Recommended Oscillator Circuitry

In this application, the on-chip oscillator is used as a crystal-controlled, positive-reactance oscillator (a more detailed schematic is given in **Figure 10**). It is operated in its fundamental response mode as an inductive reactor in parallel resonance with a capacitor external to the chip. The crystal specifications and capacitances are non-critical. In this circuit, 20 pF can be used as single capacitance at any frequency together with a good quality crystal. A ceramic resonator can be used in place of the crystal in cost-critical applications. If a ceramic resonator is used, the two capacitors normally will have different values, dependent on the oscillator frequency. We recommend consulting the manufacturer of the ceramic resonator for value specifications of these capacitors.

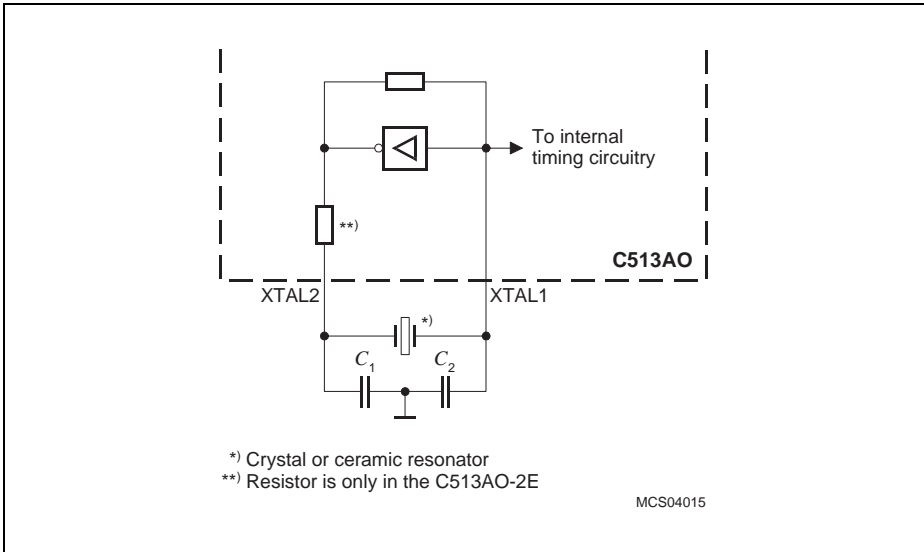

Figure 10
On-Chip Oscillator Circuitry

To drive the C513AO with an external clock source, the external clock signal must be applied to XTAL1, as shown in **Figure 11**. XTAL2 must be left unconnected. A pull-up resistor is suggested to increase the noise margin, but is optional if V_{OH} of the driving gate corresponds to the V_{IH2} specification of XTAL1.

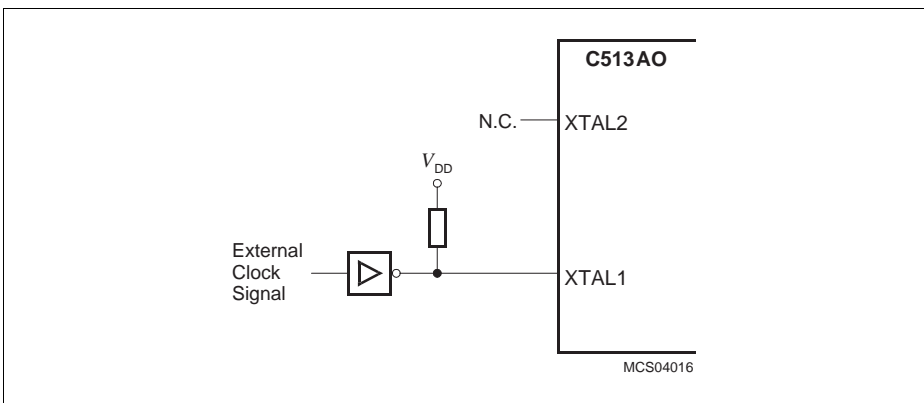

Figure 11
External Clock Source

Enhanced Hooks Emulation Concept

The Enhanced Hooks Emulation Concept of the C500 microcontroller family is a new, innovative way to control the execution of C500 MCUs and to gain extensive information on the internal operation of the controllers. Emulation of on-chip ROM based programs is possible, too.

Each production chip has built-in logic for the support of the Enhanced Hooks Emulation Concept. Therefore, no costly bond-out chips are necessary for emulation. This also ensure that emulation and production chips are identical.

The Enhanced Hooks Technology™¹⁾, which requires embedded logic in the C500 allows the C500 together with an EH-IC to function similar to a bond-out chip. This simplifies the design and reduces costs of an ICE-system. ICE-systems using an EH-IC and a compatible C500 are able to emulate all operating modes of the different versions of the C500 microcontrollers. This includes emulation of ROM, ROM with code rollover and ROMless modes of operation. It is also able to operate in single step mode and to read the SFRs after a break.

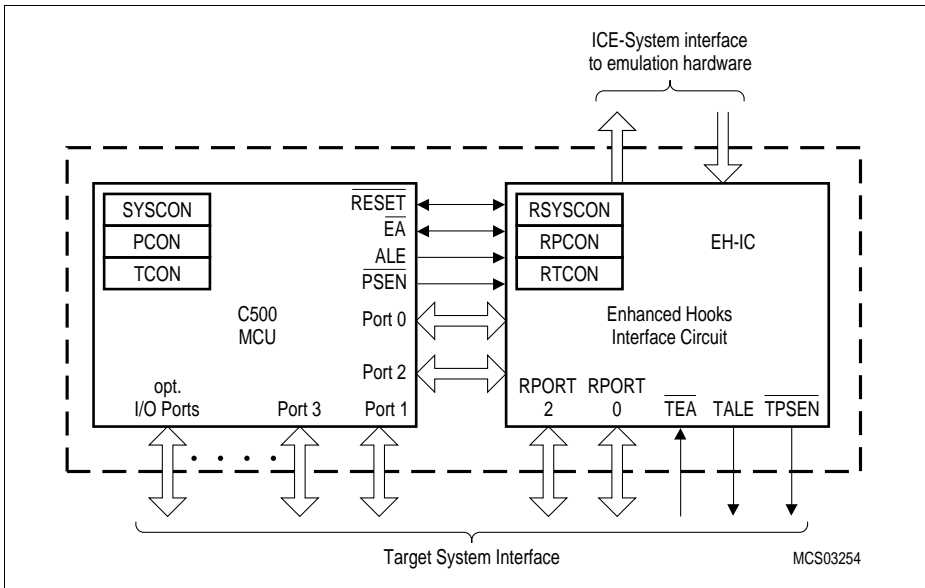

Figure 12
Basic C500 MCU Enhanced Hooks Concept Configuration

Port 0, port 2 and some of the control lines of the C500 based MCU are used by Enhanced Hooks Emulation Concept to control the operation of the device during emulation and to transfer informations about the program execution and data transfer between the external emulation hardware (ICE-system) and the C500 MCU.

1 "Enhanced Hooks Technology" is a trademark and patent of Metalink Corporation licensed to Infineon Technologies.

Special Function Registers

The registers reside in the special function register area, with the exception of the Program Counter and the four General Purpose Register banks. The special function register area consists of two portions: the *standard* special function register area and the *mapped* special function register area. Four special function registers of the C513AO (PCON1, VR0, VR1 & VR2) are located in the mapped special function register area. For accessing the mapped special function register area, bit RMAP in special function register SYSCON must be set. All other special function registers of the C513AO are located in the standard special function register area.

Special Function Register SYSCON (Address B1_H)

Reset Value: XX10XX0_B

Bit No.	MSB							LSB	
	7	6	5	4	3	2	1		
B1 _H	-	-	EALE	RMAP	-	-	-	XMAP	SYSCON

The functions of the shaded bits are not described in this section.

Bit	Function
RMAP	<p>Special function Register MAP bit</p> <p>RMAP = 0: The access to the non-mapped (standard) special function register area is enabled.</p> <p>RMAP = 1: The access to the mapped special function register area is enabled.</p>
-	Reserved bits for future use. Read by CPU returns undefined values.

If bit RMAP is set, mapped special function registers can be accessed. This bit is not cleared by hardware automatically.

The forty Special Function Registers (SFRs) in the standard and mapped SFR area include pointers and registers that provide an interface between the CPU and the other on-chip peripherals. The SFRs of the C513AO are listed in **Table 2** and **Table 3**. In **Table 2**, they are organized in groups which refer to the functional blocks of the C513AO. **Table 3** illustrates the contents of the SFRs in numeric order of their addresses.

Table 2
Special Function Registers - Functional Blocks

Block	Symbol	Name	Address	Contents after Reset
CPU	ACC	Accumulator	E0_H ¹⁾	00 _H
	B	B-Register	F0_H ¹⁾	00 _H
	DPH	Data Pointer, High Byte	83 _H	00 _H
	DPL	Data Pointer, Low Byte	82 _H	00 _H
	PSW	Program Status Word Register	D0_H ¹⁾	00 _H
	SP	Stack Pointer	81 _H	07 _H
	SYSCON ²⁾	System Control Register	B1 _H	XX10XXX0 _B ³⁾
	VR0 ^{4) 5)}	Version Register 0	FC _H	C5 _H
VR1 ^{4) 5)}	Version Register 1 ⁶⁾	FD _H	–	
VR2 ^{4) 5)}	Version Register 2 ⁷⁾	FE _H	–	
Interrupt System	IE	Interrupt Enable Register	A8_H ¹⁾	00 _H
	IP	Interrupt Priority Register	B8_H ¹⁾	X0000000 _B ³⁾
Ports	P0	Port 0	80_H ¹⁾	FF _H
	P1	Port 1	90_H ¹⁾	FF _H
	P2	Port 2	A0_H ¹⁾	FF _H
	P3	Port 3	B0_H ¹⁾	FF _H
Serial Channel (USART)	PCON ²⁾	Power Control Register	87 _H	000X0000 _B
	SBUF	Serial Channel Buffer Register	99 _H	XX _H ³⁾
	SCON	Serial Channel Control Register	98_H ¹⁾	00 _H
SSC Interface	SSCCON	SSC Control Register	E8_H ¹⁾	07 _H
	STB	SSC Transmit Register	E9 _H	XX _H ³⁾
	SRB	SSC Receive Register	EA _H	XX _H ³⁾
	SCF	SSC Flag Register	F8_H ¹⁾	XXXXXX00 _B ³⁾
	SCIEN	SSC Interrupt Enable Register	F9 _H	XXXXXX00 _B ³⁾
	SSCMOD ⁸⁾	SSC Mode Test Register	EB _H	00 _H
Timer 0/ Timer 1	TCON	Timer 0/1 Control Register	88_H ¹⁾	00 _H
	TH0	Timer 0, High Byte	8C _H	00 _H
	TH1	Timer 1, High Byte	8D _H	00 _H
	TL0	Timer 0, Low Byte	8A _H	00 _H
	TL1	Timer 1, Low Byte	8B _H	00 _H
	TMOD	Timer Mode Register	89 _H	00 _H

1) Bit-addressable special function registers

2) This special function register is listed repeatedly since some bits of it also belong to other functional blocks.

3) "X" means that the value is undefined and the location is reserved

4) This SFR is a mapped SFR area. For accessing this SFR, bit RMAP in SFR SYSCON must be set.

5) This SFR is read-only.

6) C513AO-L/2R: 13_H

C513AO-2E: 83_H

7) This SFR varies with the step of the microcontroller: for example, 01_H for the first step

8) This register is only used for test purposes and must not be written during normal operation. Unpredictable results may occur upon a write operation.

Table 2
Special Function Registers - Functional Blocks (cont'd)

Block	Symbol	Name	Address	Contents after Reset
Timer 2	T2CON	Timer 2 Control Register	C8_H ¹⁾	00 _H
	T2MOD	Timer 2 Mode Register	C9 _H	XXXXXXXX0 _B ³⁾
	RC2H	Timer 2 Reload/Capture Register, High Byte	CB _H	00 _H
	RC2L	Timer 2 Reload/Capture Register, Low Byte	CA _H	00 _H
	TH2	Timer 2 High Byte	CD _H	00 _H
	TL2	Timer 2 Low Byte	CC _H	00 _H
	Watchdog	WDCON	Watchdog Timer Control Register	C0_H ¹⁾
WDTREL		Watchdog Timer Reload Register	86 _H	00 _H
Power Save Mode	PCON ²⁾	Power Control Register	87 _H	000X0000 _B ³⁾
	PCON1 ⁴⁾	Power Control Register 1	88 _H	0XXXXXXXX _B ³⁾

1) Bit-addressable special function registers

2) This special function register is listed repeatedly since some bits of it also belong to other functional blocks.

3) "X" means that the value is undefined and the location is reserved

4) This SFR is a mapped SFR area. For accessing this SFR, bit RMAP in SFR SYSCON must be set.

5) This SFR is read-only.

6) C513AO-L/2R: 13_H

C513AO-2E: 83_H

7) This SFR varies with the step of the microcontroller: for example, 01_H for the first step

8) This register is only used for test purposes and must not be written during normal operation. Unpredictable results may occur upon a write operation.

Table 3
Contents of the SFRs, SFRs in Numeric Order of their Addresses

Addr.	Register	Content after Reset ¹⁾	Bit 7	Bit 6	Bit 5	Bit 4	Bit 3	Bit 2	Bit 1	Bit 0
80 _H ²⁾	P0	FF _H	.7	.6	.5	.4	.3	.2	.1	.0
81 _H	SP	07 _H	.7	.6	.5	.4	.3	.2	.1	.0
82 _H	DPL	00 _H	.7	.6	.5	.4	.3	.2	.1	.0
83 _H	DPH	00 _H	.7	.6	.5	.4	.3	.2	.1	.0
86 _H	WDTREL	00 _H	WDT PSEL	.6	.5	.4	.3	.2	.1	.0
87 _H	PCON	0XX0-0000 _B	SMOD	–	–	SD	GF1	GF0	PDE	IDLE
88 _H ^{2) 3)}	TCON	00 _H	TF1	TR1	TF0	TR0	IE1	IT1	IE0	IT0
88 _H ³⁾	PCON1	0XX0-XXXX _B	EWPD	–	–	–	–	–	–	–
89 _H	TMOD	00 _H	GATE	C/T	M1	M0	GATE	C/T	M1	M0
8A _H	TL0	00 _H	.7	.6	.5	.4	.3	.2	.1	.0
8B _H	TL1	00 _H	.7	.6	.5	.4	.3	.2	.1	.0
8C _H	TH0	00 _H	.7	.6	.5	.4	.3	.2	.1	.0
8D _H	TH1	00 _H	.7	.6	.5	.4	.3	.2	.1	.0
90 _H ²⁾	P1	FF _H	–	–	.SLS	STO	SRI	SCLK	T2EX	T2
98 _H ²⁾	SCON	00 _H	SM0	SM1	SM2	REN	TB8	RB8	TI	RI
99 _H	SBUF	XX _H	.7	.6	.5	.4	.3	.2	.1	.0
A0 _H ²⁾	P2	FF _H	.7	.6	.5	.4	.3	.2	.1	.0
A8 _H ²⁾	IE	00 _H	EA	ESSC	ET2	ES	ET1	EX1	ET0	EX0
B0 _H ²⁾	P3	FF _H	R \overline{D}	W \overline{R}	T1	T0	I $\overline{N}T1$	I $\overline{N}T0$	TxD	RxD
B1 _H	SYSCON	XX10-XXX0 _B	–	–	EALE	RMAP	–	–	–	XMAP
B8 _H ²⁾	IP	X000-0000 _B	–	PSSC	PT2	PS	PT1	PX1	PT0	PX0
C0 _H ²⁾	WDCON	XXXX-0000 _B	–	–	–	–	OWDS	WDS	WDT	SWDT

- 1) "X" means that the value is undefined and the location is reserved.
- 2) Bit-addressable special function registers.
- 3) SFR is located in the mapped SFR area. For accessing this SFR, bit RMAP in SFR SYSCON must be set.
- 4) These are read-only registers.
- 5) The content of this SFR varies with the actual step of the C513AO: for example, 01_H for the first step).
- 6) This register is only used for test purposes and must not be written during normal operation. Unpredictable results may occur upon a write operation.

Table 3
Contents of the SFRs, SFRs in Numeric Order of their Addresses (cont'd)

Addr.	Register	Content after Reset ¹⁾	Bit 7	Bit 6	Bit 5	Bit 4	Bit 3	Bit 2	Bit 1	Bit 0
C8 _H ²⁾	T2CON	00 _H	TF2	EXF2	RCLK	TCLK	EXEN2	TR2	C/ $\overline{\text{T2}}$	CP/RL2
C9 _H	T2MOD	XXXX-XXX0 _B	–	–	–	–	–	–	–	DCEN
CA _H	RC2L	00 _H	.7	.6	.5	.4	.3	.2	.1	.0
CB _H	RC2H	00 _H	.7	.6	.5	.4	.3	.2	.1	.0
CC _H	TL2	00 _H	.7	.6	.5	.4	.3	.2	.1	.0
CD _H	TH2	00 _H	.7	.6	.5	.4	.3	.2	.1	.0
D0 _H ²⁾	PSW	00 _H	CY	AC	F0	RS1	RS0	OV	F1	P
E0 _H ²⁾	ACC	00 _H	.7	.6	.5	.4	.3	.2	.1	.0
E8 _H ²⁾	SSCCON	07 _H	SCEN	TEN	MSTR	CPOL	CPHA	BRS2	BRS1	BRS0
E9 _H	STB	XX _H	.7	.6	.5	.4	.3	.2	.1	.0
EA _H	SRB	XX _H	.7	.6	.5	.4	.3	.2	.1	.0
EB _H	SSCMOD	00 _H ⁶⁾	LOOPB	TRIO	0	0	0	0	0	LSBSM
F0 _H ²⁾	B	00 _H	.7	.6	.5	.4	.3	.2	.1	.0
F8 _H ²⁾	SCF	XXXX-XX00 _B	–	–	–	–	–	–	WCOL	TC
F9 _H	SCIEN	XXXX-XX00 _B	–	–	–	–	–	–	WCEN	TCEN
FC _H ^{3) 4)}	VR0	C5 _H	.7	.6	.5	.4	.3	.2	.1	.0
FD _H ^{3) 4)}	VR1	– ⁷⁾	.7	.6	.5	.4	.3	.2	.1	.0
FE _H ^{3) 4)}	VR2	– ⁵⁾	.7	.6	.5	.4	.3	.2	.1	.0

1) "X" means that the value is undefined and the location is reserved

2) Bit-addressable special function registers

3) SFR is located in the mapped SFR area. For accessing this SFR, bit RMAP in SFR SYSCON must be set.

4) These SFRs are read-only registers.

5) The content of this SFR varies with the actual step of the C513AO: for example, 01_H for the first step)

6) This register is only used for test purposes and must not be written during normal operation. Unpredictable results may occur upon a write operation.

7) C513AO-L/2R: 13_H
 C513AO-2E: 83_H

Parallel I/O Port

The C513AO has four 8-bit I/O ports. Port 0 is an open-drain bidirectional I/O port, while Ports 1, 2, and 3 are quasi-bidirectional I/O ports with internal pull-up resistors. Thus, when configured as inputs, Ports 1 to 3 will be pulled high and will source current when externally pulled low. Port 0 will float when configured as input.

The output drivers of Port 0 and Port 2 and the input buffers of Port 0 are also used for accessing external memory. In this application, Port 0 outputs the low byte of the external memory address, time multiplexed with the byte being written or read. Port 2 outputs the high byte of the external memory address when the address is 16 bits wide. Otherwise, the Port 2 pins continue to emit the P2 SFR contents. In this case, Port 0 is not an open-drain port, but uses a strong internal pull-up Field Effect Transistors (FETs).

Port 1 pins used for Synchronous Serial Channel (SSC) outputs are true push-pull outputs. When used as SSC inputs, they float (no pull-up).

Timer/Counter 0 and 1

Timer/Counter 0 and 1 can be used in four operating modes as listed in **Table 4**:

Table 4
Timer/Counter 0 and 1 Operating Modes

Mode	Description	TMOD		Input Clock	
		M1	M0	Internal	External (max.)
0	8-bit timer/counter with a divide-by-32 prescaler	0	0	$f_{osc}/(12 \times 32)$	$f_{osc}/(24 \times 32)$
1	16-bit timer/counter	1	1	$f_{osc}/12$	$f_{osc}/24$
2	8-bit timer/counter with 8-bit autoreload	1	0		
3	Timer/counter 0 used as one 8-bit timer/counter and one 8-bit timer Timer 1 stops	1	1		

In the “timer” function ($C/\bar{T} = '0'$) the register is incremented every machine cycle. Since a machine cycle consists of twelve oscillator periods, the count rate is 1/12th of the oscillator frequency.

In “counter” function, the register is incremented in response to a 1-to-0 transition (falling edge) at its corresponding external input pin, T0 or T1 (alternate functions of P3.4 and P3.5, respectively). Since it takes two machine cycles to detect a falling edge; therefore, the maximum count rate is 1/24th of the oscillator frequency. External inputs $\overline{INT0}$ and $\overline{INT1}$ (P3.2, P3.3) can be programmed to function as a gate to facilitate pulse width measurements. **Figure 13** illustrates the input clock logic.

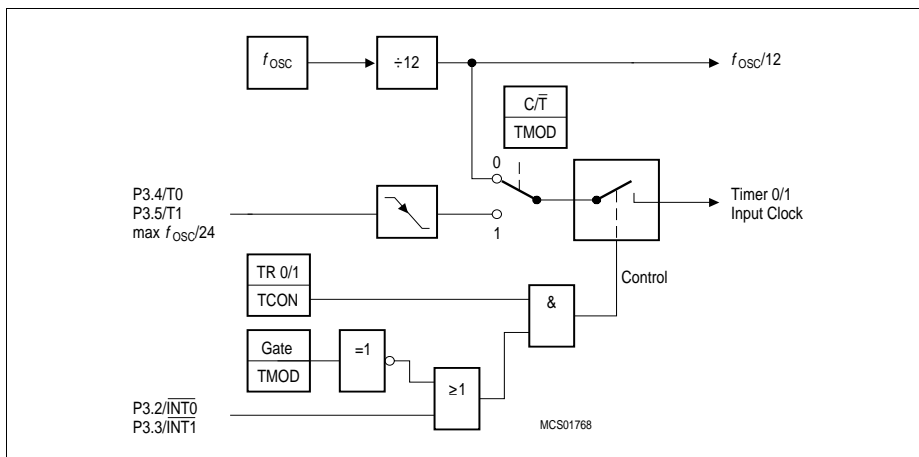

Figure 13
Timer/Counter 0 and 1 Input Clock Logic

Timer/Counter 2 with Compare/Capture/Reload

Timer 2 is a 16-bit timer/counter with an up/down count feature. It has three operating modes:

- 16-bit auto-reload mode (up or down counting)
- 16-bit capture mode
- Baudrate generator

Table 5
Timer / Counter 2 Operating Modes

Mode	T2CON			T2MOD	T2CON	P1.1/ T2EX	Remarks	Input Clock	
	RCLK or TCLK	CP/ RL2	TR2	DCEN	EXEN2			Internal	External (P1.0/ T2)
16-bit Auto- reload	0	0	1	0	0	X	reload upon overflow	$f_{osc}/12$	max $f_{osc}/24$
	0	0	1	0	1	↓	reload trigger (falling edge)		
	0	0	1	1	X	0	down counting		
	0	0	1	1	X	1	up counting		
16-bit Capture	0	1	1	X	0	X	16-bit Timer/ Counter (only up-counting)	$f_{osc}/12$	max $f_{osc}/24$
	0	1	1	X	1	↓	capture TH2, TL2 → RC2H, RC2L		
Baudrate Generator	1	X	1	X	0	X	no overflow interrupt	$f_{osc}/12$	max $f_{osc}/24$
	1	X	1	X	1	↓	request (TF2) extra external interrupt ("Timer 2")		
off	X	X	0	X	X	X	Timer 2 stops	–	–

Note: ↓ denotes a falling edge

Serial Interface (USART)

The serial port is a full duplex port capable of simultaneous transmit and receive functions. It is also receive-buffered; it can commence reception of a second byte before a previously-received byte has been read from the receive register. The serial port can operate in 4 modes (one synchronous and three asynchronous) as illustrated in **Table 6**.

Table 6
USART Operating Modes

Mode	SCON		Description
	SM0	SM1	
0	0	0	Shift register mode Serial data enters and exits through RxD. TxD outputs the shift clock. 8-bit data are transmitted/received (LSB first) at a fixed baudrate of $1/12$ th of the oscillator frequency.
1	0	1	8-bit USART, variable baudrate 10 bits are transmitted (through TxD) or received (at RxD).
2	1	0	9-bit USART, fixed baudrate 11 bits are transmitted (through TxD) or received (at RxD).
3	1	1	9-bit USART, variable baudrate Similar to mode 2, except for the variable baudrate.

For clarification, some terms regarding the difference between “baudrate clock” and “baudrate” should be mentioned.

The serial interface requires a clock rate which is 16 times the baudrate for internal synchronization. Therefore, the baudrate generators must provide a “baudrate clock” to the serial interface which divides it by 16, thereby resulting in the actual “baudrate”.

The baudrates in Mode 1 and 3 are determined by the timer overflow rate. These baudrates can be determined by Timer 1 or by Timer 2 or both (one for transmit, the other for receive).

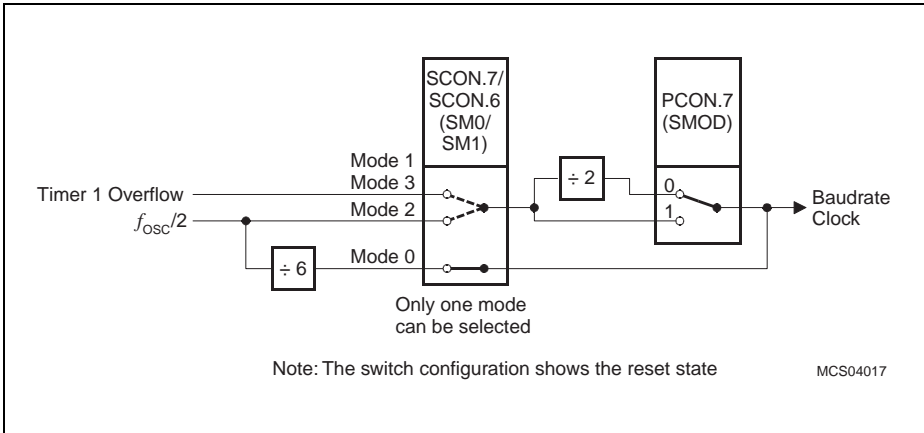

Figure 14
Block Diagram of Baudrate Generation for the Serial Interface

Table 7 lists the values/formulas for the baudrate calculation of the serial interface with its dependencies on the control bits SMOD (in SFR PCON), TCLK and RCLK (both in SFR T2CON).

Table 7
Serial Interface - Baudrate Dependencies

Serial Interface Operating Modes	Control Bits		Baudrate Calculation
	SMOD	TCLK/RCLK	
Mode 0 (Shift Register)	–	–	$f_{osc}/12$
Mode 1 (8-bit UART) Mode 3 (9-bit UART)	X	0	Determined by timer 1 overflow rate: $(2^{SMOD} \times \text{timer 1 overflow rate})/32$
	–	1	Determined by timer 2 overflow rate: Timer 2 overflow rate/16
Mode 2 (9-bit UART)	0	–	$f_{osc}/64$
	1	–	$f_{osc}/32$

SSC Interface

The Synchronous Serial Channel (SSC) interface is compatible to the popular SPI serial bus interface. It can be used for simple I/O expansion via shift registers, for connection with a variety of peripheral components (such as A/D converters, EEPROMs etc.), or interconnection of several microcontrollers in a master/slave structure. The SSC unit supports full-duplex or half-duplex operation and can run in Master Mode or Slave Mode.

Figure 15 shows the block diagram of the SSC.

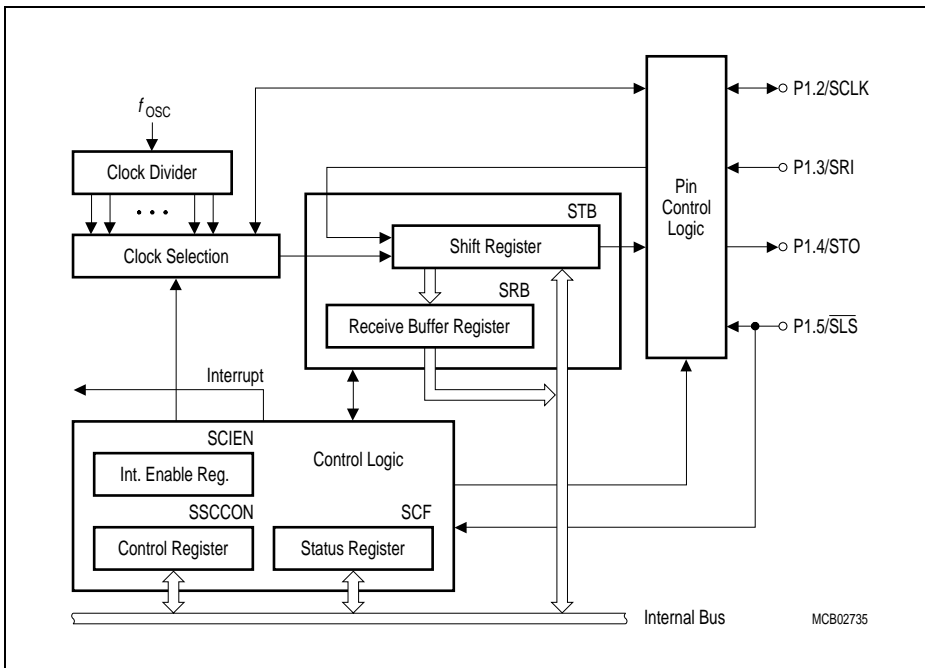

Figure 15
SSC Block Diagram

Interrupt System

The C513AO provides seven interrupt sources with two priority levels. Five of the interrupts can be generated by the on-chip peripherals (Timer 0, Timer 1, Timer 2, USART, and SSC) and three of the interrupts may be triggered externally (P1.1/T2EX, P3.2/INT0, P3.3/INT1). A non-maskable eighth interrupt is reserved for external wake-up from power-down mode.

Figure 16 gives a general overview of the interrupt sources and illustrates the request and the control flags. Table 8 lists the vector addresses of each interrupt source.

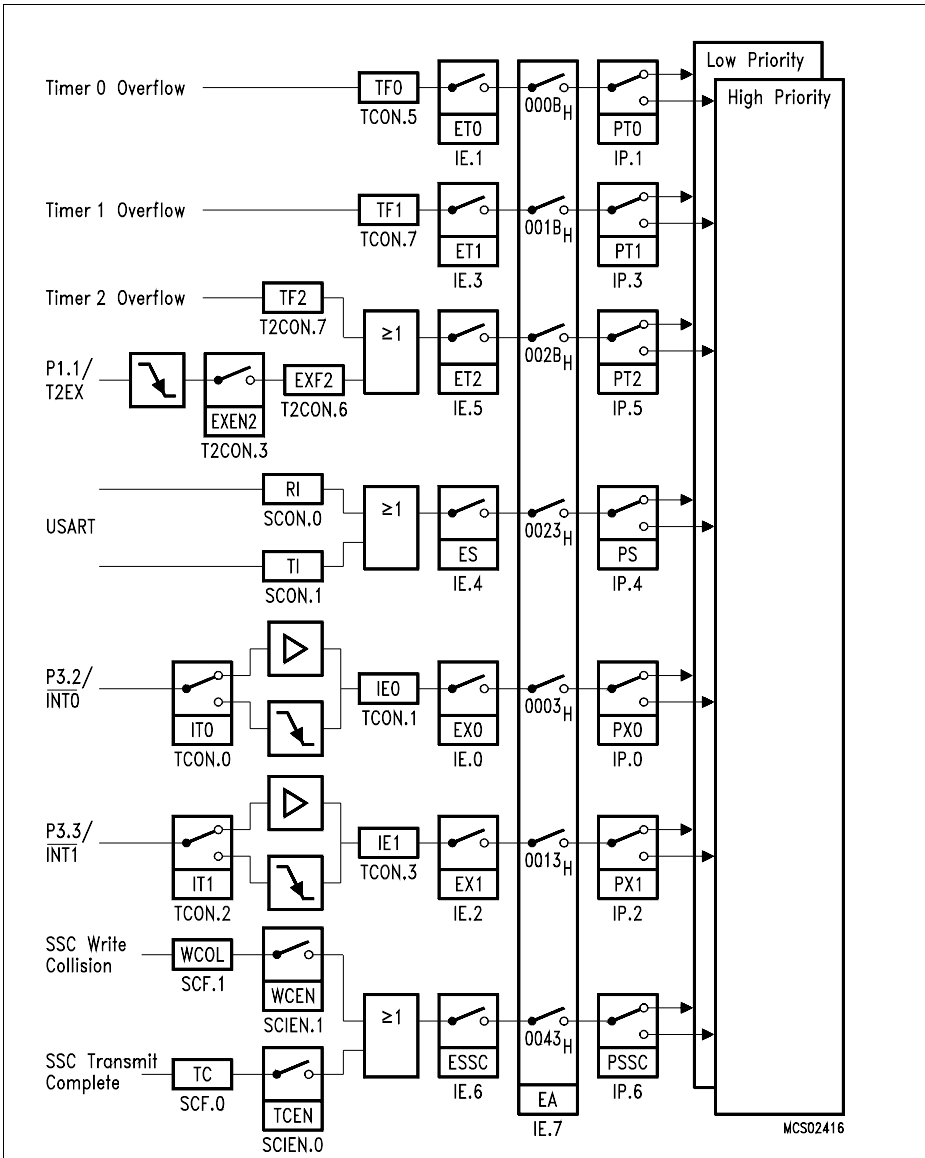



Figure 16
Interrupt Request Sources

Table 8
Interrupt Vector Addresses

Interrupt Source	Request Flags	Vector Address
External interrupt 0	IE0	0003 _H
Timer 0 interrupt	TF0	000B _H
External interrupt 1	IE1	0013 _H
Timer 1 interrupt	TF1	001B _H
USART serial port interrupt	RI + TI	0023 _H
Timer 2 interrupt	TF2 + EXF2	002B _H
Synchronous Serial Channel interrupt (SSC)	WCOL+TC	0043 _H
Wake-up from power-down mode	–	007B _H

If two interrupt requests of different priority levels are received simultaneously, the request of higher priority is serviced. If requests of the same priority are received simultaneously, an internal polling sequence determines which request is serviced. Thus, within each priority level there is a second priority structure determined by the polling sequence as shown in **Table 9**.

Table 9
Interrupt Source Structure

Interrupt Source	Priority
External Interrupt 0	High  Low
Synchronous Serial Channel	
Timer 0 Interrupt	
External Interrupt 1	
Timer 1 Interrupt	
Universal Serial Channel	
Timer 2 Interrupt	

A low-priority interrupt can be interrupted by a high-priority interrupt, but not by another low-priority interrupt. A high-priority interrupt cannot be interrupted by any other interrupt source.

Fail Save Mechanisms

The C513AO offers enhanced fail-safe mechanisms which allow automatic recovery from a software upset or a hardware failure:

- A programmable Watchdog Timer (WDT) has variable time-out period from 512 μ s up to approx. 1.1 sec. at 12 MHz
- An Oscillator Watchdog (OWD) monitors the on-chip oscillator and forces the microcontroller into reset state if the on-chip oscillator fails. It also provides the clock for a fast internal reset after power-on.

The Watchdog Timer in the C513AO is a 15-bit timer which is incremented by a count rate of either $f_{CYCLE}/2$ or $f_{CYCLE}/32$ ($f_{CYCLE} = f_{OSC}/12$). That is, the machine clock is divided by a fixed divide-by-two prescaler and an optional divide-by-16 prescaler arranged in series. For programming of the watchdog timer overflow rate, the upper 7 bit of the watchdog timer can be written. **Figure 17** shows the block diagram of the watchdog timer unit.

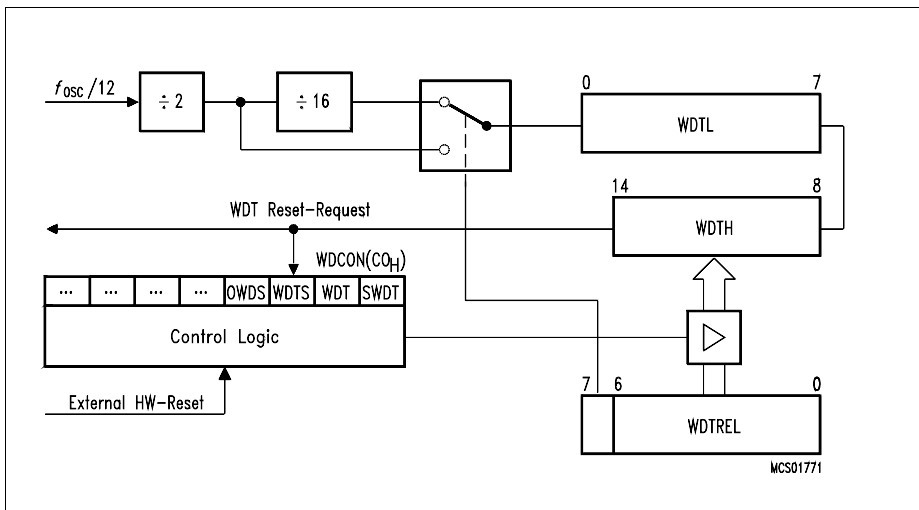

Figure 17
Block Diagram of the Watchdog Timer

The Watchdog Timer can be started by software (bit SWDT in SFR WDCON); but, it cannot be stopped during active mode of the device. If the software fails to clear the Watchdog Timer, an internal reset will be initiated. The reset cause can be examined by software (status flag WDTS in WDCON is set). A refresh of the Watchdog Timer is done by setting bits WDT (SFR WDCON) and SWDT consecutively. This double instruction sequence has been implemented to increase system security. During a refresh, the content of the SFR WDTREL is transferred to SFR WDTH, i.e. the upper 7-bit of the watchdog timer. It must be noted, however, that the watchdog timer is stopped during the idle mode and power down mode of the processor.

Oscillator Watchdog

The Oscillator Watchdog (OWD) unit is used for three functions:

- **Monitoring the on-chip oscillator's function**

The watchdog supervises the on-chip oscillator's frequency. If the frequency is lower than the frequency of the auxiliary RC oscillator in the watchdog unit, the internal clock is supplied by the RC oscillator and the device is brought into reset. If the failure condition disappears (that is, if the on-chip oscillator has a higher frequency than the RC oscillator), the device executes a final reset phase of typically 1 ms to allow the oscillator to stabilize. Then, the oscillator watchdog reset is released and the device resumes program execution.

- **Fast internal reset after power-on**

The oscillator watchdog unit provides a clock supply for reset before the on-chip oscillator has started. The oscillator watchdog unit reset works identically to the monitoring function.

- **Control of external wake-up from software power-down mode**

When power-down mode is terminated by a low level at the $\overline{\text{INT0}}$ pin, the oscillator watchdog unit ensures that the microcontroller resumes operation (execution of the power-down wake-up interrupt) with the nominal clock rate. In power-down mode, the RC oscillator and the on-chip oscillator are stopped. Both oscillators are started again when power-down mode is terminated. When the on-chip oscillator has a frequency higher than the RC oscillator, the microcontroller starts operation after a final delay of typ. 1 ms to allow the on-chip oscillator to stabilize.

Note: The Oscillator Watchdog unit is always enabled.

Figure 18 shows the block diagram of the Oscillator Watchdog unit.

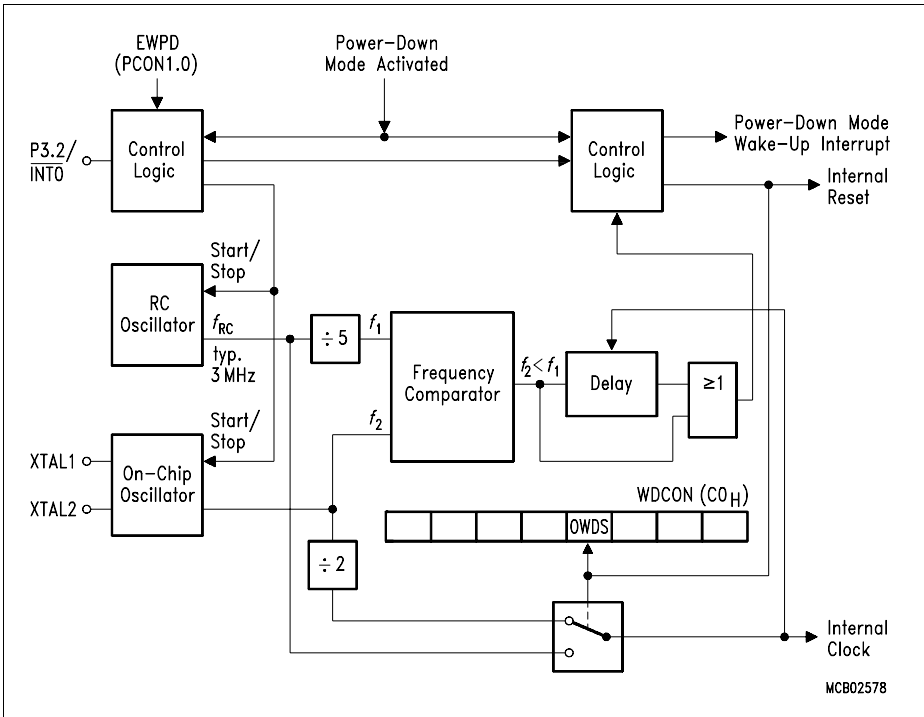

Figure 18
Block Diagram of the Oscillator Watchdog

Power Saving Modes

The C513AO provides three basic power-saving modes: Idle Mode, Slow-down Mode, and Power-down Mode.

- **Idle mode**

The CPU is gated off from the oscillator. All peripherals are still provided with the clock and are able to function. Idle mode is entered by software and can be left by an interrupt or reset.

- **Slow down mode**

The controller keeps up the full operating functionality, but its normal clock frequency is internally divided by 32. This slows down all parts of the controller, the CPU and all peripherals, to 1/32nd of their normal operating frequency and also reduces power consumption.

- **Power down mode**

The operation of the C513AO is completely stopped and the oscillator is turned off. This mode is used to save the contents of the internal RAM with a very low standby current. This power down mode is entered by software and can be left by reset or a short low pulse at pin P3.2/INT0.

In the power down mode of operation, V_{DD} can be reduced to minimize power consumption. It must be ensured, however, that V_{DD} is not reduced before the power down mode is invoked, and that V_{DD} is restored to its normal operating level, before the power down mode is terminated. **Table 10** gives a general overview of the entry and exit procedures of the power saving modes.

Table 10
Power Saving Modes Overview

Mode	Entering Example	Leaving by	Remarks
Idle mode	ORL PCON, #01 _H	Occurrence of an any enabled interrupt	CPU clock is stopped; CPU maintains their data; peripheral units are active (if enabled) and provided with clock
		Hardware reset	
Slow Down Mode	In normal mode: ORL PCON, #10 _H	ANL PCON, #0EF _H or Hardware reset	Internal clock rate is reduced to 1/32 of its nominal frequency
	With idle mode: ORL PCON, #11 _H	Occurrence of any enabled interrupt and the instruction ANL PCON, #0EF _H	CPU clock is stopped; CPU maintains their data; peripheral units are active (if enabled) and provided with 1/32 of its nominal frequency
		Hardware reset	
Power Down Mode	ORL PCON, #02 _H	Hardware reset	Oscillator is stopped; contents of on-chip RAM and SFRs are maintained;
		Short low pulse at pin P3.2/INT0	

Absolute Maximum Ratings

Parameter	Symbol	Limit Values		Unit	Notes
		min.	max.		
Storage temperature	T_{ST}	- 65	150	°C	-
Voltage on V_{DD} pins with respect to ground (V_{SS})	V_{DD}	- 0.5	6.5	V	-
Voltage on any pin with respect to ground (V_{SS})	V_{IN}	- 0.5	$V_{DD} + 0.5$	V	-
Input current on any pin during overload condition	-	- 10	10	mA	-
Absolute sum of all input currents during overload condition	-	-	100 mA	mA	-
Power dissipation	P_{DISS}	-	t.b.d.	W	-

Note: Stresses above those listed under “Absolute Maximum Ratings” may cause permanent damage of the device. This is a stress rating only and functional operation of the device at these or any other conditions above those indicated in the operational sections of this specification is not implied. Exposure to absolute maximum rating conditions for longer periods may affect device reliability. During absolute maximum rating overload conditions ($V_{IN} > V_{DD}$ or $V_{IN} < V_{SS}$) the voltage on V_{DD} pins with respect to ground (V_{SS}) must not exceed the values defined by the absolute maximum ratings.

Operating Conditions

Parameter	Symbol	Limit Values		Unit	Notes
		min.	max.		
Supply voltage	V_{DD}	4.25	5.5	V	-
Ground voltage	V_{SS}	0		V	-
Ambient temperature				°C	-
SAB-C513AO	T_A	0	70		
SAF-C513AO	T_A	- 40	85		
CPU clock	f_{CPU}	3.5	16	MHz	-

Parameter Interpretation

The parameters listed in the following partly represent the characteristics of the C513AO and partly its demands on the system. To aid in interpreting the parameters right, when evaluating them for a design, they are marked in column "Symbol":

CC (Controller Characteristics):

The logic of the C513AO will provide signals with the respective characteristics.

SR (System Requirement):

The external system must provide signals with the respective characteristics to the C513AO.

DC Characteristics

(Operating Conditions apply)

Parameter	Symbol	Limit Values		Unit	Test Condition
		min.	max.		
Input low voltage Pins except EA, RESET	V_{IL} SR	-0.5	$0.2 V_{DD} - 0.1$	V	-
EA pin	V_{IL1} SR	-0.5	$0.2 V_{DD} - 0.3$	V	-
RESET pin	V_{IL2} SR	-0.5	$0.2 V_{DD} + 0.1$	V	-
Input high voltage Pins except XTAL1, RESET	V_{IH} SR	$0.6 V_{DD}$	$V_{DD} + 0.5$	V	-
XTAL1 pin	V_{IH1} SR	$0.7 V_{DD}$	$V_{DD} + 0.5$	V	-
RESET pin	V_{IH2} SR	$0.6 V_{DD}$	$V_{DD} + 0.5$	V	-
Output low voltage Ports 1, 2, 3 (except P1.2, P1.4)	V_{OL} CC	-	0.45	V	$I_{OL} = 1.6 \text{ mA}^1$
Port 0, ALE, $\overline{\text{PSEN}}$	V_{OL1} CC	-	0.45	V	$I_{OL} = 3.2 \text{ mA}^1$
P1.2, P1.4 pull-up transistor resistance	R_{DSON} CC	-	120	Ω	$V_{OL} = 0.45 \text{ V}$
Output High Voltage Ports 1, 2, 3	V_{OH} CC	2.4	-	V	$I_{OH} = -80 \mu\text{A}$,
		$0.9 V_{DD}$	-	V	$I_{OH} = -10 \mu\text{A}$
Port 0 in external bus mode, ALE, $\overline{\text{PSEN}}$	V_{OH1} CC	2.4	-	V	$I_{OH} = -800 \mu\text{A}$,
		$0.9 V_{DD}$	-	V	$I_{OH} = -80 \mu\text{A}^2$
P1.2, P1.4 pull-up transistor resistance	R_{DSON} CC	-	120	Ω	$V_{OH} = 0.9 V_{DD}$
Logic 0 input current Ports 1, 2, 3	I_{IL} SR	-10	-70	μA	$V_{IN} = 0.45 \text{ V}$
Logical 0-to-1 transition current, Ports 1, 2, 3	I_{TL} SR	-65	-650	μA	$V_{IN} = 2 \text{ V}$
Input Leakage Current Port 0, EA P1.2, P1.3, P1.5 as SSC inputs	I_{LI} CC	-	± 1	μA	$0.45 < V_{IN} < V_{DD}$
Input high current to RESET for reset	I_{IH} CC	5	100	μA	$0.6 < V_{IN} < V_{DD}$

DC Characteristics (cont'd)
 (Operating Conditions apply)

Parameter	Symbol	Limit Values		Unit	Test Condition
		min.	max.		
Input low current to XTAL1	I_{IL2} CC	–	– 20	μA	$V_{IN} = 0.45$ V
Pin capacitance	C_{IO} CC	–	10	pF	$f_C = 1$ MHz, $T_A = 25$ °C
Overload current	I_{OV} SR	–	± 5	mA	⁸⁾ ⁹⁾

Notes see next page.

Power Supply Current

Parameter			Symbol	Limit Values		Unit	Test Condition
				typ. ¹⁰⁾	max.		
Active mode	C513AO-2E	12 MHz	I_{DD}	10.3	13.0	mA	4)
		16 MHz	I_{DD}	13.1	16.6	mA	
	C513AO-2R	12 MHz	I_{DD}	6.9	9.0	mA	4)
		16 MHz	I_{DD}	8.5	10.9	mA	
Idle mode	C513AO-2E	12 MHz	I_{DD}	5.7	7.2	mA	5)
		16 MHz	I_{DD}	6.8	8.7	mA	
	C513AO-2R	12 MHz	I_{DD}	4.1	5.5	mA	5)
		16 MHz	I_{DD}	4.8	6.0	mA	
Active mode with slow-down enabled	C513AO-2E	12 MHz	I_{DD}	4.5	5.7	mA	6)
		16 MHz	I_{DD}	5.1	6.5	mA	
	C513AO-2R	12 MHz	I_{DD}	3.3	4.1	mA	6)
		16 MHz	I_{DD}	3.6	4.5	mA	
Idle mode with slow-down enabled	C513AO-2E	12 MHz	I_{DD}	3.7	4.7	mA	7)
		16 MHz	I_{DD}	4.0	5.1	mA	
	C513AO-2R	12 MHz	I_{DD}	2.6	3.3	mA	7)
		16 MHz	I_{DD}	2.8	3.5	mA	
Power-down mode	C513AO-2E		I_{PD}	8.8	50	μA	$V_{DD} = 2 \dots 5.5$ V ³⁾
	C513AO-2R		I_{PD}	1.28	20	μA	$V_{DD} = 2 \dots 5.5$ V ³⁾

Notes:

- 1) Capacitive loading on ports 0 and 2 may cause spurious noise pulses to be superimposed on the V_{OL} of ALE and port 3. The noise is due to external bus capacitance discharging into the port 0 and port 2 pins when these pins make 1-to-0 transitions during bus operation. In the worst case (capacitive loading > 100 pF), the noise pulse on ALE line may exceed 0.8 V. In such cases it may be desirable to qualify ALE with a Schmitt-trigger, or use an address latch with a Schmitt-trigger strobe input.
- 2) Capacitive loading on ports 0 and 2 may cause the V_{OH} on ALE and PSEN to momentarily fall below the 0.9 V_{DD} specification when the address lines are stabilizing.
- 3) I_{PD} (power-down mode) is measured under following conditions:
 $EA = Port0 = V_{DD}$; $RESET = V_{SS}$; XTAL2 = N.C.; XTAL1 = V_{SS} ; all other pins are disconnected. I_{DD} would be slightly higher if a crystal oscillator is used (appr. 1 mA).
- 4) I_{DD} (active mode) is measured with:
 XTAL2 driven with t_{CLCH} , $t_{CHCL} = 5$ ns, $V_{IL} = V_{SS} + 0.5$ V, $V_{IH} = V_{DD} - 0.5$ V; XTAL1 = N.C.;
 $EA = \overline{PE}/SWD = Port 0 = Port 6 = V_{DD}$; $\overline{HWPD} = V_{DD}$; $RESET = V_{DD}$;
 all other pins are disconnected. I_{DD} would be slightly higher if a crystal oscillator is used (appr. 1 mA).
- 5) I_{DD} (idle mode) is measured with all output pins disconnected and with all peripherals disabled;
 XTAL1 driven with t_{CLCH} , $t_{CHCL} = 5$ ns, $V_{IL} = V_{SS} + 0.5$ V, $V_{IH} = V_{DD} - 0.5$ V; XTAL2 = N.C.;
 $RESET = \overline{EA} = V_{SS}$; $Port0 = V_{DD}$; all other pins are disconnected.
- 6) I_{DD} (active mode with slow-down mode) is measured with all output pins disconnected and with all peripherals disabled; XTAL1 driven with t_{CLCH} , $t_{CHCL} = 5$ ns, $V_{IL} = V_{SS} + 0.5$ V, $V_{IH} = V_{DD} - 0.5$ V; XTAL2 = N.C.;
 $RESET = \overline{EA} = V_{SS}$; $Port0 = V_{DD}$; all other pins are disconnected.
- 7) I_{DD} (idle mode with slow-down mode) is measured with all output pins disconnected and with all peripherals disabled; XTAL1 driven with t_{CLCH} , $t_{CHCL} = 5$ ns, $V_{IL} = V_{SS} + 0.5$ V, $V_{IH} = V_{DD} - 0.5$ V; XTAL2 = N.C.;
 $RESET = \overline{EA} = V_{SS}$; $Port0 = V_{DD}$; all other pins are disconnected.
- 8) Overload conditions occur if the standard operating conditions are exceeded, i.e. the voltage on any pin exceeds the specified range (i.e. $V_{OV} > V_{DD} + 0.5$ V or $V_{OV} < V_{SS} - 0.5$ V). The supply voltage V_{DD} and V_{SS} must remain within the specified limits. The absolute sum of input currents on all port pins may not exceed 50 mA.
- 9) Not 100% tested, guaranteed by design characterization.
- 10) The typical I_{DD} values are periodically measured at $T_A = +25$ °C and $V_{DD} = 5$ V but not 100% tested.

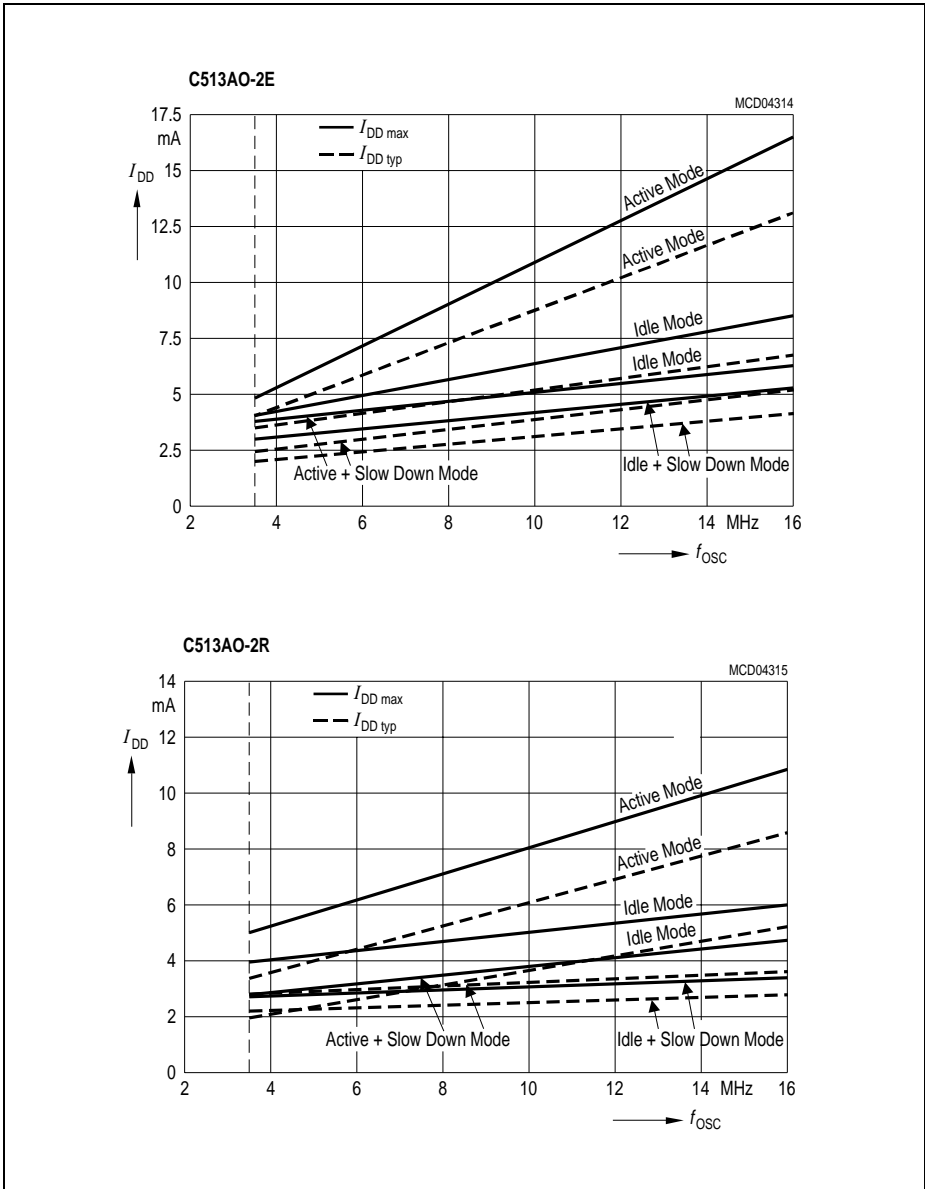

Figure 19
I_{DD} Diagram

Power Supply Current Calculation Formula

Parameter		Symbol	Formula
Active mode	C513-2E	$I_{DD \text{ typ}}$ $I_{DD \text{ max}}$	$0.70 \times f_{OSC} + 1.8$ $0.91 \times f_{OSC} + 2.0$
	C513-2R	$I_{DD \text{ typ}}$ $I_{DD \text{ max}}$	$0.40 \times f_{OSC} + 2.1$ $0.48 \times f_{OSC} + 3.2$
Idle mode	C513-2E	$I_{DD \text{ typ}}$ $I_{DD \text{ max}}$	$0.29 \times f_{OSC} + 2.2$ $0.36 \times f_{OSC} + 2.9$
	C513-2R	$I_{DD \text{ typ}}$ $I_{DD \text{ max}}$	$0.18 \times f_{OSC} + 1.9$ $0.13 \times f_{OSC} + 3.9$
Active mode with slow-down enabled	C513-2E	$I_{DD \text{ typ}}$ $I_{DD \text{ max}}$	$0.15 \times f_{OSC} + 2.6$ $0.20 \times f_{OSC} + 2.9$
	C513-2R	$I_{DD \text{ typ}}$ $I_{DD \text{ max}}$	$0.08 \times f_{OSC} + 2.4$ $0.10 \times f_{OSC} + 2.9$
Idle mode with slow-down enabled	C513-2E	$I_{DD \text{ typ}}$ $I_{DD \text{ max}}$	$0.09 \times f_{OSC} + 2.5$ $0.12 \times f_{OSC} + 3.2$
	C513-2R	$I_{DD \text{ typ}}$ $I_{DD \text{ max}}$	$0.05 \times f_{OSC} + 2.0$ $0.05 \times f_{OSC} + 2.7$

Note: f_{OSC} is the oscillator frequency in MHz. I_{DD} values are given in mA.

AC Characteristics (16 MHz)

(Operating Conditions apply)

 (C_L for port 0, ALE and $\overline{\text{PSEN}}$ outputs = 100 pF; C_L for all other outputs = 80 pF)

Parameter	Symbol	Limit Values				Unit
		16 MHz Clock		Variable Clock $1/t_{\text{CLCL}} = 3.5 \text{ MHz to } 16 \text{ MHz}$		
		min.	max.	min.	max.	

Program Memory Characteristics

ALE pulse width	t_{LHLL} CC	85	–	$2 t_{\text{CLCL}} - 40$	–	ns
Address setup to ALE	t_{AVLL} CC	33	–	$t_{\text{CLCL}} - 30$	–	ns
Address hold after ALE	t_{LLAX} CC	28	–	$t_{\text{CLCL}} - 35$	–	ns
ALE low to valid instruction in	t_{LLIV} SR	–	150	–	$4 t_{\text{CLCL}} - 100$	ns
ALE to $\overline{\text{PSEN}}$	t_{LLPL} CC	38	–	$t_{\text{CLCL}} - 25$	–	ns
$\overline{\text{PSEN}}$ pulse width	t_{PLPH} CC	153	–	$3 t_{\text{CLCL}} - 35$	–	ns
$\overline{\text{PSEN}}$ to valid instruction in	t_{PLIV} SR	–	88	–	$3 t_{\text{CLCL}} - 100$	ns
Input instruction hold after $\overline{\text{PSEN}}$	t_{PXIX} SR	0	–	0	–	ns
Input instruction float after $\overline{\text{PSEN}}$	$t_{\text{PXIZ}}^{*)}$ SR	–	43	–	$t_{\text{CLCL}} - 20$	ns
Address valid after $\overline{\text{PSEN}}$	$t_{\text{PXAV}}^{*)}$ CC	48	–	$t_{\text{CLCL}} - 8$	–	ns
Address to valid instr in	t_{AVIV} SR	–	198	–	$5 t_{\text{CLCL}} - 115$	ns
Address float to $\overline{\text{PSEN}}$	t_{AZPL} CC	0	–	0	–	ns

^{*)} Interfacing the C513AO to devices with float times up to 55 ns is permissible. This limited bus contention will not cause any damage to port 0 drivers.

AC Characteristics (16 MHz, cont'd)

(Operating Conditions apply)

 (C_L for port 0, ALE and PSEN outputs = 100 pF; C_L for all other outputs = 80 pF)

Parameter	Symbol	Limit Values				Unit
		16 MHz Clock		Variable Clock $1/t_{CLCL} = 3.5 \text{ MHz to } 16 \text{ MHz}$		
		min.	max.	min.	max.	

External Data Memory Characteristics

\overline{RD} pulse width	t_{RLRH} CC	275	–	$6 t_{CLCL} - 100$	–	ns
\overline{WR} pulse width	t_{WLWH} CC	275	–	$6 t_{CLCL} - 100$	–	ns
Address hold after ALE	t_{LLAX2} CC	90	–	$2 t_{CLCL} - 35$	–	ns
\overline{RD} to valid data in	t_{RLDV} SR	–	148	–	$5 t_{CLCL} - 165$	ns
Data hold after \overline{RD}	t_{RHDX} SR	0	–	0	–	ns
Data float after \overline{RD}	t_{RHDZ} SR	–	55	–	$2 t_{CLCL} - 70$	ns
ALE to valid data in	t_{LLDV} SR	–	350	–	$8 t_{CLCL} - 150$	ns
Address to valid data in	t_{AVDV} SR	–	398	–	$9 t_{CLCL} - 165$	ns
ALE to \overline{WR} or \overline{RD}	t_{LLWL} CC	138	238	$3 t_{CLCL} - 50$	$3 t_{CLCL} + 50$	ns
Address valid to \overline{WR} or \overline{RD}	t_{AVWL} CC	120	–	$4 t_{CLCL} - 130$	–	ns
\overline{WR} or \overline{RD} high to ALE high	t_{WHLH} CC	23	103	$t_{CLCL} - 40$	$t_{CLCL} + 40$	ns
Data valid to \overline{WR} transition	t_{QVWX} CC	13	–	$t_{CLCL} - 50$	–	ns
Data setup before \overline{WR}	t_{QVWH} CC	288	–	$7 t_{CLCL} - 150$	–	ns
Data hold after \overline{WR}	t_{WHQX} CC	13	–	$t_{CLCL} - 50$	–	ns
Address float after \overline{RD}	t_{RLAZ} CC	–	0	–	0	ns

Synchronous Serial Channel (SSC) Interface Characteristics

Parameter	Symbol	Limit Values		Unit
		16 MHz Clock		
		min.	max.	
Clock Cycle Time: Master Mode Slave Mode	t_{SCLK} CC	500	–	ns
	t_{SCLK} SR	450	–	ns
Clock High Time	t_{SCH} CC/SR ¹⁾	200	–	ns
Clock Low Time	t_{SCL} CC/SR ¹⁾	200	–	ns
Data Output Delay	t_D CC	–	100	ns
Data Output Hold	t_{HO} CC	0	–	ns
Data Input Setup	t_S SR	80	–	ns
Data Input Hold	t_{HI} SR	80	–	ns
TC Bit Set Delay	t_{DTC} CC	–	16 t_{CLCL}	ns

1) This parameter is 'CC' in Master Mode, and 'SR' in Slave Mode.

External Clock Drive Characteristics

Parameter	Symbol	Limit Values		Unit
		Variable Clock Freq. = 3.5 MHz to 16 MHz		
		min.	max.	
Oscillator period	t_{CLCL} SR	62.5	285	ns
High time	t_{CHCX} SR	15	$t_{CLCL} - t_{CLCX}$	ns
Low time	t_{CLCX} SR	15	$t_{CLCL} - t_{CHCX}$	ns
Rise time	t_{CLCH} SR	–	15	ns
Fall time	t_{CHCL} SR	–	15	ns

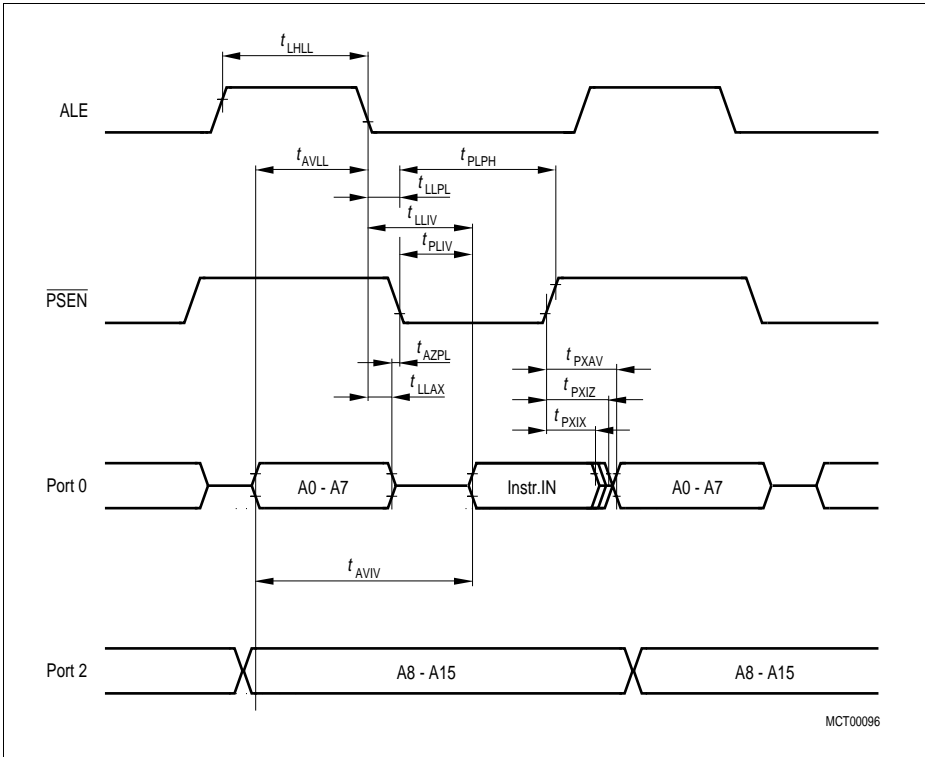

Figure 20
Program Memory Read Cycle

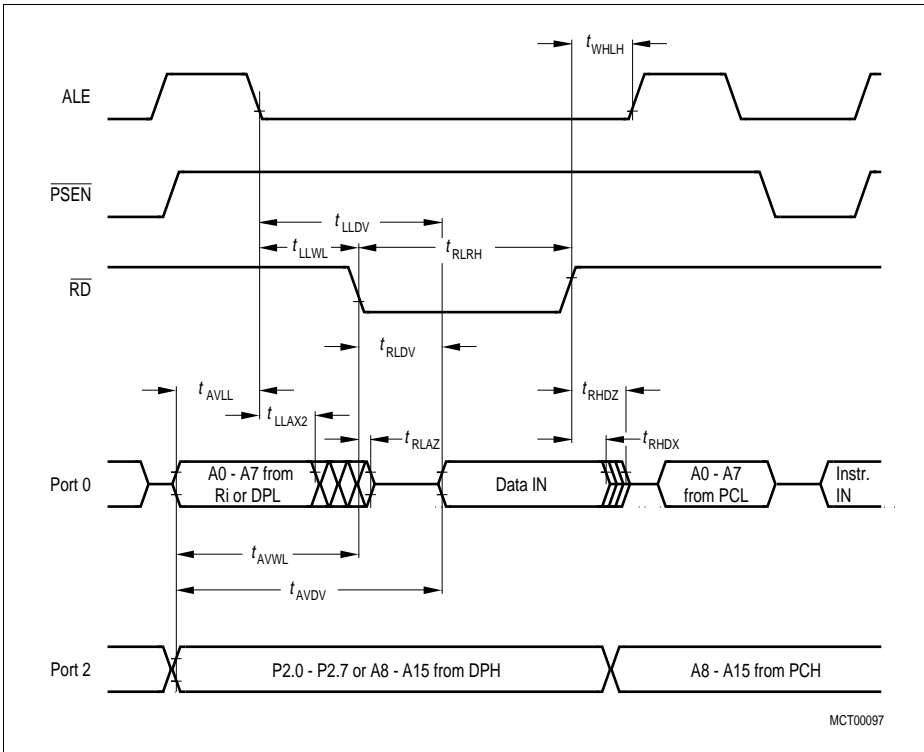

Figure 21
Data Memory Read Cycle

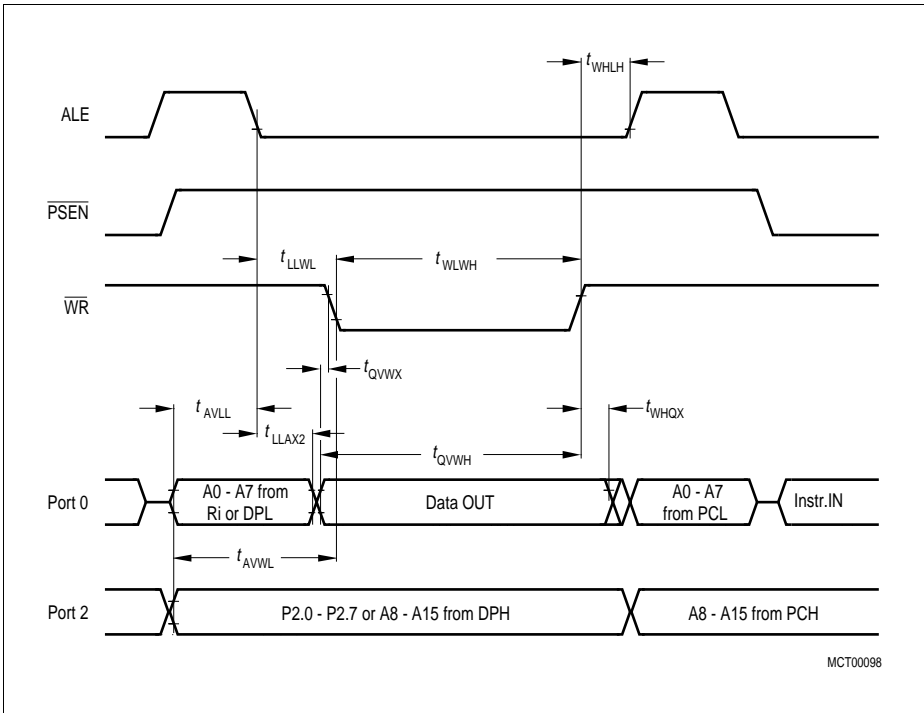
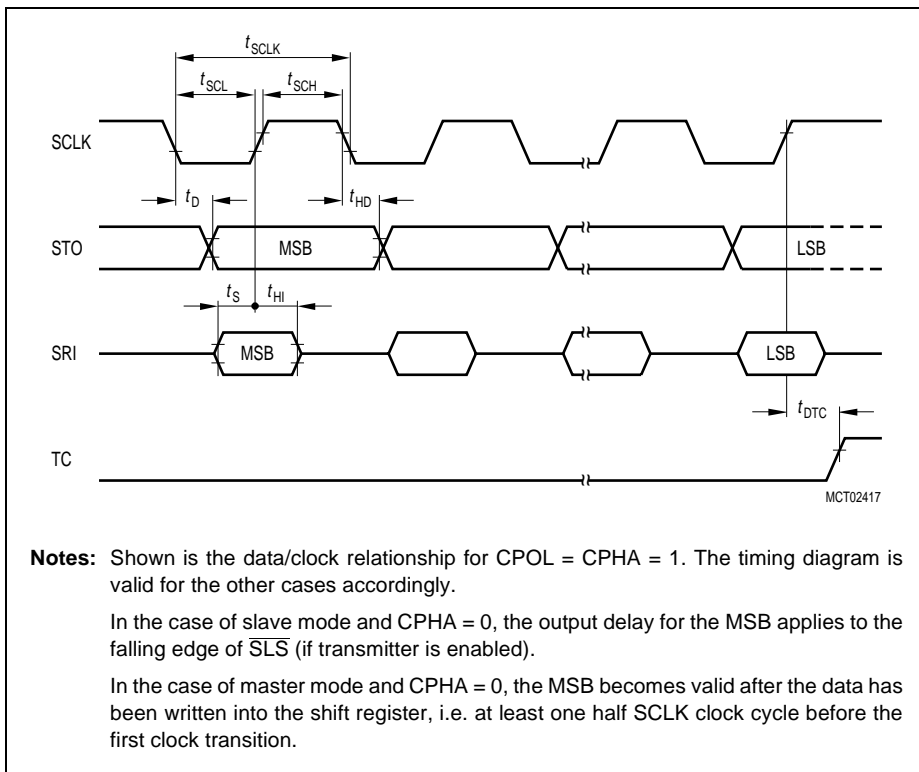

Figure 22
Data Memory Write Cycle



Notes: Shown is the data/clock relationship for CPOL = CPHA = 1. The timing diagram is valid for the other cases accordingly.

In the case of slave mode and CPHA = 0, the output delay for the MSB applies to the falling edge of \overline{SLS} (if transmitter is enabled).

In the case of master mode and CPHA = 0, the MSB becomes valid after the data has been written into the shift register, i.e. at least one half SCLK clock cycle before the first clock transition.

Figure 23
SSC Timing

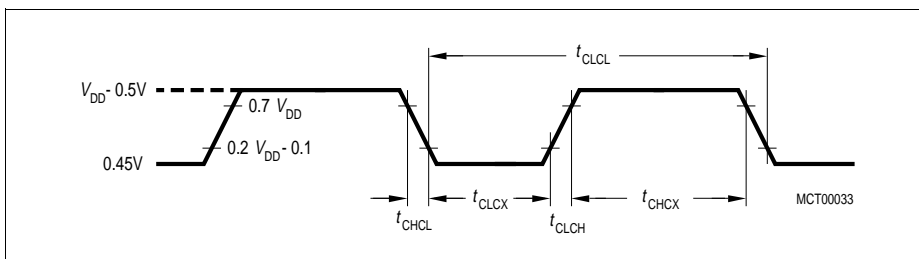

Figure 24
External Clock Drive on XTAL1

OTP Memory Characteristics (C513AO-2E only)
Programming Mode Timing Characteristics

(Operating Conditions apply)

Parameter	Symbol	Limit Values		Unit
		min.	max.	
PALE Pulse Width	t_{PAW}	35	–	ns
PMSEL Set-up to PALE Rising Edge	t_{PMS}	10	–	–
Address Set-up to PALE, \overline{PROG} , or \overline{PRD} Falling Edge	t_{PAS}	10	–	ns
Address Hold after PALE, \overline{PROG} , or \overline{PRD} Falling Edge	t_{PAH}	10	–	ns
Address, Data Set-up to \overline{PROG} or \overline{PRD}	t_{PCS}	100	–	ns
Address, Data Hold after \overline{PROG} or \overline{PRD}	t_{PCH}	0	–	ns
PMSEL Set-up to \overline{PROG} or \overline{PRD}	t_{PMS}	10	–	ns
PMSEL Hold after \overline{PROG} or \overline{PRD}	t_{PMH}	10	–	ns
\overline{PROG} Pulse Width	t_{PWW}	100	–	μ s
\overline{PRD} Pulse Width	t_{PRW}	100	–	ns
Address to Valid Data out	t_{PAD}	–	75	ns
\overline{PRD} to Valid Data out	t_{PRD}	–	20	ns
Data Hold after \overline{PRD}	t_{PDH}	0	–	ns
Data float after \overline{PRD}	t_{PDF}	–	20	ns
\overline{PROG} High between two Consecutive \overline{PROG} Low Pulses	t_{PWH1}	1	–	μ s
\overline{PRD} High between two Consecutive \overline{PRD} Low Pulses	t_{PWH2}	100	–	ns
XTAL Clock Period	t_{CLKP}	62.5	286	ns

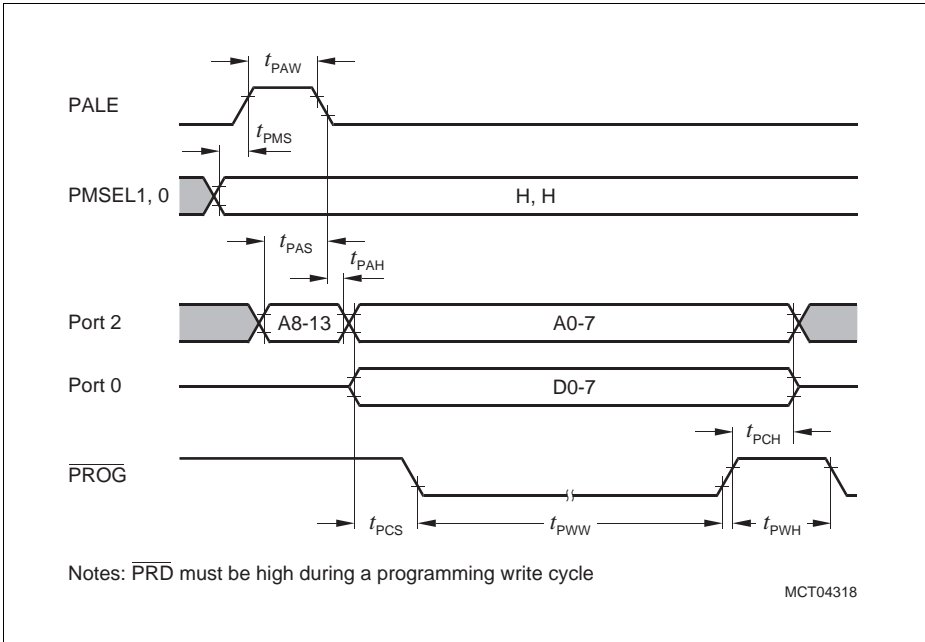

Figure 25
Programming Code Byte - Write Cycle Timing

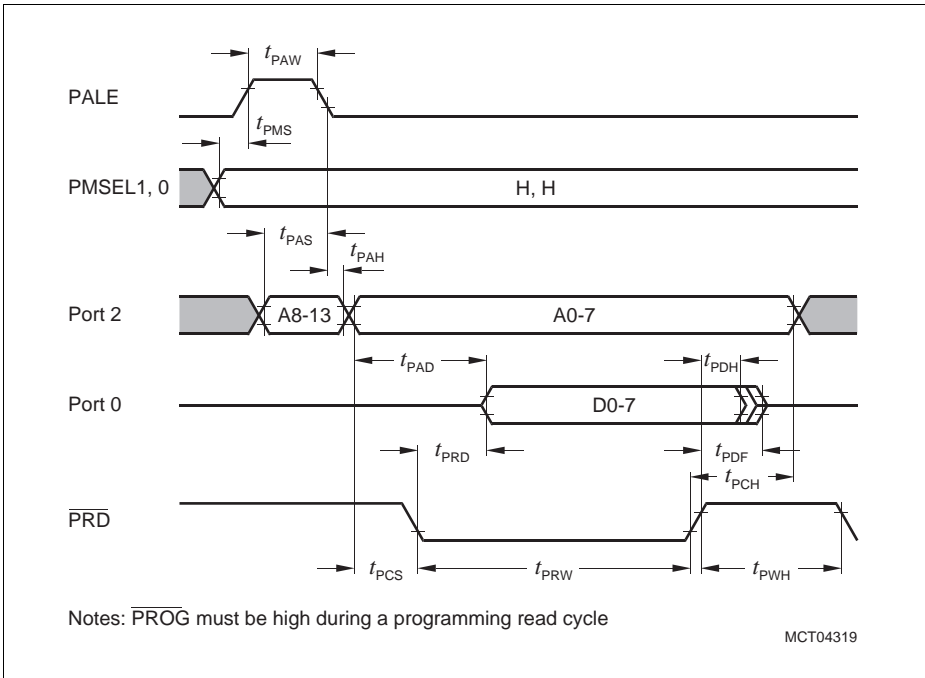

Figure 26
Verify Code Byte - Read Cycle Timing

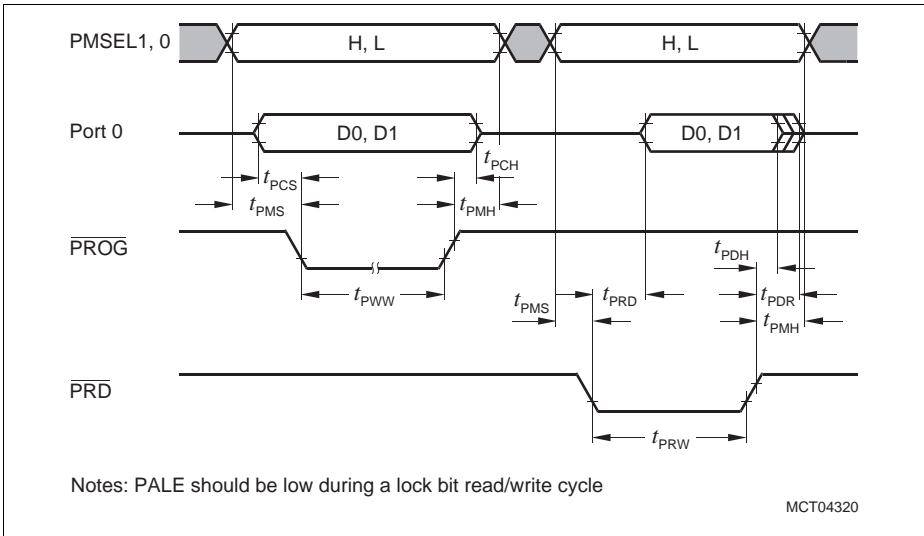

Figure 27
Lock Bit Access Timing

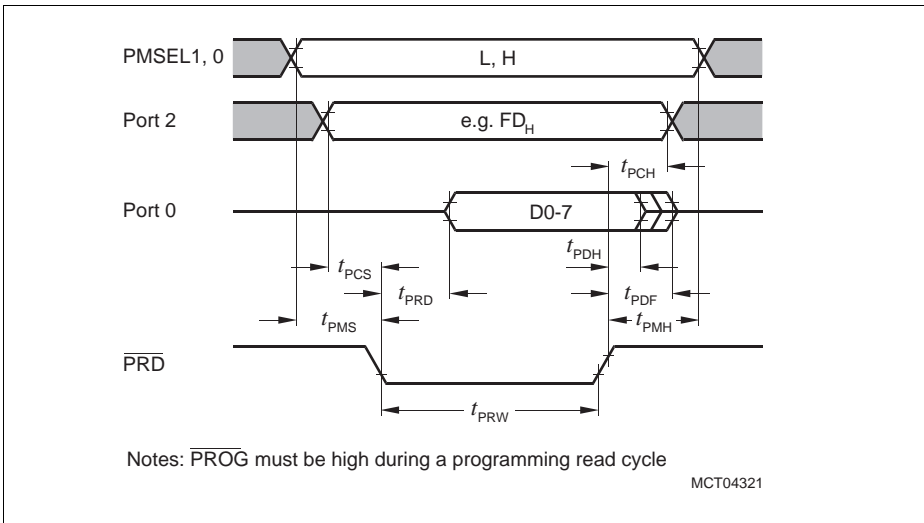

Figure 28
Version Registers - Read Timing

OTP Verification Mode Characteristics

Note: ALE pin described below is **not** the OTP Programming Mode pin PALE

Parameter	Symbol	Limit Values			Unit
		min.	typ	max.	
ALE Pulse Width	t_{AWD}	–	$2 t_{CLCL}$	–	ns
ALE Period	t_{ACY}	–	$12 t_{CLCL}$	–	ns
Data Valid after ALE	t_{DVA}	–	–	$4 t_{CLCL}$	ns
Data Stable after ALE	t_{DSA}	$8 t_{CLCL}$	–	–	ns
P3.5 Set-up to ALE Low	t_{AS}	–	t_{CLCL}	–	ns
Oscillator Frequency	$1/t_{CLCL}$	4	–	6	MHz

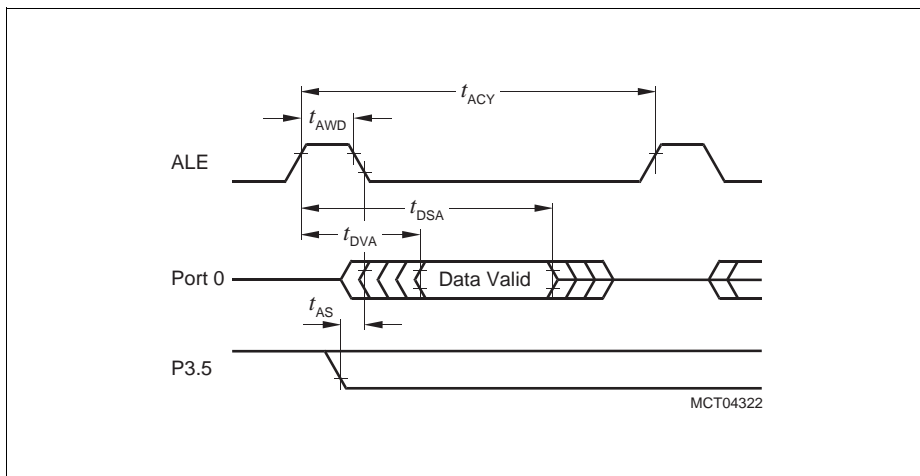

Figure 29
OTP Verification Mode

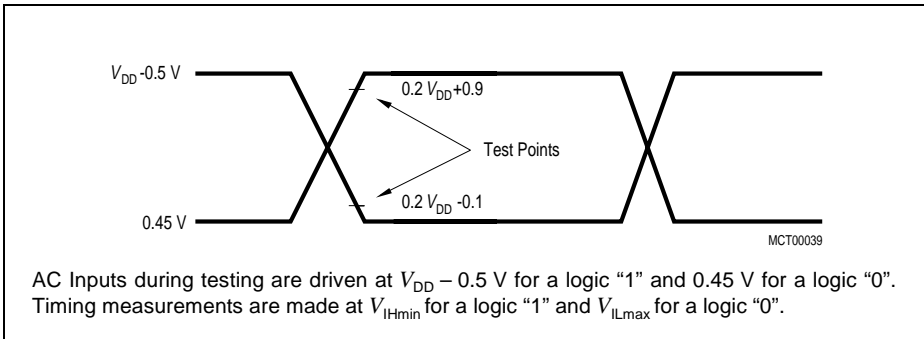

Figure 30
AC Testing: Input, Output Waveforms

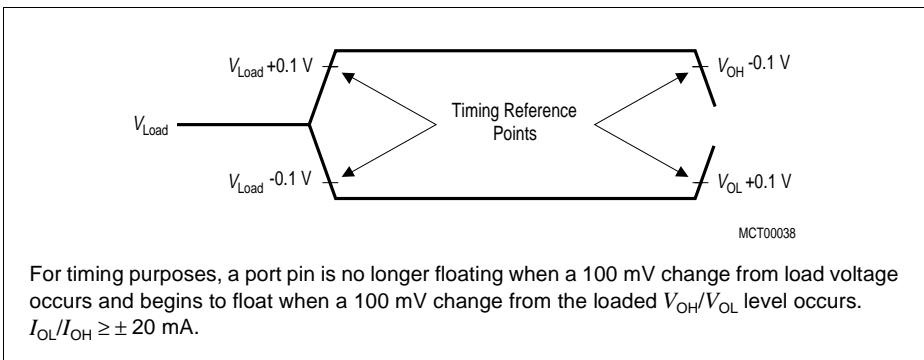

Figure 31
AC Testing: Float Waveforms

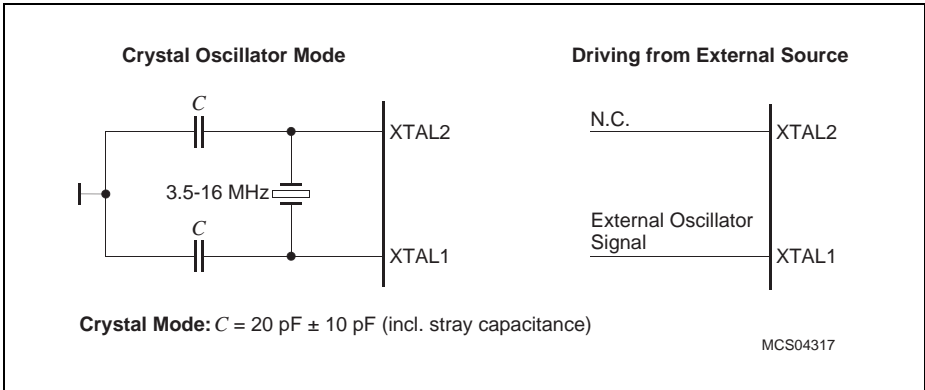
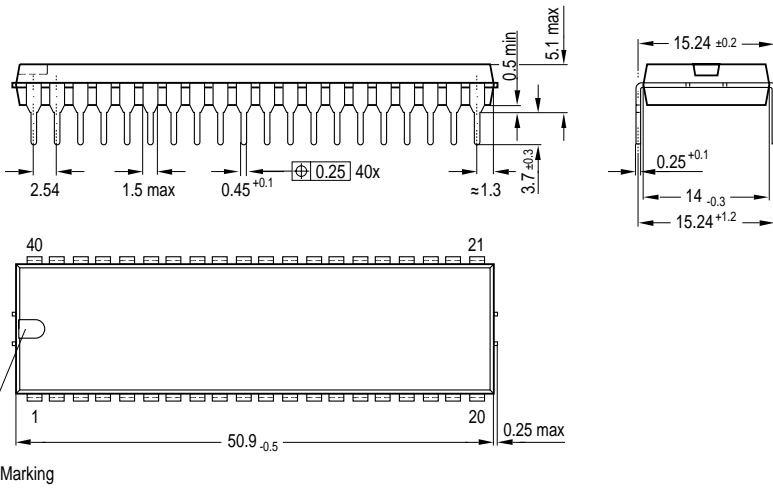

Figure 32
Recommended Oscillator Circuits for Crystal Oscillator

Package Outlines

Plastic Package, P-DIP-40-2
(Plastic Dual In-Line Package)



GPD05055

Sorts of Packing

Package outlines for tubes, trays etc. are contained in our Data Book "Package Information".

SMD = Surface Mounted Device

Dimensions in mm

Plastic Package, P-LCC-44-1
(Plastic Lead Chip Carrier)

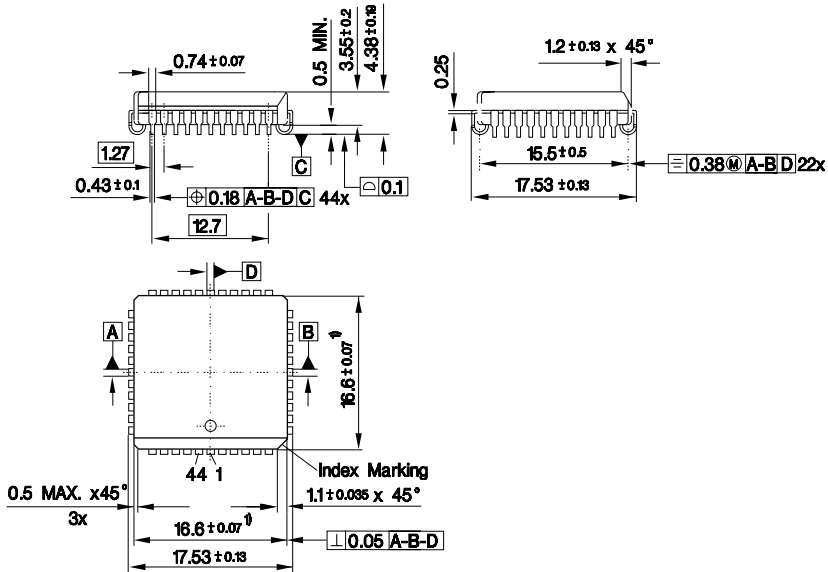

1) Does not include plastic or metal protrusion of 0.15 max. per side

GPL05102

Sorts of Packing

Package outlines for tubes, trays etc. are contained in our Data Book "Package Information".

SMD = Surface Mounted Device

Dimensions in mm

