

## Enhanced Full Duplex RS-485 Transceivers

- +5V Only
- Low Power BiCMOS
- Driver/Receiver Enable (**SP491E**)
- RS-485 and RS-422 Drivers/Receivers
- Pin Compatible with LTC490 and SN75179 (**SP490E**)
- Pin Compatible with LTC491 and SN75180 (**SP491E**)
- Improved ESD Specifications:
  - ±15kV Human Body Model
  - ±15kV IEC1000-4-2 Air Discharge
  - ±8kV IEC1000-4-2 Contact Discharge

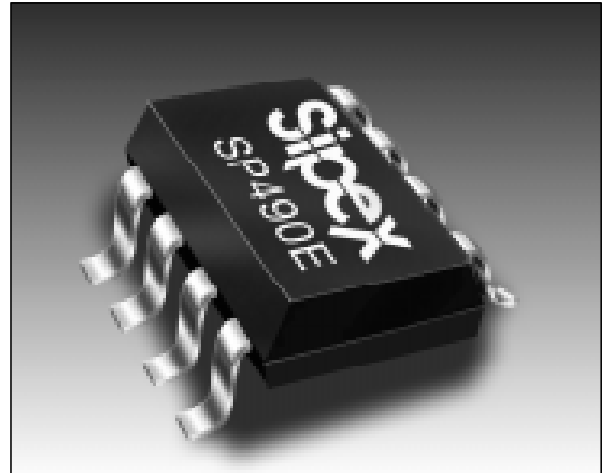

### DESCRIPTION...

The **SP490E** is a low power differential line driver/receiver meeting RS-485 and RS-422 standards up to 10Mbps. The **SP491E** is identical to the **SP490E** with the addition of driver and receiver tri-state enable lines. Both products feature  $\pm 200\text{mV}$  receiver input sensitivity, over wide common mode range. The **SP490E** is available in 8-pin plastic DIP and 8-pin NSOIC packages for operation over the commercial and industrial temperature ranges. The **SP491E** is available in 14-pin DIP and 14-pin NSOIC packages for operation over the commercial and industrial temperature ranges.

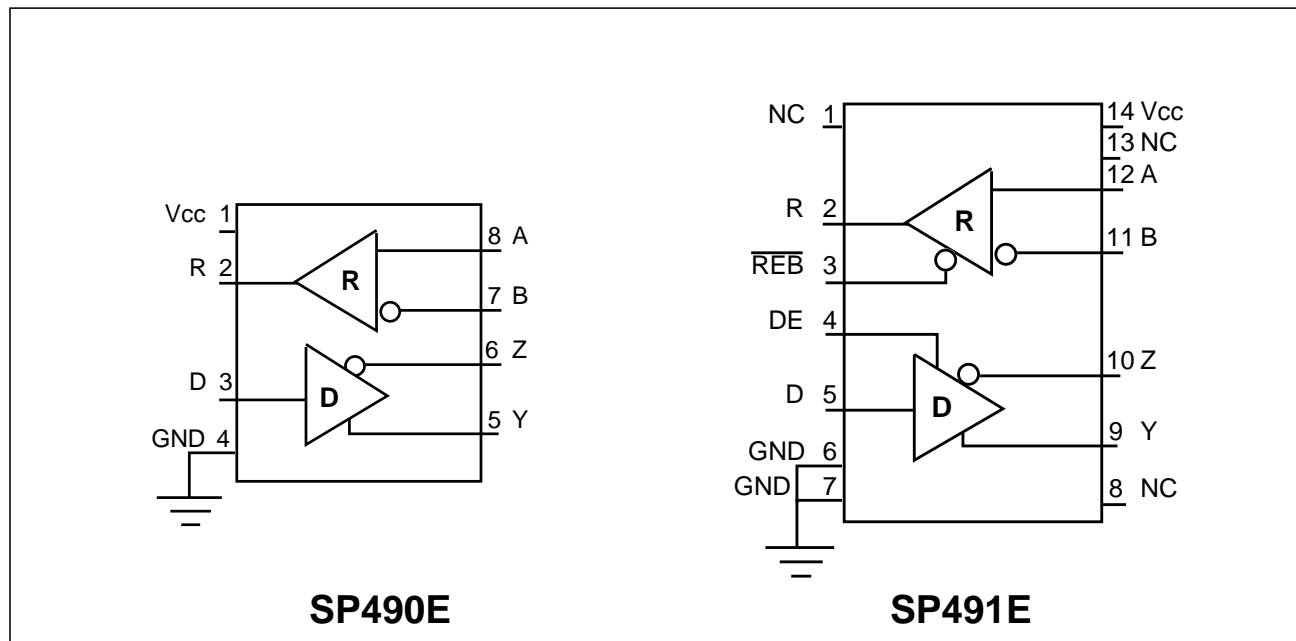

## ABSOLUTE MAXIMUM RATINGS

These are stress ratings only and functional operation of the device at these ratings or any other above those indicated in the operation sections of the specifications below is not implied. Exposure to absolute maximum rating conditions for extended periods of time may affect reliability.

$V_{CC}$ .....	+7V
Input Voltages	
Drivers.....	-0.5V to ( $V_{CC}+0.5V$ )
Receivers.....	$\pm 14V$
Output Voltages	
Drivers.....	$\pm 14V$
Receivers.....	-0.5V to ( $V_{CC}+0.5V$ )
Storage Temperature.....	-65°C to +150°
Power Dissipation.....	1000mW

## SPECIFICATIONS

$T_{MIN}$  to  $T_{MAX}$  and  $V_{CC} = 5V \pm 5\%$  unless otherwise noted.

PARAMETERS	MIN.	TYP.	MAX.	UNITS	CONDITIONS
<b>SP490E DRIVER</b>					
<b>DC Characteristics</b>					
Differential Output Voltage	GND		$V_{CC}$	Volts	Unloaded; $R = \infty$ ; see Figure 1
Differential Output Voltage	2		$V_{CC}$	Volts	With Load; $R = 50\Omega$ ; (RS-422); see Figure 1
Differential Output Voltage Change in Magnitude of Driver	1.5		$V_{CC}$	Volts	With Load; $R = 27\Omega$ ; (RS-485); see Figure 1
Differential Output Voltage for Complimentary States			0.2	Volts	$R = 27\Omega$ or $R = 50\Omega$ ; see Figure 1
Driver Common-Mode Output Voltage			3	Volts	$R = 27\Omega$ or $R = 50\Omega$ ; see Figure 1
Input High Voltage	2.0			Volts	Applies to D
Input Low Voltage			0.8	Volts	Applies to D
Input Current			$\pm 10$	$\mu A$	Applies to D
Driver Short-Circuit Current					
$V_{OUT} = HIGH$			$\pm 250$	mA	$-7V \leq V_O \leq +12V$
$V_{OUT} = LOW$			$\pm 250$	mA	$-7V \leq V_O \leq +12V$
<b>SP490E DRIVER</b>					
<b>AC Characteristics</b>					
Maximum Data Rate	10			Mbps	$R_{DIFF} = 54\Omega$ , $C_{L1} = C_{L2} = 100pF$
Driver Input to Output	20	30	60	ns	$t_{PLH}$ ; $R_{DIFF} = 54\Omega$ , $C_{L1} = C_{L2} = 100pF$ ; see Figures 3 and 6
Driver Input to Output	20	30	60	ns	$t_{PHL}$ ; $R_{DIFF} = 54\Omega$ , $C_{L1} = C_{L2} = 100pF$ ; see Figures 3 and 5
Driver Skew		5		ns	see Figures 3 and 5,
Driver Rise or Fall Time	3	15	40	ns	$t_{SKEW} =  t_{DPLH} - t_{DPHL} $ From 10% to 90%; $R_{DIFF} = 54\Omega$ , $C_{L1} = C_{L2} = 100pF$ ; see Figures 3 and 5
<b>SP490E RECEIVER</b>					
<b>DC Characteristics</b>					
Differential Input Threshold	-0.2		+0.2	Volts	$-7V \leq V_{CM} \leq 12V$
Input Hysteresis		70		mV	$V_{CM} = 0V$
Output Voltage High	3.5			Volts	$I_O = -4mA$ , $V_{ID} = +200mV$
Output Voltage Low			0.4	Volts	$I_O = +4mA$ , $V_{ID} = -200mV$
Input Resistance	12	15		k $\Omega$	$-7V \leq V_{CM} \leq 12V$
Input Current (A, B); $V_{IN} = 12V$			$\pm 1.0$	mA	$V_{IN} = 12V$
Input Current (A, B); $V_{IN} = -7V$			-0.8	mA	$V_{IN} = -7V$
Short-Circuit Current			85	mA	$0V \leq V_O \leq V_{CC}$

# SPECIFICATIONS (continued)

$T_{MIN}$  to  $T_{MAX}$  and  $V_{CC} = 5V \pm 5%$  unless otherwise noted.

PARAMETERS	MIN.	TYP.	MAX.	UNITS	CONDITIONS
<b>SP490E RECEIVER</b>					
<b>AC Characteristics</b>					
Maximum Data Rate	10			Mbps	
Receiver Input to Output	20	45	100	ns	$t_{PLH}$ ; $R_{DIFF} = 54\Omega$ , $C_{L1} = C_{L2} = 100pF$ ; Figures 3 & 7
Receiver Input to Output	20	45	100	ns	$t_{PHL}$ ; $R_{DIFF} = 54\Omega$ , $C_{L1} = C_{L2} = 100pF$ ; Figures 3 & 7
Diff. Receiver Skew $t_{PLH} - t_{PHL}$		13		ns	$R_{DIFF} = 54\Omega$ ; $C_{L1} = C_{L2} = 100pF$ ; Figures 3 & 7
<b>POWER REQUIREMENTS</b>					
Supply Voltage	+4.75		+5.25	Volts	
Supply Current		900		$\mu A$	
<b>ENVIRONMENTAL AND MECHANICAL</b>					
Operating Temperature					
Commercial (_C_)	0		+70	$^{\circ}C$	
Industrial (_E_)	-40		+85	$^{\circ}C$	
Storage Temperature	-65		+150	$^{\circ}C$	
Package					
Plastic DIP (_P)					
NSOIC (_N)					

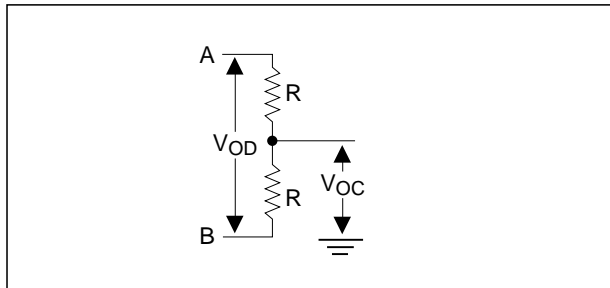

Figure 1. Driver DC Test Load Circuit

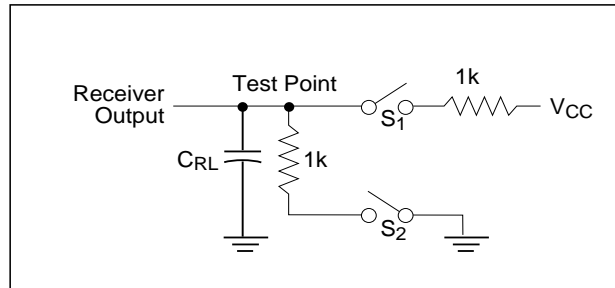

Figure 2. Receiver Timing Test Load Circuit

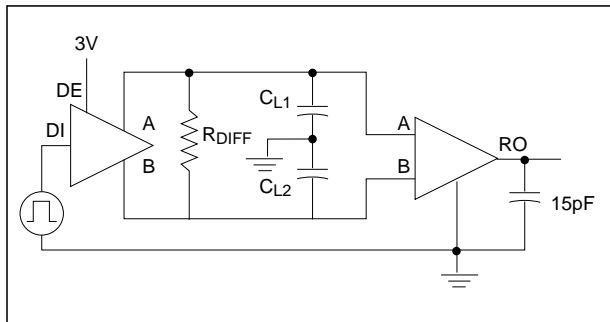

Figure 3. Driver/Receiver Timing Test Circuit

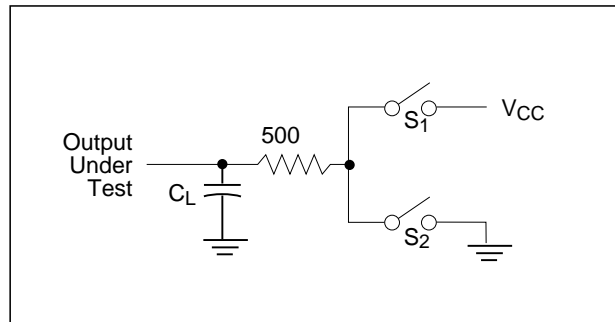

Figure 4. Driver Timing Test Load #2 Circuit

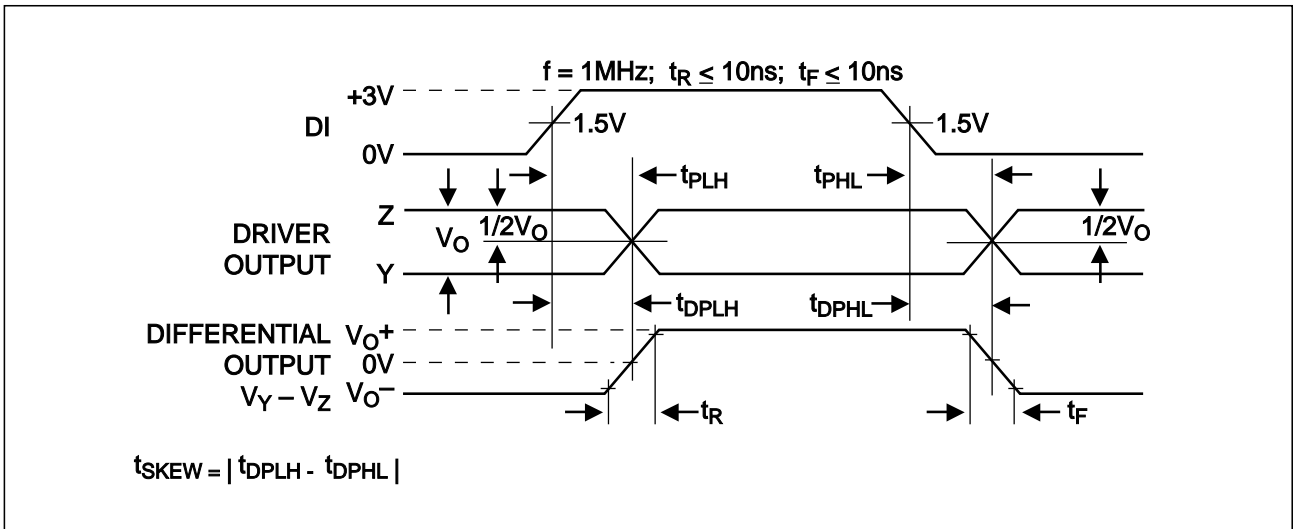

Figure 5. Driver Propagation Delays

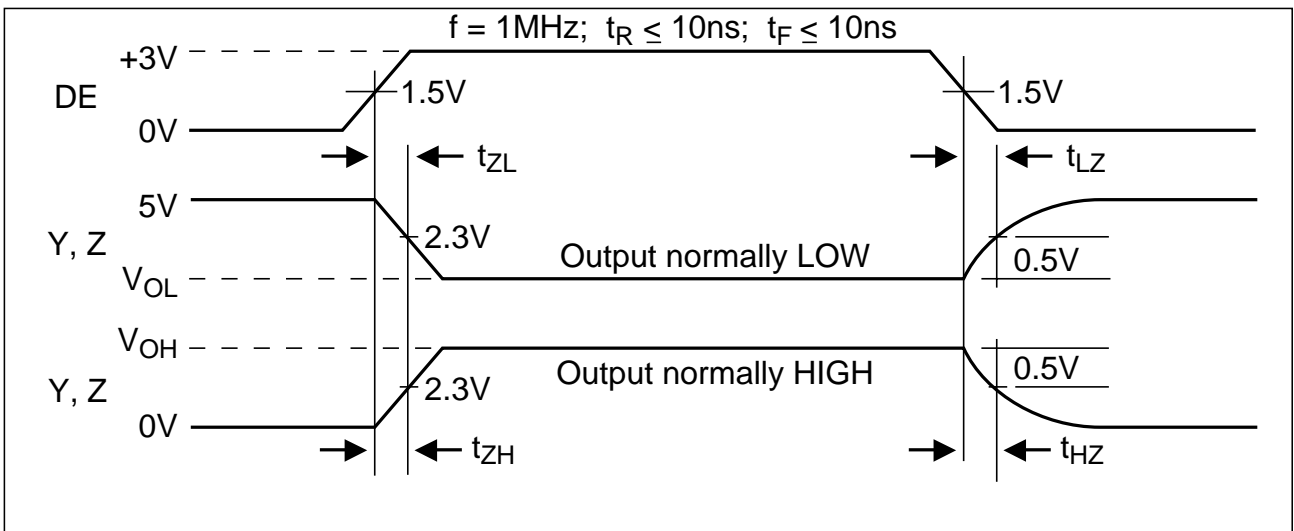

Figure 6. Driver Enable and Disable Times

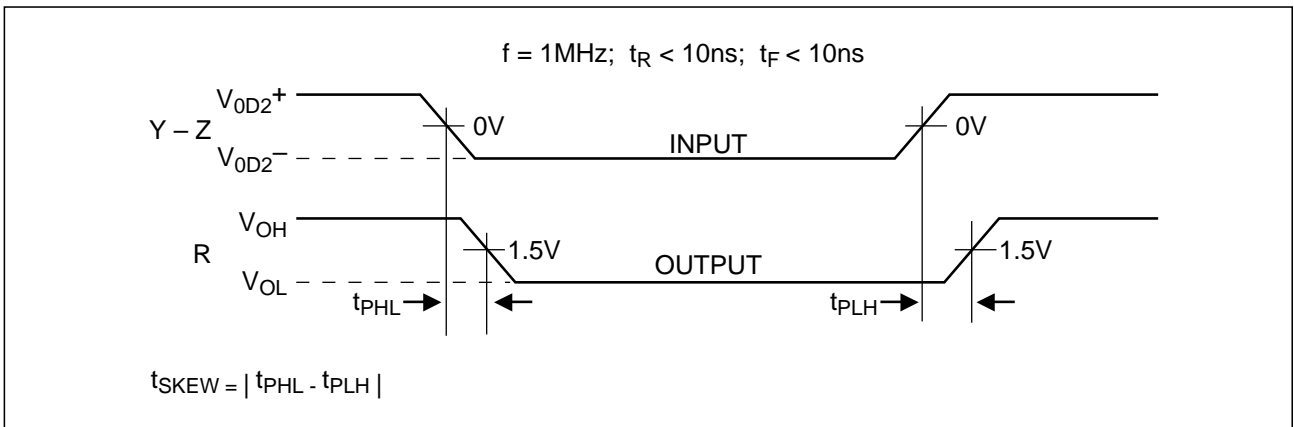

Figure 7. Receiver Propagation Delays

## ABSOLUTE MAXIMUM RATINGS

These are stress ratings only and functional operation of the device at these ratings or any other above those indicated in the operation sections of the specifications below is not implied. Exposure to absolute maximum rating conditions for extended periods of time may affect reliability.

$V_{CC}$ .....	+7V
Input Voltages	
Logic.....	-0.5V to ( $V_{CC}$ +0.5V)
Drivers.....	-0.5V to ( $V_{CC}$ +0.5V)
Receivers.....	$\pm$ 14V
Output Voltages	
Logic.....	-0.5V to ( $V_{CC}$ +0.5V)
Drivers.....	$\pm$ 14V
Receivers.....	-0.5V to ( $V_{CC}$ +0.5V)
Storage Temperature.....	-65°C to +150
Power Dissipation.....	1000mW

## SPECIFICATIONS

$T_{MIN}$  to  $T_{MAX}$  and  $V_{CC} = 5V \pm 5\%$  unless otherwise noted.

PARAMETERS	MIN.	TYP.	MAX.	UNITS	CONDITIONS
<b>SP491E DRIVER</b>					
<b>DC Characteristics</b>					
Differential Output Voltage	GND		$V_{CC}$	Volts	Unloaded; $R = \infty$ ; see Figure 1
Differential Output Voltage	2		$V_{CC}$	Volts	With Load; $R = 50\Omega$ ; (RS-422); see Figure 1
Differential Output Voltage	1.5		$V_{CC}$	Volts	With Load; $R = 27\Omega$ ; (RS-485); see Figure 1
Change in Magnitude of Driver Differential Output Voltage for Complimentary States			0.2	Volts	$R = 27\Omega$ or $R = 50\Omega$ ; see Figure 1
Driver Common-Mode Output Voltage			3	Volts	$R = 27\Omega$ or $R = 50\Omega$ ; see Figure 1
Input HIGH Voltage	2.0			Volts	Applies to D, REB, DE
Input LOW Voltage			0.8	Volts	Applies to D, REB, DE
Input Current			$\pm 10$	$\mu A$	Applies to D, REB, DE
Driver Short-Circuit Current			250	mA	$-7V \leq V_O \leq 10V$
$V_{OUT} = HIGH$			250	mA	$-7V \leq V_O \leq 10V$
$V_{OUT} = LOW$					
<b>SP491E DRIVER</b>					
<b>AC Characteristics</b>					
Maximum Data Rate	10			Mbps	$R_{DIFF} = 54\Omega$ , $C_{L1} = C_{L2} = 100pF$
Driver Input to Output	20	30	60	ns	$t_{PLH}$ ; $R_{DIFF} = 54\Omega$ , $C_{L1} = C_{L2} = 100pF$ ; see Figures 3 and 5
Driver Input to Output	20	30	60	ns	$t_{PHL}$ ; $R_{DIFF} = 54\Omega$ , $C_{L1} = C_{L2} = 100pF$ ; see Figures 3 and 5
Driver Skew		5	10	ns	see Figures 3 and 5,
Driver Rise or Fall Time	3	15	40	ns	$t_{SKEW} =  t_{DPLH} - t_{DPHL} $ From 10% to 90%; $R_{DIFF} = 54\Omega$ , $C_{L1} = C_{L2} = 100pF$ ; see Figures 3 and 5
Driver Enable to Output HIGH		40	70	ns	$C_{L1} = C_{L2} = 100pF$ ; see Figures 4 and 6; $S_2$ closed
Driver Enable to Output LOW		40	70	ns	$C_{L1} = C_{L2} = 100pF$ ; see Figures 4 and 6; $S_1$ closed
Driver Disable Time from LOW		40	70	ns	$C_{L1} = C_{L2} = 15pF$ ; see Figures 4 and 6; $S_1$ closed
Driver Disable Time from HIGH		40	70	ns	$C_{L1} = C_{L2} = 15pF$ ; see Figures 4 and 6; $S_2$ closed

# SPECIFICATIONS (continued)

$T_{MIN}$  to  $T_{MAX}$  and  $V_{CC} = 5V \pm 5\%$  unless otherwise noted.

PARAMETERS	MIN.	TYP.	MAX.	UNITS	CONDITIONS
<b>SP491E RECEIVER</b>					
<b>DC Characteristics</b>					
Differential Input Threshold	-0.2		+0.2	Volts	$-7V \leq V_{CM} \leq 12V$
Input Hysteresis		70		mV	$V_{CM} = 0V$
Output Voltage HIGH	3.5			Volts	$I_O = -4mA, V_{ID} = +200mV$
Output Voltage LOW			0.4	Volts	$I_O = +4mA, V_{ID} = -200mV$
Three State (high impedance)					
Output Current			$\pm 1$	$\mu A$	$0.4V \leq V_O \leq 2.4V; \overline{REB} = 5V$
Input Resistance	12	15		k $\Omega$	$-7V \leq V_{CM} \leq 12V$
Input Current (A, B); $V_{IN} = 12V$			$\pm 1.0$	mA	$DE = 0V, V_{CC} = 0V$ or $5.25V, V_{IN} = 12V$
Input Current (A, B); $V_{IN} = -7V$			-0.8	mA	$DE = 0V, V_{CC} = 0V$ or $5.25V, V_{IN} = -7V$
Short-Circuit Current			85	mA	$0V \leq V_O \leq V_{CC}$
<b>SP491E RECEIVER</b>					
<b>AC Characteristics</b>					
Maximum Data Rate	10			Mbps	$\overline{REB} = 0V, DE = 5V$
Receiver Input to Output	20	45	100	ns	$t_{PLH}; R_{DIFF} = 54\Omega,$ $C_{L1} = C_{L2} = 100pF; Figures 3 \& 7$
Receiver Input to Output	20	45	100	ns	$t_{PHL}; R_{DIFF} = 54\Omega,$ $C_{L1} = C_{L2} = 100pF; Figures 3 \& 7$
Diff. Receiver Skew $ t_{PLH} - t_{PHL} $		13		ns	$R_{DIFF} = 54\Omega; C_{L1} = C_{L2} = 100pF;$ <i>Figures 3 &amp; 7</i>
Receiver Enable to Output LOW		45	70	ns	$C_{RL} = 15pF; Figures 2 \text{ and } 8; S_1 \text{ closed}$
Receiver Enable to Output HIGH		45	70	ns	$C_{RL} = 15pF; Figures 2 \text{ and } 8; S_2 \text{ closed}$
Receiver Disable from LOW		45	70	ns	$C_{RL} = 15pF; Figures 2 \text{ and } 8; S_1 \text{ closed}$
Receiver Disable from HIGH		45	70	ns	$C_{RL} = 15pF; Figures 2 \text{ and } 8; S_2 \text{ closed}$
<b>POWER REQUIREMENTS</b>					
Supply Voltage	+4.75		+5.25	Volts	
Supply Current		900		$\mu A$	$\overline{REB}, D = 0V$ or $V_{CC}; DE = V_{CC}$
<b>SP491E ENVIRONMENTAL AND MECHANICAL</b>					
Operating Temperature					
Commercial ( $_{C}$ )	0		+70	$^{\circ}C$	
Industrial ( $_{E}$ )	-40		+85	$^{\circ}C$	
Storage Temperature	-65		+150	$^{\circ}C$	
Package					
Plastic DIP ( $_{P}$ )					
NSOIC ( $_{N}$ )					

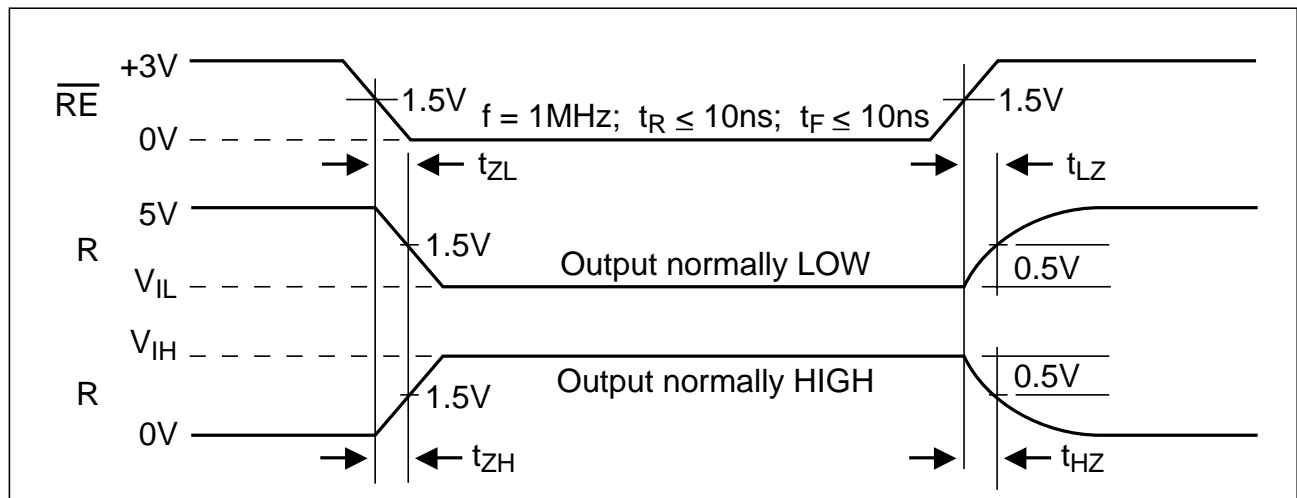

Figure 8. Receiver Enable and Disable Times

## FEATURES

The **SP490E** and **SP491E** are full-duplex differential transceivers that meet the requirements of RS-485 and RS-422. Fabricated with a **Sipex** proprietary BiCMOS process, both products require a fraction of the power of older bipolar designs.

## THEORY OF OPERATION

The RS-485 standard is ideal for multi-drop applications or for long-distance interfaces. RS-485 allows up to 32 drivers and 32 receivers to be connected to a data bus, making it an ideal choice for multi-drop applications. Since the cabling can be as long as 4,000 feet, RS-485 transceivers are equipped with a wide (-7V to +12V) common mode range to accommodate ground potential differences. Because RS-485 is a differential interface, data is virtually immune to noise in the transmission line.

### Drivers

The drivers for both the **SP490E** and **SP491E** have differential outputs. The typical voltage output swing with no load will be 0 volts to +5 volts. With worst case loading of 54 $\Omega$  across the differential outputs, the driver can maintain greater than 1.5V voltage levels.

The driver of the **SP491E** has a driver enable control line which is active high. A logic high on DE (pin 4) of the **SP491E** will enable the differential driver outputs. A logic low on DE (pin 4) of the **SP491E** will tri-state the driver outputs. The **SP490E** does not have a driver enable.

### Receivers

The receivers for both the **SP490E** and **SP491E** have differential inputs with an input sensitivity as low as  $\pm 200\text{mV}$ . Input impedance of the receivers is typically 15k $\Omega$  (12k $\Omega$  minimum). A wide common mode range of -7V to +12V allows for large ground potential differences between systems. The receivers for both the **SP490E** and **SP491E** are equipped with the fail-safe feature. Fail-safe guarantees that the receiver output will be in a high state when the input is left unconnected.

The receiver of the **SP491E** has a receiver enable control line which is active low. A logic low on  $\overline{\text{REB}}$  (pin 3) of the **SP491E** will enable the differential receiver. A logic high on  $\overline{\text{REB}}$  (pin 3) of the **SP491E** will tri-state the receiver.

### ESD Tolerance

The **SP490E/SP491E** devices incorporate ruggedized ESD cells on all driver output and receiver input pins. The ESD structure is improved over our previous family for more rugged applications and environments sensitive to electro-static discharges and associated transients. The improved ESD tolerance is at least  $\pm 15\text{kV}$  without damage nor latch-up.

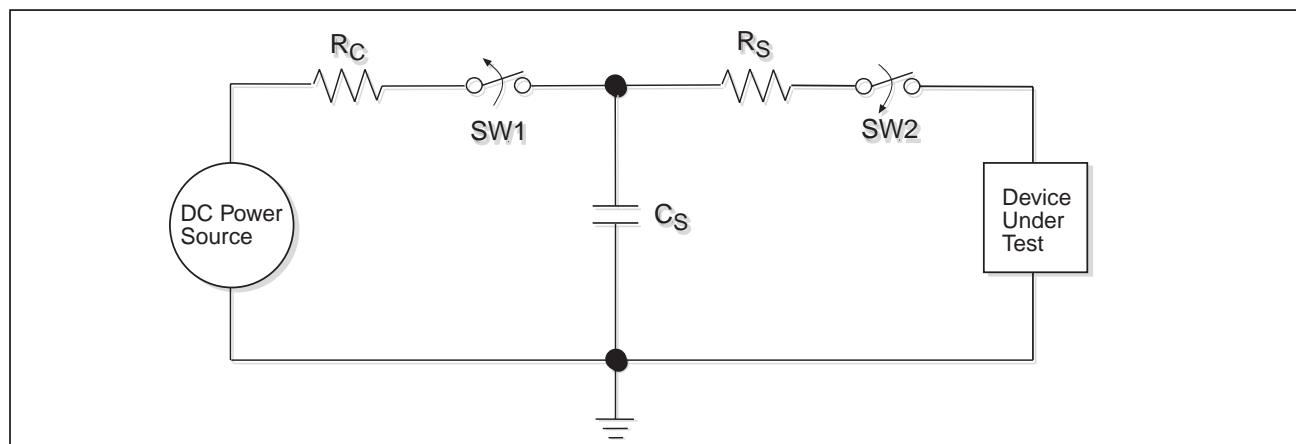

Figure 9. ESD Test Circuit for Human Body Model

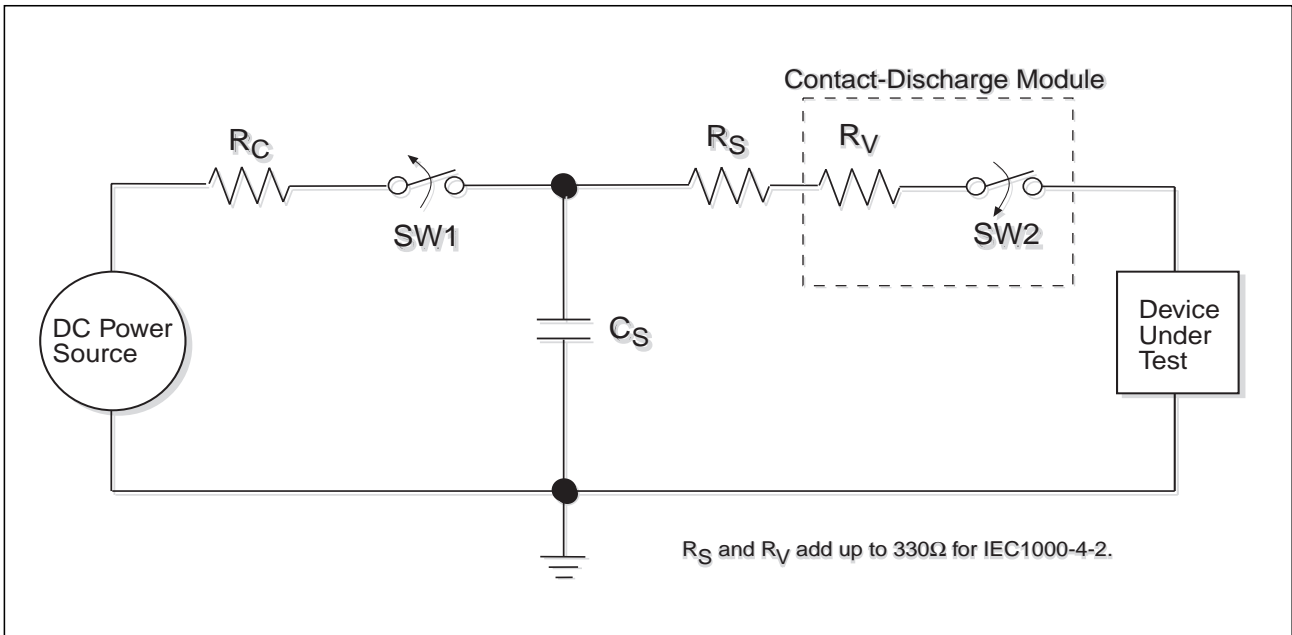

Figure 10. ESD Test Circuit for IEC1000-4-2

There are different methods of ESD testing applied:

- a) MIL-STD-883, Method 3015.7
- b) IEC1000-4-2 Air-Discharge
- c) IEC1000-4-2 Direct Contact

The Human Body Model has been the generally accepted ESD testing method for semiconductors. This method is also specified in MIL-STD-883, Method 3015.7 for ESD testing. The premise of this ESD test is to simulate the human body's potential to store electro-static energy and discharge it to an integrated circuit. The simulation is performed by using a test model as shown in Figure 9. This method will test the IC's capability to withstand an ESD transient during normal handling such as in manufacturing areas where the ICs tend to be handled frequently.

The IEC-1000-4-2, formerly IEC801-2, is generally used for testing ESD on equipment and systems. For system manufacturers, they must guarantee a certain amount of ESD protection since the system itself is exposed to the outside environment and human presence. The premise with IEC1000-4-2 is that the system is required to withstand an amount of static electricity when ESD is applied to points and surfaces of the

equipment that are accessible to personnel during normal usage. The transceiver IC receives most of the ESD current when the ESD source is applied to the connector pins. The test circuit for IEC1000-4-2 is shown on Figure 10. There are two methods within IEC1000-4-2, the Air Discharge method and the Contact Discharge method.

With the Air Discharge Method, an ESD voltage is applied to the equipment under test (EUT) through air. This simulates an electrically charged

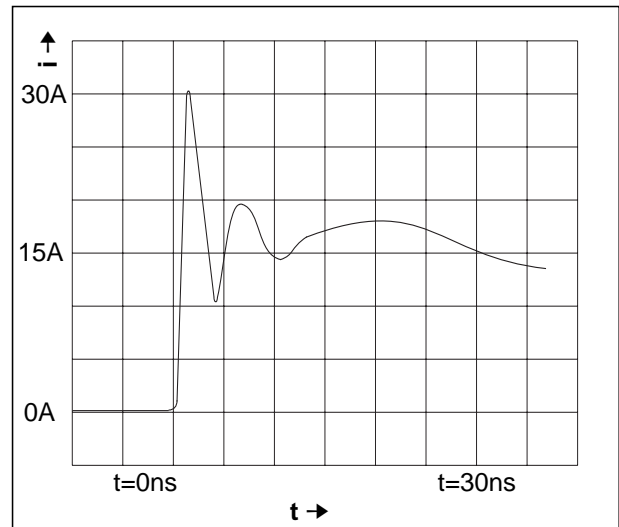

Figure 11. ESD Test Waveform for IEC1000-4-2



person ready to connect a cable onto the rear of the system only to find an unpleasant zap just before the person touches the back panel. The high energy potential on the person discharges through an arcing path to the rear panel of the system before he or she even touches the system. This energy, whether discharged directly or through air, is predominantly a function of the discharge current rather than the discharge voltage. Variables with an air discharge such as approach speed of the object carrying the ESD potential to the system and humidity will tend to change the discharge current. For example, the rise time of the discharge current varies with the approach speed.

The Contact Discharge Method applies the ESD current directly to the EUT. This method was devised to reduce the unpredictability of the ESD arc. The discharge current rise time is constant since the energy is directly transferred without the air-gap arc. In situations such as hand held systems, the ESD charge can be directly discharged to the equipment from a person already holding the equipment. The current is transferred on to the keypad or the serial port of the equipment directly and then travels through the PCB and finally to the IC.

The circuit models in *Figures 9 and 10* represent the typical ESD testing circuits used for all three methods. The  $C_s$  is initially charged with the DC power supply when the first switch (SW1) is on. Now that the capacitor is charged, the second switch (SW2) is on while SW1 switches off. The voltage stored in the capacitor is then applied through  $R_s$ , the current limiting resistor, onto the device under test (DUT). In ESD tests, the SW2 switch is pulsed so that the device under test receives a duration of voltage.

For the Human Body Model, the current limiting resistor ( $R_s$ ) and the source capacitor ( $C_s$ ) are  $1.5k\Omega$  and  $100pF$ , respectively. For IEC-1000-4-2, the current limiting resistor ( $R_s$ ) and the source capacitor ( $C_s$ ) are  $330\Omega$  and  $150pF$ , respectively.

The higher  $C_s$  value and lower  $R_s$  value in the IEC1000-4-2 model are more stringent than the Human Body Model. The larger storage capacitor injects a higher voltage to the test point when SW2 is switched on. The lower current limiting resistor increases the current charge onto the test point.

SP490E/SP491E Family	HUMAN BODY MODEL	IEC1000-4-2		
		Air Discharge	Direct Contact	Level
Driver Outputs	$\pm 15kV$	$\pm 15kV$	$\pm 8kV$	4
Receiver Inputs	$\pm 15kV$	$\pm 15kV$	$\pm 8kV$	4

*Table 1. Transceiver ESD Tolerance Levels*

# PACKAGE: PLASTIC DUAL-IN-LINE (NARROW)

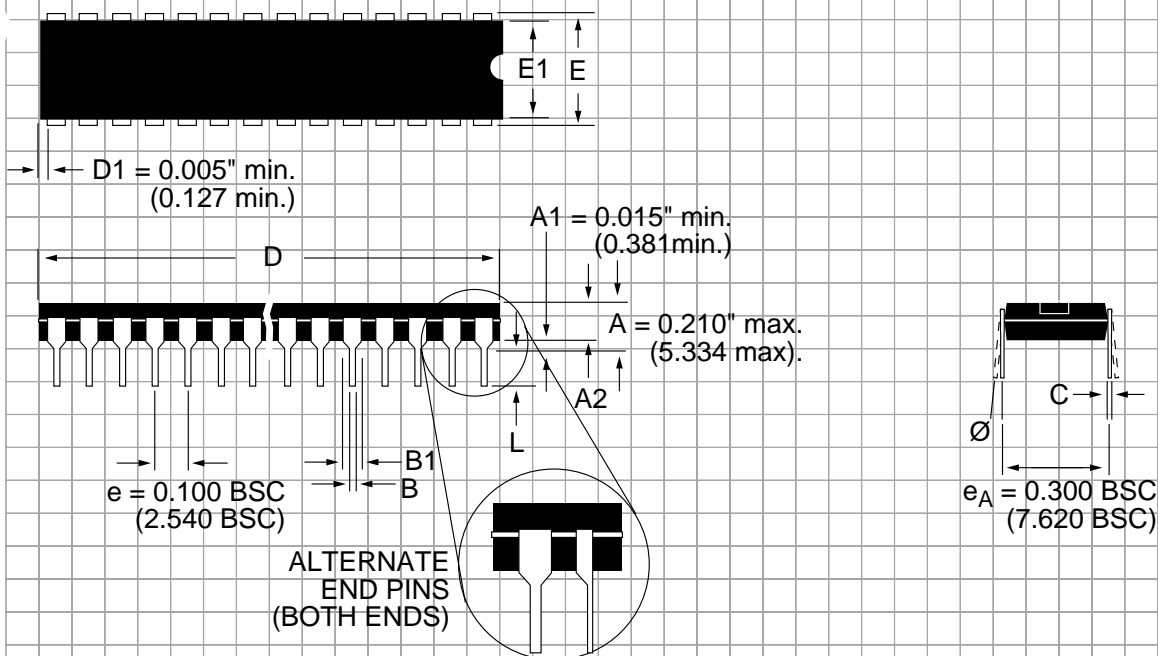

DIMENSIONS (Inches) Minimum/Maximum (mm)	8-PIN	14-PIN	16-PIN	18-PIN	20-PIN	22-PIN
A2	0.115/0.195 (2.921/4.953)	0.115/0.195 (2.921/4.953)	0.115/0.195 (2.921/4.953)	0.115/0.195 (2.921/4.953)	0.115/0.195 (2.921/4.953)	0.115/0.195 (2.921/4.953)
B	0.014/0.022 (0.356/0.559)	0.014/0.022 (0.356/0.559)	0.014/0.022 (0.356/0.559)	0.014/0.022 (0.356/0.559)	0.014/0.022 (0.356/0.559)	0.014/0.022 (0.356/0.559)
B1	0.045/0.070 (1.143/1.778)	0.045/0.070 (1.143/1.778)	0.045/0.070 (1.143/1.778)	0.045/0.070 (1.143/1.778)	0.045/0.070 (1.143/1.778)	0.045/0.070 (1.143/1.778)
C	0.008/0.014 (0.203/0.356)	0.008/0.014 (0.203/0.356)	0.008/0.014 (0.203/0.356)	0.008/0.014 (0.203/0.356)	0.008/0.014 (0.203/0.356)	0.008/0.014 (0.203/0.356)
D	0.355/0.400 (9.017/10.160)	0.735/0.775 (18.669/19.685)	0.780/0.800 (19.812/20.320)	0.880/0.920 (22.352/23.368)	0.980/1.060 (24.892/26.924)	1.145/1.155 (29.083/29.337)
E	0.300/0.325 (7.620/8.255)	0.300/0.325 (7.620/8.255)	0.300/0.325 (7.620/8.255)	0.300/0.325 (7.620/8.255)	0.300/0.325 (7.620/8.255)	0.300/0.325 (7.620/8.255)
E1	0.240/0.280 (6.096/7.112)	0.240/0.280 (6.096/7.112)	0.240/0.280 (6.096/7.112)	0.240/0.280 (6.096/7.112)	0.240/0.280 (6.096/7.112)	0.240/0.280 (6.096/7.112)
L	0.115/0.150 (2.921/3.810)	0.115/0.150 (2.921/3.810)	0.115/0.150 (2.921/3.810)	0.115/0.150 (2.921/3.810)	0.115/0.150 (2.921/3.810)	0.115/0.150 (2.921/3.810)
Ø	0°/ 15° (0°/15°)	0°/ 15° (0°/15°)	0°/ 15° (0°/15°)	0°/ 15° (0°/15°)	0°/ 15° (0°/15°)	0°/ 15° (0°/15°)

**PACKAGE: PLASTIC  
SMALL OUTLINE (SOIC)  
(NARROW)**

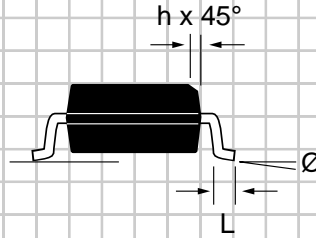
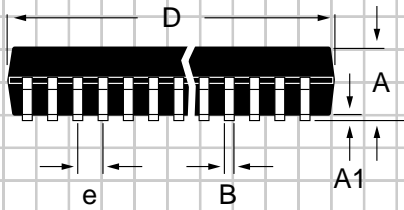
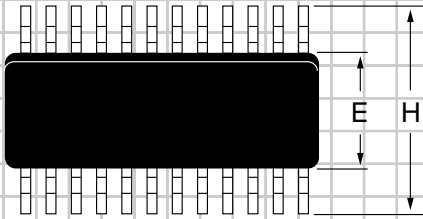

DIMENSIONS (Inches) Minimum/Maximum (mm)	8-PIN	14-PIN	16-PIN			
A	0.053/0.069 (1.346/1.748)	0.053/0.069 (1.346/1.748)	0.053/0.069 (1.346/1.748)			
A1	0.004/0.010 (0.102/0.249)	0.004/0.010 (0.102/0.249)	0.004/0.010 (0.102/0.249)			
B	0.014/0.019 (0.35/0.49)	0.013/0.020 (0.330/0.508)	0.013/0.020 (0.330/0.508)			
D	0.189/0.197 (4.80/5.00)	0.337/0.344 (8.552/8.748)	0.386/0.394 (9.802/10.000)			
E	0.150/0.157 (3.802/3.988)	0.150/0.157 (3.802/3.988)	0.150/0.157 (3.802/3.988)			
e	0.050 BSC (1.270 BSC)	0.050 BSC (1.270 BSC)	0.050 BSC (1.270 BSC)			
H	0.228/0.244 (5.801/6.198)	0.228/0.244 (5.801/6.198)	0.228/0.244 (5.801/6.198)			
h	0.010/0.020 (0.254/0.498)	0.010/0.020 (0.254/0.498)	0.010/0.020 (0.254/0.498)			
L	0.016/0.050 (0.406/1.270)	0.016/0.050 (0.406/1.270)	0.016/0.050 (0.406/1.270)			
Ø	0°/8° (0°/8°)	0°/8° (0°/8°)	0°/8° (0°/8°)			

## ORDERING INFORMATION

Model	Temperature Range	Package
SP490ECN .....	0°C to +70°C .....	8-Pin NSOIC
SP490ECP .....	0°C to +70°C .....	8-Pin DIP
SP490EEN .....	-40°C to +85°C .....	8-Pin NSOIC
SP490EEP .....	-40°C to +85°C .....	8-Pin DIP
SP491ECN .....	0°C to +70°C .....	14-Pin NSOIC
SP491ECP .....	0°C to +70°C .....	14-Pin DIP
SP491EEN .....	-40°C to +85°C .....	14-Pin NSOIC
SP491EEP .....	-40°C to +85°C .....	14-Pin DIP

Please consult the factory for pricing and availability on a Tape-On-Reel option.



SIGNAL PROCESSING EXCELLENCE

### Sipex Corporation

#### Headquarters and Sales Office

22 Linnell Circle  
Billerica, MA 01821  
TEL: (978) 667-8700  
FAX: (978) 670-9001  
e-mail: sales@sipex.com

#### Sales Office

233 South Hillview Drive  
Milpitas, CA 95035  
TEL: (408) 934-7500  
FAX: (408) 935-7600

Sipex Corporation reserves the right to make changes to any products described herein. Sipex does not assume any liability arising out of the application or use of any product or circuit described hereing; neither does it convey any license under its patent rights nor the rights of others.