

THYRISTOR MODULE

PK(PD,PE,KK)160F

UL:E76102(M)

Power Thyristor/Diode Module **PK160F** series are designed for various rectifier circuits and power controls. For your circuit application, following internal connections and wide voltage ratings up to 1,600V are available. Two elements in a package and electrically isolated mounting base make your mechanical design easy.

- $I_{T(AV)}$ 160A, $I_{T(RMS)}$ 250A, I_{TSM} 5500A
- di/dt 200 A/ μ s
- dv/dt 500V/ μ s

(Applications)

Various rectifiers
AC/DC motor drives
Heater controls
Light dimmers
Static switches

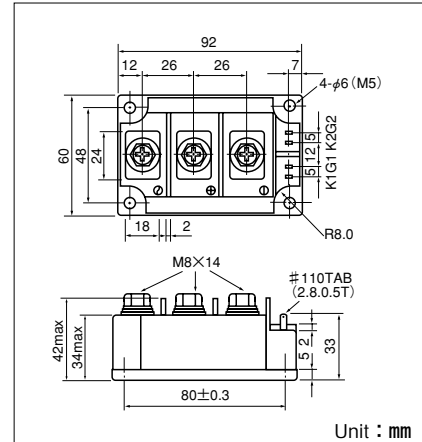
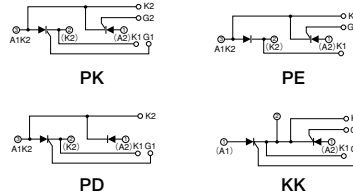

Maximum Ratings

Symbol	Item	Ratings				Unit
		PK160F40 PD160F40 PE160F40 KK160F40	PK160F80 PD160F80 PE160F80 KK160F80	PK160F120 PD160F120 PE160F120 KK160F120	PK160F160 PD160F160 PE160F160 KK160F160	
V_{RRM}	* Repetitive Peak Reverse Voltage	400	800	1200	1600	V
V_{RSM}	* Non-Repetitive Peak Reverse Voltage	480	960	1300	1700	V
V_{DRM}	Repetitive Peak Off-State Voltage	400	800	1200	1600	V

Symbol	Item	Conditions	Ratings	Unit
$I_{T(AV)}$, $I_{F(AV)}$	* Average On-State Current	Single phase, half wave, 180° conduction, $T_c : 87^\circ\text{C}$	160	A
$I_{T(RMS)}$, $I_{F(RMS)}$	* R.M.S. On-State Current	Single phase, half wave, 180° conduction, $T_c : 87^\circ\text{C}$	250	A
I_{TSM} , I_{FSM}	* Surge On-State Current	$\frac{1}{2}$ cycle, 50Hz/60Hz, peak Value, non-repetitive	5000/5500	A
I^2t	* I^2t	Value for one cycle of surge current	1.25×10^5	A ² S
PGM	Peak Gate Power Dissipation		10	W
PG(AV)	Average Gate Power Dissipation		3	W
IFGM	Peak Gate Current		3	A
VFGM	Peak Gate Voltage (Forward)		10	V
VRGM	Peak Gate Voltage (Reverse)		5	V
di/dt	Critical Rate of Rise of On-State Current	$I_G=100\text{mA}$, $T_j=25^\circ\text{C}$, $V_D=\frac{1}{2}V_{DRM}$, $dI_G/dt=0.1\text{A}/\mu\text{s}$	200	A/ μs
VISO	* Isolation Breakdown Voltage (R.M.S.)	A.C. 1 minute	2500	V
T_j	* Operating Junction Temperature		-40 to +125	$^\circ\text{C}$
T_{stg}	* Storage Temperature		-40 to +125	$^\circ\text{C}$
	Mounting Torque	Mounting (M5)	Recommended 1.5-2.5 (15-25)	N·m (kgf·cm)
		Terminal (M8)	Recommended 8.8-10 (90-105)	
	Mass		510	g

Electrical Characteristics

Symbol	Item	Conditions	Ratings	Unit
I_{DRM}	Repetitive Peak Off-State Current, max.	at V_{DRM} , single phase, half wave, $T_j=125^\circ\text{C}$	50	mA
I_{RRM}	* Repetitive Peak Reverse Current, max.	at V_{DRM} , single phase, half wave, $T_j=125^\circ\text{C}$	50	mA
V_{TM}	* Peak On-State Voltage, max.	On-State Current 500A, $T_j=25^\circ\text{C}$ Inst. measurement	1.42	V
I_{GT}/V_{GT}	Gate Trigger Current/Voltage, max.	$T_j=25^\circ\text{C}$, $I_T=1\text{A}$, $V_D=6\text{V}$	100/3	mA/V
V_{GD}	Non-Trigger Gate, Voltage, min.	$T_j=125^\circ\text{C}$, $V_D=\frac{1}{2}V_{DRM}$	0.25	V
tgt	Turn On Time, max.	$I_T=160\text{A}$, $I_G=100\text{mA}$, $T_j=25^\circ\text{C}$, $V_D=\frac{1}{2}V_{DRM}$, $dI_G/dt=0.1\text{A}/\mu\text{s}$	10	μs
dv/dt	Critical Rate of Rise of Off-State Voltage, min.	$T_j=125^\circ\text{C}$, $V_D=\frac{2}{3}V_{DRM}$, Exponential wave.	500	V/ μs
I_H	Holding Current, typ.	$T_j=25^\circ\text{C}$	50	mA
I_L	Latching Current, typ.	$T_j=25^\circ\text{C}$	100	mA
$R_{th(j-c)}$	* Thermal Impedance, max.	Junction to case	0.18	$^\circ\text{C}/\text{W}$

* mark : Thyristor and Diode part. No mark : Thyristor part

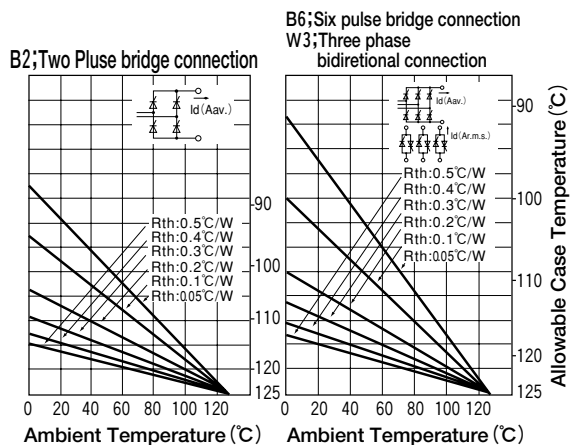
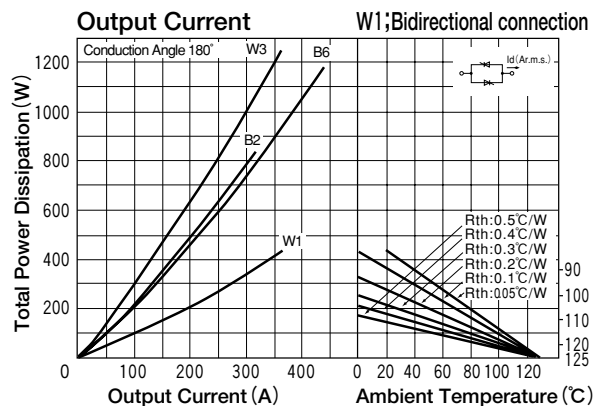
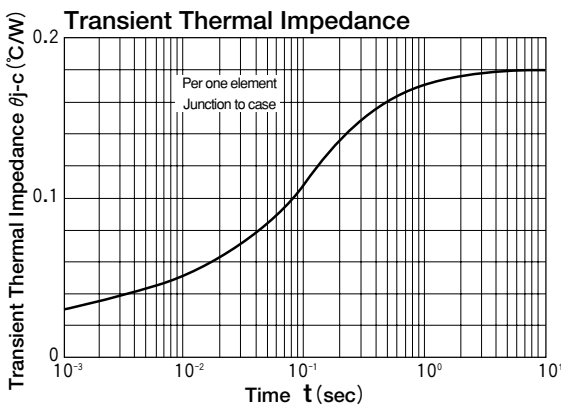
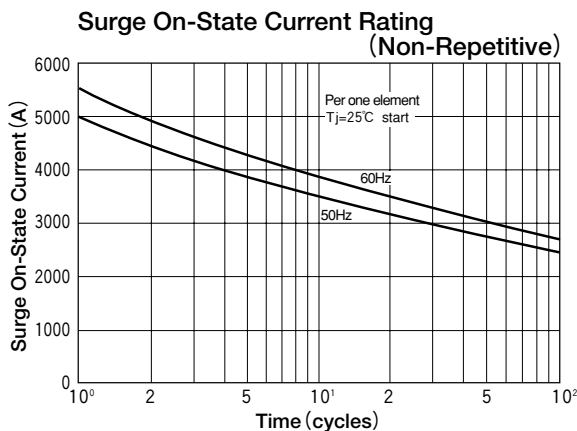
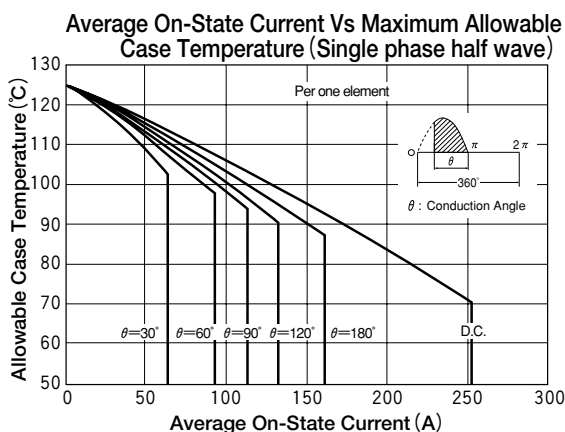
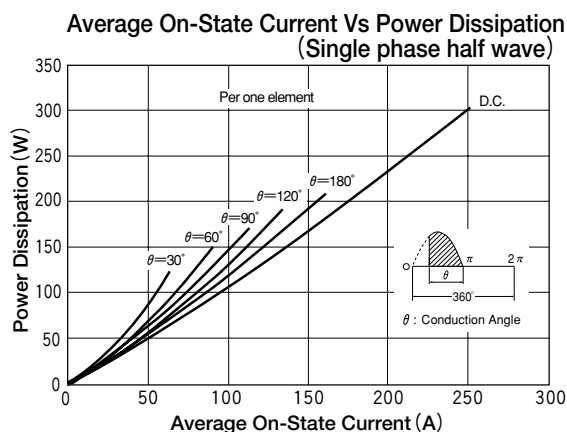
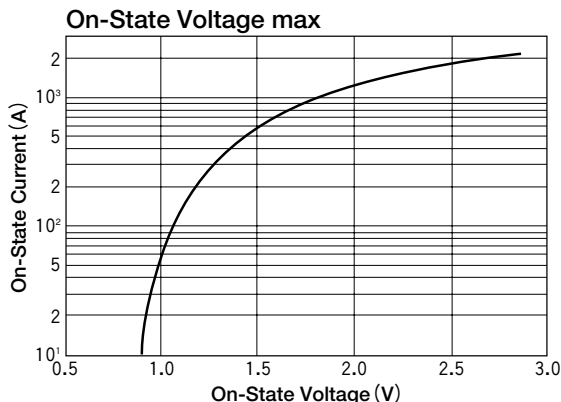
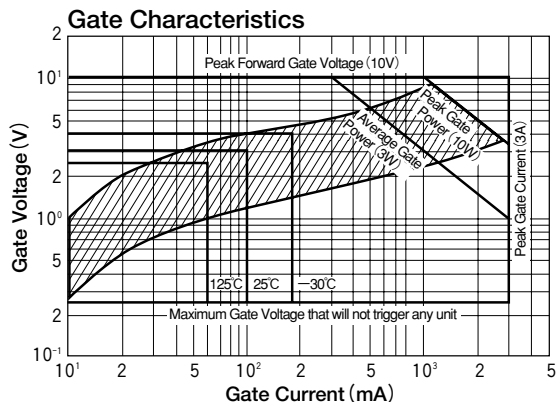

B6; Six pulse bridge connection
W3; Three phase bidirectional connection

