

ACT™ 2 Family FPGAs

Features

- Up to 8000 Gate Array Gates (20,000 PLD equivalent gates)
- Replaces up to 200 TTL Packages
- Replaces up to eighty 20-Pin PAL® Packages
- Design Library with over 500 Macro Functions
- Single-Module Sequential Functions
- Wide-Input Combinatorial Functions
- Up to 1232 Programmable Logic Modules
- Up to 998 Flip-Flops
- Datapath Performance at 105 MHz
- 16-Bit Accumulator Performance to 39 MHz
- Two In-Circuit Diagnostic Probe Pins Support Speed Analysis to 50 MHz
- Two High-Speed, Low-Skew Clock Networks
- I/O Drive to 10 mA
- Nonvolatile, User Programmable
- Logic Fully Tested Prior to Shipment
- 1.0-micron CMOS Technology

Product Family Profile

Device	A1225A	A1240A	A1280A
Capacity			
Gate Array Equivalent Gates	2,500	4,000	8,000
PLD Equivalent Gates	6,250	10,000	20,000
TTL Equivalent Packages	63	100	200
20-Pin PAL Equivalent Packages	25	40	80
Logic Modules	451	684	1,232
S-Modules	231	348	624
C-Modules	220	336	608
Flip-Flops (maximum)	382	568	998
Routing Resources			
Horizontal Tracks/Channel	36	36	36
Vertical Tracks/Channel	15	15	15
PLICE Antifuse Elements	250,000	400,000	750,000
User I/Os (maximum)	83	104	140
Packages ¹	100 CPGA 100 PQFP 100 VQFP 84 PLCC	132 CPGA 144 PQFP 176 TQFP 84 PLCC	176 CPGA 160 PQFP 176 TQFP 84 PLCC 172 CQFP
Performance ²			
16-Bit Prescaled Counters	105 MHz	100 MHz	85 MHz
16-Bit Loadable Counters	70 MHz	69 MHz	67 MHz
16-Bit Accumulators	39 MHz	38 MHz	36 MHz

Notes:

1. See the "Product Plan" on page 3 for package availability.
2. Performance is based on '-2' speed devices at commercial worst-case operating conditions using PREP Benchmarks, Suite #1, Version 1.2, dated 3-28-93, any analysis is not endorsed by PREP.

Description

The ACT™ 2 family represents Actel's second generation of field programmable gate arrays (FPGAs). The ACT 2 family presents a two-module architecture, consisting of C-modules and S-modules. These modules are optimized for both combinatorial and sequential designs. Based on Actel's patented channeled array architecture, the ACT 2 family provides significant enhancements to gate density and performance while maintaining downward compatibility with the ACT 1 design environment and upward compatibility with the ACT 3 design environment. The devices are implemented in silicon gate, 1.0- μ m, two-level metal CMOS, and employ Actel's PLICE® antifuse

technology. This revolutionary architecture offers gate array design flexibility, high performance, and fast

time-to-production with user programming. The ACT 2 family is supported by the Designer and Designer Advantage Systems, which offers automatic pin assignment, validation of electrical and design rules, automatic placement and routing, timing analysis, user programming, and diagnostic probe capabilities. The systems are supported on the following platforms: 386/486™ PC, Sun™, and HP™ workstations. The systems provide CAE interfaces to the following design environments: Cadence, Viewlogic®, Mentor Graphics®, and OrCAD™.

Ordering Information

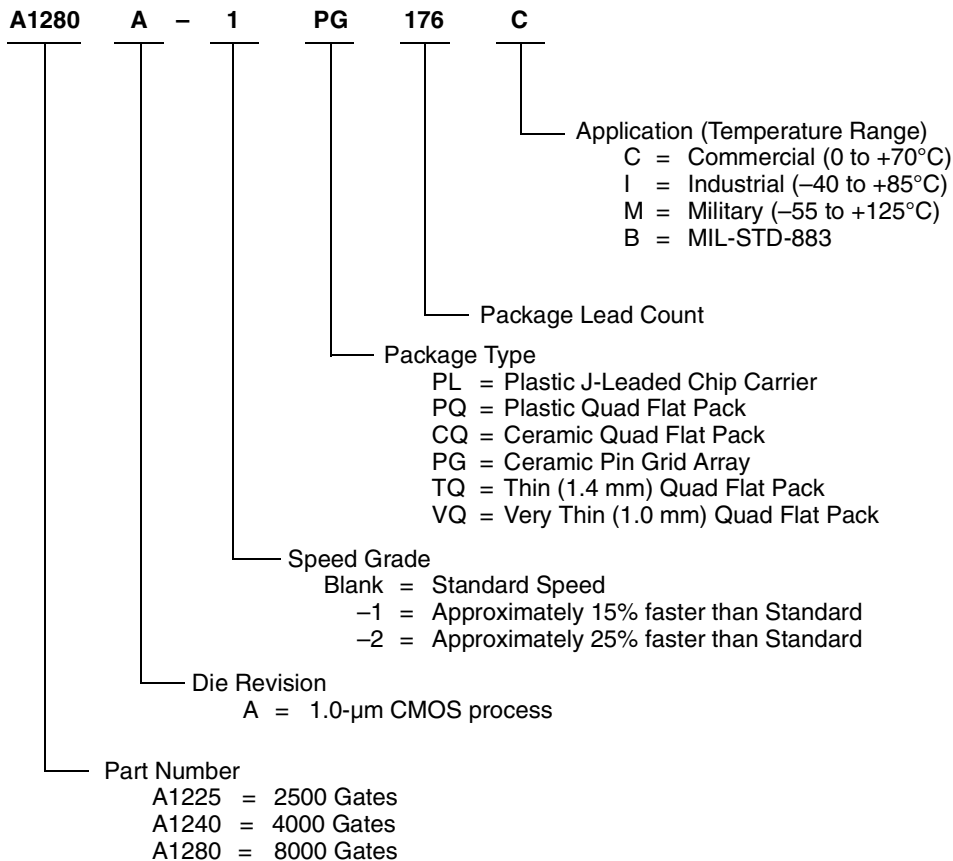

Operating Conditions

Absolute Maximum Ratings¹

Free air temperature range

Symbol	Parameter	Limits	Units
V _{CC}	DC Supply Voltage	-0.5 to +7.0	V
V _I	Input Voltage	-0.5 to V _{CC} + 0.5	V
V _O	Output Voltage	-0.5 to V _{CC} + 0.5	V
I _{IO}	I/O Source/Sink Current ²	±20	mA
T _{STG}	Storage Temperature	-65 to +150	°C

Notes:

- Stresses beyond those listed under “Absolute Maximum Ratings” may cause permanent damage to the device. Exposure to absolute maximum rated conditions for extended periods may affect device reliability. Device should not be operated outside the Recommended Operating Conditions.
- Device inputs are normally high impedance and draw extremely low current. However, when input voltage is greater than V_{CC} + 0.5 V or less than GND - 0.5 V, the internal protection diode will be forward biased and can draw excessive current.

Recommended Operating Conditions

Parameter	Commercial	Industrial	Military	Units
Temperature Range ¹	0 to +70	-40 to +85	-55 to +125	°C
Power Supply Tolerance	±5	±10	±10	%V _{CC}

Note:

- Ambient temperature (T_A) is used for commercial and industrial; case temperature (T_C) is used for military.

Electrical Specifications

Symbol	Parameter	Commercial		Industrial		Military		Units
		Min.	Max.	Min.	Max.	Min.	Max.	
V _{OH} ¹	(I _{OH} = -10 mA) ²	2.4						V
	(I _{OH} = -6 mA)	3.84						V
	(I _{OH} = -4 mA)			3.7		3.7		V
V _{OL} ¹	(I _{OL} = 10 mA) ²		0.5					V
	(I _{OL} = 6 mA)		0.33		0.40		0.40	V
V _{IL}		-0.3	0.8	-0.3	0.8	-0.3	0.8	V
V _{IH}		2.0	V _{CC} + 0.3	2.0	V _{CC} + 0.3	2.0	V _{CC} + 0.3	V
Input Transition Time t _R , t _F ²			500		500		500	ns
C _{IO} I/O Capacitance ^{2, 3}			10		10		10	pF
Standby Current, I _{CC} ⁴ (typical = 1 mA)			2		10		20	mA
Leakage Current ⁵		-10	10	-10	10	-10	10	µA

Notes:

- Only one output tested at a time. V_{CC} = min.
- Not tested, for information only.
- Includes worst-case 176 CPGA package capacitance. V_{OUT} = 0 V, f = 1 MHz.
- All outputs unloaded. All inputs = V_{CC} or GND, typical I_{CC} = 1 mA. I_{CC} limit includes I_{PP} and I_{SV} during normal operation.
- V_{OUT}, V_{IN} = V_{CC} or GND.

Package Thermal Characteristics

The device junction to case thermal characteristic is θ_{jc} , and the junction to ambient air characteristic is θ_{ja} . The thermal characteristics for θ_{ja} are shown with two different air flow rates.

Maximum junction temperature is 150°C.

A sample calculation of the absolute maximum power dissipation allowed for a PQFP 160-pin package at commercial temperature is as follows:

$$\frac{\text{Max. junction temp. (°C)} - \text{Max. commercial temp.}}{\theta_{ja} \text{ (°C/W)}} = \frac{150^\circ\text{C} - 70^\circ\text{C}}{33^\circ\text{C/W}} = 2.4 \text{ W}$$

Package Type	Pin Count	θ_{jc}	θ_{ja} Still Air	θ_{ja} 300 ft/min	Units
Ceramic Pin Grid Array	100	5	35	17	°C/W
	132	5	30	15	°C/W
	176	8	23	12	°C/W
Ceramic Quad Flat Pack	172	8	25	15	°C/W
Plastic Quad Flat Pack ¹	100	13	48	40	°C/W
	144	15	40	32	°C/W
	160	15	38	30	°C/W
Plastic Leaded Chip Carrier ²	84	12	37	28	°C/W
Very Thin Quad Flat Pack ³	100	12	43	35	°C/W
Thin Quad Flat Pack ⁴	176	15	32	25	°C/W

Notes: (Maximum Power in Still Air)

1. Maximum Power Dissipation for PQFP packages are 1.9 Watts (100-pin), 2.3 Watts (144-pin), and 2.4 Watts (160-pin).
2. Maximum Power Dissipation for PLCC packages is 2.7 Watts.
3. Maximum Power Dissipation for VQFP packages is 2.3 Watts.
4. Maximum Power Dissipation for TQFP packages is 3.1 Watts.

Power Dissipation

$$P = [I_{CC\text{standby}} + I_{CC\text{active}}] * V_{CC} + I_{OL} * V_{OL} * N + I_{OH} * (V_{CC} - V_{OH}) * M$$

Where:

I_{CC} standby is the current flowing when no inputs or outputs are changing.

I_{CC} active is the current flowing due to CMOS switching.

I_{OL} , I_{OH} are TTL sink/source currents.

V_{OL} , V_{OH} are TTL level output voltages.

N equals the number of outputs driving TTL loads to V_{OL} .

M equals the number of outputs driving TTL loads to V_{OH} .

An accurate determination of N and M is problematical because their values depend on the family type, design details, and on the system I/O. The power can be divided into two components: static and active.

Static Power Component

Actel FPGAs have small static power components that result in lower power dissipation than PALs or PLDs. By integrating multiple PALs/PLDs into one FPGA, an even

greater reduction in board-level power dissipation can be achieved.

The power due to standby current is typically a small component of the overall power. Standby power is calculated below for commercial, worst case conditions.

I_{CC}	V_{CC}	Power
2 mA	5.25V	10.5 mW

The static power dissipated by TTL loads depends on the number of outputs driving high or low and the DC load current. Again, this value is typically small. For instance, a 32-bit bus sinking 4 mA at 0.33 V will generate 42 mW with all outputs driving low, and 140 mW with all outputs driving high. The actual dissipation will average somewhere between as I/Os switch states with time.

Active Power Component

Power dissipation in CMOS devices is usually dominated by the active (dynamic) power dissipation. This component is frequency dependent, a function of the logic and the external I/O. Active power dissipation results from charging internal chip capacitances of the interconnect, unprogrammed antifuses, module inputs, and module outputs, plus external capacitance due to PC board traces

and load device inputs. An additional component of the active power dissipation is the totem-pole current in CMOS transistor pairs. The net effect can be associated with an equivalent capacitance that can be combined with frequency and voltage to represent active power dissipation.

Equivalent Capacitance

The power dissipated by a CMOS circuit can be expressed by the Equation 1.

$$\text{Power } (\mu\text{W}) = C_{\text{EQ}} * V_{\text{CC}}^2 * F \quad (1)$$

Where:

C_{EQ} is the equivalent capacitance expressed in pF.

V_{CC} is the power supply in volts.

F is the switching frequency in MHz.

Equivalent capacitance is calculated by measuring ICC active at a specified frequency and voltage for each circuit component of interest. Measurements have been made over a range of frequencies at a fixed value of VCC. Equivalent capacitance is frequency independent so that the results may be used over a wide range of operating conditions. Equivalent capacitance values are shown below.

C_{EQ} Values for Actel FPGAs

Modules (C_{EQM})	5.8
Input Buffers (C_{EQI})	12.9
Output Buffers (C_{EQO})	23.8
Routed Array Clock Buffer Loads (C_{EQCR})	3.9

To calculate the active power dissipated from the complete design, the switching frequency of each part of the logic must be known. Equation 2 shows a piece-wise linear summation over all components.

$$\begin{aligned} \text{Power} = & V_{\text{CC}}^2 * [(m * C_{\text{EQM}} * f_m)_{\text{modules}} + (n * C_{\text{EQI}} * f_n)_{\text{inputs}} \\ & + (p * (C_{\text{EQO}} + C_L) * f_p)_{\text{outputs}} + 0.5 * (q_1 * C_{\text{EQCR}} * \\ & f_{q1})_{\text{routed_Clk1}} + (r_1 * f_{q1})_{\text{routed_Clk1}} + 0.5 * (q_2 * C_{\text{EQCR}} * \\ & f_{q2})_{\text{routed_Clk2}} \\ & + (r_2 * f_{q2})_{\text{routed_Clk2}}] \end{aligned} \quad (2)$$

Where:

- m = Number of logic modules switching at f_m
- n = Number of input buffers switching at f_n
- p = Number of output buffers switching at f_p
- q_1 = Number of clock loads on the first routed array clock
- q_2 = Number of clock loads on the second routed array clock
- r_1 = Fixed capacitance due to first routed array clock

- r_2 = Fixed capacitance due to second routed array clock
- C_{EQM} = Equivalent capacitance of logic modules in pF
- C_{EQI} = Equivalent capacitance of input buffers in pF
- C_{EQO} = Equivalent capacitance of output buffers in pF
- C_{EQCR} = Equivalent capacitance of routed array clock in pF
- C_L = Output lead capacitance in pF
- f_m = Average logic module switching rate in MHz
- f_n = Average input buffer switching rate in MHz
- f_p = Average output buffer switching rate in MHz
- f_{q1} = Average first routed array clock rate in MHz
- f_{q2} = Average second routed array clock rate in MHz

Fixed Capacitance Values for Actel FPGAs (pF)

Device Type	r_1 routed_Clk1	r_2 routed_Clk2
A1225A	106	106.0
A1240A	134	134.2
A1280A	168	167.8

Determining Average Switching Frequency

To determine the switching frequency for a design, you must have a detailed understanding of the data input values to the circuit. The following guidelines are meant to represent worst-case scenarios so that they can be generally used to predict the upper limits of power dissipation. These guidelines are as follows:

Logic Modules (m)	80% of modules
Inputs switching (n)	# inputs/4
Outputs switching (p)	# outputs/4
First routed array clock loads (q_1)	40% of sequential modules
Second routed array clock loads (q_2)	40% of sequential modules
Load capacitance (C_L)	35 pF
Average logic module switching rate (f_m)	F/10
Average input switching rate (f_n)	F/5
Average output switching rate (f_p)	F/10
Average first routed array clock rate (f_{q1})	F
Average second routed array clock rate (f_{q2})	F/2

ACT 2 Timing Model*

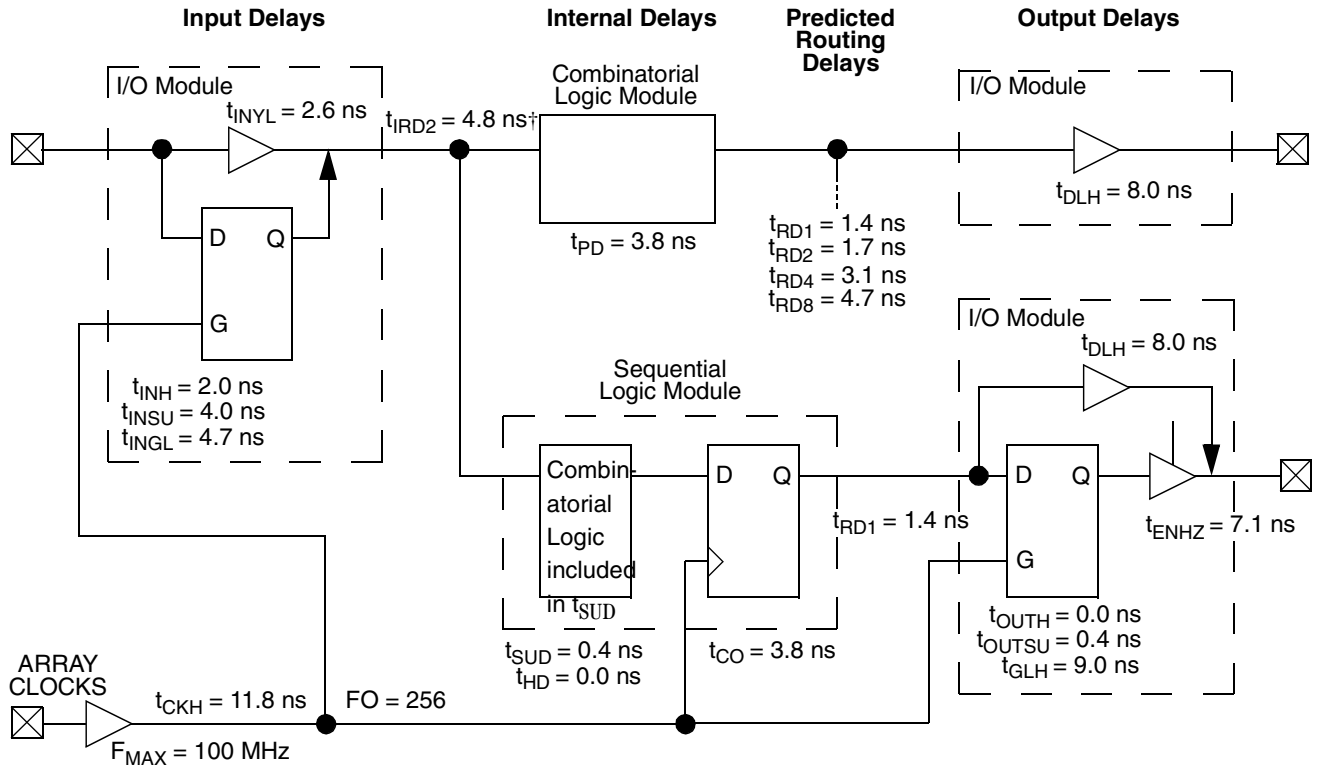

*Values shown for A1240A-2 at worst-case commercial conditions.

[†] Input Module Predicted Routing Delay

Parameter Measurement

Output Buffer Delays

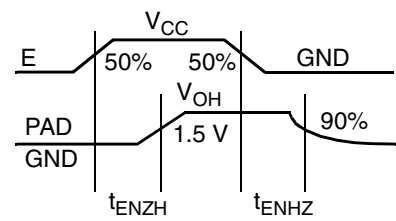
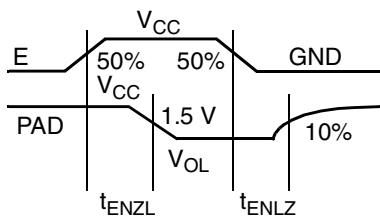
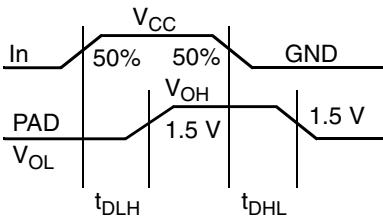

AC Test Loads

Load 1
(Used to measure propagation delay)

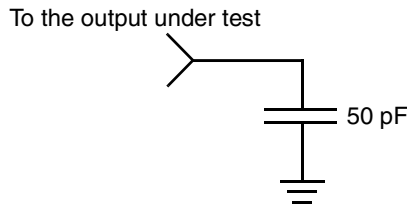

Load 2
(Used to measure rising/falling edges)

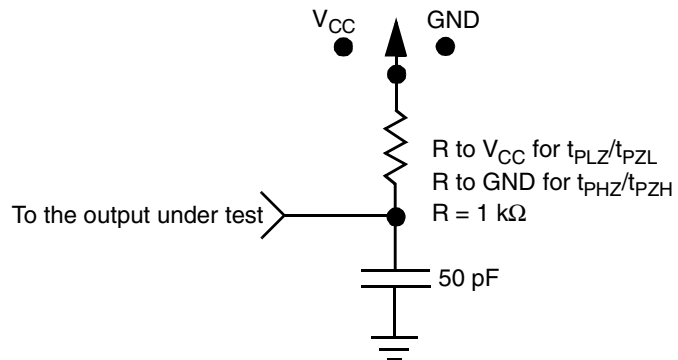

Input Buffer Delays

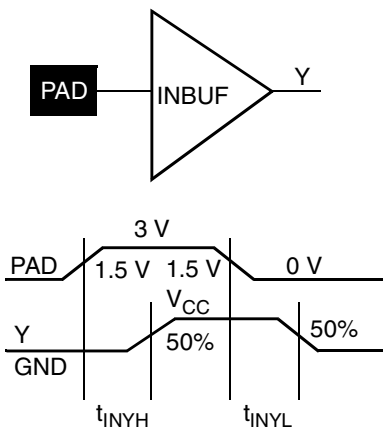

Module Delays

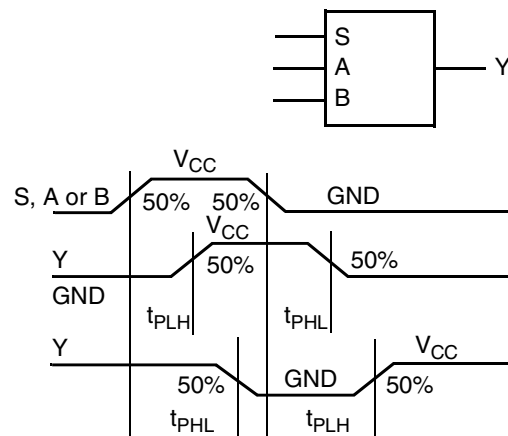

Sequential Module Timing Characteristics

Flip-Flops and Latches

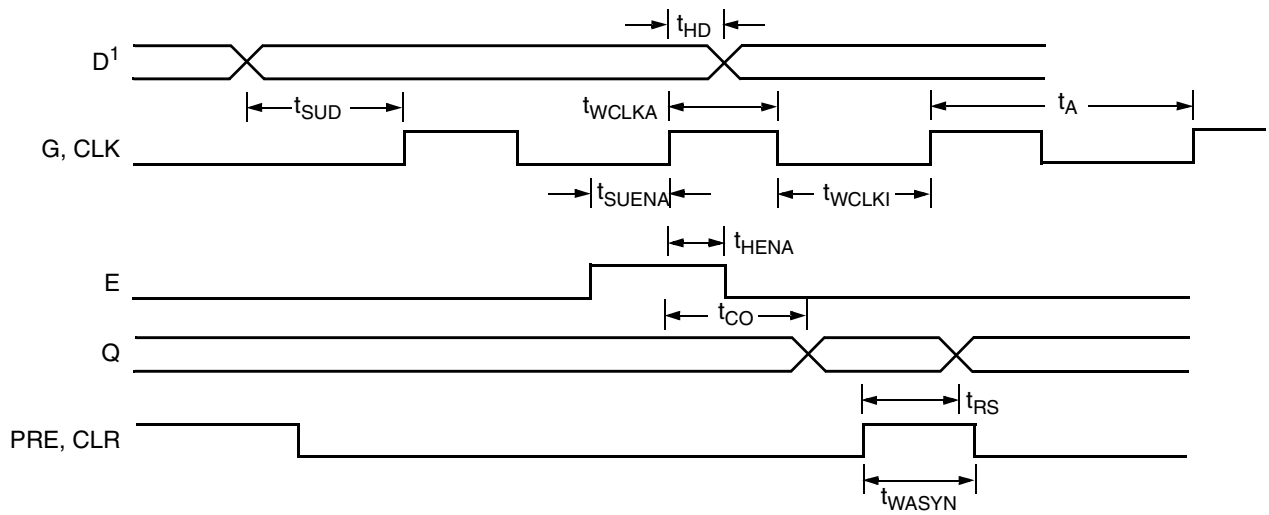
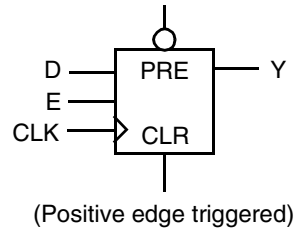

Note: D represents all data functions involving A , B , and S for multiplexed flip-flops.

Sequential Timing Characteristics (continued)

Input Buffer Latches

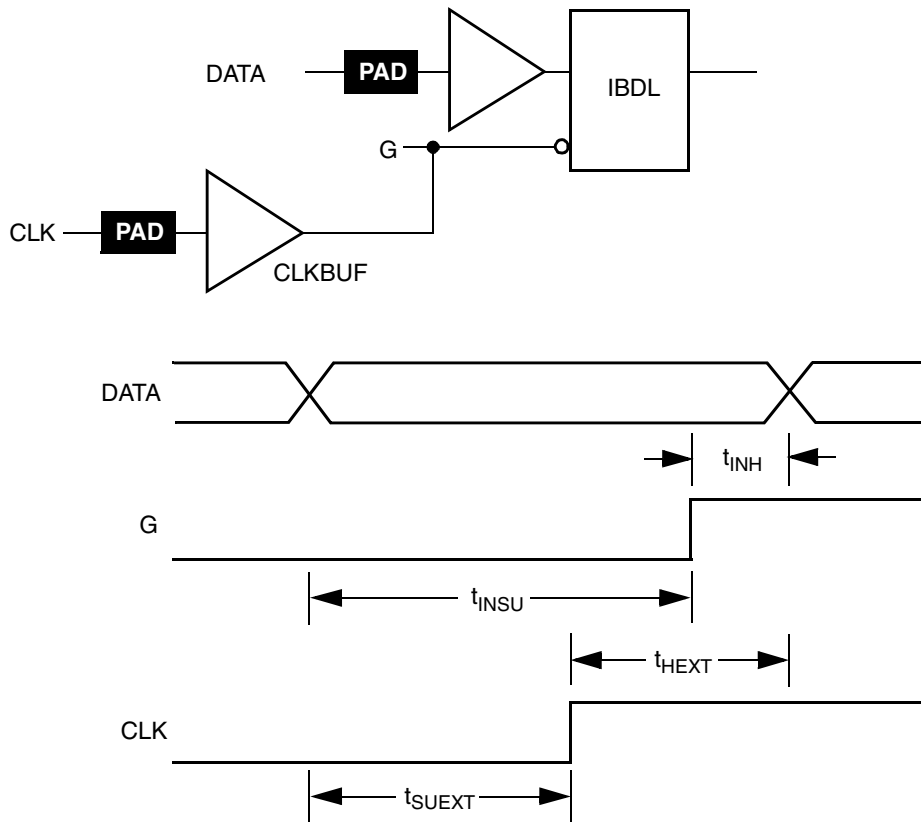

Output Buffer Latches

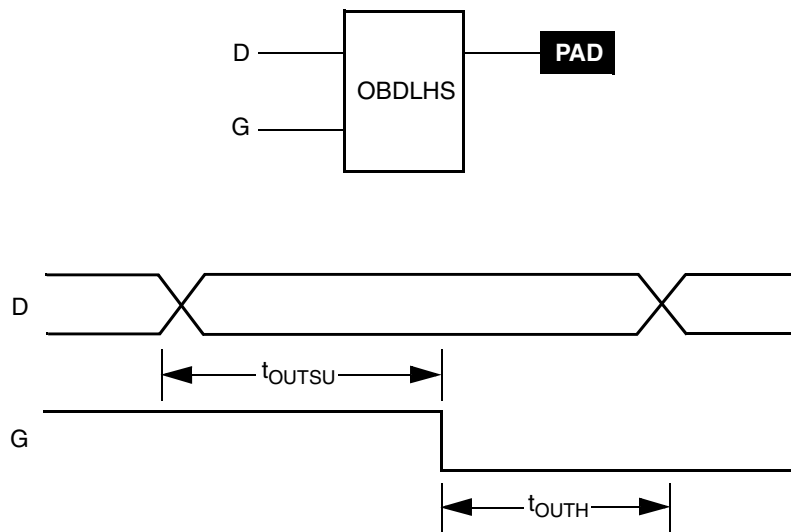

Timing Derating Factor (Temperature and Voltage)

	Industrial		Military	
	Min.	Max.	Min.	Max.
(Commercial Minimum/Maximum Specification) x	0.69	1.11	0.67	1.23

Timing Derating Factor for Designs at Typical Temperature ($T_J = 25^\circ\text{C}$) and Voltage (5.0 V)

(Commercial Maximum Specification) x	0.85
--------------------------------------	------

Temperature and Voltage Derating Factors (normalized to Worst-Case Commercial, $T_J = 4.75\text{ V}, 70^\circ\text{C}$)

	-55	-40	0	25	70	85	125
4.50	0.75	0.79	0.86	0.92	1.06	1.11	1.23
4.75	0.71	0.75	0.82	0.87	1.00	1.05	1.16
5.00	0.69	0.72	0.80	0.85	0.97	1.02	1.13
5.25	0.68	0.69	0.77	0.82	0.95	0.98	1.09
5.50	0.67	0.69	0.76	0.81	0.93	0.97	1.08

Junction Temperature and Voltage Derating Curves (normalized to Worst-Case Commercial, $T_J = 4.75\text{V}, 70^\circ\text{C}$)

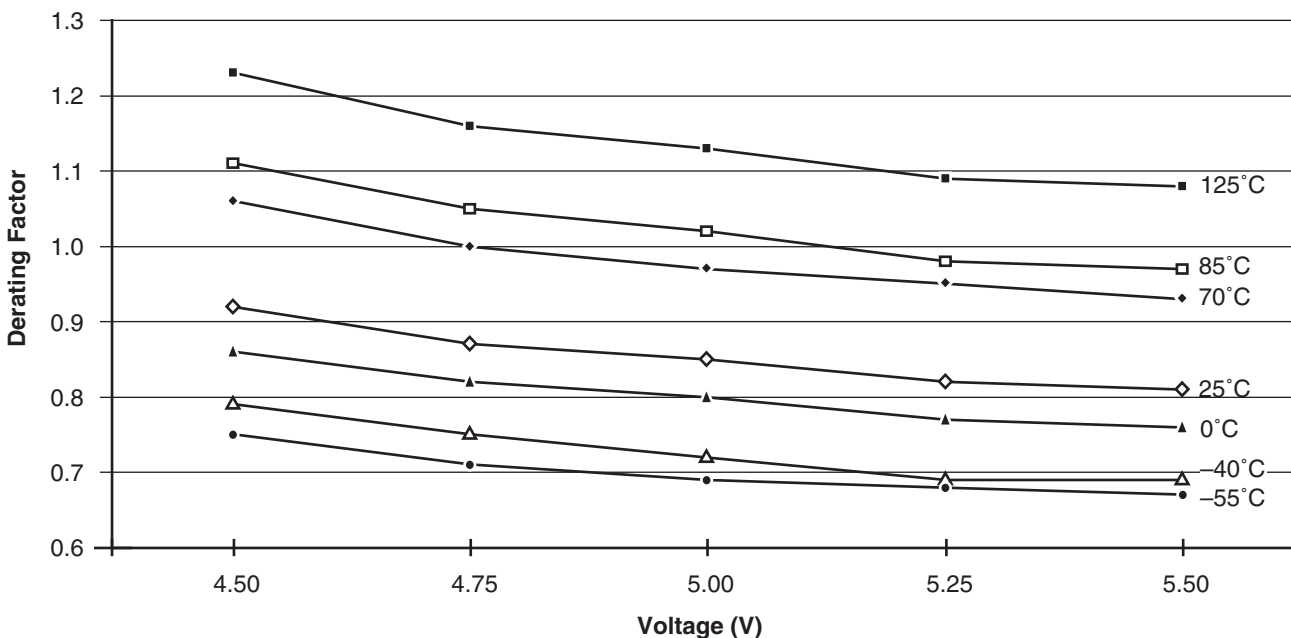

Note: This derating factor applies to all routing and propagation delays.

A1225A Timing Characteristics

(Worst-Case Commercial Conditions, $V_{CC} = 4.75\text{ V}$, $T_J = 70^\circ\text{C}$)

Logic Module Propagation Delays ¹		‘-2’ Speed		‘-1’ Speed		‘Std’ Speed		
Parameter	Description	Min.	Max.	Min.	Max.	Min.	Max.	Units
t_{PD1}	Single Module		3.8		4.3		5.0	ns
t_{CO}	Sequential Clk to Q		3.8		4.3		5.0	ns
t_{G0}	Latch G to Q		3.8		4.3		5.0	ns
t_{RS}	Flip-Flop (Latch) Reset to Q		3.8		4.3		5.0	ns
Predicted Routing Delays ²								
t_{RD1}	FO=1 Routing Delay		1.1		1.2		1.4	ns
t_{RD2}	FO=2 Routing Delay		1.7		1.9		2.2	ns
t_{RD3}	FO=3 Routing Delay		2.3		2.6		3.0	ns
t_{RD4}	FO=4 Routing Delay		2.8		3.1		3.7	ns
t_{RD8}	FO=8 Routing Delay		4.4		4.9		5.8	ns
Sequential Timing Characteristics ^{3,4}								
t_{SUD}	Flip-Flop (Latch) Data Input Setup	0.4		0.4		0.5		ns
t_{HD}	Flip-Flop (Latch) Data Input Hold	0.0		0.0		0.0		ns
t_{SUENA}	Flip-Flop (Latch) Enable Setup	0.8		0.9		1.0		ns
t_{HENA}	Flip-Flop (Latch) Enable Hold	0.0		0.0		0.0		ns
t_{WCLKA}	Flip-Flop (Latch) Clock Active Pulse Width	4.5		5.0		6.0		ns
t_{WASYN}	Flip-Flop (Latch) Asynchronous Pulse Width	4.5		5.0		6.0		ns
t_A	Flip-Flop Clock Input Period	9.4		11.0		13.0		ns
t_{INH}	Input Buffer Latch Hold	0.0		0.0		0.0		ns
t_{INSU}	Input Buffer Latch Setup	0.4		0.4		0.5		ns
t_{OUTH}	Output Buffer Latch Hold	0.0		0.0		0.0		ns
t_{OUTSU}	Output Buffer Latch Setup	0.4		0.4		0.5		ns
f_{MAX}	Flip-Flop (Latch) Clock Frequency		105.0		90.0		75.0	MHz

Notes:

- For dual-module macros, use $t_{PD1} + t_{RD1} + t_{PDn}$, $t_{CO} + t_{RD1} + t_{PDn}$ or $t_{PD1} + t_{RD1} + t_{SUD}$, whichever is appropriate.
- Routing delays are for typical designs across worst-case operating conditions. These parameters should be used for estimating device performance. Post-route timing analysis or simulation is required to determine actual worst-case performance. Post-route timing is based on actual routing delay measurements performed on the device prior to shipment.
- Data applies to macros based on the S-module. Timing parameters for sequential macros constructed from C-modules can be obtained from the DirectTime Analyzer utility.
- Setup and hold timing parameters for the Input Buffer Latch are defined with respect to the PAD and the D input. External setup/hold timing parameters must account for delay from an external PAD signal to the G inputs. Delay from an external PAD signal to the G input subtracts (adds) to the internal setup (hold) time.

A1225A Timing Characteristics (continued)**(Worst-Case Commercial Conditions)**

Input Module Propagation Delays			‘-2’ Speed		‘-1’ Speed		‘Std’ Speed		Unit s
Parameter	Description		Min.	Max.	Min.	Max.	Min.	Max.	
t _{INYH}	Pad to Y High			2.9		3.3		3.8	ns
t _{INYL}	Pad to Y Low			2.6		3.0		3.5	ns
t _{INGH}	G to Y High			5.0		5.7		6.6	ns
t _{INGL}	G to Y Low			4.7		5.4		6.3	ns
Input Module Predicted Routing Delays ¹									
t _{IRD1}	FO=1 Routing Delay			4.1		4.6		5.4	ns
t _{IRD2}	FO=2 Routing Delay			4.6		5.2		6.1	ns
t _{IRD3}	FO=3 Routing Delay			5.3		6.0		7.1	ns
t _{IRD4}	FO=4 Routing Delay			5.7		6.4		7.6	ns
t _{IRD8}	FO=8 Routing Delay			7.4		8.3		9.8	ns
Global Clock Network									
t _{CKH}	Input Low to High	FO = 32 FO = 256		10.2 11.8		11.0 13.0		12.8 15.7	ns
t _{CKL}	Input High to Low	FO = 32 FO = 256		10.2 12.0		11.0 13.2		12.8 15.9	ns
t _{PWH}	Minimum Pulse Width High	FO = 32 FO = 256	3.4 3.8		4.1 4.5		4.5 5.0		ns
t _{PWL}	Minimum Pulse Width Low	FO = 32 FO = 256	3.4 3.8		4.1 4.5		4.5 5.0		ns
t _{CKSW}	Maximum Skew	FO = 32 FO = 256		0.7 3.5		0.7 3.5		0.7 3.5	ns
t _{SUEXT}	Input Latch External Setup	FO = 32 FO = 256	0.0 0.0		0.0 0.0		0.0 0.0		ns
t _{HEXT}	Input Latch External Hold	FO = 32 FO = 256	7.0 11.2		7.0 11.2		7.0 11.2		ns
t _P	Minimum Period	FO = 32 FO = 256	7.7 8.1		8.3 8.8		9.1 10.0		ns
f _{MAX}	Maximum Frequency	FO = 32 FO = 256		130.0 125.0		120.0 115.0		110.0 100.0	MHz

Note:

- These parameters should be used for estimating device performance. Optimization techniques may further reduce delays by 0 to 4 ns. Routing delays are for typical designs across worst-case operating conditions. Post-route timing analysis or simulation is required to determine actual worst-case performance. Post-route timing is based on actual routing delay measurements performed on the device prior to shipment.

A1225A Timing Characteristics (continued)
(Worst-Case Commercial Conditions)

Output Module Timing		‘-2’ Speed		‘-1’ Speed		‘Std’ Speed		
Parameter	Description	Min.	Max.	Min.	Max.	Min.	Max.	Units
TTL Output Module Timing¹								
t _{DLH}	Data to Pad High		8.0		9.0		10.6	ns
t _{DHL}	Data to Pad Low		10.1		11.4		13.4	ns
t _{ENZH}	Enable Pad Z to High		8.9		10.0		11.8	ns
t _{ENZL}	Enable Pad Z to Low		11.6		13.2		15.5	ns
t _{ENHZ}	Enable Pad High to Z		7.1		8.0		9.4	ns
t _{ENLZ}	Enable Pad Low to Z		8.3		9.5		11.1	ns
t _{GLH}	G to Pad High		8.9		10.2		11.9	ns
t _{GHL}	G to Pad Low		11.2		12.7		14.9	ns
d _{TLH}	Delta Low to High		0.07		0.08		0.09	ns/pF
d _{THL}	Delta High to Low		0.12		0.13		0.16	ns/pF
CMOS Output Module Timing¹								
t _{DLH}	Data to Pad High		10.1		11.5		13.5	ns
t _{DHL}	Data to Pad Low		8.4		9.6		11.2	ns
t _{ENZH}	Enable Pad Z to High		8.9		10.0		11.8	ns
t _{ENZL}	Enable Pad Z to Low		11.6		13.2		15.5	ns
t _{ENHZ}	Enable Pad High to Z		7.1		8.0		9.4	ns
t _{ENLZ}	Enable Pad Low to Z		8.3		9.5		11.1	ns
t _{GLH}	G to Pad High		8.9		10.2		11.9	ns
t _{GHL}	G to Pad Low		11.2		12.7		14.9	ns
d _{TLH}	Delta Low to High		0.12		0.13		0.16	ns/pF
d _{THL}	Delta High to Low		0.09		0.10		0.12	ns/pF

Note:

1. Delays based on 50 pF loading.
2. SSO information can be found at http://www.actel.com/support/appnotes/appnotes_design.html#board.

A1240A Timing Characteristics**(Worst-Case Commercial Conditions, $V_{CC} = 4.75\text{ V}$, $T_J = 70^\circ\text{C}$)**

Logic Module Propagation Delays ¹		‘-2’ Speed		‘-1’ Speed		‘Std’ Speed		
Parameter	Description	Min.	Max.	Min.	Max.	Min.	Max.	Units
t_{PD1}	Single Module		3.8		4.3		5.0	ns
t_{CO}	Sequential Clk to Q		3.8		4.3		5.0	ns
t_{GO}	Latch G to Q		3.8		4.3		5.0	ns
t_{RS}	Flip-Flop (Latch) Reset to Q		3.8		4.3		5.0	ns
Predicted Routing Delays ²								
t_{RD1}	FO=1 Routing Delay		1.4		1.5		1.8	ns
t_{RD2}	FO=2 Routing Delay		1.7		2.0		2.3	ns
t_{RD3}	FO=3 Routing Delay		2.3		2.6		3.0	ns
t_{RD4}	FO=4 Routing Delay		3.1		3.5		4.1	ns
t_{RD8}	FO=8 Routing Delay		4.7		5.4		6.3	ns
Sequential Timing Characteristics ^{3, 4}								
t_{SUD}	Flip-Flop (Latch) Data Input Setup	0.4		0.4		0.5		ns
t_{HD}	Flip-Flop (Latch) Data Input Hold	0.0		0.0		0.0		ns
t_{SUENA}	Flip-Flop (Latch) Enable Setup	0.8		0.9		1.0		ns
t_{HENA}	Flip-Flop (Latch) Enable Hold	0.0		0.0		0.0		ns
t_{WCLKA}	Flip-Flop (Latch) Clock Active Pulse Width	4.5		6.0		6.5		ns
t_{WASYN}	Flip-Flop (Latch) Asynchronous Pulse Width	4.5		6.0		6.5		ns
t_A	Flip-Flop Clock Input Period	9.8		12.0		15.0		ns
t_{INH}	Input Buffer Latch Hold	0.0		0.0		0.0		ns
t_{INSU}	Input Buffer Latch Setup	0.4		0.4		0.5		ns
t_{OUTH}	Output Buffer Latch Hold	0.0		0.0		0.0		ns
t_{OUTSU}	Output Buffer Latch Setup	0.4		0.4		0.5		ns
f_{MAX}	Flip-Flop (Latch) Clock Frequency		100.0		80.0		66.0	MHz

Notes:

- For dual-module macros, use $t_{PD1} + t_{RD1} + t_{PDn}$, $t_{CO} + t_{RD1} + t_{PDn}$ or $t_{PD1} + t_{RD1} + t_{SUD}$, whichever is appropriate.
- Routing delays are for typical designs across worst-case operating conditions. These parameters should be used for estimating device performance. Post-route timing analysis or simulation is required to determine actual worst-case performance. Post-route timing is based on actual routing delay measurements performed on the device prior to shipment.
- Data applies to macros based on the S-module. Timing parameters for sequential macros constructed from C-modules can be obtained from the DirectTime Analyzer utility.
- Setup and hold timing parameters for the Input Buffer Latch are defined with respect to the PAD and the D input. External setup/hold timing parameters must account for delay from an external PAD signal to the G inputs. Delay from an external PAD signal to the G input subtracts (adds) to the internal setup (hold) time.

A1240A Timing Characteristics (continued)
(Worst-Case Commercial Conditions)

Input Module Propagation Delays			‘-2’ Speed		‘-1’ Speed		‘Std’ Speed		
Parameter	Description		Min.	Max.	Min.	Max.	Min.	Max.	Units
t _{INYH}	Pad to Y High			2.9		3.3		3.8	ns
t _{INYL}	Pad to Y Low			2.6		3.0		3.5	ns
t _{INGH}	G to Y High			5.0		5.7		6.6	ns
t _{INGL}	G to Y Low			4.7		5.4		6.3	ns
Input Module Predicted Routing Delays¹									
t _{IRD1}	FO=1 Routing Delay			4.2		4.8		5.6	ns
t _{IRD2}	FO=2 Routing Delay			4.8		5.4		6.4	ns
t _{IRD3}	FO=3 Routing Delay			5.4		6.1		7.2	ns
t _{IRD4}	FO=4 Routing Delay			5.9		6.7		7.9	ns
t _{IRD8}	FO=8 Routing Delay			7.9		8.9		10.5	ns
Global Clock Network									
t _{CKH}	Input Low to High	FO = 32		10.2		11.0		12.8	ns
		FO = 256		11.8		13.0		15.7	
t _{CKL}	Input High to Low	FO = 32		10.2		11.0		12.8	ns
		FO = 256		12.0		13.2		15.9	
t _{PWH}	Minimum Pulse Width High	FO = 32	3.8		4.5		5.5		ns
		FO = 256	4.1		5.0		5.8		
t _{PWL}	Minimum Pulse Width Low	FO = 32	3.8		4.5		5.5		ns
		FO = 256	4.1		5.0		5.8		
t _{CKSW}	Maximum Skew	FO = 32		0.5		0.5		0.5	ns
		FO = 256		2.5		2.5		2.5	
t _{SUEXT}	Input Latch External Setup	FO = 32	0.0		0.0		0.0		ns
		FO = 256	0.0		0.0		0.0		
t _{HEXT}	Input Latch External Hold	FO = 32	7.0		7.0		7.0		ns
		FO = 256	11.2		11.2		11.2		
t _P	Minimum Period	FO = 32	8.1		9.1		11.1		ns
		FO = 256	8.8		10.0		11.7		
f _{MAX}	Maximum Frequency	FO = 32		125.0		110.0		90.0	MHz
		FO = 256		115.0		100.0		85.0	

Note:

These parameters should be used for estimating device performance. Optimization techniques may further reduce delays by 0 to 4 ns. Routing delays are for typical designs across worst-case operating conditions. Post-route timing analysis or simulation is required to determine actual worst-case performance. Post-route timing is based on actual routing delay measurements performed on the device prior to shipment.

A1240A Timing Characteristics (continued)**(Worst-Case Commercial Conditions)**

Output Module Timing		‘-2’ Speed		‘-1’ Speed		‘Std’ Speed		
Parameter	Description	Min.	Max.	Min.	Max.	Min.	Max.	Units
TTL Output Module Timing¹								
t _{DLH}	Data to Pad High		8.0		9.0		10.6	ns
t _{DHL}	Data to Pad Low		10.1		11.4		13.4	ns
t _{ENZH}	Enable Pad Z to High		8.9		10.0		11.8	ns
t _{ENZL}	Enable Pad Z to Low		11.7		13.2		15.5	ns
t _{ENHZ}	Enable Pad High to Z		7.1		8.0		9.4	ns
t _{ENLZ}	Enable Pad Low to Z		8.4		9.5		11.1	ns
t _{GLH}	G to Pad High		9.0		10.2		11.9	ns
t _{GHL}	G to Pad Low		11.2		12.7		14.9	ns
d _{TLH}	Delta Low to High		0.07		0.08		0.09	ns/pF
d _{THL}	Delta High to Low		0.12		0.13		0.16	ns/pF
CMOS Output Module Timing¹								
t _{DLH}	Data to Pad High		10.2		11.5		13.5	ns
t _{DHL}	Data to Pad Low		8.4		9.6		11.2	ns
t _{ENZH}	Enable Pad Z to High		8.9		10.0		11.8	ns
t _{ENZL}	Enable Pad Z to Low		11.7		13.2		15.5	ns
t _{ENHZ}	Enable Pad High to Z		7.1		8.0		9.4	ns
t _{ENLZ}	Enable Pad Low to Z		8.4		9.5		11.1	ns
t _{GLH}	G to Pad High		9.0		10.2		11.9	ns
t _{GHL}	G to Pad Low		11.2		12.7		14.9	ns
d _{TLH}	Delta Low to High		0.12		0.13		0.16	ns/pF
d _{THL}	Delta High to Low		0.09		0.10		0.12	ns/pF

Note:

1. Delays based on 50 pF loading.
2. SSO information can be found at http://www.actel.com/support/appnotes/appnotes_design.html#board.

A1280A Timing Characteristics

(Worst-Case Commercial Conditions, $V_{CC} = 4.75\text{ V}$, $T_J = 70^\circ\text{C}$)

Logic Module Propagation Delays ¹		'-2' Speed		'-1' Speed		'Std' Speed		
Parameter	Description	Min.	Max.	Min.	Max.	Min.	Max.	Units
t_{PD1}	Single Module		3.8		4.3		5.0	ns
t_{CO}	Sequential Clk to Q		3.8		4.3		5.0	ns
t_{GO}	Latch G to Q		3.8		4.3		5.0	ns
t_{RS}	Flip-Flop (Latch) Reset to Q		3.8		4.3		5.0	ns
Predicted Routing Delays ²								
t_{RD1}	FO=1 Routing Delay		1.7		2.0		2.3	ns
t_{RD2}	FO=2 Routing Delay		2.5		2.8		3.3	ns
t_{RD3}	FO=3 Routing Delay		3.0		3.4		4.0	ns
t_{RD4}	FO=4 Routing Delay		3.7		4.2		4.9	ns
t_{RD8}	FO=8 Routing Delay		6.7		7.5		8.8	ns
Sequential Timing Characteristics ^{3,4}								
t_{SUD}	Flip-Flop (Latch) Data Input Setup	0.4		0.4		0.5		ns
t_{HD}	Flip-Flop (Latch) Data Input Hold	0.0		0.0		0.0		ns
t_{SUENA}	Flip-Flop (Latch) Enable Setup	0.8		0.9		1.0		ns
t_{HENA}	Flip-Flop (Latch) Enable Hold	0.0		0.0		0.0		ns
t_{WCLKA}	Flip-Flop (Latch) Clock Active Pulse Width	5.5		6.0		7.0		ns
t_{WASYN}	Flip-Flop (Latch) Asynchronous Pulse Width	5.5		6.0		7.0		ns
t_A	Flip-Flop Clock Input Period	11.7		13.3		18.0		ns
t_{INH}	Input Buffer Latch Hold	0.0		0.0		0.0		ns
t_{INSU}	Input Buffer Latch Setup	0.4		0.4		0.5		ns
t_{OUTH}	Output Buffer Latch Hold	0.0		0.0		0.0		ns
t_{OUTSU}	Output Buffer Latch Setup	0.4		0.4		0.5		ns
f_{MAX}	Flip-Flop (Latch) Clock Frequency		85.0		75.0		50.0	MHz

Notes:

- For dual-module macros, use $t_{PD1} + t_{RD1} + t_{PDn}$, $t_{CO} + t_{RD1} + t_{PDn}$, or $t_{PD1} + t_{RD1} + t_{SUD}$, whichever is appropriate.
- Routing delays are for typical designs across worst-case operating conditions. These parameters should be used for estimating device performance. Post-route timing analysis or simulation is required to determine actual worst-case performance. Post-route timing is based on actual routing delay measurements performed on the device prior to shipment.
- Data applies to macros based on the S-module. Timing parameters for sequential macros constructed from C-modules can be obtained from the DirectTime Analyzer utility.
- Setup and hold timing parameters for the Input Buffer Latch are defined with respect to the PAD and the D input. External setup/hold timing parameters must account for delay from an external PAD signal to the G inputs. Delay from an external PAD signal to the G input subtracts (adds) to the internal setup (hold) time.

A1280A Timing Characteristics (continued)**(Worst-Case Commercial Conditions)**

Input Module Propagation Delays			‘-2’ Speed		‘-1’ Speed		‘Std’ Speed		
Parameter	Description		Min.	Max.	Min.	Max.	Min.	Max.	Units
t _{INYH}	Pad to Y High			2.9		3.3		3.8	ns
t _{INYL}	Pad to Y Low			2.7		3.0		3.5	ns
t _{INGH}	G to Y High			5.0		5.7		6.6	ns
t _{INGL}	G to Y Low			4.8		5.4		6.3	ns
Input Module Predicted Routing Delays ¹									
t _{IRD1}	FO=1 Routing Delay			4.6		5.1		6.0	ns
t _{IRD2}	FO=2 Routing Delay			5.2		5.9		6.9	ns
t _{IRD3}	FO=3 Routing Delay			5.6		6.3		7.4	ns
t _{IRD4}	FO=4 Routing Delay			6.5		7.3		8.6	ns
t _{IRD8}	FO=8 Routing Delay			9.4		10.5		12.4	ns
Global Clock Network									
t _{CKH}	Input Low to High	FO = 32		10.2		11.0		12.8	ns
		FO = 384		13.1		14.6		17.2	
t _{CKL}	Input High to Low	FO = 32		10.2		11.0		12.8	ns
		FO = 384		13.3		14.9		17.5	
t _{PWH}	Minimum Pulse Width High	FO = 32	5.0		5.5		6.6	ns	
		FO = 384	5.8		6.4		7.6		
t _{PWL}	Minimum Pulse Width Low	FO = 32	5.0		5.5		6.6	ns	
		FO = 384	5.8		6.4		7.6		
t _{CKSW}	Maximum Skew	FO = 32		0.5		0.5		0.5	ns
		FO = 384		2.5		2.5		2.5	
t _{SUEXT}	Input Latch External Setup	FO = 32	0.0		0.0		0.0	ns	
		FO = 384	0.0		0.0		0.0		
t _{HEXT}	Input Latch External Hold	FO = 32	7.0		7.0		7.0	ns	
		FO = 384	11.2		11.2		11.2		
t _P	Minimum Period	FO = 32	9.6		11.2		13.3	ns	
		FO = 384	10.6		12.6		15.3		
f _{MAX}	Maximum Frequency	FO = 32		105.0		90.0		75.0	MHz
		FO = 384		95.0		80.0		65.0	

Note:

These parameters should be used for estimating device performance. Optimization techniques may further reduce delays by 0 to 4 ns. Routing delays are for typical designs across worst-case operating conditions. Post-route timing analysis or simulation is required to determine actual worst-case performance. Post-route timing is based on actual routing delay measurements performed on the device prior to shipment.

A1280A Timing Characteristics (continued)
(Worst-Case Commercial Conditions)

Output Module Timing		‘-2’ Speed		‘-1’ Speed		‘Std’ Speed		
Parameter	Description	Min.	Max.	Min.	Max.	Min.	Max.	Units
TTL Output Module Timing¹								
t _{DLH}	Data to Pad High		8.1		9.0		10.6	ns
t _{DHL}	Data to Pad Low		10.2		11.4		13.4	ns
t _{ENZH}	Enable Pad Z to High		9.0		10.0		11.8	ns
t _{ENZL}	Enable Pad Z to Low		11.8		13.2		15.5	ns
t _{ENHZ}	Enable Pad High to Z		7.1		8.0		9.4	ns
t _{ENLZ}	Enable Pad Low to Z		8.4		9.5		11.1	ns
t _{GLH}	G to Pad High		9.0		10.2		11.9	ns
t _{GHL}	G to Pad Low		11.3		12.7		14.9	ns
d _{TLH}	Delta Low to High		0.07		0.08		0.09	ns/pF
d _{THL}	Delta High to Low		0.12		0.13		0.16	ns/pF
CMOS Output Module Timing¹								
t _{DLH}	Data to Pad High		10.3		11.5		13.5	ns
t _{DHL}	Data to Pad Low		8.5		9.6		11.2	ns
t _{ENZH}	Enable Pad Z to High		9.0		10.0		11.8	ns
t _{ENZL}	Enable Pad Z to Low		11.8		13.2		15.5	ns
t _{ENHZ}	Enable Pad High to Z		7.1		8.0		9.4	ns
t _{ENLZ}	Enable Pad Low to Z		8.4		9.5		11.1	ns
t _{GLH}	G to Pad High		9.0		10.2		11.9	ns
t _{GHL}	G to Pad Low		11.3		12.7		14.9	ns
d _{TLH}	Delta Low to High		0.12		0.13		0.16	ns/pF
d _{THL}	Delta High to Low		0.09		0.10		0.12	ns/pF

Note:

1. Delays based on 50 pF loading.
2. SSO information can be found at http://www.actel.com/support/appnotes/appnotes_design.html#board.

Pin Description

CLKA **Clock A (Input)**

TTL Clock input for clock distribution networks. The Clock input is buffered prior to clocking the logic modules. This pin can also be used as an I/O.

CLKB **Clock B (Input)**

TTL Clock input for clock distribution networks. The Clock input is buffered prior to clocking the logic modules. This pin can also be used as an I/O.

DCLK **Diagnostic Clock (Input)**

TTL Clock input for diagnostic probe and device programming. DCLK is active when the MODE pin is HIGH. This pin functions as an I/O when the MODE pin is LOW.

GND **Ground**

LOW supply voltage.

I/O **Input/Output (Input, Output)**

The I/O pin functions as an input, output, three-state, or bidirectional buffer. Input and output levels are compatible with standard TTL and CMOS specifications. Unused I/O pins are automatically driven LOW by the ALS software.

MODE **Mode (Input)**

The MODE pin controls the use of multifunction pins (DCLK, PRA, PRB, SDI). When the MODE pin is HIGH, the special functions are active. When the MODE pin is LOW, the pins function as I/Os. To provide Actionprobe capability, the MODE pin should be terminated to GND through a 10K resistor so that the MODE pin can be pulled high when required.

NC **No Connection**

This pin is not connected to circuitry within the device.

PRA **Probe A (Output)**

The Probe A pin is used to output data from any user-defined design node within the device. This independent diagnostic pin is used in conjunction with the Probe B pin to allow real-time diagnostic output of any signal path within the device. The Probe A pin can be used as a user-defined I/O when debugging has been completed. The pin's probe capabilities can be permanently disabled to protect programmed design confidentiality. PRA is active when the MODE pin is HIGH. This pin functions as an I/O when the MODE pin is LOW.

PRB **Probe B (Output)**

The Probe B pin is used to output data from any user-defined design node within the device. This independent diagnostic pin is used in conjunction with the Probe A pin to allow real-time diagnostic output of any signal path within the device. The Probe B pin can be used as a user-defined I/O when debugging has been completed. The pin's probe capabilities can be permanently disabled to protect programmed design confidentiality. PRB is active when the MODE pin is HIGH. This pin functions as an I/O when the MODE pin is LOW.

SDI **Serial Data Input (Input)**

Serial data input for diagnostic probe and device programming. SDI is active when the MODE pin is HIGH. This pin functions as an I/O when the MODE pin is LOW.

V_{CC} **5.0V Supply Voltage**

HIGH supply voltage.

Package Pin Assignments

84-Pin PLCC

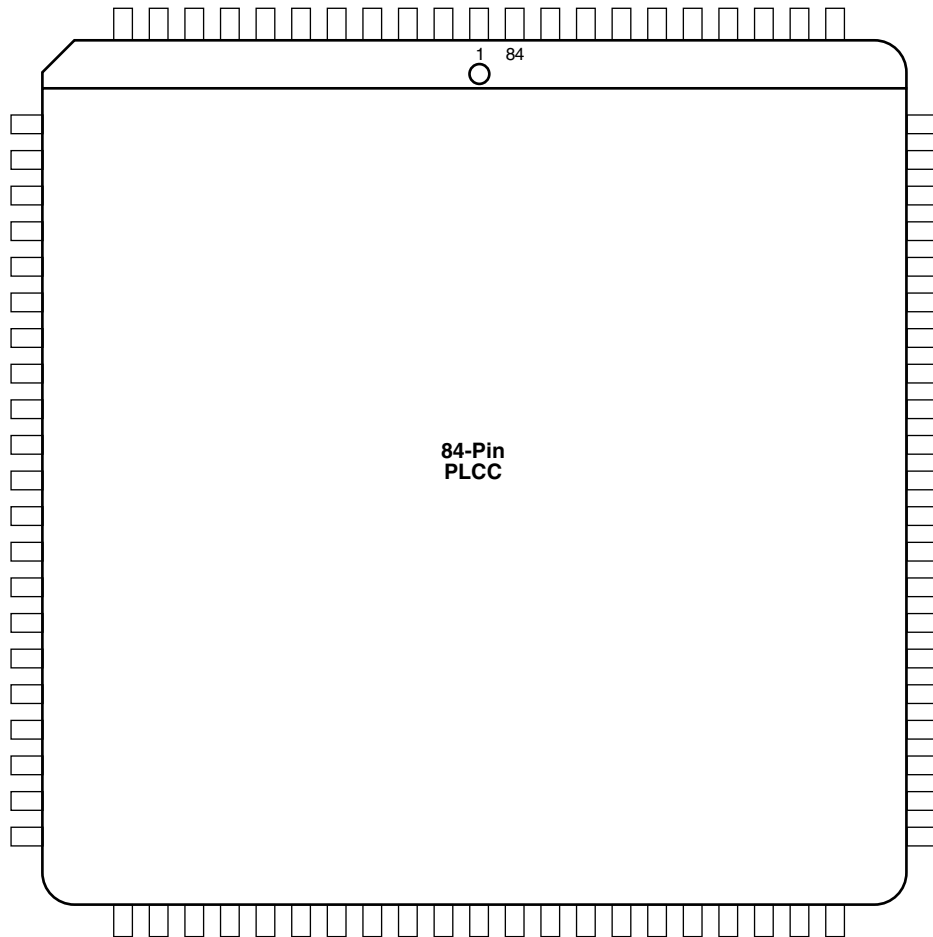

Signal	A1225A Function	A1240A Function	A1280A Function
2	CLKB, I/O	CLKB, I/O	CLKB, I/O
4	PRB, I/O	PRB, I/O	PRB, I/O
6	GND	GND	GND
10	DCLK, I/O	DCLK, I/O	DCLK, I/O
12	MODE	MODE	MODE
22	VCC	VCC	VCC
23	VCC	VCC	VCC
28	GND	GND	GND

Notes:

1. All unlisted pin numbers are user I/Os.
2. MODE pin should be terminated to GND through a 10K resistor to enable Actionprobe usage, otherwise it can be terminated directly to GND.

Package Pin Assignments

84-Pin PLCC

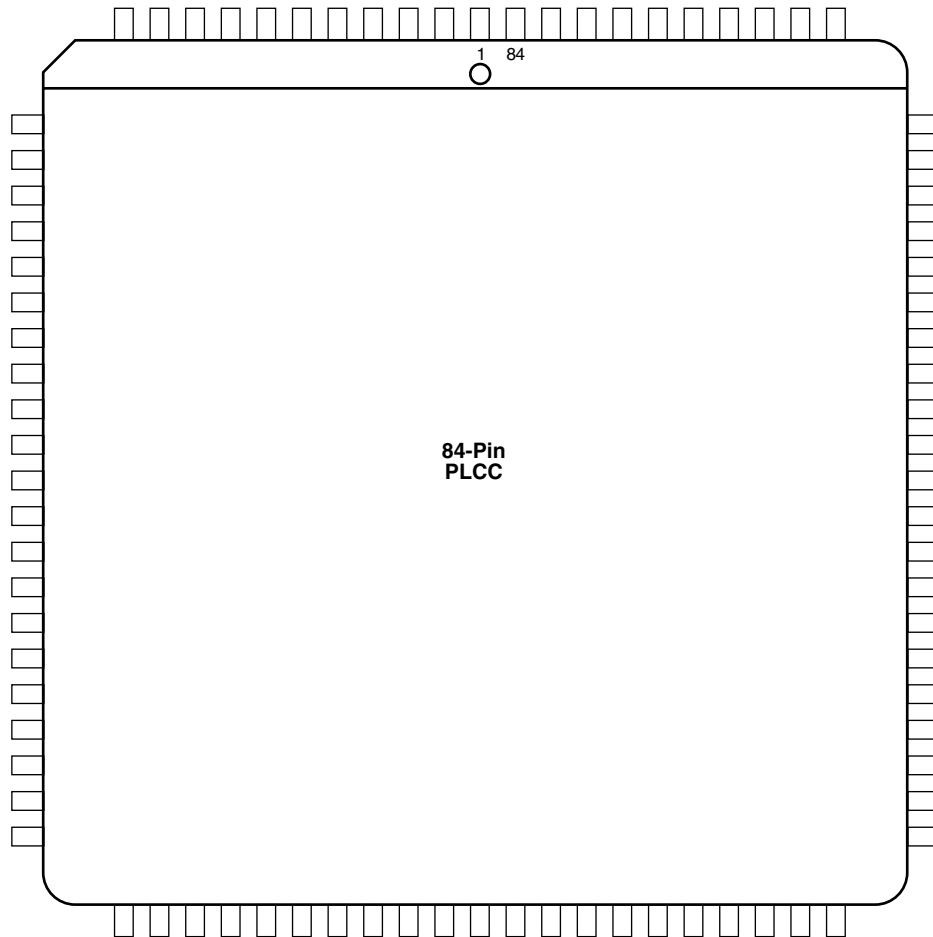

Signal	A1225A Function	A1240A Function	A1280A Function
43	VCC	VCC	VCC
49	GND	GND	GND
63	GND	GND	GND
64	VCC	VCC	VCC
65	VCC	VCC	VCC
70	GND	GND	GND
76	SDI, I/O	SDI, I/O	SDI, I/O
81	PRA, I/O	PRA, I/O	PRA, I/O
83	CLKA, I/O	CLKA, I/O	CLKA, I/O
84	VCC	VCC	VCC

Notes:

1. All unlisted pin numbers are user I/Os.
2. MODE pin should be terminated to GND through a 10K resistor to enable Actionprobe usage, otherwise it can be terminated directly to GND.

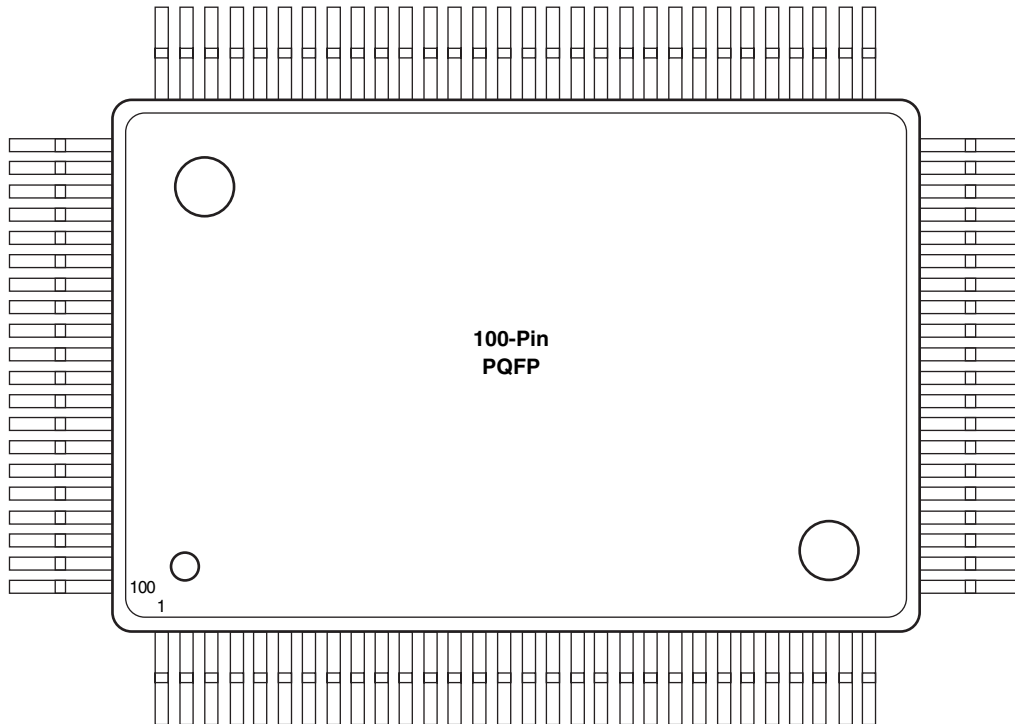
Package Pin Assignments (continued)
100-Pin PQFP

Pin Number	A1225A Function
2	DCLK, I/O
4	MODE
9	GND
16	VCC
17	VCC
22	GND
34	GND
40	VCC
46	GND
57	GND
64	GND
65	VCC

Pin Number	A1225A Function
66	VCC
67	VCC
72	GND
79	SDI, I/O
84	GND
87	PRA, I/O
89	CLKA, I/O
90	VCC
92	CLKB, I/O
94	PRB, I/O
96	GND

Notes:

1. All unlisted pin numbers are user I/Os.
2. MODE pin should be terminated to GND through a 10K resistor to enable Actionprobe usage, otherwise it can be terminated directly to GND.

Package Pin Assignments (continued)

144-Pin PQFP

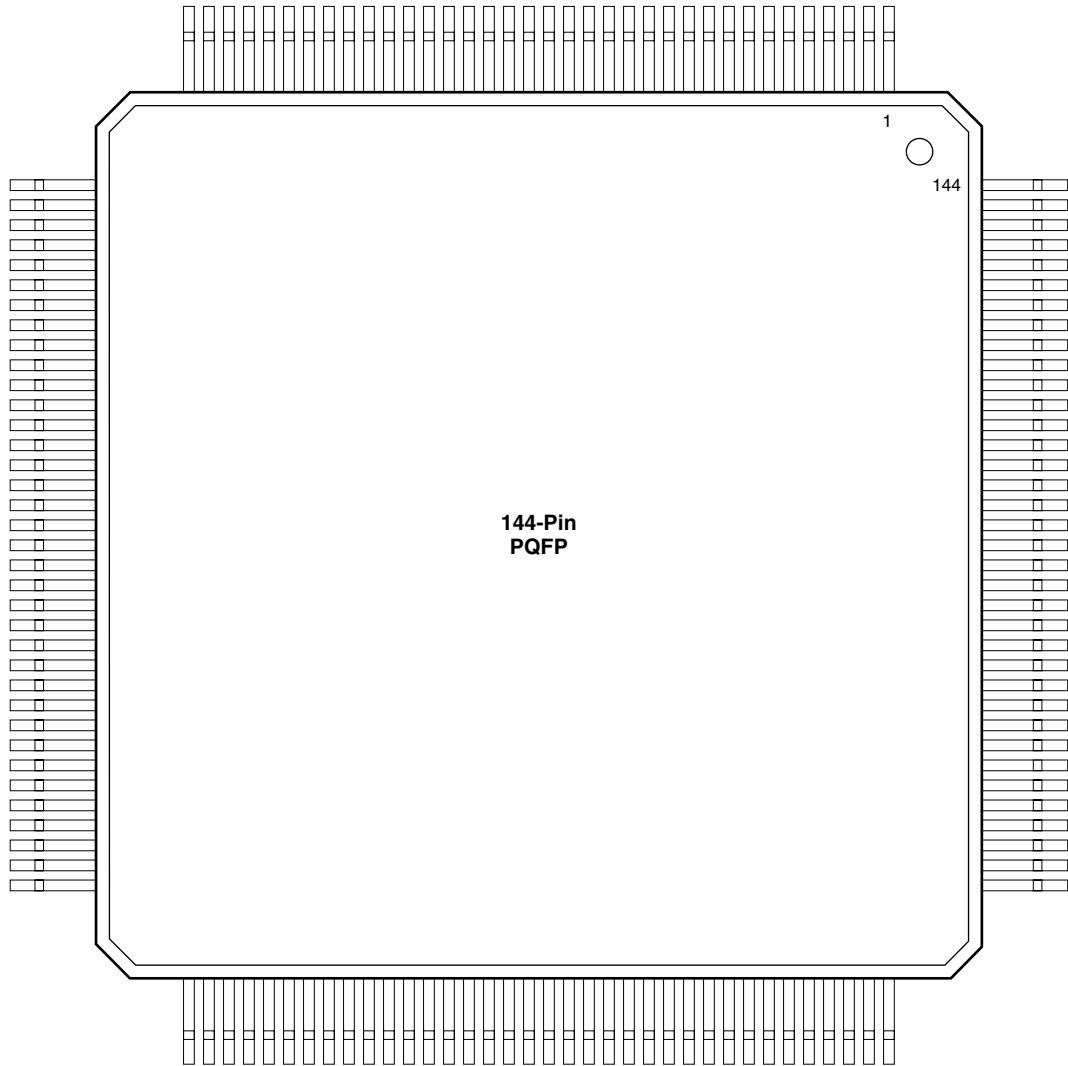

144-Pin PQFP

Pin Number	A1240A Function
2	MODE
9	GND
10	GND
11	GND
18	VCC
19	VCC
20	VCC
21	VCC
28	GND
29	GND
30	GND
44	GND
45	GND
46	GND
54	VCC
55	VCC
56	VCC
64	GND
65	GND
79	GND
80	GND
81	GND
88	GND

Pin Number	A1240A Function
89	VCC
90	VCC
91	VCC
92	VCC
93	VCC
100	GND
101	GND
102	GND
110	SDI, I/O
116	GND
117	GND
118	GND
123	PRA, I/O
125	CLKA, I/O
126	VCC
127	VCC
128	VCC
130	CLKB, I/O
132	PRB, I/O
136	GND
137	GND
138	GND
144	DCLK, I/O

Notes:

1. All unlisted pin numbers are user I/Os.
2. MODE pin should be terminated to GND through a 10K resistor to enable Actionprobe usage, otherwise it can be terminated directly to GND.

Package Pin Assignments (continued)

160-Pin PQFP

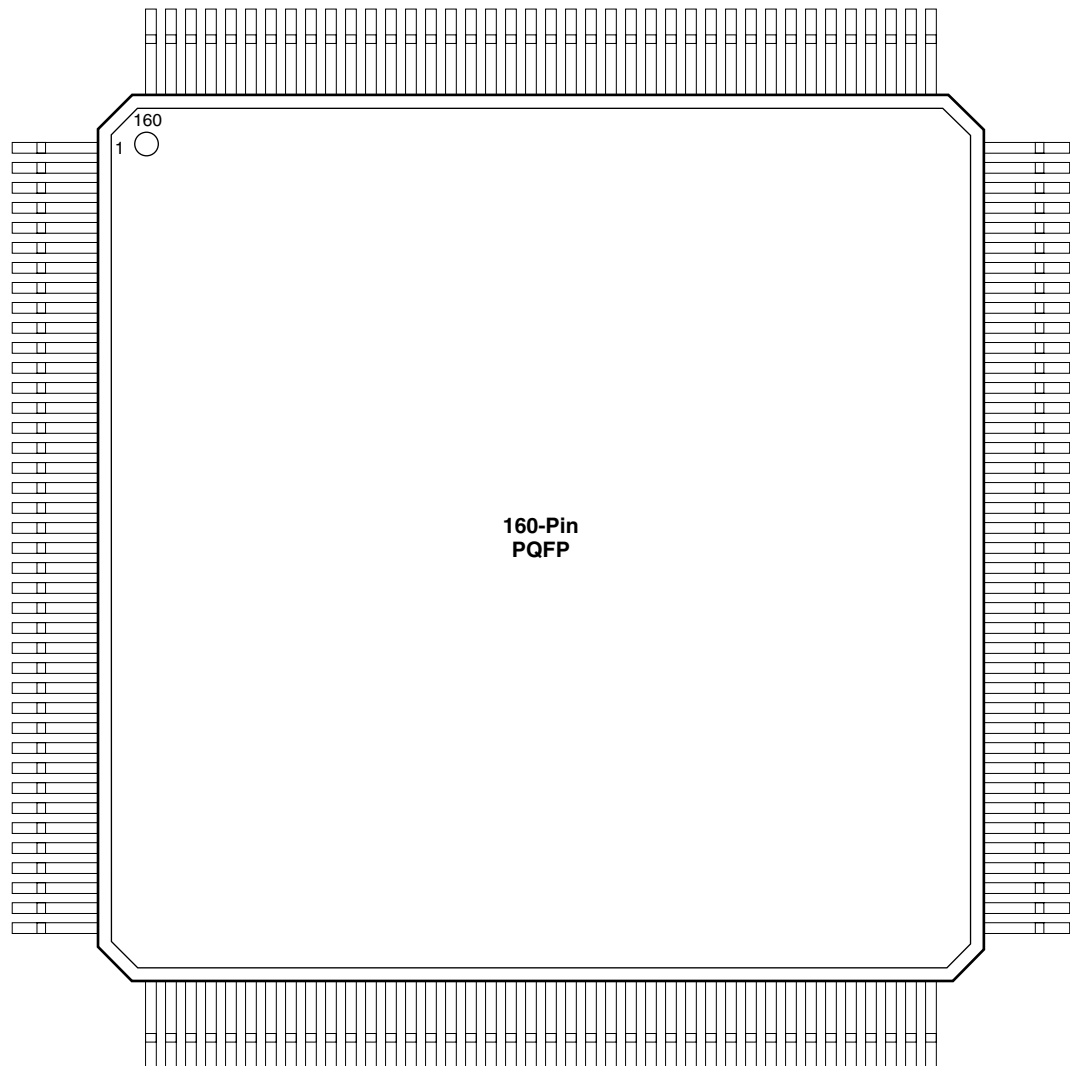

160-Pin PQFP

Pin Number	A1280A Function
2	DCLK, I/O
6	VCC
11	GND
16	PRB, I/O
18	CLKB, I/O
20	VCC
21	CLKA, I/O
23	PRA, I/O
30	GND
35	VCC
38	SDI, I/O
40	GND
44	GND
49	GND
54	VCC
57	VCC
58	VCC
59	GND
60	VCC
61	GND
64	GND

Pin Number	A1280A Function
69	GND
80	GND
86	VCC
89	GND
98	VCC
99	GND
109	GND
114	VCC
120	GND
125	GND
130	GND
135	VCC
138	VCC
139	VCC
140	GND
145	GND
150	VCC
155	GND
159	MODE
160	GND

Notes:

1. All unlisted pin numbers are user I/Os.
2. MODE pin should be terminated to GND through a 10K resistor to enable Actionprobe usage, otherwise it can be terminated directly to GND.

Package Pin Assignments (continued)

100-Pin VQFP

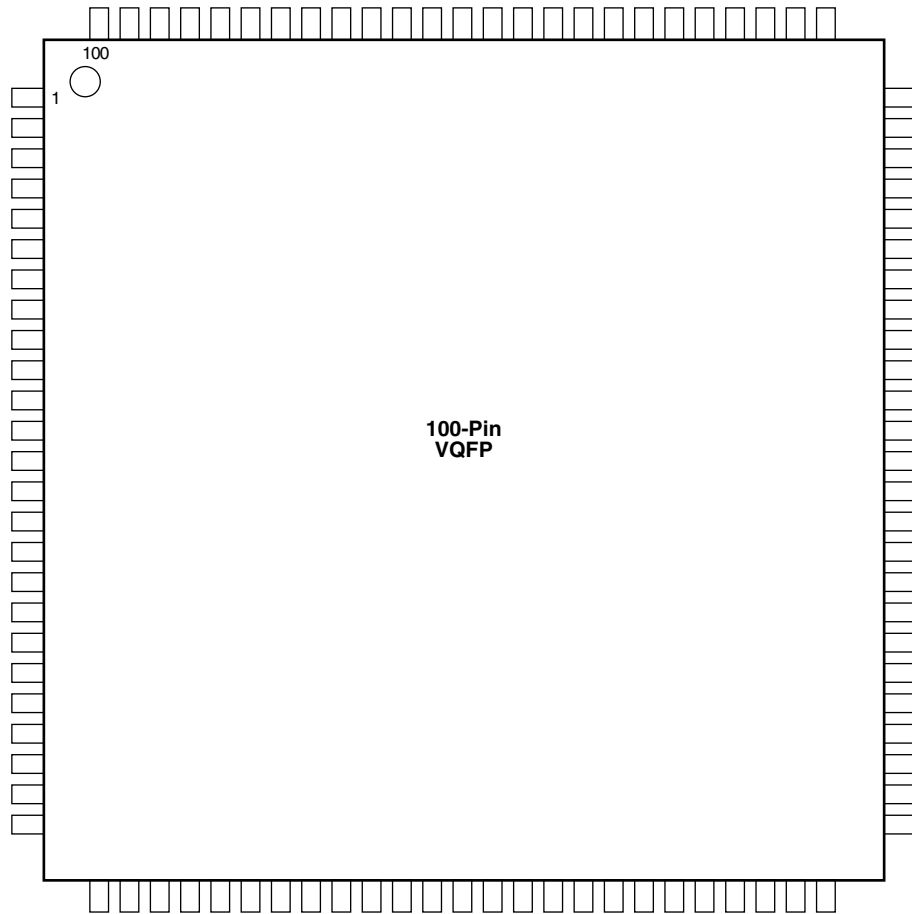

100-Pin VQFP

Pin Number	A1225A Function
2	MODE
7	GND
14	VCC
15	VCC
20	GND
32	GND
38	VCC
44	GND
55	GND
62	GND
63	VCC
64	VCC

Pin Number	A1225A Function
65	VCC
70	GND
77	SDI, I/O
82	GND
85	PRA, I/O
87	CLKA, I/O
88	VCC
90	CLKB, I/O
92	PRB, I/O
94	GND
100	DCLK, I/O

Notes:

1. All unlisted pin numbers are user I/Os.
2. MODE pin should be terminated to GND through a 10K resistor to enable Actionprobe usage, otherwise it can be terminated directly to GND.

Package Pin Assignments (continued)

176-Pin TQFP

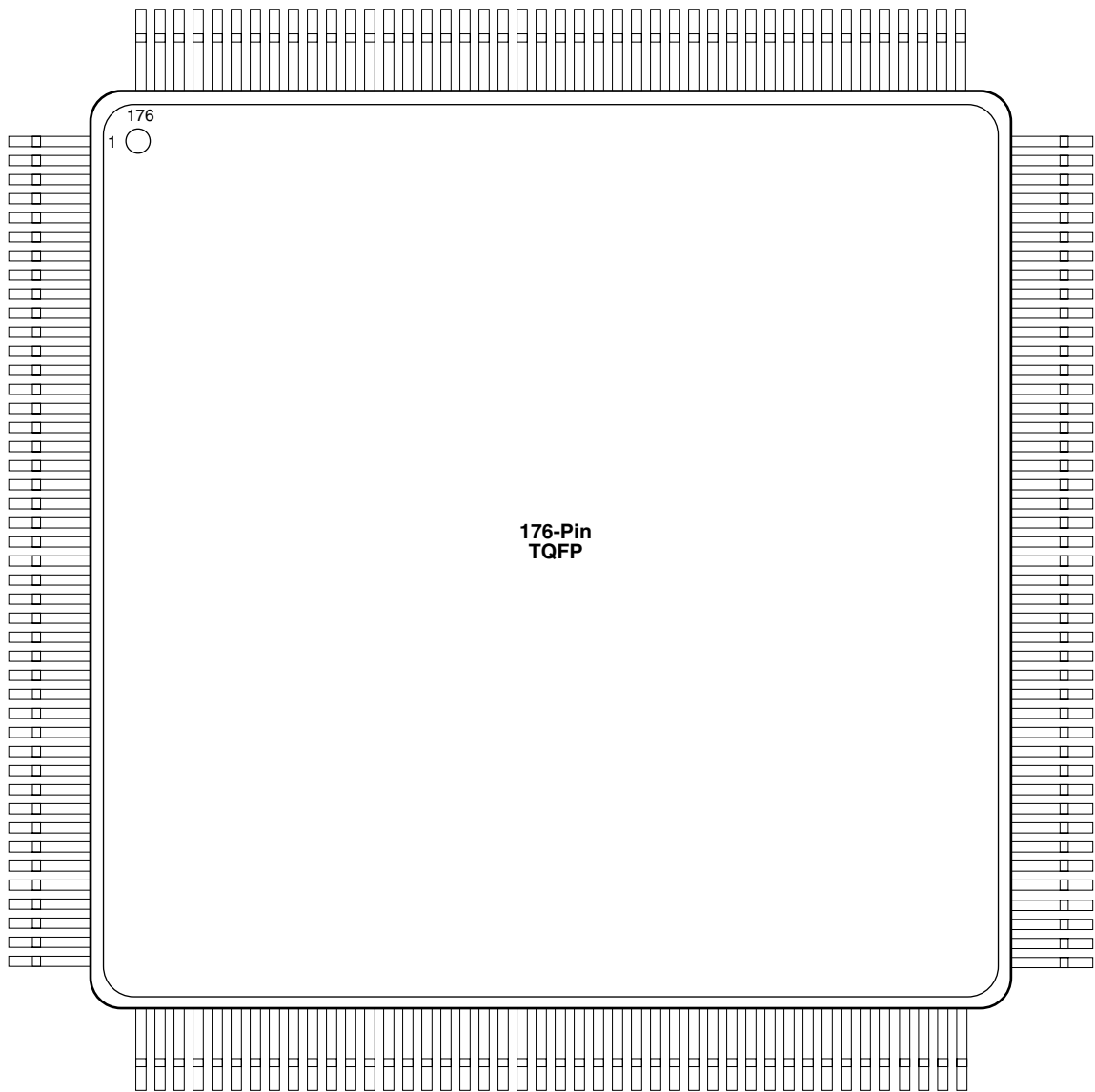

176-Pin TQFP

Pin Number	A1240A Function	A1280A Function
1	GND	GND
2	MODE	MODE
8	NC	NC
10	NC	I/O
11	NC	I/O
13	NC	VCC
18	GND	GND
19	NC	I/O
20	NC	I/O
22	NC	I/O
23	GND	GND
24	NC	VCC
25	VCC	VCC
26	NC	I/O
27	NC	I/O
28	VCC	VCC
29	NC	I/O
33	NC	NC
37	NC	I/O
38	NC	NC
45	GND	GND
52	NC	VCC
54	NC	I/O
55	NC	I/O
57	NC	NC
61	NC	I/O
64	NC	I/O
66	NC	I/O
67	GND	GND
68	VCC	VCC
74	NC	I/O
77	NC	NC
78	NC	I/O
80	NC	I/O
82	NC	VCC
86	NC	I/O
89	GND	GND
96	NC	I/O
97	NC	I/O

Pin Number	A1240A Function	A1280A Function
101	NC	NC
103	NC	I/O
106	GND	GND
107	NC	I/O
108	NC	I/O
109	GND	GND
110	VCC	VCC
111	GND	GND
112	VCC	VCC
113	VCC	VCC
114	NC	I/O
115	NC	I/O
116	NC	VCC
121	NC	NC
124	NC	I/O
125	NC	I/O
126	NC	NC
133	GND	GND
135	SDI, I/O	SDI, I/O
136	NC	I/O
140	NC	VCC
143	NC	I/O
144	NC	I/O
145	NC	NC
147	NC	I/O
151	NC	I/O
152	PRA, I/O	PRA, I/O
154	CLKA, I/O	CLKA, I/O
155	VCC	VCC
156	GND	GND
158	CLKB, I/O	CLKB, I/O
160	PRB, I/O	PRB, I/O
161	NC	I/O
165	NC	NC
166	NC	I/O
168	NC	I/O
170	NC	VCC
173	NC	I/O
175	DCLK, I/O	DCLK, I/O

Notes:

1. NC: Denotes No Connection
2. All unlisted pin numbers are user I/Os.
3. MODE pin should be terminated to GND through a 10K resistor to enable Actionprobe usage, otherwise it can be terminated directly to GND.

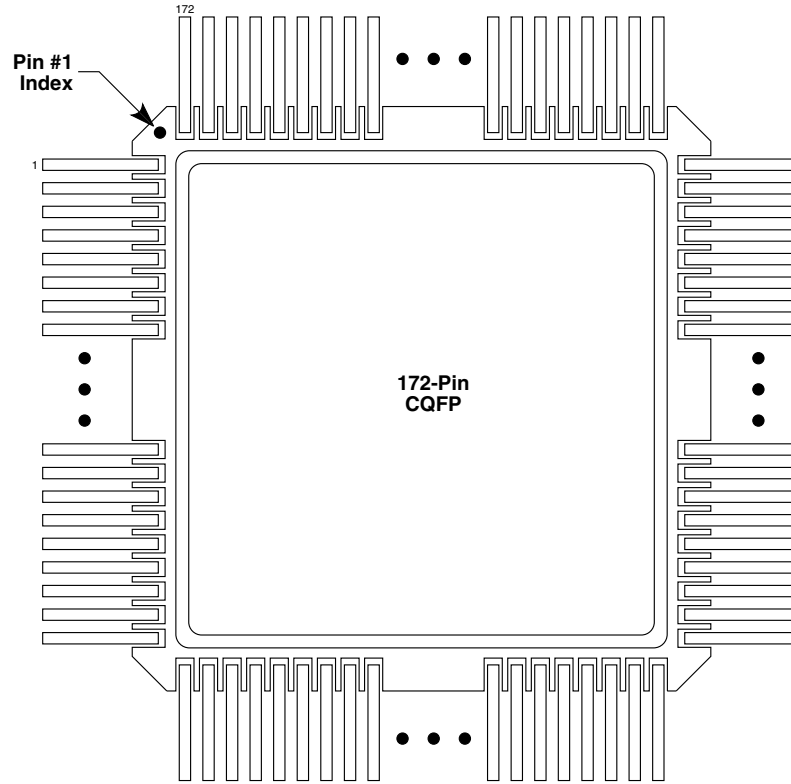
Package Pin Assignments (continued)
172-Pin CQFP

172-Pin CQFP

Pin Number	A1280A Function
1	MODE
7	GND
12	VCC
17	GND
22	GND
23	VCC
24	VCC
27	VCC
32	GND
37	GND
50	VCC
55	GND
65	GND
66	VCC
75	GND
80	VCC
98	GND
103	GND
106	GND

Pin Number	A1280A Function
107	VCC
108	GND
109	VCC
110	VCC
113	VCC
118	GND
123	GND
131	SDI, I/O
136	VCC
141	GND
148	PRA, I/O
150	CLKA, I/O
151	VCC
152	GND
154	CLKB, I/O
156	PRB, I/O
161	GND
166	VCC
171	DCLK, I/O

Notes:

1. All unlisted pin numbers are user I/Os.
2. MODE pin should be terminated to GND through a 10K resistor to enable Actionprobe usage, otherwise it can be terminated directly to GND.

Package Pin Assignments (continued)

100-Pin CPGA

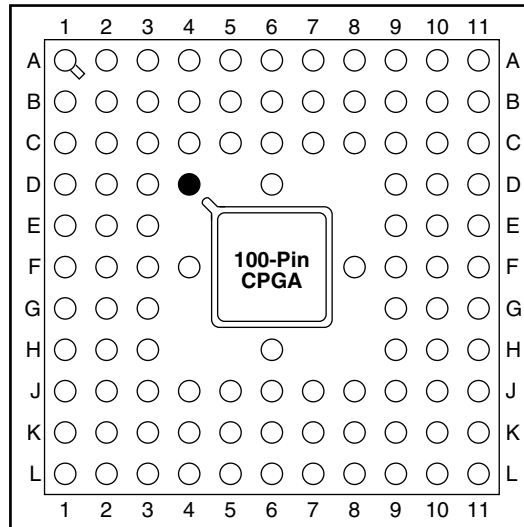

● Orientation Pin

Pin Number	A1225A Function
A4	PRB, I/O
A7	PRA, I/O
B6	VCC
C2	MODE
C3	DCLK, I/O
C5	GND
C6	CLKA, I/O
C7	GND
C8	SDI, I/O
D6	CLKB, I/O
D10	GND
E3	GND

Pin Number	A1225A Function
E11	VCC
F3	VCC
F9	VCC
F10	VCC
F11	GND
G1	VCC
G3	GND
G9	GND
J5	GND
J7	GND
K6	VCC

Note:

1. All unlisted pin numbers are user I/Os.
2. MODE pin should be terminated to GND through a 10K resistor to enable Actionprobe usage, otherwise it can be terminated directly to GND.

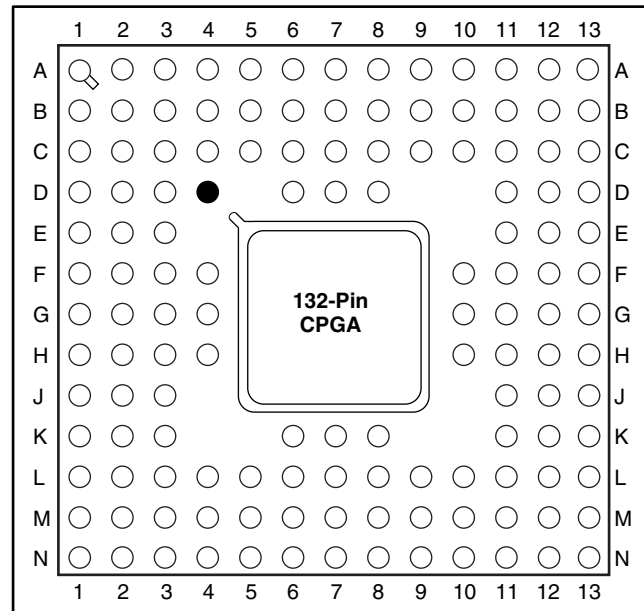
Package Pin Assignments (continued)
132-Pin CPGA

● Orientation Pin

Pin Number	A1240A Function
A1	MODE
B5	GND
B6	CLKB, I/O
B7	CLKA, I/O
B8	PRA, I/O
B9	GND
B12	SDI, I/O
C3	DCLK, I/O
C5	GND
C6	PRB, I/O
C7	VCC
C9	GND
D7	VCC
E3	GND
E11	GND
E12	GND
F4	GND

Pin Number	A1240A Function
G2	VCC
G3	VCC
G4	VCC
G10	VCC
G11	VCC
G12	VCC
G13	VCC
H13	GND
J2	GND
J3	GND
J11	GND
K7	VCC
K12	GND
L5	GND
L7	VCC
L9	GND
M9	GND

Notes:

1. All unlisted pin numbers are user I/Os.
2. MODE pin should be terminated to GND through a 10K resistor to enable Actionprobe usage, otherwise it can be terminated directly to GND.

Package Pin Assignments (continued)

176-Pin CPGA

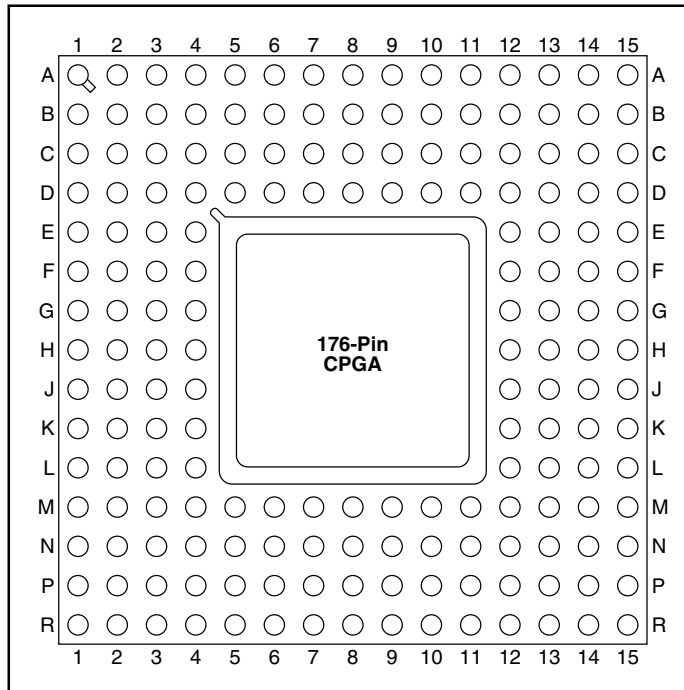

Pin Number	A1280A Function
A9	CLKA, I/O
B3	DCLK, I/O
B8	CLKB, I/O
B14	SDI, I/O
C3	MODE
C8	GND
C9	PRA, I/O
D4	GND
D5	VCC
D6	GND
D7	PRB, I/O
D8	VCC
D10	GND
D11	VCC
D12	GND
E4	GND
E12	GND
F4	VCC
F12	GND
G4	GND
G12	VCC

Pin Number	A1280A Function
H2	VCC
H3	VCC
H4	GND
H12	GND
H13	VCC
H14	VCC
J4	VCC
J12	GND
J13	GND
J14	VCC
K4	GND
K12	GND
L4	GND
M4	GND
M5	VCC
M6	GND
M8	GND
M10	GND
M11	VCC
M12	GND
N8	VCC

Notes:

1. All unlisted pin numbers are user I/Os.
2. MODE pin should be terminated to GND through a 10K resistor to enable Actionprobe usage, otherwise it can be terminated directly to GND.

List of Changes

The following table lists critical changes that were made in the current version of the document.

Previous version	Changes in current version (production (unmarked) v4.0.1–web-only)	Page
unspecified	In the 176-Pin CPGA package, pin A3 was incorrectly assigned as CLKA, I/O. A3 is a user I/O. Pin A9 is CLKA, I/O	35

Data Sheet Categories

In order to provide the latest information to designers, some data sheets are published before data has been fully characterized. These data sheets are marked as “Advanced” or Preliminary” data sheets. The definition of these categories are as follows:

Advanced

The data sheet contains initial estimated information based on simulation, other products, devices, or speed grades. This information can be used as estimates, but not for production.

Preliminary

The data sheet contains information based on simulation and/or initial characterization. The information is believed to be correct, but changes are possible.

Unmarked (production)

The data sheet contains information that is considered to be final.

Actel and the Actel logo are registered trademarks of Actel Corporation.
All other trademarks are the property of their owners.



<http://www.actel.com>

Actel Europe Ltd.

Daneshill House, Lutyens Close
Basingstoke, Hampshire RG24 8AG
United Kingdom

Tel: +44 (0)1256 305600

Fax: +44 (0)1256 355420

Actel Corporation

955 East Arques Avenue
Sunnyvale, California 94086
USA

Tel: (408) 739-1010

Fax: (408) 739-1540

Actel Asia-Pacific

EXOS Ebisu Bldg. 4F
1-24-14 Ebisu Shibuya-ku
Tokyo 150 Japan

Tel: +81 03-3445-7671

Fax: +81 03-3445-7668