



## How to Simplify the Addition of Wireless Connectivity to Your Embedded Design

Wireless connectivity continues to expand quickly across all industries as wider varieties of electronic devices and appliances add wireless controls and communications. Consumers are used to the convenience that these RF additions offer, and wireless functionality is becoming a basic requirement for most electronics products. However, implementing wireless connectivity is seldom easy. RF considerations, such as antenna design and modulation settings, can be very different from the requirements of traditional on-board controls. Additionally, regulatory standards and consumer expectations mean it is essential to achieve good wireless performance. Most inexpensive wireless solutions use very basic components that have poor performance and are difficult to implement. Solutions that are simple to implement often don't have the flexibility needed for good performance, and these seemingly simple solutions can also be costly. Fortunately, it is possible to find wireless solutions that offer high performance, ease of use and low cost, if you know what to look for.

### Regulatory Compliance

Frequency Usage: Regulatory bodies in each country or region set the most basic performance requirements for wireless systems. These agencies regulate the frequencies on which a given application may operate, the magnitude of radiated emissions and, in many cases, the timing of the transmissions. The specific standards vary widely since each region has allocated the available radio spectrum differently. In the U.S., most applications using an unlicensed band will be operating under FCC Part 15.231 (260-470 MHz), FCC Part 15.240 (433.5-434.5 MHz) or FCC Part 15.247 and 15.249 (902-928 MHz). In Europe, these applications must comply with ETSI EN 300-220 (138.2-138.45 MHz, 433.05-434.45MHz and 863-870 MHz). Elsewhere, different local standards, such as ANATEL in Brazil and ARIB in Japan, will apply.



Figure 1. Unlicensed Bands around the World

**Transmit Power Limitations:** The main requirements of these wireless system standards are radiated power versus frequency and the limitation of transmitted power of intended signals and out-of-band spurs and harmonics. The requirement for the main signal is often specified as both a maximum average power level and a maximum peak power level. For example, FCC Part 15.240 specifies a maximum average field strength of 11 mV/m at 3 m but allows up to 55 mV/m at 3 m peak field strength. This field strength permits the device to transmit at higher peak power levels if it is duty cycled. Some standards take this requirement even further and set specific guidelines for the periodicity of the transmission or for frequency hopping schemes.

**Out-of-Band Restrictions:** The out-of-band performance restrictions are much more stringent. Each standards body provides a limit for any transmitted power that goes outside of the designated band. These restrictions can vary by frequency depending on the importance of the potentially blocked application. The FCC provides a list of restricted bands and allows a maximum of 500  $\mu\text{V}/\text{m}$  field strength at 3 m (equivalent to -41 dBm EIRP) above 960 MHz and 200  $\mu\text{V}/\text{m}$  at 3 m (equivalent to -49 dBm EIRP) below 960 MHz inside these bands. All other frequencies must maintain at least 20 dBc suppression unless using Part 15.249, in which case the -41 dBm and -49 dBm limit applies to all spurs and harmonics. For any application operating in the 902-928 MHz band, this means that any near-band spurs and the third harmonic can be particular areas of concern. In all regions, out-of-band transmitter performance will be one of the major design considerations.

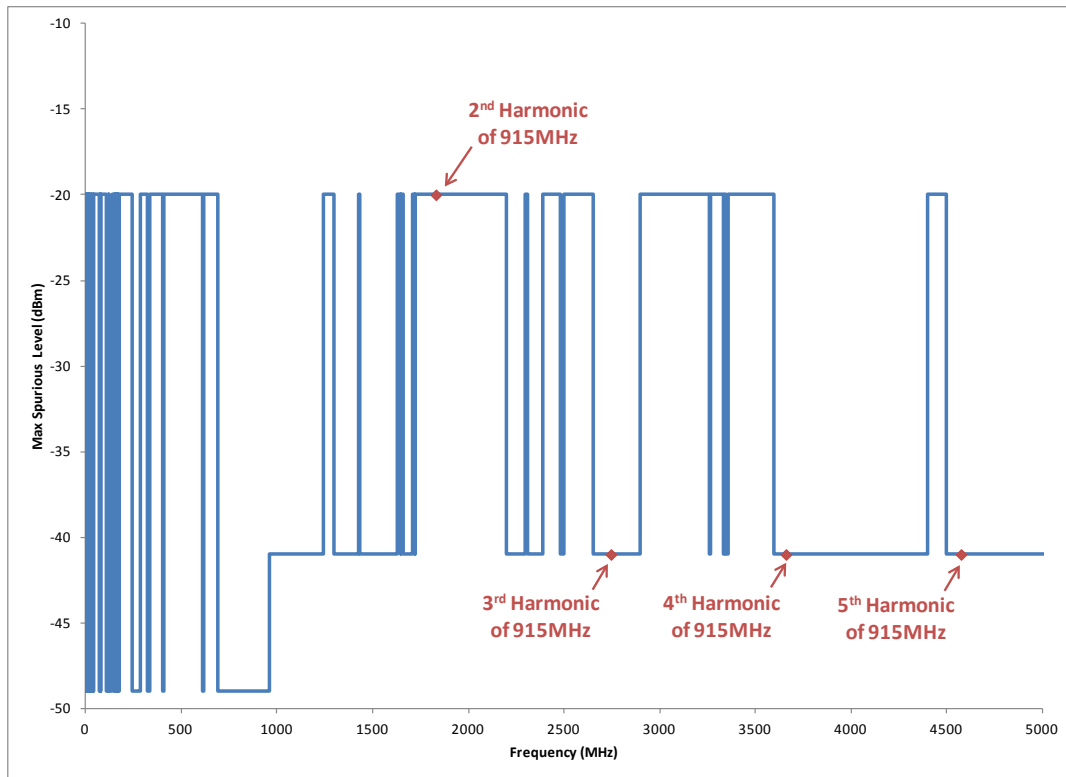

**Figure 2. FCC Spurious Level Restrictions by Frequency**

## Customer Expectations

The demands placed on wireless systems by consumers can be even more stringent than the regulatory requirements. Having portable, reliably connected wireless devices is now taken for granted, and consumers assume that any wireless product they buy will continue to operate under any environmental conditions, regardless of RF interference sources or physical barriers. They also expect that each new generation of wireless-capable products has longer range and longer battery life than previous products. The result is an increasing demand for selectivity, range and efficiency.

Receiver Selectivity: The selectivity of the receiver determines how well it can distinguish the desired transmission from other signals and noise in the area. Achieving good performance generally requires either the addition of filtering or the use of a device with high selectivity and blocking specs. Additional filtering is the least desirable of these two options since it adds both cost and loss to the system, reducing the sensitivity of the receiver.

Range: Range is another important parameter. Having sufficient range to effectively pass through walls and other barriers is usually very important, even when having a long line-of-site range is not critical. Achieving good range depends on the antenna gain, receiver sensitivity and transmitter power. The antenna gain is usually limited by cost and device form factor. Most consumer wireless applications use a PCB trace antenna for cost, but these have poor gain (often less than -20 dB) compared to other antenna options. Receiver sensitivity is another parameter affecting range and is the best variable to optimize if possible. This sets the lower limit on power that can still be received and understood; thus, finding a receiver with both good sensitivity and selectivity makes it easier to achieve the desired range requirements. This approach also provides more flexibility and design margin for the antenna design and transmitter settings. In addition, range is determined on the transmitter side by the output power level. However, there may be restrictions on how high this can be set. Increasing the transmitter power also increases the current consumption, which can have a negative effect on battery life. Additionally, regulatory standards limit the allowed output power.

Power: Finally, consumers care a great deal about battery life, so the device's power efficiency is critical. To maximize power efficiency, both active and shutdown current are important considerations since most applications employ some form of duty cycling. In applications that spend the majority of the time off, shutdown current can be even more important than active current.

## Hardware Design Considerations

How easily all of these requirements are realized in the wireless application depends somewhat on the topology of the solution. In general, for a given wireless product, the higher the integration, the easier the implementation will be. The level of integration ranges from a fully discrete solution requiring transistor biasing and matching up to a fully self-contained integrated solution. Many applications opt for a partially discrete solution, such as the system shown in Figure 3. This approach has the advantage of providing a known transmitter but still requires a number of external components for operation. A fully-integrated solution, such as that shown in Figure 4, requires almost no external components; much of the filtering and tuning work is performed internal to the part or by the inherent filtering of the antenna.

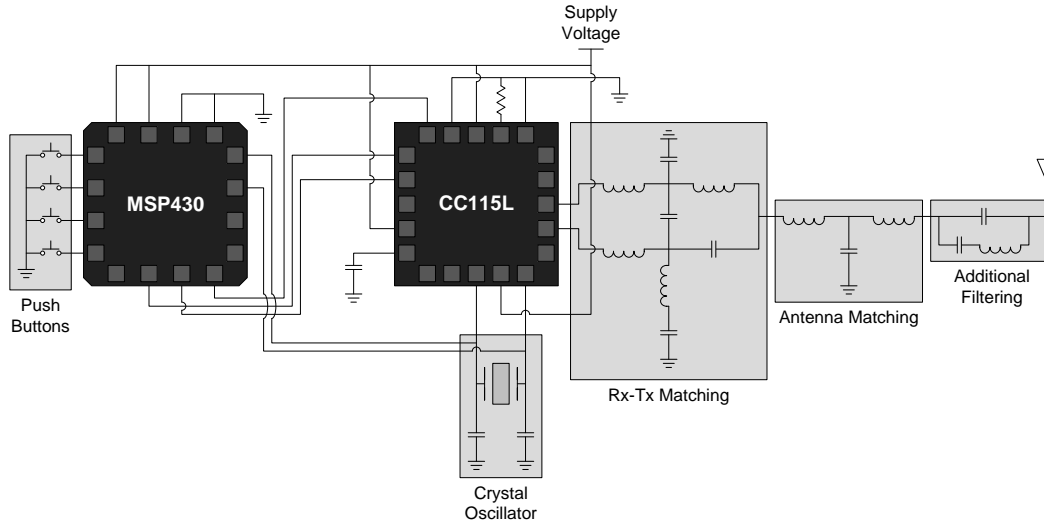

**Figure 3. Partial Discrete Transmit Solution (TI CC115L + MSP430)**

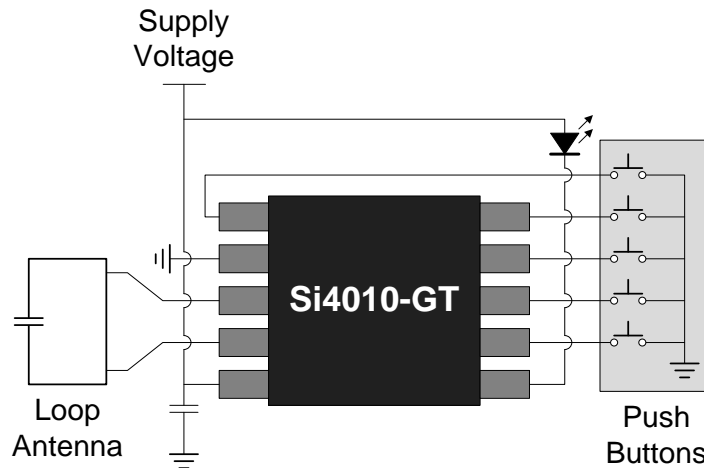

**Figure 4. Fully Integrated Transmit Solution (Silicon Labs Si4010 Transmitter)**

**Antenna Selection:** The most common antenna used in wireless systems is a small PCB trace antenna, but higher gain monopole and wire helical antennas are sometimes used in high-performance applications. The PCB antenna will ideally be one-quarter wavelength on the center frequency used, but product form factor constraints normally restrict the available size and put a greater burden on the matching elements, further reducing antenna gain.

The antenna matching and additional filtering depend on the antenna used and the performance of the wireless IC. Little additional filtering may be required if a transmitter with good harmonic performance or a receiver with good selectivity and blocking is used. However, if the wireless device has poor out-of-band performance, then special care will need to be given to filter out any offending frequencies. In addition, the quality of the match will affect the loss of the system. Selecting a receiver with good sensitivity can reduce the margin of error for the match, simplifying the design.

## Device Configuration Considerations

Wireless devices also must be configured to correctly send and receive information. Modulation type, data rate, frequency deviation and receiver bandwidth are some of the basic parameters that determine how this device configuration is achieved. The choice of data rate is generally a balance between a low data rate to optimize range or a high data rate to optimize battery life. Data rate is also affected by the amount of data, with large data applications, such as audio or video transmissions, requiring higher data rates.

The performance of the wireless IC and the accuracy of the frequency source (crystal) affect the frequency deviation and receiver bandwidth. The receiver bandwidth determines how much total noise is allowed in the system and thus has a major influence on system sensitivity and overall range. However, it must be large enough to account for the transmitter and receiver oscillator tolerance errors and for the frequency deviation distance if frequency shift keying (FSK) modulation is used. Wireless IC features, such as automatic frequency calibration, can help to keep the receiver bandwidth narrow even if a cheaper, less accurate crystal is selected. Optimizing all of these parameters is very important to ensure good performance.

For some wireless devices, the configuration is performed by setting registers within the part. However, register settings can be difficult since a single configuration parameter may affect multiple register settings. Some devices include application programming interface (API) code that translates the individual register settings into more manageable and more easily understood commands. These commands are then sent to the device through an interface (usually an SPI or I2C interface) between the wireless IC and the microcontroller (MCU).

## Wireless Solution Example

Wireless systems have many performance requirements and implementation complexities. The first design goal should be to find a solution that provides an easy and inexpensive way to balance the demands of regulatory requirements, consumer expectations and implementation concerns. The ideal wireless solution will incorporate an inexpensive, high-performance wireless device with developer-friendly application tools that allow easy implementation. For example, the Si4455 EZRadio<sup>®</sup> transceiver from Silicon Labs has high output power and surpasses most other wireless devices in important areas, such as current consumption, sensitivity, selectivity and blocking. It also includes additional features not found in many similar wireless devices, such as automatic frequency control and an internal packet handler that takes care of the communication data structure.

Additionally, Silicon Labs provides a demonstration board (see Figure 5) that can be used as an evaluation tool and as a good basis for the hardware design. The demo board is available in two sections, an RF section and an MCU section. This configuration makes it possible to test the board by itself or to remove the RF section and test in the final application. Silicon Labs also provides full schematics and layout files for download at [www.silabs.com/EZRadio](http://www.silabs.com/EZRadio) so that the board can be used as a reference design.

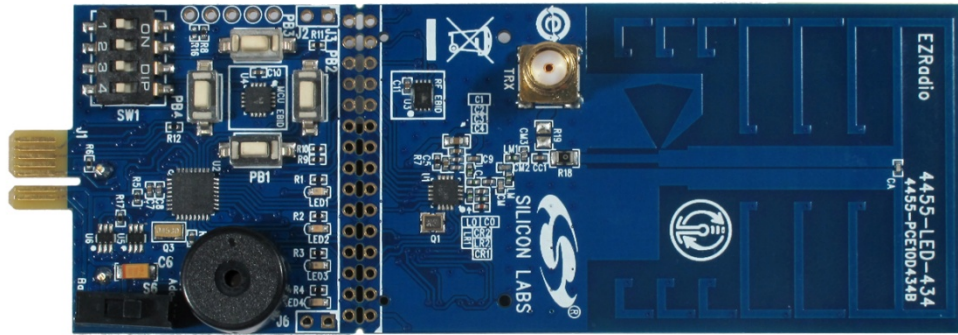

Figure 5. Si4455 EZRadio Demo Board

### Easing the Configuration Challenge

An easy-to-use configuration tool for EZRadio devices simplifies the development process (as shown in Figure 6) and helps the developer determine the optimal settings for each application. A configuration wizard (see Figure 7) helps ensure that a design stays within the regulatory standards and provides a list of possible configurations that Silicon Labs has optimized and tested. There is also the option to provide a desired frequency and oscillator tolerance, letting the software determine the receiver bandwidth that will give the best performance. Once this is done, the software provides all of the code needed to configure the device and can even provide demo code that can be used as a starting point for the application program.

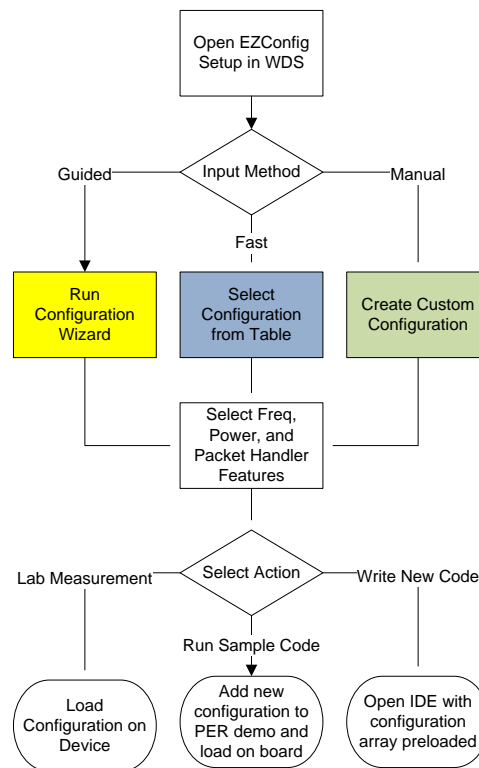
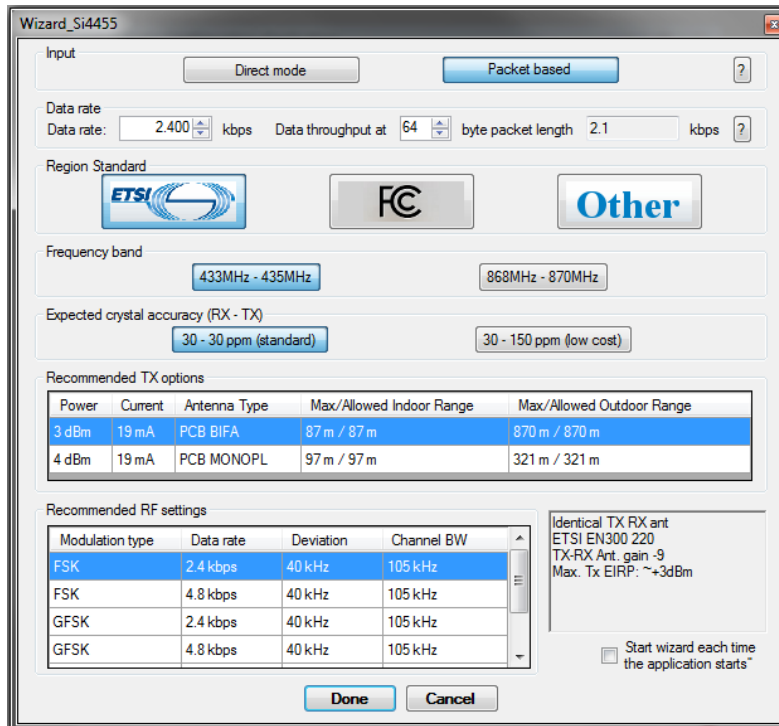

Figure 6. EZConfig Device Configuration Steps



**Figure 7. EZConfig Setup Wizard in the Wireless Development Suite Software**

Overall, this type of wireless product can provide a comprehensive solution for many design requirements and greatly simplifies the task of implementing wireless connectivity in an application. The high performance, ease-of-use and helpful support tools result in more design margin and easier implementation. In addition, the system-level cost for this kind of solution will usually be less since the wireless IC product is relatively inexpensive, and the number and cost of additional support components is minimized due to the device's high performance and integrated features.

## Conclusion

Implementing a wireless design can be challenging given the requirements of consumers and various regulatory bodies and the complex decisions that must be made regarding hardware design and system configuration. Fortunately, highly-integrated wireless IC products, such as Silicon Labs' EZRadio devices, can provide inexpensive, easy-to-implement solutions that offer the high performance needed to satisfy regulatory standards and consumer needs while providing on-chip features and development tools that make it easier to add wireless connectivity to virtually any embedded application.