



**Next Generation Peripherals
For 8-bit PIC® Microcontrollers**

Unique integrated peripherals for 8-bit PIC microcontrollers.

**8-bit MCUs with Integrated
Next Generation Peripherals**



**Configurable
Logic Cell
(CLC)**

Integrated
combinational and
sequential logic

**Complementary
Waveform
Generator (CWG)**

Flexible input source
waveform generator

**Programmable
Switch Mode
Controller (PSMC)**

Advanced PWM for power,
motor & lighting control

**Numerically
Controlled
Oscillator (NCO)**
Linear frequency control

8-bit Peripheral Highlights

Overview

Microchip is the leader in 8-bit microcontrollers by continually investing and expanding upon the PIC® microcontroller line-up. Emphasis is persistently focused on reducing costs while developing products with a strong mix of peripherals such as LCD drive, PWM, ADC, comparators, timers and communication. Beyond standard peripherals, Microchip is constantly bringing additional value to PIC microcontrollers by developing unique and exclusive peripherals. These unique peripherals allow embedded engineers to simplify their designs and create ever more creative applications and products. This innovation is demonstrated by some of the following PIC microcontroller integrated peripherals.

Configurable Logic Cell (CLC) – Easily create custom combination and sequential logic.

Key Features

- User configurable real time logic control
 - CLC configuration GUI for quick turn development
- Combinational Logic Functions
 - AND/OR/XOR/NOT/NAND/NOR/XNOR
- State Functions/Clock
 - D Flip-Flop, JK Flip-Flop D Latch, SR Latch
- Input sources
 - Pins
 - Peripherals
- Output available to:
 - External pins
 - Other peripherals
- Operation while in Sleep

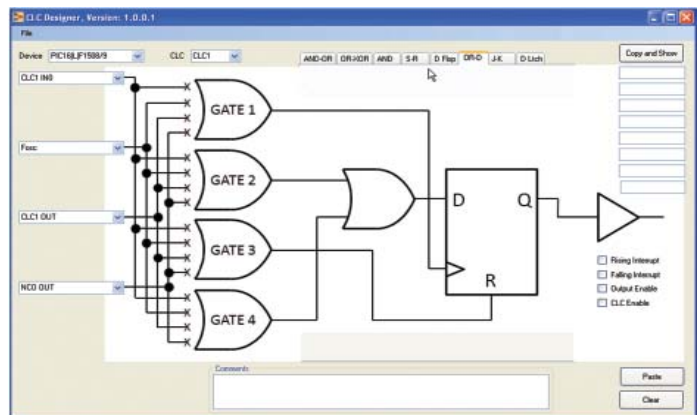

Benefits

- Increases on chip interconnection of peripherals and I/O
- Integrates hardware functions and saves board space
- Software control of Combinational/Sequential Logic
- Saves program code space and frees up CPU cycles

Example Applications

- Data Modulation
- Power Sequencing
- Manchester/IrDA Encoder
- Switch Mode Power Supply
- Event Sequencing
- Conditional Signaling
- General Purpose Logic
- Customizable Circuitry
- Smart System Control
- Boost Regulator with Feedback

Example: Phase Shifted Data Modulator

Combinational and Sequential logic can easily be designed using on-chip hardware.

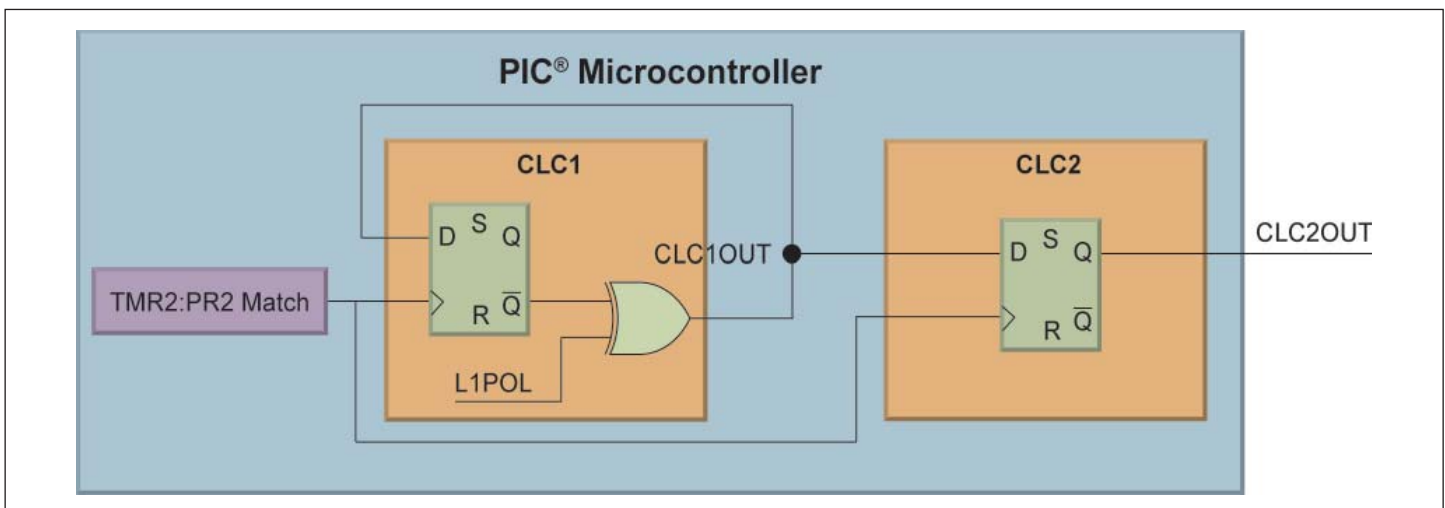

Available on the following PIC microcontrollers: PIC10F32X, PIC1XF150X.

8-bit Peripheral Highlights

Complementary Waveform Generator (CWG) Complementary Output Generator (COG)

Complementary waveforms with enhanced capabilities.

Key Features

- Provides non-overlapping complementary waveform
- Various input sources inclusive of:
 - Comparators, PWM, CLC, NCO
- Blanking control for transient filtering ¹ (available with COG only in PIC12F752)
- Phase control for output delay ² (available with COG only in PIC12F752)
- Independent rise and fall ^{3/4}
- Dead band control
- Auto shutdown/restart
- Polarity control

Benefits

- Works with multiple peripherals
- Fewer components and less space
- Lower power
- Improved switching efficiencies

Example Applications

- Switch Mode Power Supplies
- LED/Fluorescent Lighting
- Battery Charger
- Motor Drive
- Power Factor Correction
- Class D Audio Amplifiers

Example: Half Bridge Circuit Using CWG or COG

Use CWG's or COG's advanced features to provide dead-band control, auto shut down.

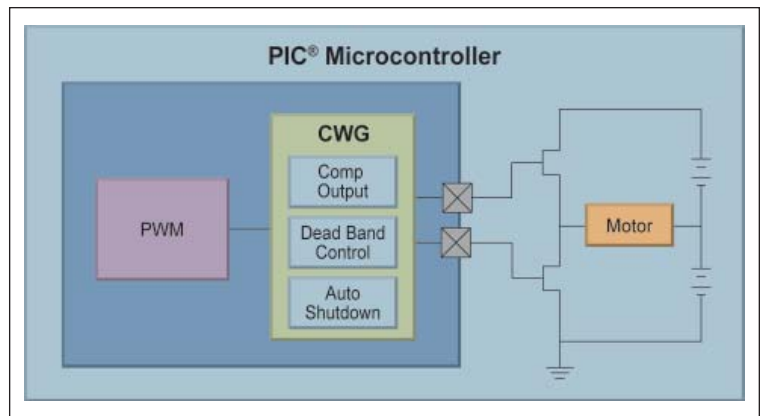

Example: LED Buck Converter

- CWG or COG frequency is determined by frequency of PWM
- CWG or COG provide dead-band control for the synchronous switches
- Use CWG's or COG's advanced features to provide auto shut down, polarity control

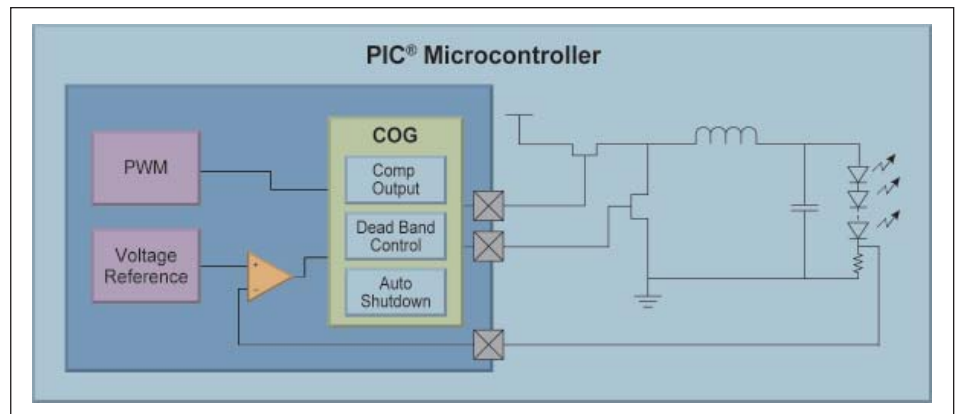

Complementary Waveform Generator (CWG)/Complementary Output Generator (COG)

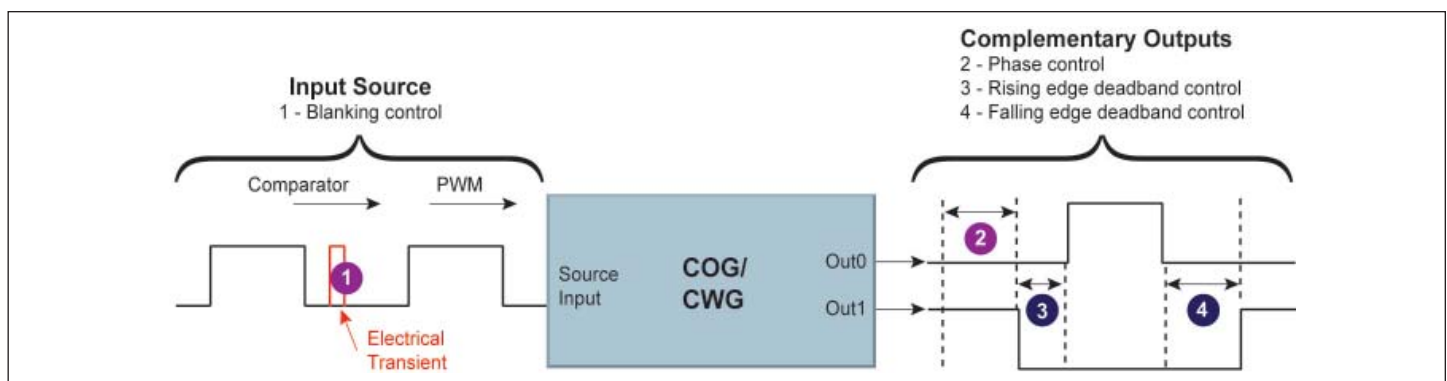

Available on the following PIC microcontrollers: PIC10F32X, PIC12F752, PIC1XF150X.

8-bit Peripheral Highlights

Numerically Controlled Oscillator (NCO) – Oscillator capabilities with true linear frequency control.

Key Features

- Up to 20-bit frequency resolution
- Independent 16 MHz clock input
- 16b numeric frequency control
 - 500 kHz max output
 - 15 Hz per step
- 2 output modes
 - Fixed 50% Duty Cycle (FDC) ¹
 - Pulse Frequency Modulation (PFM) ²

Benefits

- True linear frequency control
- Increased frequency resolution

Example Applications

- Fluorescent and LED Lighting Control
- Neon Lighting Control
- Lighting Ballast
- Power Supplies
- Motor Drivers
- Modems
- Class D Audio Amplifiers
- Ultrasonic Ranging

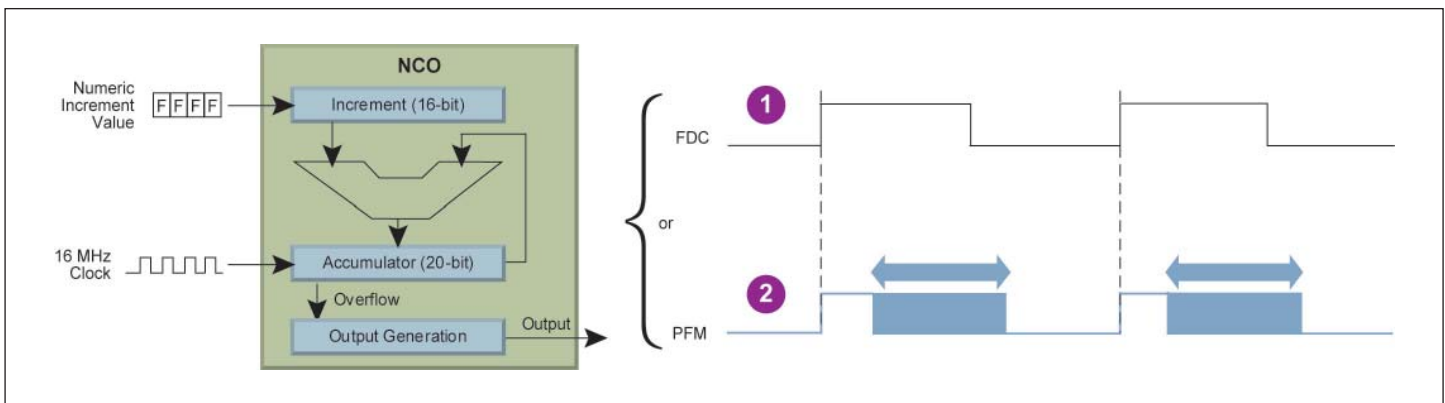

Example: Fluorescent Lighting Control

- Use the NCO to create linear frequencies for start-up and dimming control
- Lower power and extend life of fluorescent bulb

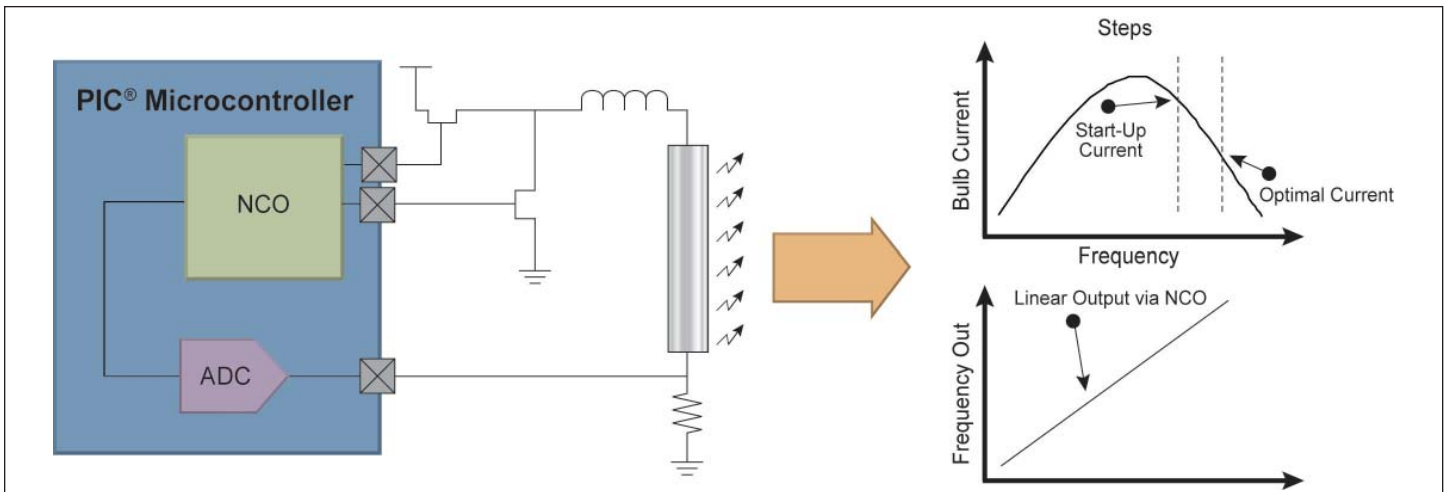

Available on the following PIC microcontrollers: PIC10F32X, PIC1XF150X.

8-bit Peripheral Highlights

Programmable Switch Mode Controller (PSMC) – Advanced PWM capabilities for power supplies, motor and lighting control.

Key Features

- Various clock sources: external, system clock, independent 64 MHz
- Various input sources: comparators, external pins
- Blanking control for transient filtering **1**
- Single 16-bit PWM
 - with up to 6 steerable outputs
- Complementary 16-bit PWM
 - with up to 3 steerable output pairs
- Independent rising/falling edge control **2**
- Dead band with independent rise and fall control **3/4**
- Polarity control/auto shutdown and restart
- Flexible PWM output modes:
 - Push/pull, pulse skipping, 3-phase, fixed duty cycle, brushed DC with forward/reverse
- Output gating – externally controlled activate/deactivate

Benefits

- Customizable high speed PWM with increased resolution and control
- Simplifies the implementation of applications such as: motor control, lighting and power supplies

Example Applications

- Power Supplies
- DC/DC Converters (Power Bricks)
- Power Factor Correction
- LCD Backlighting
- LED Lighting
- Automotive Head and Tail Lamps
- High Intensity Discharge (HID) Lighting
- Lamp Ballasts
- Signal Conditioning
- Motor Control
 - 3-phase Motors, BLDC, AC Induction
- Sensors – Medical, Temperature, Pressure
- Battery Monitoring,
- Advanced Battery Charging
- General Purpose Applications Requiring High Resolution PWM

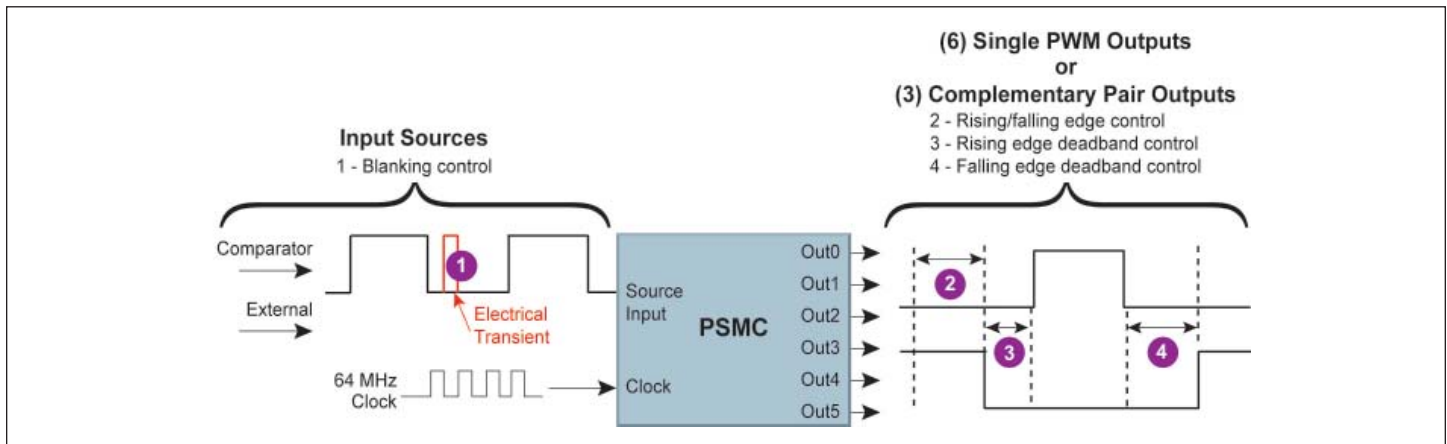

Example: LED Buck Converter

- Increased frequency control with dead-band control for the synchronous switches
- Provides auto shut down, polarity control and increased duty cycle performance

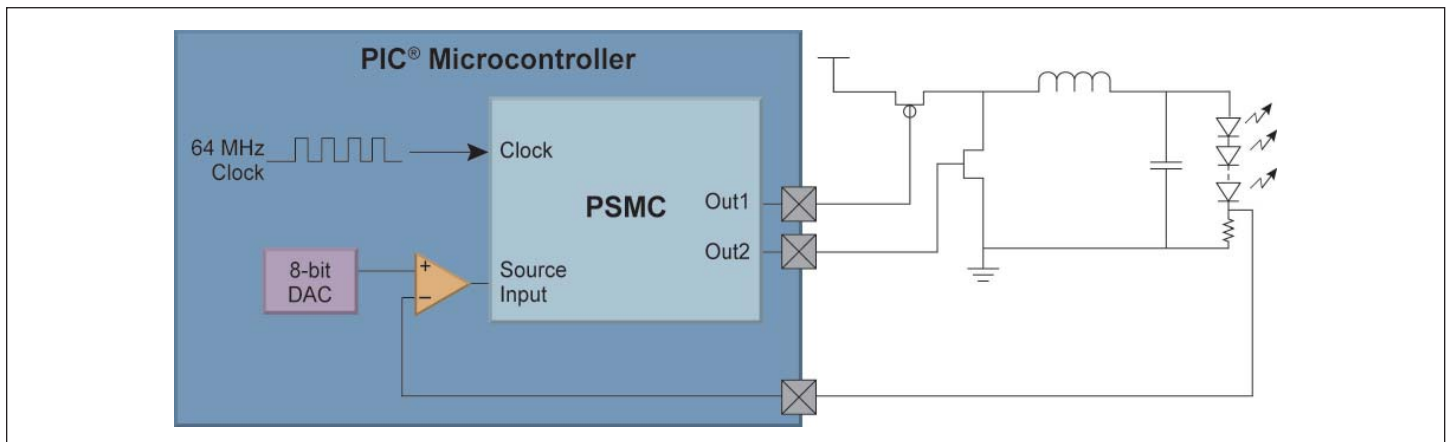

Available on the following PIC microcontrollers: PIC16F178X.

8-bit Peripheral Highlights

Temperature Indicator – Integrated temperature measurements for any application.

Key Features

- Measures between -40°C and 85°C
- Internally connected to ADC
 - ADC result changes with temperature
- Reference Application Note: AN1333

Benefits

- Low cost temp measurements for any application
- No external hardware required
- Improve RTC accuracy over temp
 - Allows the use of lower cost crystals
- Improved voltage reference over temp

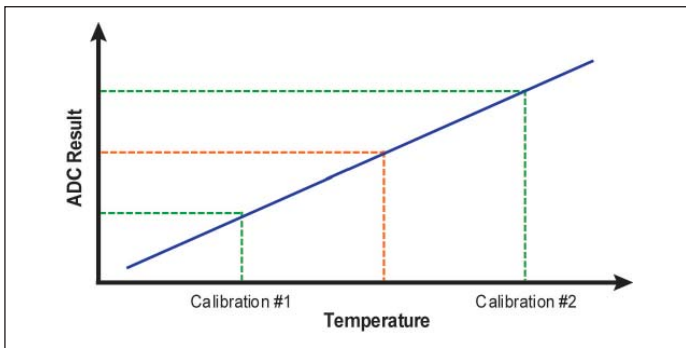

Available on the following PIC microcontrollers: PIC10F32X, PIC16F72X, PIC1XF15XX, PIC16(L)F19XX, PIC16F182X, PIC16F178X, PIC18FXK22.

Example Applications

- Mobile Phones
- Power Tools
- Home Appliances
- Any application requiring environmental temperature measurements
- Auto-shutdown to prevent system overheat
- Any application requiring oscillator accuracy over temp

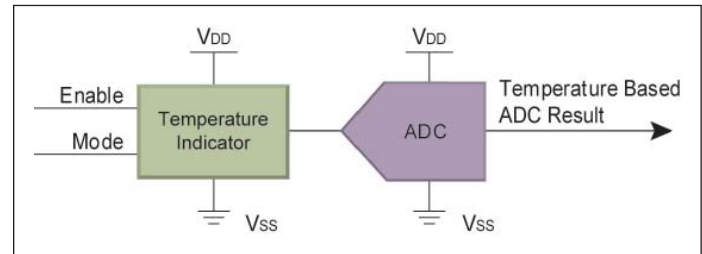

Example: Crystal Oscillator with Temperature Compensation

Enable the use of less expensive crystals while maintaining accuracy over temp.

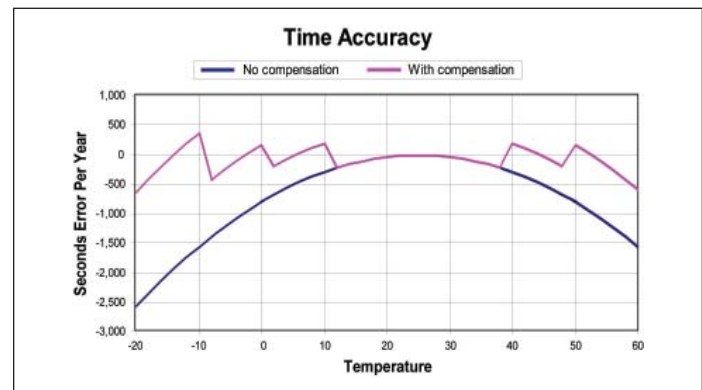

Data Signal Modulator (DSM) – Easily create custom communication protocols.

Key Features

- Modulate any input signal over a carrier frequency
- Create custom digital bit patterns
- Sources can be modulated using:
 - An external pin
 - Clock reference
 - PWM
 - UART/SPI/I²C™
 - A register bit
 - Internal comparators

Benefits

- Easily create IrDA streams or ASK, FSK or PSK transmissions

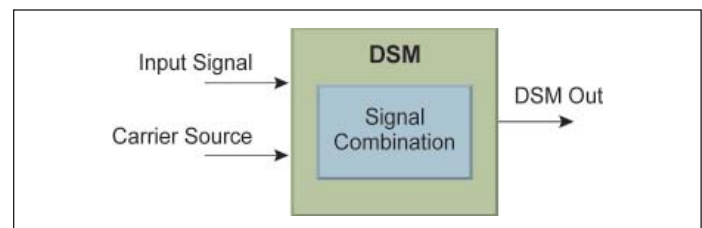

Example Applications

- Amplitude Shift Keying (ASK)
- Frequency Shift Keying (FSK)
- Phase Shift Keying (PSK)
- Modems
- IrDA stream
- Custom Communication Interface

Available on the following PIC microcontrollers: PIC16F182X/184X.

8-bit Peripheral Highlights

Timer 1 Gate (T1G) – Measures the duration of any input signal.

Key Features

- Start/stop clock input based on control signal of 16 bit Timer 1 (TMR1)
- Gating sources:
 - Comparator outputs
 - Timer 0 (TMRO)
 - External input (T1G pin)
- Clocking sources
 - Internal oscillator
 - Internal oscillator divide by 4
 - Timer 1 clock
- Pulse acquisition modes with acquisition complete interrupt flag
 - Rising to rising edge ①
 - Falling to falling edge ②
 - Falling to rising edge ③
 - Rising to falling edge ④
 - Interrupt on completion

Benefits

- Measure pulse width of any internal or external signal
- Requires no external components

Available on the following PIC microcontrollers: PIC12F15XX, PIC16F61X Family, PIC16F690 Family, PIC16F72X, PIC16F18XX, PIC16F88X, PIC16F19XX, PIC18FXK22.

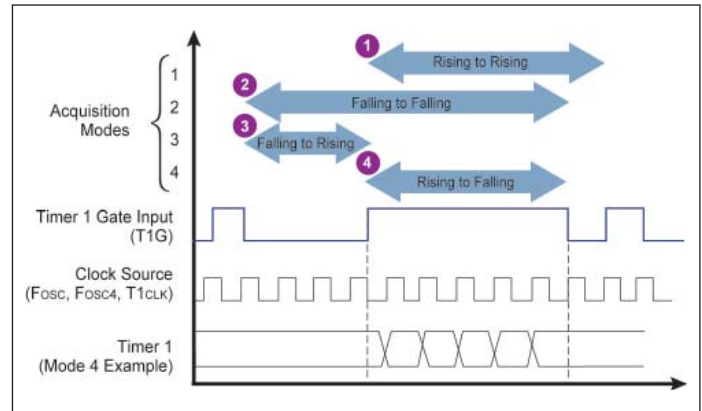

Example Applications

- Delta Sigma ADC
- PWM Decode
- SMPS Current Sharing
- Pulse Frequency Measurements
- Time Frequency Measurements

Set Reset Latch (SR Latch) – Does anything a 555 timer can do and more.

Key Features

- Internally tied to comparator
- Multiple set/reset input options
 - Comparator output
 - Software control
 - External pin
 - Programmable clock
- Latching output internal or external

Benefits

- Do anything you can do with a 555 timer
- Implement low cost wave forms and oscillators
- Few external components

Note: SR Latch capability is integrated into CLC Module

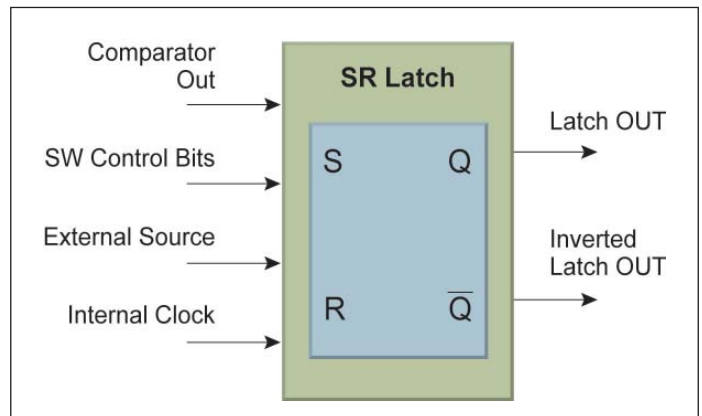

Example Applications

- Amplitude Shift Keying (ASK)
- Waveform/Pulse Generators
- Switching Power Supplies Controller
- Digital Controlled Voltage Controlled Oscillators
- Oscillators
- AC Lamp Dimmer
- PWM Motor Control
- Tone Generators
- Phase Comparators

Available on the following PIC microcontrollers: PIC16F61X, PIC16F690 Family, PIC16F18XX, PIC16F88X, PIC16F19XX, PIC18FXK22, PIC18F1XK50.

Support

Microchip is committed to supporting its customers in developing products faster and more efficiently. We maintain a worldwide network of field applications engineers and technical support ready to provide product and system assistance. In addition, the following service areas are available at www.microchip.com:

- **Support** link provides a way to get questions answered fast: <http://support.microchip.com>
- **Sample** link offers evaluation samples of any Microchip device: <http://sample.microchip.com>
- **Forum** link provides access to knowledge base and peer help: <http://forum.microchip.com>
- **Buy** link provides locations of Microchip Sales Channel Partners: www.microchip.com/sales

Sales Office Listing

AMERICAS

Atlanta

Tel: 678-957-9614

Boston

Tel: 774-760-0087

Chicago

Tel: 630-285-0071

Cleveland

Tel: 216-447-0464

Dallas

Tel: 972-818-7423

Detroit

Tel: 248-538-2250

Indianapolis

Tel: 317-773-8323

Los Angeles

Tel: 949-462-9523

Santa Clara

Tel: 408-961-6444

Toronto

Mississauga, Ontario

Tel: 905-673-0699

EUROPE

Austria - Wels

Tel: 43-7242-2244-39

Denmark - Copenhagen

Tel: 45-4450-2828

France - Paris

Tel: 33-1-69-53-63-20

Germany - Munich

Tel: 49-89-627-144-0

Italy - Milan

Tel: 39-0331-742611

Netherlands - Druen

Tel: 31-416-690399

Spain - Madrid

Tel: 34-91-708-08-90

UK - Wokingham

Tel: 44-118-921-5869

Training

If additional training interests you, then Microchip can help. We continue to expand our technical training options, offering a growing list of courses and in-depth curriculum locally, as well as significant online resources – whenever you want to use them.

- Technical Training Centers: www.microchip.com/training
- MASTERS Conferences: www.microchip.com/masters
- Worldwide Seminars: www.microchip.com/seminars
- eLearning: www.microchip.com/webseminars
- Resources from our Distribution and Third Party Partners www.microchip.com/training

ASIA/PACIFIC

Australia - Sydney

Tel: 61-2-9868-6733

China - Beijing

Tel: 86-10-8569-7000

China - Chengdu

Tel: 86-28-8665-5511

China - Chongqing

Tel: 86-23-8980-9588

China - Hangzhou

Tel: 86-571-2819-3187

China - Hong Kong SAR

Tel: 852-2401-1200

China - Nanjing

Tel: 86-25-8473-2460

China - Qingdao

Tel: 86-532-8502-7355

China - Shanghai

Tel: 86-21-5407-5533

China - Shenyang

Tel: 86-24-2334-2829

China - Shenzhen

Tel: 86-755-8203-2660

China - Wuhan

Tel: 86-27-5980-5300

China - Xiamen

Tel: 86-592-2388138

China - Xian

Tel: 86-29-8833-7252

China - Zhuhai

Tel: 86-756-3210040

ASIA/PACIFIC

India - Bangalore

Tel: 91-80-3090-4444

India - New Delhi

Tel: 91-11-4160-8631

India - Pune

Tel: 91-20-2566-1512

Japan - Yokohama

Tel: 81-45-471- 6166

Korea - Daegu

Tel: 82-53-744-4301

Korea - Seoul

Tel: 82-2-554-7200

Malaysia - Kuala Lumpur

Tel: 60-3-6201-9857

Malaysia - Penang

Tel: 60-4-227-8870

Philippines - Manila

Tel: 63-2-634-9065

Singapore

Tel: 65-6334-8870

Taiwan - Hsin Chu

Tel: 886-3-5778-366

Taiwan - Kaohsiung

Tel: 886-7-536-4818

Taiwan - Taipei

Tel: 886-2-2500-6610

Thailand - Bangkok

Tel: 66-2-694-1351

8/2/11

Microcontrollers • Digital Signal Controllers • Analog • Serial EEPROMs

The Microchip name and logo, the Microchip logo, MPLAB and PIC are registered trademarks and PICDEM, PICkit and PICtail are trademarks of Microchip Technology Incorporated in the U.S.A. and other countries. All other trademarks mentioned herein are property of their respective companies. © 2011, Microchip Technology Incorporated, All Rights Reserved. Printed in the U.S.A. 9/11 DS41565C



MICROCHIP
www.microchip.com

Microchip Technology Inc.
2355 W. Chandler Blvd.
Chandler, AZ 85224-6199