

10 MHz TO 1.4 GHz I²C PROGRAMMABLE XO/VCXO

Features

- Any programmable output frequencies from 10 to 945 MHz and select frequencies to 1.4 GHz
- I²C serial interface
- 3rd generation DSPLL[®] with superior jitter performance
- 3x better frequency stability than SAW-based oscillators
- Internal fixed crystal frequency ensures high reliability and low aging
- Available LVPECL, CMOS, LVDS, and CML outputs
- Industry-standard 5x7 mm package
- Pb-free/RoHS-compliant
- 1.8, 2.5, or 3.3 V supply

Applications

- SONET/SDH
- xDSL
- 10 GbE LAN/WAN
- Low-jitter clock generation
- Optical modules
- Clock and data recovery

Description

The Si570 XO/Si571 VCXO utilizes Silicon Laboratories' advanced DSPLL[®] circuitry to provide a low-jitter clock at any frequency. The Si570/Si571 are user-programmable to any output frequency from 10 to 945 MHz and select frequencies to 1400 MHz with <1 ppb resolution. The device is programmed via an I²C serial interface. Unlike traditional XO/VCXOs where a different crystal is required for each output frequency, the Si57x uses one fixed-frequency crystal and a DSPLL clock synthesis IC to provide any-frequency operation. This IC-based approach allows the crystal resonator to provide exceptional frequency stability and reliability. In addition, DSPLL clock synthesis provides superior supply noise rejection, simplifying the task of generating low-jitter clocks in noisy environments typically found in communication systems.

Functional Block Diagram

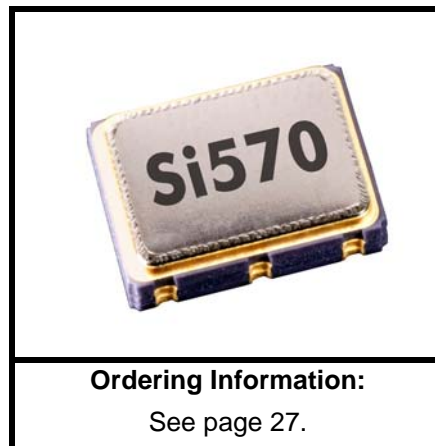
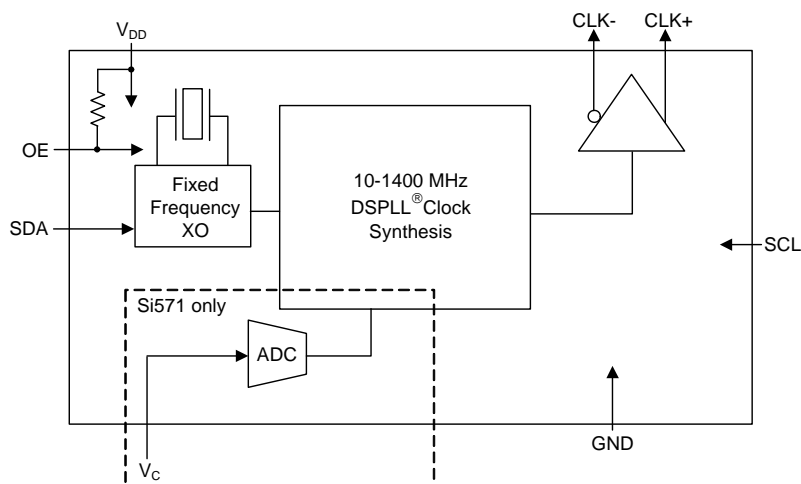

Ordering Information:

See page 27.

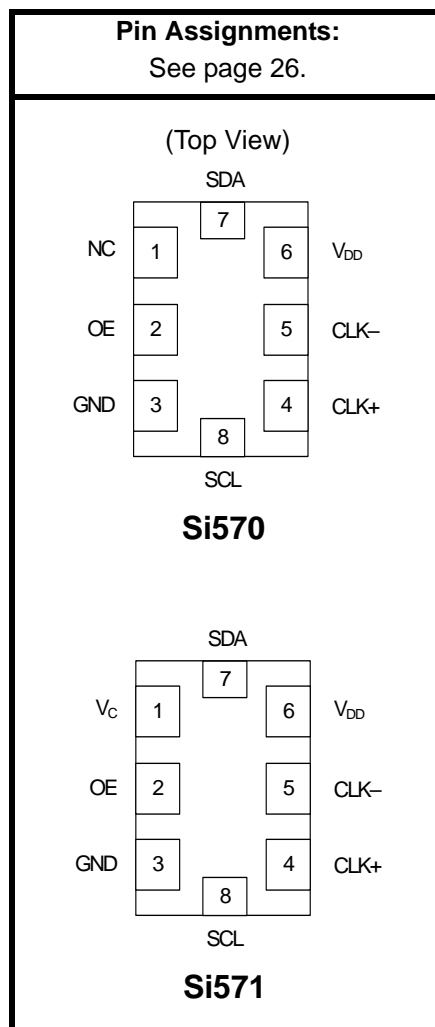

TABLE OF CONTENTS

<u>Section</u>	<u>Page</u>
1. Detailed Block Diagrams	4
2. Electrical Specifications	5
3. Functional Description	14
3.1. Programming a New Output Frequency	14
3.2. I ² C Interface	17
4. Serial Port Registers	18
5. Si570 (XO) Pin Descriptions	25
6. Si571 (VCXO) Pin Descriptions	26
7. Ordering Information	27
8. Si57x Mark Specification	28
9. Outline Diagram and Suggested Pad Layout	29
10. 8-Pin PCB Land Pattern	30
Document Change List	31
Contact Information	32

Si570/Si571

1. Detailed Block Diagrams

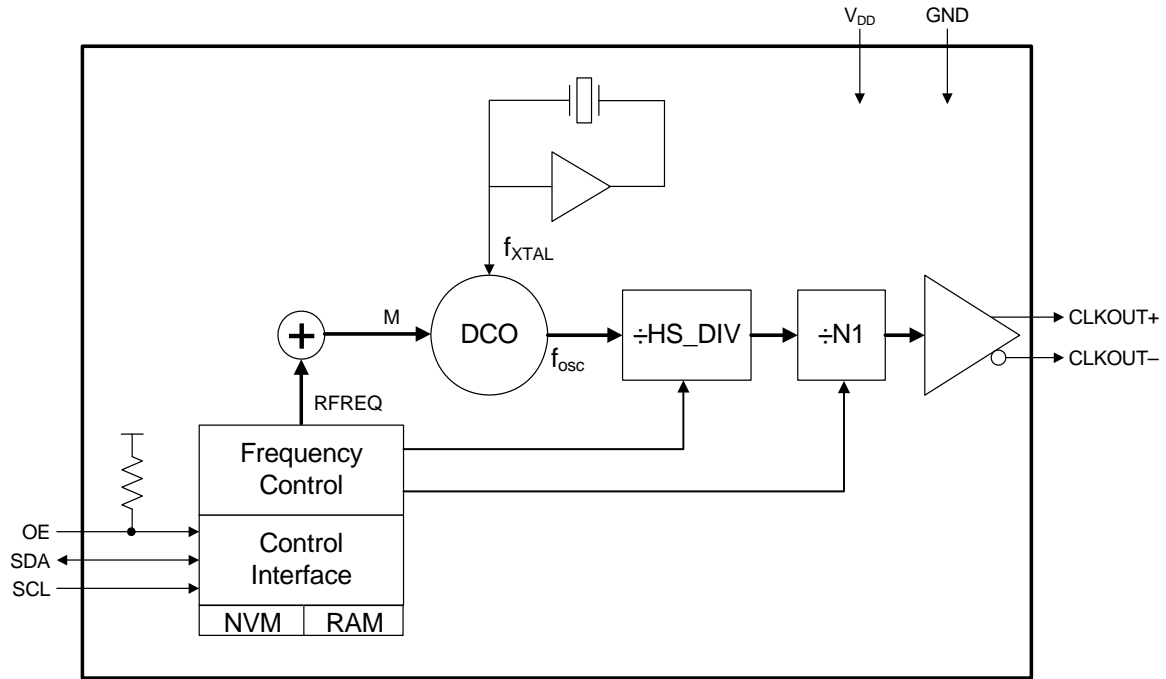

Figure 1. Si570 Detailed Block Diagram

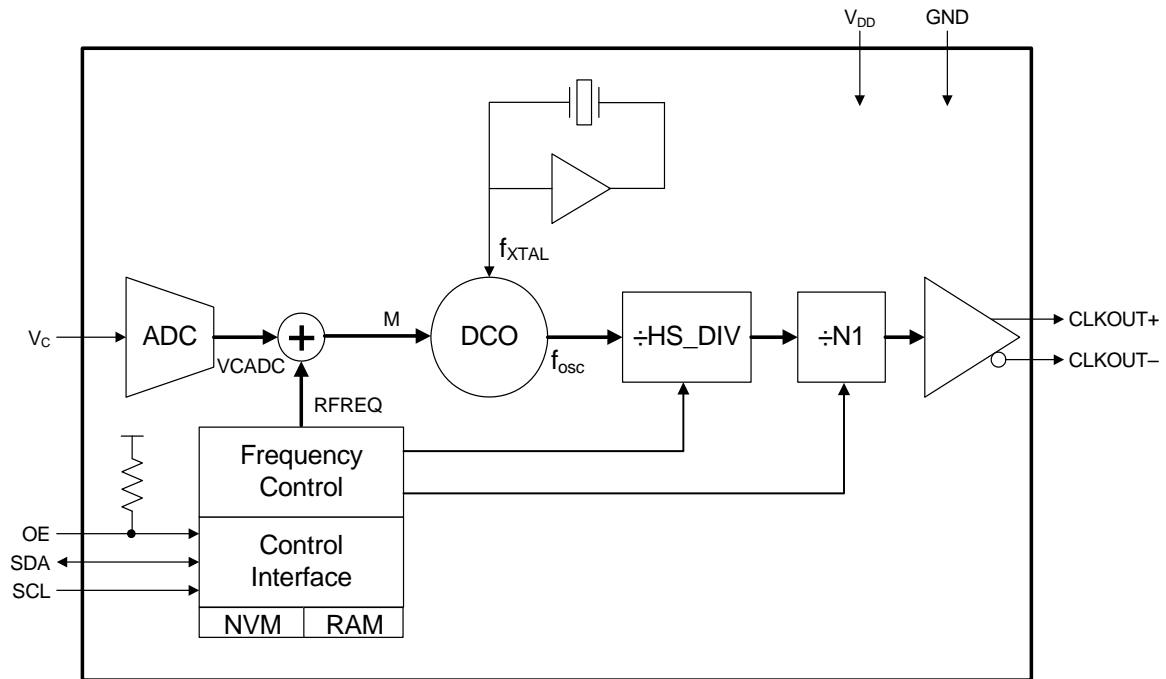

Figure 2. Si571 Detailed Block Diagram

2. Electrical Specifications

Table 1. Recommended Operating Conditions

Parameter	Symbol	Test Condition	Min	Typ	Max	Units
Supply Voltage ¹	V_{DD}	3.3 V option	2.97	3.3	3.63	V
		2.5 V option	2.25	2.5	2.75	
		1.8 V option	1.71	1.8	1.89	
Supply Current	I_{DD}	Output enabled				mA
		LVPECL	—	120	130	
		CML	—	108	117	
		LVDS	—	99	108	
		CMOS	—	90	98	
TriState mode	—	60	75			
Output Enable (OE) ² , Serial Data (SDA), Serial Clock (SCL)		V_{IH}	$0.75 \times V_{DD}$	—	—	V
		V_{IL}	—	—	0.5	
Operating Temperature Range	T_A		−40	—	85	°C

Notes:

- Selectable parameter specified by part number. See Section "7. Ordering Information" on page 27 for further details.
- OE pin includes a 17 k Ω pullup resistor to V_{DD} . See "7. Ordering Information".

Table 2. V_C Control Voltage Input

Parameter	Symbol	Test Condition	Min	Typ	Max	Units
Control Voltage Tuning Slope ^{1,2,3}	K_V	V_C 10 to 90% of V_{DD}	—	33	—	ppm/V
				45		
				90		
				135		
				180		
356						
Control Voltage Linearity ⁴	L_{VC}	BSL	−5	± 1	+5	%
		Incremental	−10	± 5	+10	
Modulation Bandwidth	BW		9.3	10.0	10.7	kHz
V_C Input Impedance	Z_{VC}		500	—	—	k Ω
Nominal Control Voltage	V_{CNOM}	@ f_O	—	$V_{DD}/2$	—	V
Control Voltage Tuning Range	V_C		0		V_{DD}	V

Notes:

- Positive slope; selectable option by part number. See "7. Ordering Information" on page 27.
- For best jitter and phase noise performance, always choose the smallest K_V that meets the application's minimum APR requirements. See "AN266: VCXO Tuning Slope (K_V), Stability, and Absolute Pull Range (APR)" for more information.
- K_V variation is $\pm 10\%$ of typical values.
- BSL determined from deviation from best straight line fit with V_C ranging from 10 to 90% of V_{DD} . Incremental slope is determined with V_C ranging from 10 to 90% of V_{DD} .

Si570/Si571

Table 3. CLK± Output Frequency Characteristics

Parameter	Symbol	Test Condition	Min	Typ	Max	Units
Programmable Frequency Range ^{1,2,3}	f _O	LVPECL/LVDS/CML	10	—	1417.5	MHz
		CMOS	10	—	160	
Temperature Stability ^{1,4}		T _A = -40 to +85 °C	-7 -20 -50 -100	— — — —	7 +20 +50 +100	ppm
Initial Accuracy			—	1.5	—	ppm
Aging	f _a	Frequency drift over first year	—	—	±3	ppm
		Frequency drift over 20-year life	—	—	±10	ppm
Total Stability		Temp stability = ±7 ppm	—	—	±20	ppm
		Temp stability = ±20 ppm	—	—	±31.5	ppm
		Temp stability = ±50 ppm	—	—	±61.5	ppm
Absolute Pull Range ^{1,4}	APR		±12	—	±375	ppm
Power up Time ⁵	t _{OSC}		—	—	10	ms
Notes: <ol style="list-style-type: none"> See Section "7. Ordering Information" on page 27 for further details. Specified at time of order by part number. Three speed grades available: Grade A covers 10 to 945 MHz, 970 to 1134 MHz, and 1213 to 1417.5 MHz. Grade B covers 10 to 810 MHz. Grade C covers 10 to 280 MHz. Nominal output frequency set by V_{CNOM} = 1/2 x V_{DD}. Selectable parameter specified by part number. Time from power up or tristate mode to f_O. 						

Table 4. CLK± Output Levels and Symmetry

Parameter	Symbol	Test Condition	Min	Typ	Max	Units
LVPECL Output Option ¹	V_O	mid-level	$V_{DD} - 1.42$	—	$V_{DD} - 1.25$	V
	V_{OD}	swing (diff)	1.1	—	1.9	V_{PP}
	V_{SE}	swing (single-ended)	0.55	—	0.95	V_{PP}
LVDS Output Option ²	V_O	mid-level	1.125	1.20	1.275	V
	V_{OD}	swing (diff)	0.5	0.7	0.9	V_{PP}
CML Output Option ²	V_O	2.5/3.3 V option mid-level	—	$V_{DD} - 1.30$	—	V
		1.8 V option mid-level	—	$V_{DD} - 0.36$	—	V
	V_{OD}	2.5/3.3 V option swing (diff)	1.10	1.50	1.90	V_{PP}
		1.8 V option swing (diff)	0.35	0.425	0.50	V_{PP}
CMOS Output Option ³	V_{OH}	$I_{OH} = 32$ mA	$0.8 \times V_{DD}$	—	V_{DD}	V
	V_{OL}	$I_{OL} = 32$ mA	—	—	0.4	V
Rise/Fall time (20/80%)	t_R, t_F	LVPECL/LVDS/CML	—	—	350	ps
		CMOS with $C_L = 15$ pF	—	1	—	ns
Symmetry (duty cycle)	SYM	LVPECL: $V_{DD} - 1.3$ V (diff) LVDS: 1.25 V (diff) CMOS: $V_{DD}/2$	45	—	55	%
Notes:						
1. 50Ω to $V_{DD} - 2.0$ V.						
2. $R_{term} = 100 \Omega$ (differential).						
3. $C_L = 15$ pF						

Table 5. CLK± Output Phase Jitter

Parameter	Symbol	Test Condition	Min	Typ	Max	Units
Phase Jitter (RMS) ¹ for F _{OUT} ≥ 500 MHz	ϕ _J	12 kHz to 20 MHz (OC-48)	—	0.25	0.40	ps
		50 kHz to 80 MHz (OC-192)	—	0.26	0.37	
Phase Jitter (RMS) ¹ for F _{OUT} of 125 to 500 MHz	ϕ _J	12 kHz to 20 MHz (OC-48)	—	0.36	0.50	ps
		50 kHz to 80 MHz (OC-192) ²	—	0.34	0.42	
Phase Jitter (RMS) for F _{OUT} of 10 to 160 MHz CMOS Output Only	ϕ _J	12 kHz to 20 MHz (OC-48) ²	—	0.62	—	ps
		50 kHz to 20 MHz ²	—	0.61	—	

Notes:

1. Refer to AN256 for further information.
2. Max offset frequencies: 80 MHz for F_{OUT} ≥ 250 MHz, 20 MHz for 50 MHz ≤ F_{OUT} <250 MHz, 2 MHz for 10 MHz ≤ F_{OUT} <50 MHz.

Table 6. CLK± Output Phase Jitter (Si571)

Parameter	Symbol	Test Condition	Min	Typ	Max	Units
Phase Jitter (RMS) ^{1,2,3} for $F_{OUT} \geq 500$ MHz	ϕ_J	Kv = 33 ppm/V				ps
		12 kHz to 20 MHz (OC-48)	—	0.26	—	
		50 kHz to 80 MHz (OC-192)	—	0.26	—	
		Kv = 45 ppm/V				
		12 kHz to 20 MHz (OC-48)	—	0.27	—	
		50 kHz to 80 MHz (OC-192)	—	0.26	—	
		Kv = 90 ppm/V				
		12 kHz to 20 MHz (OC-48)	—	0.32	—	
		50 kHz to 80 MHz (OC-192)	—	0.26	—	
		Kv = 135 ppm/V				
		12 kHz to 20 MHz (OC-48)	—	0.40	—	
		50 kHz to 80 MHz (OC-192)	—	0.27	—	
Kv = 180 ppm/V						
12 kHz to 20 MHz (OC-48)	—	0.49	—			
50 kHz to 80 MHz (OC-192)	—	0.28	—			
Kv = 356 ppm/V						
12 kHz to 20 MHz (OC-48)	—	0.87	—			
50 kHz to 80 MHz (OC-192)	—	0.33	—			

Notes:

1. Differential Modes: LVPECL/LVDS/CML. Refer to AN255, AN256, and AN266 for further information.
2. For best jitter and phase noise performance, always choose the smallest K_V that meets the application's minimum APR requirements. See "AN266: VCXO Tuning Slope (kV), Stability, and Absolute Pull Range (APR)" for more information.
3. See "AN255: Replacing 622 MHz VCXO devices with the Si550 VCXO" for comparison highlighting power supply rejection (PSR) advantage of Si55x versus SAW-based solutions.
4. Single ended mode: CMOS. Refer to the following application notes for further information:
 "AN255: Replacing 622 MHz VCXO Devices with the Si55x VCXO"
 "AN256: Integrated Phase Noise"
 "AN266: VCXO Tuning Slope (kV), Stability, and Absolute Pull Range (APR)"
5. Max offset frequencies: 80 MHz for $F_{OUT} \geq 250$ MHz, 20 MHz for $50 \text{ MHz} \leq F_{OUT} < 250$ MHz, 2 MHz for $10 \text{ MHz} \leq F_{OUT} < 50$ MHz.

Si570/Si571

Table 6. CLK± Output Phase Jitter (Si571) (Continued)

Parameter	Symbol	Test Condition	Min	Typ	Max	Units
Phase Jitter (RMS) ^{2,4,5} for F _{OUT} 10 to 160 MHz CMOS Output Only	ϕ_J	Kv = 33 ppm/V 12 kHz to 20 MHz (OC-48) 50 kHz to 20 MHz	— —	0.63 0.62	— —	ps
		Kv = 45 ppm/V 12 kHz to 20 MHz (OC-48) 50 kHz to 20 MHz	— —	0.63 0.62	— —	
		Kv = 90 ppm/V 12 kHz to 20 MHz (OC-48) 50 kHz to 20 MHz	— —	0.67 0.66	— —	
		Kv = 135 ppm/V 12 kHz to 20 MHz (OC-48) 50 kHz to 20 MHz	— —	0.74 0.72	— —	
		Kv = 180 ppm/V 12 kHz to 20 MHz (OC-48) 50 kHz to 20 MHz	— —	0.83 0.8	— —	
		Kv = 356 ppm/V 12 kHz to 20 MHz (OC-48) 50 kHz to 20 MHz	— —	1.26 1.2	— —	

Notes:

1. Differential Modes: LVPECL/LVDS/CML. Refer to AN255, AN256, and AN266 for further information.
2. For best jitter and phase noise performance, always choose the smallest K_V that meets the application's minimum APR requirements. See "AN266: VCXO Tuning Slope (kV), Stability, and Absolute Pull Range (APR)" for more information.
3. See "AN255: Replacing 622 MHz VCXO devices with the Si550 VCXO" for comparison highlighting power supply rejection (PSR) advantage of Si55x versus SAW-based solutions.
4. Single ended mode: CMOS. Refer to the following application notes for further information:
 "AN255: Replacing 622 MHz VCXO Devices with the Si55x VCXO"
 "AN256: Integrated Phase Noise"
 "AN266: VCXO Tuning Slope (kV), Stability, and Absolute Pull Range (APR)"
5. Max offset frequencies: 80 MHz for $F_{OUT} \geq 250$ MHz, 20 MHz for $50 \text{ MHz} \leq F_{OUT} < 250$ MHz, 2 MHz for $10 \text{ MHz} \leq F_{OUT} < 50$ MHz.

Table 6. CLK± Output Phase Jitter (Si571) (Continued)

Parameter	Symbol	Test Condition	Min	Typ	Max	Units
Phase Jitter (RMS) ^{1,2,3,5} for F _{OUT} of 125 to 500 MHz	ϕ_J	Kv = 33 ppm/V 12 kHz to 20 MHz (OC-48) 50 kHz to 80 MHz (OC-192)	— —	0.37 0.33	— —	ps
		Kv = 45 ppm/V 12 kHz to 20 MHz (OC-48) 50 kHz to 80 MHz (OC-192)	— —	0.37 0.33	— —	
		Kv = 90 ppm/V 12 kHz to 20 MHz (OC-48) 50 kHz to 80 MHz (OC-192)	— —	0.43 0.34	— —	
		Kv = 135 ppm/V 12 kHz to 20 MHz (OC-48) 50 kHz to 80 MHz (OC-192)	— —	0.50 0.34	— —	
		Kv = 180 ppm/V 12 kHz to 20 MHz (OC-48) 50 kHz to 80 MHz (OC-192)	— —	0.59 0.35	— —	
		Kv = 356 ppm/V 12 kHz to 20 MHz (OC-48) 50 kHz to 80 MHz (OC-192)	— —	1.00 0.39	— —	
Notes:						
1. Differential Modes: LVPECL/LVDS/CML. Refer to AN255, AN256, and AN266 for further information.						
2. For best jitter and phase noise performance, always choose the smallest K _V that meets the application's minimum APR requirements. See "AN266: VCXO Tuning Slope (kV), Stability, and Absolute Pull Range (APR)" for more information.						
3. See "AN255: Replacing 622 MHz VCXO devices with the Si550 VCXO" for comparison highlighting power supply rejection (PSR) advantage of Si55x versus SAW-based solutions.						
4. Single ended mode: CMOS. Refer to the following application notes for further information: "AN255: Replacing 622 MHz VCXO Devices with the Si55x VCXO" "AN256: Integrated Phase Noise" "AN266: VCXO Tuning Slope (kV), Stability, and Absolute Pull Range (APR)"						
5. Max offset frequencies: 80 MHz for F _{OUT} ≥ 250 MHz, 20 MHz for 50 MHz ≤ F _{OUT} < 250 MHz, 2 MHz for 10 MHz ≤ F _{OUT} < 50 MHz.						

Table 7. CLK± Output Period Jitter

Parameter	Symbol	Test Condition	Min	Typ	Max	Units
Period Jitter*	J _{PER}	RMS	—	2	—	ps
		Peak-to-Peak	—	14	—	
*Note: Any output mode, including CMOS, LVPECL, LVDS, CML. N = 1000 cycles. Refer to "AN279: Estimating Period Jitter from Phase Noise" for further information.						

Si570/Si571

Table 8. Typical CLK± Output Phase Noise (Si570)

Offset Frequency (f)	120.00 MHz LVDS	156.25 MHz LVPECL	622.08 MHz LVPECL	Units
100 Hz	-112	-105	-97	dBc/Hz
1 kHz	-122	-122	-107	
10 kHz	-132	-128	-116	
100 kHz	-137	-135	-121	
1 MHz	-144	-144	-134	
10 MHz	-150	-147	-146	
100 MHz	n/a	n/a	-148	

Table 9. Typical CLK± Output Phase Noise (Si571)

Offset Frequency (f)	74.25 MHz 90 ppm/V LVPECL	491.52 MHz 45 ppm/V LVPECL	622.08 MHz 135 ppm/V LVPECL	Units
100 Hz	-87	-75	-65	dBc/Hz
1 kHz	-114	-100	-90	
10 kHz	-132	-116	-109	
100 kHz	-142	-124	-121	
1 MHz	-148	-135	-134	
10 MHz	-150	-146	-146	
100 MHz	n/a	-147	-147	

Table 10. Absolute Maximum Ratings^{1,2}

Parameter	Symbol	Rating	Units
Supply Voltage, 1.8 V Option	V _{DD}	-0.5 to +1.9	V
Supply Voltage, 2.5/3.3 V Option	V _{DD}	-0.5 to +3.8	V
Input Voltage	V _I	-0.5 to V _{DD} + 0.3	V
Storage Temperature	T _S	-55 to +125	°C
ESD Sensitivity (HBM, per JESD22-A114)	ESD	>2000	V
Soldering Temperature (Lead-free Profile)	T _{PEAK}	260	°C
Soldering Temperature Time @ T _{PEAK} (Lead-free Profile)	t _p	20–40	seconds

Notes:

1. Stresses beyond the absolute maximum ratings may cause permanent damage to the device. Functional operation or specification compliance is not implied at these conditions.
2. The device is compliant with JEDEC J-STD-020. Refer to Si5xx Packaging FAQ available for download at www.silabs.com/VCXO for further information, including soldering profiles.

Table 11. Environmental Compliance

(The Si570/571 meets the following qualification test requirements.)

Parameter	Conditions/Test Method
Mechanical Shock	MIL-STD-883, Method 2002
Mechanical Vibration	MIL-STD-883, Method 2007
Solderability	MIL-STD-883, Method 2003
Gross and Fine Leak	MIL-STD-883, Method 1014
Resistance to Solder Heat	MIL-STD-883, Method 2036
Moisture Sensitivity Level	J-STD-020, MSL1
Contact Pads	Gold over Nickel

Table 12. Programming Constraints and Timing $(V_{DD} = 3.3\text{ V} \pm 10\%, T_A = -40\text{ to }85\text{ }^\circ\text{C})$

Parameter	Symbol	Test Condition	Min	Typ	Max	Unit
Output Frequency Range	CKO _F	HS_DIV x N1 >= 6	10	—	945	MHz
		HS_DIV x N1 = 5 N1 = 1	970	—	1134	MHz
		HS_DIV = 4 N1 = 1	1.2125	—	1.4175	GHz
Frequency Reprogramming Resolution	M _{RES}	114.285 MHz	—	0.09	—	ppb
Internal Oscillator Frequency	f _{OSC}		4850	—	5670	MHz
Internal Crystal Frequency Accuracy	f _{XTAL}	Maximum variation is ±2000 ppm	—	114.285	—	MHz
Delta Frequency for Continuous Output		From center frequency	-3500	—	+3500	ppm
Unfreeze to NewFreq Timeout					10	ms
Settling Time for Small Frequency Change		<±3500 ppm from center frequency	—	—	100	µs
Settling Time for Large Frequency Change		>±3500 ppm from center frequency after setting NewFreq bit	—	—	10	ms

3. Functional Description

The Si570 XO and the Si571 VCXO are low-jitter oscillators ideally suited for applications requiring programmable frequencies. The Si57x can be programmed to generate virtually any output clock in the range of 10 MHz to 1.4 GHz. Output jitter performance complies with and exceeds the strict requirements of high-speed communication systems including OC-192/STM-64 and 10 Gigabit Ethernet (10 GbE).

The Si57x consists of a digitally-controlled oscillator (DCO) based on Silicon Laboratories' third-generation DSPLL technology, which is driven by an internal fixed-frequency crystal reference.

The device's default output frequency is set at the factory and can be reprogrammed through the two-wire I²C serial port. Once the device is powered down, it will return to its factory-set default output frequency.

While the Si570 outputs a fixed frequency, the Si571 has a pullable output frequency using the voltage control input pin. This makes the Si571 an ideal choice for high-performance, low-jitter, phase-locked loops.

3.1. Programming a New Output Frequency

The output frequency (f_{out}) is determined by programming the DCO frequency (f_{DCO}) and the device's output dividers (HS_DIV, N1). The output frequency is calculated using the following equation:

$$f_{out} = \frac{f_{DCO}}{\text{Output Dividers}} = \frac{f_{XTAL} \times \text{RFREQ}}{\text{HSDIV} \times \text{N1}}$$

The DCO frequency is adjustable in the range of 4.85 to 5.67 GHz by setting the high-resolution 38-bit fractional multiplier (RFREQ). The DCO frequency is the product of the internal fixed-frequency crystal (f_{XTAL}) and RFREQ.

The 38-bit resolution of RFREQ allows the DCO frequency to have a programmable frequency resolution of 0.09 ppb.

As shown in Figure 3, the device allows reprogramming of the DCO frequency up to ± 3500 ppm from the center frequency configuration without interruption to the output clock. Changes greater than the ± 3500 ppm window will cause the device to recalibrate its internal tuning circuitry, forcing the output clock to momentarily stop and start at any arbitrary point during a clock cycle. This re-calibration process establishes a new center frequency and can take up to 10 ms. Circuitry receiving a clock from the Si57x device that is sensitive to glitches or runt pulses may have to be reset once the recalibration process is complete.

3.1.1. Reconfiguring the Output Clock for a Small Change in Frequency

For output changes less than ± 3500 ppm from the center frequency configuration, the DCO frequency is the only value that needs reprogramming. Since $f_{DCO} = f_{XTAL} \times \text{RFREQ}$, and that f_{XTAL} is fixed, changing the DCO frequency is as simple as reconfiguring the RFREQ value as outlined below:

1. Using the serial port, read the current RFREQ value (addresses 7–12 for all Si571 devices and Si570 devices with 20 ppm and 50 ppm temperature stability; or addresses 13–18 for Si570 devices with 7 ppm temperature stability).
2. Calculate the new value of RFREQ given the change in frequency.

$$\text{RFREQ}_{\text{new}} = \text{RFREQ}_{\text{current}} \times \frac{f_{\text{out_new}}}{f_{\text{out_current}}}$$

3. Using the serial port, write the new RFREQ value (addresses 7–12 for all Si571 devices and Si570 devices with 20 ppm and 50 ppm temperature stability; or addresses 13–18 for Si570 devices with 7 ppm temperature stability).

Example:

An Si570 generating a 148.35 MHz clock must be reconfigured "on-the-fly" to generate a 148.5 MHz clock. This represents a change of +1011.122 ppm, which is well within the ± 3500 ppm window.

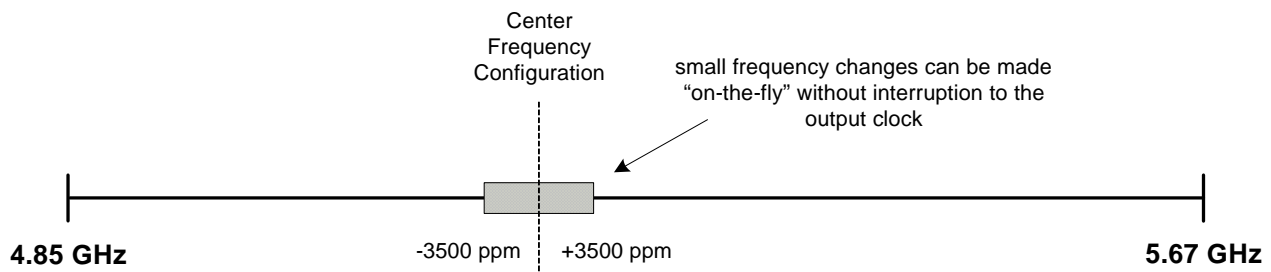

Figure 3. DCO Frequency Range

A typical frequency configuration for this example:

RFREQ_{current} = 0x2EBB04CE0

F_{out_current} = 148.35 MHz

F_{out_new} = 148.50 MHz

Calculate RFREQ_{new} to change the output frequency from 148.35 MHz to 148.5 MHz:

$$\begin{aligned} \text{RFREQ}_{\text{new}} &= 0x2EBB04CE0 \times \frac{148.50 \text{ MHz}}{148.35 \text{ MHz}} \\ &= 0x2EC71D666 \end{aligned}$$

Note: Performing calculations with RFREQ requires a minimum of 38-bit arithmetic precision.

Even relatively small changes in output frequency may require writing more than 1 RFREQ register. Such multi-register RFREQ writes can impact the output clock frequency on a register-by-register basis during updating.

Interim changes to the output clock during RFREQ writes can be prevented by using the following procedure:

1. Freeze the “M” value (Set Register 135 bit 5 = 1).
2. Write the new frequency configuration (RFREQ).
3. Unfreeze the “M” value (Set Register 135 bit 5 = 0)

3.1.2. Reconfiguring the Output Clock for Large Changes in Output Frequency

For output frequency changes outside of ± 3500 ppm from the center frequency, it is likely that both the DCO frequency and the output dividers need to be reprogrammed. Note that changing the DCO frequency outside of the ± 3500 ppm window will cause the output to momentarily stop and restart at any arbitrary point in a clock cycle. Devices sensitive to glitches or runt pulses may have to be reset once reconfiguration is complete.

The process for reconfiguring the output frequency outside of a ± 3500 ppm window first requires reading the current RFREQ, HSDIV, and N1 values. Next, calculate f_{XTAL} for the device. Note that, due to slight variations of the internal crystal frequency from one device to another, each device may have a different RFREQ value or possibly even different HSDIV or N1 values to maintain the same output frequency. It is necessary to calculate f_{XTAL} for each device. Third, write the new values back to the device using the appropriate registers (addresses 7–12 for all Si571 devices and Si570 devices with 20 ppm and 50 ppm temperature stability; or addresses 13–18 for Si570 devices with 7 ppm temperature stability) sequencing as described in “3.1.2.1. Writing the New Frequency Configuration”.

$$f_{\text{XTAL}} = \frac{F_{\text{out}} \times \text{HSDIV} \times N1}{\text{RFREQ}}$$

Once f_{XTAL} has been determined, new values for RFREQ, HSDIV, and N1 are calculated to generate a new output frequency ($f_{\text{out_new}}$). New values can be calculated manually or with the Si57x-EVB software, which provides a user-friendly application to help find the optimum values.

The first step in manually calculating the frequency configuration is to determine new frequency divider values (HSDIV, N1). Given the desired output frequency ($f_{\text{out_new}}$), find the frequency divider values that will keep the DCO oscillation frequency in the range of 4.85 to 5.67 GHz.

$$f_{\text{DCO_new}} = f_{\text{out_new}} \times \text{HSDIV}_{\text{new}} \times N1_{\text{new}}$$

Valid values of HSDIV are 4, 5, 6, 7, 9 or 11. N1 can be selected as 1 or any even number up to 128 (i.e. 1, 2, 4, 6, 8, 10 ... 128). To help minimize the device's power consumption, the divider values should be selected to keep the DCO's oscillation frequency as low as possible. The lowest value of N1 with the highest value of HS_DIV also results in the best power savings.

Once HS_DIV and N1 have been determined, the next step is to calculate the reference frequency multiplier (RFREQ).

$$\text{RFREQ}_{\text{new}} = \frac{f_{\text{DCO_new}}}{f_{\text{XTAL}}}$$

RFREQ is programmable as a 38-bit binary fractional frequency multiplier with the first 10 most significant bits (MSBs) representing the integer portion of the multiplier, and the 28 least significant bits (LSBs) representing the fractional portion.

Before entering a fractional number into the RFREQ register, it must be converted to a 38-bit integer using a bitwise left shift operation by 28 bits, which effectively multiplies RFREQ by 2^{28} .

Example:

RFREQ = 46.043042064d

Multiply RFREQ by $2^{28} = 12359584992.1$

Discard the fractional portion = 12359584992

Convert to hexadecimal = 02E0B04CE0h

In the example above, the multiplication operation requires 38-bit precision. If 38-bit arithmetic precision is not available, then the fractional portion can be separated from the integer and shifted to the left by 28-bits. The result is concatenated with the integer portion to form a full 38-bit word. An example of this operation is shown in Figure 4.

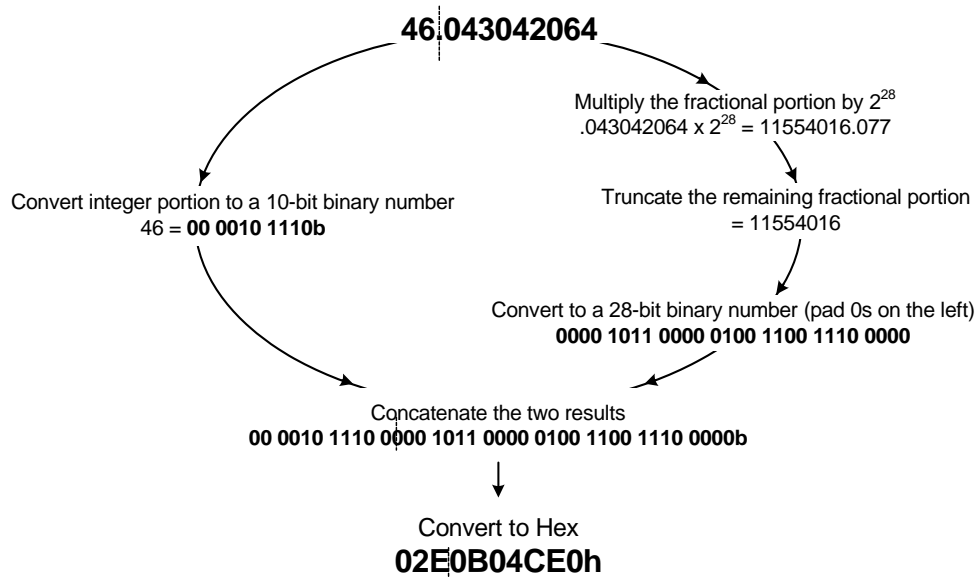

Figure 4. Example of RFREQ Decimal to Hexadecimal Conversion

3.1.2.1. Writing the New Frequency Configuration

Once the new values for RFREQ, HSDIV, and N1 are determined, they can be written directly into the device from the serial port using the following procedure:

1. Freeze the DCO (bit 4 of Register 137)
2. Write the new frequency configuration (RFREQ, HSDIV, and N1) to addresses 7–12 for all Si571 devices and Si570 devices with 20 ppm and 50 ppm temperature stability; or addresses 13–18 for Si570 devices with 7 ppm temperature stability.
3. Unfreeze the DCO and assert the NewFreq bit (bit 6 of Register 135) within the maximum Unfreeze to NewFreq Timeout specified in Table 12, “Programming Constraints and Timing,” on page 13.

The process of freezing and unfreezing the DCO will cause the output clock to momentarily stop and start at any arbitrary point during a clock cycle. This process can take up to 10 ms. Circuitry that is sensitive to glitches or runt pulses may have to be reset after the new frequency configuration is written.

Example:

An Si570 generating 156.25 MHz must be re-configured to generate a 161.1328125 MHz clock (156.25 MHz x 66/64). This frequency change is greater than ±3500 ppm.

$$f_{\text{out}} = 156.25 \text{ MHz}$$

Read the current values for RFREQ, HS_DIV, N1:

$$\text{RFREQ}_{\text{current}} = 0x2BC011EB8h = 11744124600d,$$

$$11744124600d \times 2^{28} = 43.7502734363d$$

$$\text{HS_DIV} = 4$$

$$\text{N1} = 8$$

Calculate f_{XTAL} , $f_{\text{DCO_current}}$

$$f_{\text{DCO_current}} = f_{\text{out}} \times \text{HSDV} \times \text{N1} = 5.000000000 \text{ GHz}$$

$$f_{\text{XTAL}} = \frac{f_{\text{DCO_current}}}{\text{RFREQ}_{\text{current}}} = 114.285 \text{ MHz}$$

Given $f_{\text{out_new}} = 161.1328125 \text{ MHz}$, choose output dividers that will keep f_{DCO} within the range of 4.85 to 5.67 GHz. In this case, keeping the same output dividers will still keep f_{DCO} within its range limits:

$$\begin{aligned} f_{\text{DCO_new}} &= f_{\text{out_new}} \times \text{HSDV}_{\text{new}} \times \text{N1}_{\text{new}} \\ &= 161.1328125 \text{ MHz} \times 4 \times 8 = 5.156250000 \text{ GHz} \end{aligned}$$

Calculate the new value of RFREQ given the new DCO frequency:

$$\begin{aligned} \text{RFREQ}_{\text{new}} &= \frac{f_{\text{DCO_new}}}{f_{\text{XTAL}}} = 45.11746948 \\ &= 0x2D1E127AD \end{aligned}$$

3.2. I²C Interface

The control interface to the Si570 is an I²C-compatible 2-wire bus for bidirectional communication. The bus consists of a bidirectional serial data line (SDA) and a serial clock input (SCL). Both lines must be connected to the positive supply via an external pullup. Fast mode operation is supported for transfer rates up to 400 kbps as specified in the I²C-Bus Specification standard.

Figure 5 shows the command format for both read and write access. Data is always sent MSB. Data length is 1 byte. Read and write commands support 1 or more data bytes as illustrated. The master must send a Not Acknowledge and a Stop after the last read data byte to terminate the read command. The timing specifications and timing diagram for the I²C bus can be found in the I²C-Bus Specification standard (fast mode operation). The device I²C address is specified in the part number.

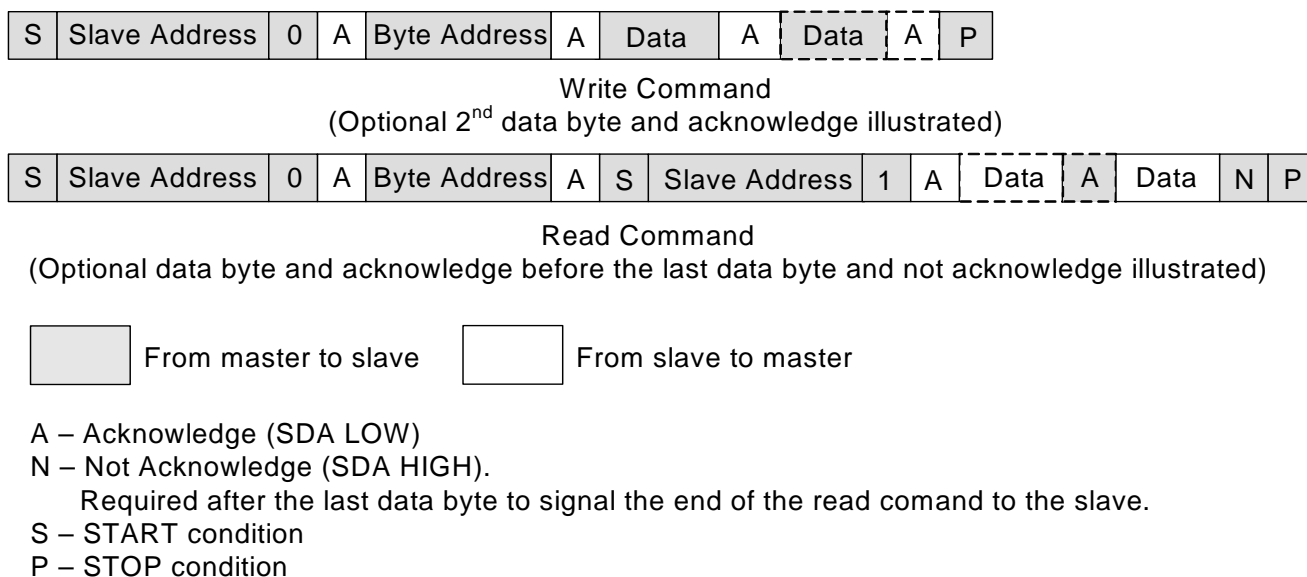

Figure 5. I²C Command Format

Si570/Si571

4. Serial Port Registers

Note: Any register not listed here is reserved and must not be written. All bits are R/W unless otherwise noted.

Register	Name	Bit 7	Bit 6	Bit 5	Bit 4	Bit 3	Bit 2	Bit 1	Bit 0
7	High Speed/ N1 Dividers	HS_DIV[2:0]			N1[6:2]				
8	Reference Frequency	N1[1:0]		RFREQ[37:32]					
9	Reference Frequency	RFREQ[31:24]							
10	Reference Frequency	RFREQ[23:16]							
11	Reference Frequency	RFREQ[15:8]							
12	Reference Frequency	RFREQ[7:0]							
13	High Speed/ N1 Dividers	HS_DIV_7PPM[2:0]			N1_7PPM[6:2]				
14	Reference Frequency	N1_7PPM[1:0]		RFREQ_7PPM[37:32]					
15	Reference Frequency	RFREQ_7PPM[31:24]							
16	Reference Frequency	RFREQ_7PPM[23:16]							
17	Reference Frequency	RFREQ_7PPM[15:8]							
18	Reference Frequency	RFREQ_7PPM[7:0]							
135	Reset/Freeze/ Memory Control	RST_REG	NewFreq	Freeze M	Freeze VCADC				RECALL
137	Freeze DCO				Freeze DCO				

Register 7. High Speed/N1 Dividers

Bit	D7	D6	D5	D4	D3	D2	D1	D0
Name	HS_DIV[2:0]			N1[6:2]				
Type	R/W			R/W				

Bit	Name	Function
7:5	HS_DIV[2:0]	<p>DCO High Speed Divider. Sets value for high speed divider that takes the DCO output f_{OSC} as its clock input.</p> <p>000 = 4 001 = 5 010 = 6 011 = 7 100 = Not used. 101 = 9 110 = Not used. 111 = 11</p>
4:0	N1[6:2]	<p>CLKOUT Output Divider. Sets value for CLKOUT output divider. Allowed values are [1] and [2, 4, 6, ..., 2^7]. Illegal odd divider values will be rounded up to the nearest even value. The value for the N1 register can be calculated by taking the divider ratio minus one. For example, to divide by 10, write 0001001 (9 decimal) to the N1 registers.</p> <p>0000000 = 1 1111111 = 2^7</p>

Register 8. Reference Frequency

Bit	D7	D6	D5	D4	D3	D2	D1	D0
Name	N1[1:0]		RFREQ[37:32]					
Type	R/W		R/W					

Bit	Name	Function
7:6	N1[1:0]	<p>CLKOUT Output Divider. Sets value for CLKOUT output divider. Allowed values are [1, 2, 4, 6, ..., 2^7]. Illegal odd divider values will be rounded up to the nearest even value. The value for the N1 register can be calculated by taking the divider ratio minus one. For example, to divide by 10, write 0001001 (9 decimal) to the N1 registers.</p> <p>0000000 = 1 1111111 = 2^7</p>
5:0	RFREQ[37:32]	<p>Reference Frequency. Frequency control input to DCO.</p>

Si570/Si571

Register 9. Reference Frequency

Bit	D7	D6	D5	D4	D3	D2	D1	D0
Name	RFREQ[31:24]							
Type	R/W							

Bit	Name	Function
7:0	RFREQ[31:24]	Reference Frequency. Frequency control input to DCO.

Register 10. Reference Frequency

Bit	D7	D6	D5	D4	D3	D2	D1	D0
Name	RFREQ[23:16]							
Type	R/W							

Bit	Name	Function
7:0	RFREQ[23:16]	Reference Frequency. Frequency control input to DCO.

Register 11. Reference Frequency

Bit	D7	D6	D5	D4	D3	D2	D1	D0
Name	RFREQ[15:8]							
Type	R/W							

Bit	Name	Function
7:0	RFREQ[15:8]	Reference Frequency. Frequency control input to DCO.

Register 12. Reference Frequency

Bit	D7	D6	D5	D4	D3	D2	D1	D0
Name	RFREQ[7:0]							
Type	R/W							

Bit	Name	Function
7:0	RFREQ[7:0]	Reference Frequency. Frequency control input to DCO.

Register 13. High Speed/N1 Dividers

Bit	D7	D6	D5	D4	D3	D2	D1	D0
Name	HS_DIV_7PPM[2:0]			N1_7PPM[6:2]				
Type	R/W				R/W			

Bit	Name	Function
7:5	HS_DIV_7PPM[2:0]	DCO High Speed Divider. Sets value for high speed divider that takes the DCO output f_{OSC} as its clock input. 000 = 4 001 = 5 010 = 6 011 = 7 100 = Not used. 101 = 9 110 = Not used. 111 = 11
4:0	N1_7PPM[6:2]	CLKOUT Output Divider. Sets value for CLKOUT output divider. Allowed values are [1] and [2, 4, 6, ..., 2^7]. Illegal odd divider values will be rounded up to the nearest even value. The value for the N1 register can be calculated by taking the divider ratio minus one. For example, to divide by 10, write 0001001 (9 decimal) to the N1 registers. 0000000 = 1 1111111 = 2^7

Si570/Si571

Register 14. Reference Frequency

Bit	D7	D6	D5	D4	D3	D2	D1	D0
Name	N1_7PPM[1:0]		RFREQ_7PPM[37:32]					
Type	R/W			R/W				

Bit	Name	Function
7:6	N1_7PPM[1:0]	CLKOUT Output Divider. Sets value for CLKOUT output divider. Allowed values are [1, 2, 4, 6, ..., 2 ⁷]. Illegal odd divider values will be rounded up to the nearest even value. The value for the N1 register can be calculated by taking the divider ratio minus one. For example, to divide by 10, write 0001001 (9 decimal) to the N1 registers. 0000000 = 1 1111111 = 2 ⁷
5:0	RFREQ_7PPM[37:32]	Reference Frequency. Frequency control input to DCO.

Register 15. Reference Frequency

Bit	D7	D6	D5	D4	D3	D2	D1	D0
Name	RFREQ_7PPM[31:24]							
Type	R/W							

Bit	Name	Function
7:0	RFREQ_7PPM[31:24]	Reference Frequency. Frequency control input to DCO.

Register 16. Reference Frequency

Bit	D7	D6	D5	D4	D3	D2	D1	D0
Name	RFREQ_7PPM[23:16]							
Type	R/W							

Bit	Name	Function
7:0	RFREQ_7PPM[23:16]	Reference Frequency. Frequency control input to DCO.

Register 17. Reference Frequency

Bit	D7	D6	D5	D4	D3	D2	D1	D0
Name	RFREQ_7PPM[15:8]							
Type	R/W							

Bit	Name	Function
7:0	RFREQ_7PPM[15:8]	Reference Frequency. Frequency control input to DCO.

Register 18. Reference Frequency

Bit	D7	D6	D5	D4	D3	D2	D1	D0
Name	RFREQ_7PPM[7:0]							
Type	R/W							

Bit	Name	Function
7:0	RFREQ_7PPM[7:0]	Reference Frequency. Frequency control input to DCO.

Si570/Si571

Register 135. Reset/Freeze/Memory Control

Bit	D7	D6	D5	D4	D3	D2	D1	D0
Name	RST_REG	NewFreq	Freeze M	Freeze VCADC		N/A		RECALL
Type	R/W	R/W	R/W	R/W		R/W		R/W

Reset settings = 00xx xx00

Bit	Name	Function
7	RST_REG	Internal Reset. 0 = Normal operation. 1 = Reset of all internal logic. Output tristated during reset. Upon completion of internal logic reset, RST_REG is internally reset to zero. Note: Asserting RST_REG will interrupt the I ² C state machine. It is not the recommended approach for starting from initial conditions.
6	NewFreq	New Frequency Applied. Alerts the DSPLL that a new frequency configuration has been applied. This bit will clear itself when the new frequency is applied.
5	Freeze M	Freezes the M Control Word. Prevents interim frequency changes when writing RFREQ registers.
4	Freeze VCADC	Freezes the VC ADC Output Word. May be used to hold the nominal output frequency of an Si571.
3:1	N/A	Always Zero.
0	RECALL	Recall NVM into RAM. 0 = No operation. 1 = Write NVM bits into RAM. Bit is internally reset following completion of operation. Note: Asserting RECALL reloads the NVM contents in to the operating registers without interrupting the I ² C state machine. It is the recommended approach for starting from initial conditions.

Register 137. Freeze DCO

Bit	D7	D6	D5	D4	D3	D2	D1	D0
Name				Freeze DCO				
Type	R/W							

Reset settings = 00xx xx00

Bit	Name	Function
7:5	Reserved	
4	Freeze DCO	Freeze DCO. Freezes the DSPLL so the frequency configuration can be modified.
3:0	Reserved	

5. Si570 (XO) Pin Descriptions

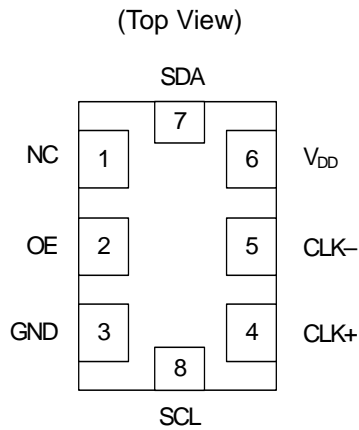

Table 13. Si570 Pin Descriptions

Pin	Name	Type	Function
1	NC	N/A	No Connect. Make no external connection to this pin.
2	OE	Input	Output Enable: See "7. Ordering Information" on page 27.
3	GND	Ground	Electrical and Case Ground.
4	CLK+	Output	Oscillator Output.
5	CLK- (NC for CMOS*)	Output (N/A for CMOS*)	Complementary Output. (NC for CMOS*).
6	V _{DD}	Power	Power Supply Voltage.
7	SDA	Bidirectional Open Drain	I ² C Serial Data.
8	SCL	Input	I ² C Serial Clock.

***Note:** CMOS output option only: make no external connection to this pin.

Si570/Si571

6. Si571 (VCXO) Pin Descriptions

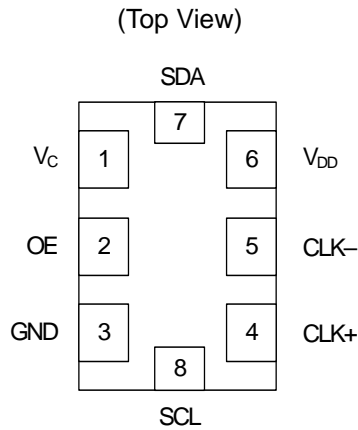

Table 14. Si571 Pin Descriptions

Pin	Name	Type	Function
1	V _C	Analog Input	Control Voltage
2	OE	Input	Output Enable: See "7. Ordering Information" on page 27.
3	GND	Ground	Electrical and Case Ground
4	CLK+	Output	Oscillator Output
5	CLK- (NC for CMOS*)	Output (N/A for CMOS*)	Complementary Output. (NC for CMOS*).
6	V _{DD}	Power	Power Supply Voltage
7	SDA	Bidirectional Open Drain	I ² C Serial Data
8	SCL	Input	I ² C Serial Clock

***Note:** CMOS output option only: make no external connection to this pin.

7. Ordering Information

The Si570/Si571 supports a wide variety of options including frequency range, start-up frequency, temperature stability, tuning slope, output format, and V_{DD} . Specific device configurations are programmed into the Si570/Si571 at time of shipment. Configurations are specified using the Part Number Configuration chart shown below. Silicon Labs provides a web browser-based part number configuration utility to simplify this process. Refer to www.silabs.com/VCXOPartNumber to access this tool and for further ordering instructions. The Si570/Si571 XO/VCXO series is supplied in an industry-standard, RoHS compliant, 8-pad, 5 x 7 mm package. Tape and reel packaging is an ordering option.

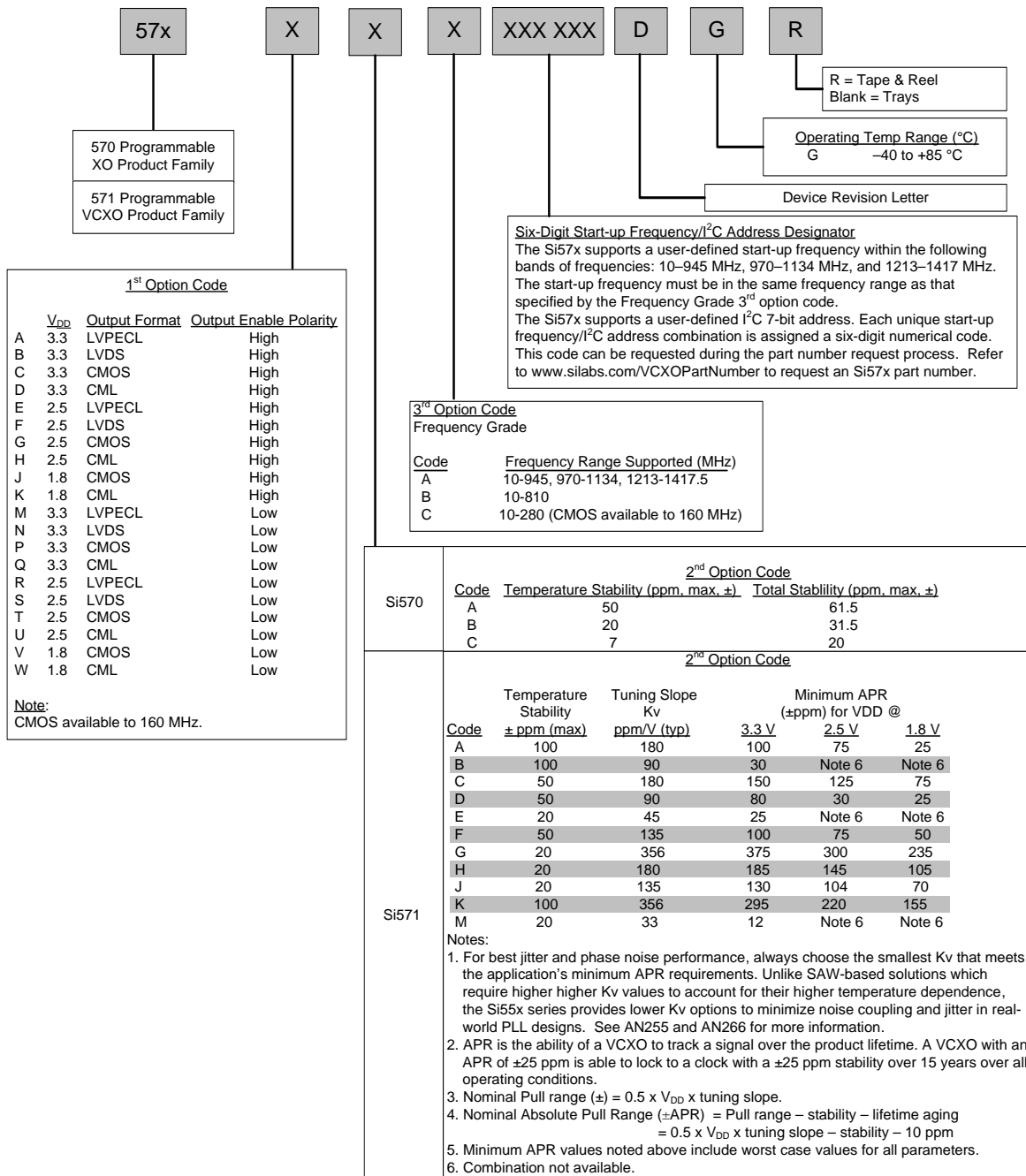

Figure 6. Part Number Convention

8. Si57x Mark Specification

Figure 7 illustrates the mark specification for the Si57x. Table 15 lists the line information.

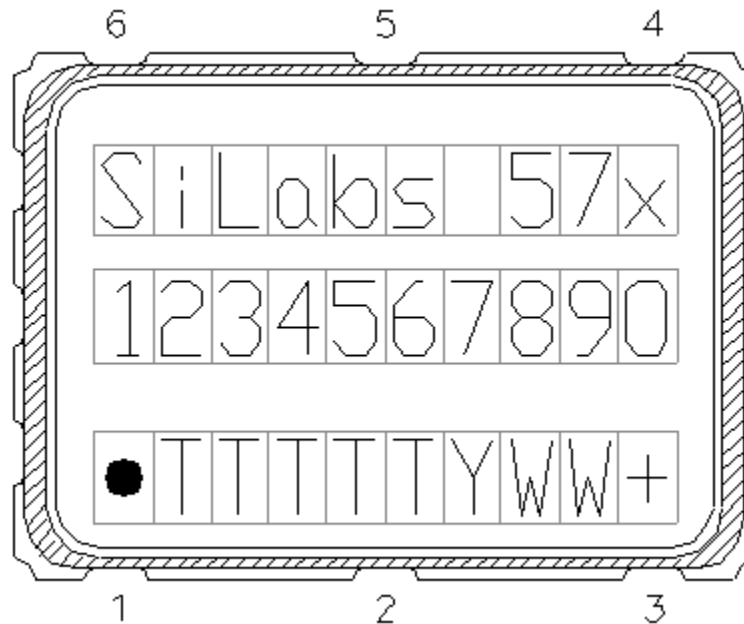

Figure 7. Mark Specification

Table 15. Si57x Top Mark Description

Line	Position	Description
1	1–10	“SiLabs”+ Part Family Number, 57x (First 3 characters in part number where x = 0 indicates a 570 device and x = 1 indicates a 571 device)
2	1–10	Si570, Si571: Option1 + Option2 + Option3 + ConfigNum(6) + Temp
3	Trace Code	
	Position 1	Pin 1 orientation mark (dot)
	Position 2	Product Revision (D)
	Position 3–6	Tiny Trace Code (4 alphanumeric characters per assembly release instructions)
	Position 7	Year (least significant year digit), to be assigned by assembly site (ex: 2007 = 7)
	Position 8–9	Calendar Work Week number (1–53), to be assigned by assembly site
	Position 10	“+” to indicate Pb-Free and RoHS-compliant

9. Outline Diagram and Suggested Pad Layout

Figure 8 illustrates the package details for the Si570/Si571. Table 16 lists the values for the dimensions shown in the illustration.

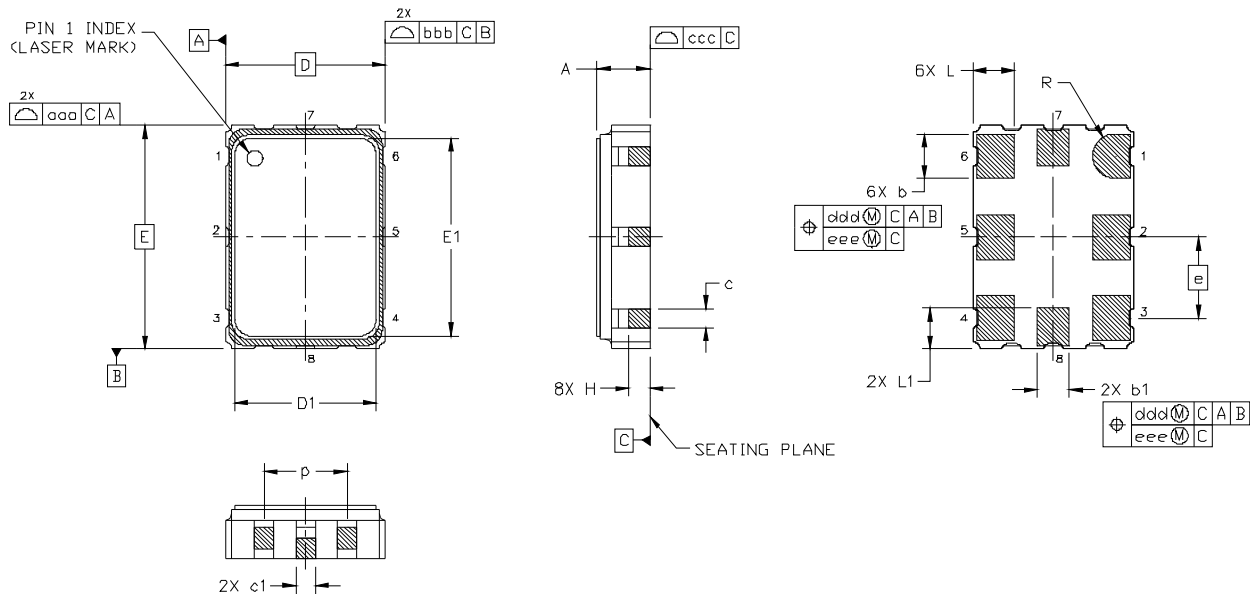

Figure 8. Si570/Si571 Outline Diagram

Table 16. Package Diagram Dimensions (mm)

Dimension	Min	Nom	Max
A	1.50	1.65	1.80
b	1.30	1.40	1.50
b1	0.90	1.00	1.10
c	0.50	0.60	0.70
c1	0.30	—	0.60
D	5.00 BSC		
D1	4.30	4.40	4.50
e	2.54 BSC		
E	7.00 BSC		
E1	6.10	6.20	6.30
H	0.55	0.65	0.75
L	1.17	1.27	1.37
L1	1.07	1.17	1.27
p	1.80	—	2.60
R	0.70 REF		
aaa	—	—	0.15
bbb	—	—	0.15
ccc	—	—	0.10
ddd	—	—	0.10
eee	—	—	0.05

Note:

- All dimensions shown are in millimeters (mm) unless otherwise noted.
- Dimensioning and Tolerancing per ANSI Y14.5M-1994.

10. 8-Pin PCB Land Pattern

Figure 9 illustrates the 8-pin PCB land pattern for the Si570/Si571. Table 17 lists the values for the dimensions shown in the illustration.

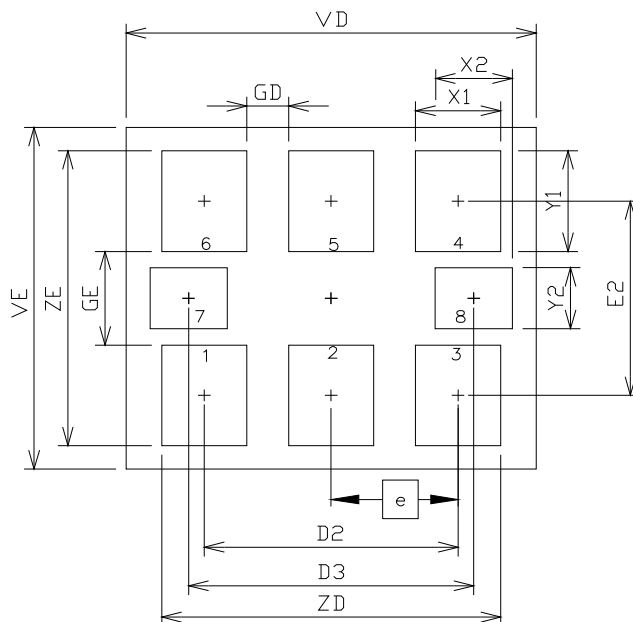

Figure 9. Si570/Si571 PCB Land Pattern

Table 17. PCB Land Pattern Dimensions (mm)

Dimension	Min	Max
D2	5.08 REF	
D3	5.705 REF	
e	2.54 BSC	
E2	4.20 REF	
GD	0.84	—
GE	2.00	—
VD	8.20 REF	
VE	7.30 REF	
X1	1.70 TYP	
X2	1.545 TYP	
Y1	2.15 REF	
Y2	1.3 REF	
ZD	—	6.78
ZE	—	6.30

Note:

1. Dimensioning and tolerancing per the ANSI Y14.5M-1994 specification.
2. Land pattern design follows IPC-7351 guidelines.
3. All dimensions shown are at maximum material condition (MMC).
4. Controlling dimension is in millimeters (mm).

DOCUMENT CHANGE LIST

Revision 1.0 to Revision 1.1

- Restored programming constraint information on page 15 and in Table 12, page 12.
- Clarified NC (No Connect) pin designations in Tables 13–14 on pages 22–23.

Revision 1.1 to Revision 1.2

- Replaced “Unfreeze to Newfreq Delay” with the clearer terminology “Unfreeze to Newfreq Timeout” on page 15 and in Table 12 on page 13.
- Added Freeze M procedure on page 14 for preventing output clock changes during small frequency change multi-register RFREQ writes.
- Added Freeze M, Freeze VCADC, and RST_REG versus RECALL information to Register 135 references in “4. Serial Port Registers” on pages 17 and 20.
- Added Si570 20 ppm Total Stability Ordering Option to Figure 6 on page 27.
- Updated Figure 8 and Table 16 on page 29 to include production test sidepads. This change is for reference only as the sidepads are raised above the seating plane and do not impact PCB layout.
- Corrected errors in Table 11 on page 13.

Revision 1.2 to Revision 1.3

- Updated Table 3 on page 6 to include 7 ppm temperature stability and 20 ppm to stability parameters. Also changed aging test condition (frequency drift over life) from 15 years to 20 years.
- Updated 2.5 V/3.3 V and 1.8 V CML output level specification for Table 4 on page 7.
- Added footnotes clarifying max offset frequency test conditions in Table 5 on page 8.
- Updated ESD HBM sensitivity rating and the JEDEC standard in Note 2 in Table 10 on page 12.
- Updated Table 11 on page 13 to include “Moisture Sensitivity Level” and “Contact Pads” rows.
- Added Si570 7 ppm Total Stability Ordering Option to Figure 6 on page 27.
- Updated Figure 7 and Table 15 on page 28 to reflect specific marking information. Previously, Figure 7 was generic.
- Clarified “3.1.2. Reconfiguring the Output Clock for Large Changes in Output Frequency” on page 15 and added new registers 13-18 in “4. Serial Port Registers” on page 18 for the Si570 7 ppm temperature stability / 20 ppm total stability ordering option.
- Added text to “3. Functional Description” on page 14, paragraph 1, to state that the total output jitter complies to and exceeds strict requirements of various high-speed communication systems.

CONTACT INFORMATION

Silicon Laboratories Inc.

400 West Cesar Chavez
Austin, TX 78701
Tel: 1+(512) 416-8500
Fax: 1+(512) 416-9669
Toll Free: 1+(877) 444-3032

Please visit the Silicon Labs Technical Support web page:
<https://www.silabs.com/support/pages/contacttechnicalsupport.aspx>
and register to submit a technical support request.

The information in this document is believed to be accurate in all respects at the time of publication but is subject to change without notice. Silicon Laboratories assumes no responsibility for errors and omissions, and disclaims responsibility for any consequences resulting from the use of information included herein. Additionally, Silicon Laboratories assumes no responsibility for the functioning of undescribed features or parameters. Silicon Laboratories reserves the right to make changes without further notice. Silicon Laboratories makes no warranty, representation or guarantee regarding the suitability of its products for any particular purpose, nor does Silicon Laboratories assume any liability arising out of the application or use of any product or circuit, and specifically disclaims any and all liability, including without limitation consequential or incidental damages. Silicon Laboratories products are not designed, intended, or authorized for use in applications intended to support or sustain life, or for any other application in which the failure of the Silicon Laboratories product could create a situation where personal injury or death may occur. Should Buyer purchase or use Silicon Laboratories products for any such unintended or unauthorized application, Buyer shall indemnify and hold Silicon Laboratories harmless against all claims and damages.

Silicon Laboratories and Silicon Labs are trademarks of Silicon Laboratories Inc.
Other products or brandnames mentioned herein are trademarks or registered trademarks of their respective holders.