

**Harvatek Surface Mount LED Data Sheet
HT-358 Series**

Official Product	Product: HT-358 Series			Data Sheet No.
Tentative Product	*****			HT-358 Series
Specifications are subject to change without notice. Data and drawings herein are copyrighted.		Mar 30, 2006	Version of 1.2	Page 1/22

DISCLAIMER	3
PRODUCT SPECIFICATIONS	4
ATTENTION: ELECTROSTATIC DISCHARGE (ESD) PROTECTION	5
LABEL SPECIFICATIONS	6
PRODUCT CHARACTERISTICS	10
ABSOLUTE MAXIMUM RATINGS	10
ELECTRO-OPTICAL CHARACTERISTICS	10
PACKAGE OUTLINE DIMENSION	11
RECOMMENDED SOLDERING PATTERN FOR REFLOW SOLDERING	11
CHARACTERISTIC CURVES FOR UD (ULTRA BRIGHT AMBER) AND USD (ULTRA BRIGHT RED)	12
CHARACTERISTIC CURVES FOR NB (BLUE) AND NG (TRUE GREEN)	13
CHARACTERISTIC CURVES FOR ALL COLORS (RADIATION PATTERN)	14
PACKAGING	15
TAPE DIMENSION	15
REEL DIMENSION	16
PACKING	17
DRY PACK	18
REFLOW SOLDERING	19
PRECAUTIONS	20
REWORKING	20
CLEANING	20
RELIABILITY	21
REVISION HISTORY	22

Official Product	Product: HT-358 Series		Data Sheet No.
Tentative Product	*****		HT-358 Series
Specifications are subject to change without notice. Data and drawings herein are copyrighted.	Mar 30, 2006	Version of 1.2	Page 2/22

DISCLAIMER

HARVATEK reserves the right to make changes without further notice to any products herein to improve reliability, function or design. HARVATEK does not assume any liability arising out of the application or use of any product or circuit described herein; neither does it convey any license under its patent rights, nor the rights of others.

LIFE SUPPORT POLICY

HARVATEK's products are not authorized for use as critical components in life support devices or systems without the express written approval of the President of HARVATEK or HARVATEK INTERNATIONAL. As used herein:

1. Life support devices or systems are devices or systems which, (a) are intended for surgical implant into the body, or (b) support or sustain life, and (c) whose failure to perform when properly used in accordance with instructions for use provided in the labeling, can be reasonably expected to result in a significant injury of the user.
2. A critical component in any component of a life support device or system whose failure to perform can be reasonably expected to cause the failure of the life support device or system, or to affect its safety or effectiveness.

Official Product	Product: HT-358 Series			Data Sheet No.
Tentative Product	*****			HT-358 Series
Specifications are subject to change without notice. Data and drawings herein are copyrighted.		Mar 30, 2006	Version of 1.2	Page 3/22

Product Specifications

Product	Emission Color	Technology	Test Current I_F (mA)	Luminous Intensity I_V (mcd)	Forward Voltage V_F (V)	Orderable Part Number
HT-358FCH	Ultra Bright Red	AlInGaP	20	140 typ	1.9 typ	HT-358FCH-ZZZZ
	True Green	InGaN	20	200 typ	3.3 typ	
	Blue	InGaN	20	90 typ	3.3 typ	
HT-358FDH	Ultra Bright Amber	AlInGaP	20	140 typ	1.9 typ	HT-358FDH-ZZZZ
	True Green	InGaN	20	200 typ	3.3 typ	
	Blue	InGaN	20	90 typ	3.3 typ	

Official Product	Product: HT-358 Series		Data Sheet No.
Tentative Product	*****		HT-358 Series
Specifications are subject to change without notice. Data and drawings herein are copyrighted.		Mar 30, 2006	Version of 1.2
			Page 4/22

	Specification	Material	Quantity
Resin	Water clear	Epoxy resin	
Carrier tape	Per EIA 481-1A specs	Conductive black tape	3000pcs per reel
Reel	Per EIA 481-1A specs	Conductive black	
Label	HT standard	Paper	
Packing bag	220x240mm	Aluminum laminated bag/ no-zipper	One reel per bag
Carton	HT standard	Paper	

Others:

Each immediate box consists of 5 reels. The 5 reels may not necessarily have the same lot number or the same bin combinations of I_v , λ_D and V_f . Each reel has a label identifying its specification; the immediate box consists of a product label as well.

ATTENTION: Electrostatic Discharge (ESD) protection



The symbol to the left denotes that ESD precaution is needed. ESD protection for GaP and AlGaAs based chips is necessary even though they are relatively safe in the presence of low static-electric discharge. Parts built with AlInGaP, GaN, or/and InGaN based chips are **STATIC SENSITIVE devices**. ESD precaution must be taken during design and assembly.

If manual work or processing is needed, please ensure the device is adequately protected from ESD during the process.

Official Product	Product: HT-358 Series			Data Sheet No.
Tentative Product	*****			HT-358 Series
Specifications are subject to change without notice. Data and drawings herein are copyrighted.		Mar 30, 2006	Version of 1.2	Page 5/22

Label Specifications

HARVATEK		Date: yyyy/mm/dd
CUSTOMER P/N: 		
HARVATEK P/N: 	QTY: PCS 	
LOT NO: 		QC
IV BIN: COLOR BIN: VF:		

Harvatek P/N:

H T - 3 5 8 X X X - Z Z Z Z

Series Name	Emitting Color	Customer Code
HT-358 HT: Harvatek 358: 1210 reflector series 3.2 (L) x 2.7 (W) x 1.1 (H) mm	XXX FCH: Full Color Ultra Bright Red True Green Blue FDH: Full Color Ultra Bright Amber True Green Blue	ZZZZ Customer Product Code (TBD)

Official Product	Product: HT-358 Series			Data Sheet No.
Tentative Product	*****			HT-358 Series
Specifications are subject to change without notice. Data and drawings herein are copyrighted.	Mar 30, 2006	Version of 1.2	Page 6/22	

Lot No.:

1 2 3 4 5 6 7 8 9 10
P 1 2 2 3 0 A - D T

Code 1	Code 2	Code 3	Code 4, 5	Code 6, 7	Code 9	Code 10
	Mfg. Year	Mfg. Month	Mfg. Date	Lots	Resin Color	Packaging
Internal Tracing Code	Z: 2000 1: 2001 2: 2002 3: 2003	1: Jan. 2: Feb. 9: Sep. A: Oct. B: Nov. C: Dec.	1~31/ (30)	01~99, A,B,C...	D: Diffused	T: Tape & Reel

Luminous Intensity (Iv) Bin:

Bin	Luminous Intensity Range (mcd)		Bin	Luminous Intensity Range (mcd)	
	Minimum	Maximum		Minimum	Maximum
H1	2.8	3.6	H2	3.6	4.5
J1	4.5	5.7	J2	5.7	7.2
K1	7.2	9.0	K2	9.0	11.2
L1	11.2	14.2	L2	14.2	18.0
M1	18.0	22.5	M2	22.5	28.5
N1	28.5	36.0	N2	36.0	45.0
P1	45.0	57.0	P2	57.0	71.5
Q1	71.5	90.0	Q2	90.0	112.5
R1	112.5	142.0	R2	142.0	180.0
S1	180.0	227.0	S2	227.0	285.0
T1	285.0	360.0	T2	360.0	450.0
U1	450.0	570.0	U2	570.0	715.0

@20mA / Ta=25° C, Tolerance: ± 10%

Official Product	Product: HT-358 Series	Data Sheet No.
Tentative Product	*****	HT-358 Series
Specifications are subject to change without notice. Data and drawings herein are copyrighted.	Mar 30, 2006	Version of 1.2
		Page 7/22

Wavelength (λ_D) Bin:

Bin	Wavelength Range (nm)			
	Red (USD)		Amber (UD)	
	Min	Max	Min	Max
-	615.0	630.0		
A			597.0	600.0
B			600.0	603.0
C			603.0	606.0
D			606.0	609.0
E			609.0	612.0
F			612.0	615.0
H				
J				

Bin	Wavelength Range (nm)			
	True Green (NG)		Blue (NB)	
	Min	Max	Min	Max
-				
A	515.0	520.0	460.0	464.0
B	520.0	525.0	464.0	468.0
C	525.0	530.0	468.0	472.0
D	530.0	535.0	472.0	476.0
E	535.0	540.0	476.0	480.0
F			480.0	485.0
H				
J				

@20mA / Ta=25° C, Tolerance: $\pm 0.5\text{nm}$

Official Product	Product: HT-358 Series		Data Sheet No.
Tentative Product	*****		HT-358 Series
Specifications are subject to change without notice. Data and drawings herein are copyrighted.		Mar 30, 2006	Version of 1.2
			Page 8/22

Forward Voltage (V_F) Bin:

Color	Bin Code	Spec. Range
Blue (NB) Green (NG)	G8	2.7-2.9 V
	H7	2.9-3.1 V
	H8	3.1-3.3 V
	J7	3.3-3.5 V
	J8	3.5-3.7 V
	K7	3.7-3.9 V
Ultra Bright Red (USD) Ultra Bright Amber (UD)	-	2.4 V max

@20mA / Ta=25°C, Tolerance: ± 0.05 V

Official Product	Product: HT-358 Series	Data Sheet No.	
Tentative Product	*****	HT-358 Series	
Specifications are subject to change without notice. Data and drawings herein are copyrighted.	Mar 30, 2006	Version of 1.2	Page 9/22

Product Characteristics

Absolute Maximum Ratings

Product	Emission Color	P _d (mW)	I _F (mA)	I _{FP} * (mA)	V _R (V)	T _{OP} (°C)	T _{ST} (°C)
HT-358 Series	Ultra Bright Amber	72	30	100	5	-30°C~+85°C	-40°C~+90°C
	Ultra Bright Red						
	Blue	78	25	80			
	True Green						

* Condition for I_{FP} is pulse of 1/10 duty and 0.1msec width

Electro-Optical Characteristics

(T_a = 25 °C)

Product	Emission Color	I _F (mA)	V _F (V)		λ(nm)			I _V ** (mcd)	
			typ	max	λ _D	λ _P	Δλ	min	typ
HT-358 Series	Ultra Bright Amber	20	1.9	2.4	605	609	17	90	140
	Ultra Bright Red	20	1.9	2.4	622	636	17	90	140
	Blue	20	3.3	3.9	470	468	40	56	90
	True Green	20	3.3	3.9	527	520	40	90	200

** Per NIST standards

Official Product	Product: HT-358 Series		Data Sheet No.
Tentative Product	*****		HT-358 Series
Specifications are subject to change without notice. Data and drawings herein are copyrighted.		Mar 30, 2006	Version of 1.2
			Page 10/22

Package Outline Dimension

Recommended Soldering Pattern for Reflow Soldering

Unit: mm Tolerance: +/-0.1

Outline Dimension	Solder Pattern
<p>Soldering terminals may shift in the x, y direction.</p>	<p>Unit: mm</p>

Official Product	Product: HT-358 Series		Data Sheet No.
Tentative Product	*****		HT-358 Series
Specifications are subject to change without notice. Data and drawings herein are copyrighted.	Mar 30, 2006	Version of 1.2	Page 11/22

Characteristic Curves for UD (Ultra Bright Amber) and USD (Ultra Bright Red)

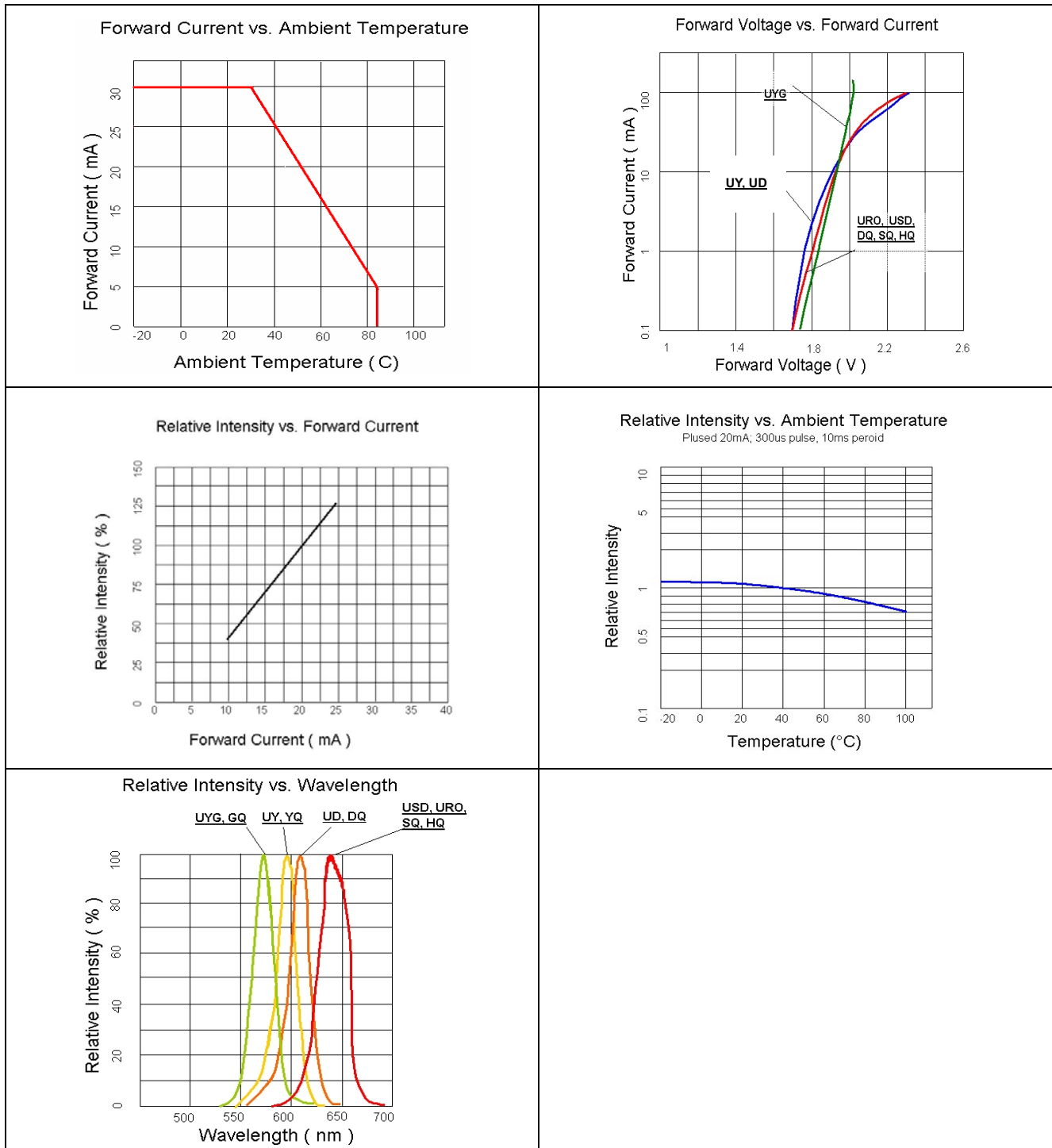

Official Product	Product: HT-358 Series	Data Sheet No.
Tentative Product	*****	HT-358 Series
Specifications are subject to change without notice. Data and drawings herein are copyrighted.	Mar 30, 2006	Version of 1.2
		Page 12/22

Characteristic Curves for NB (Blue) and NG (True Green)

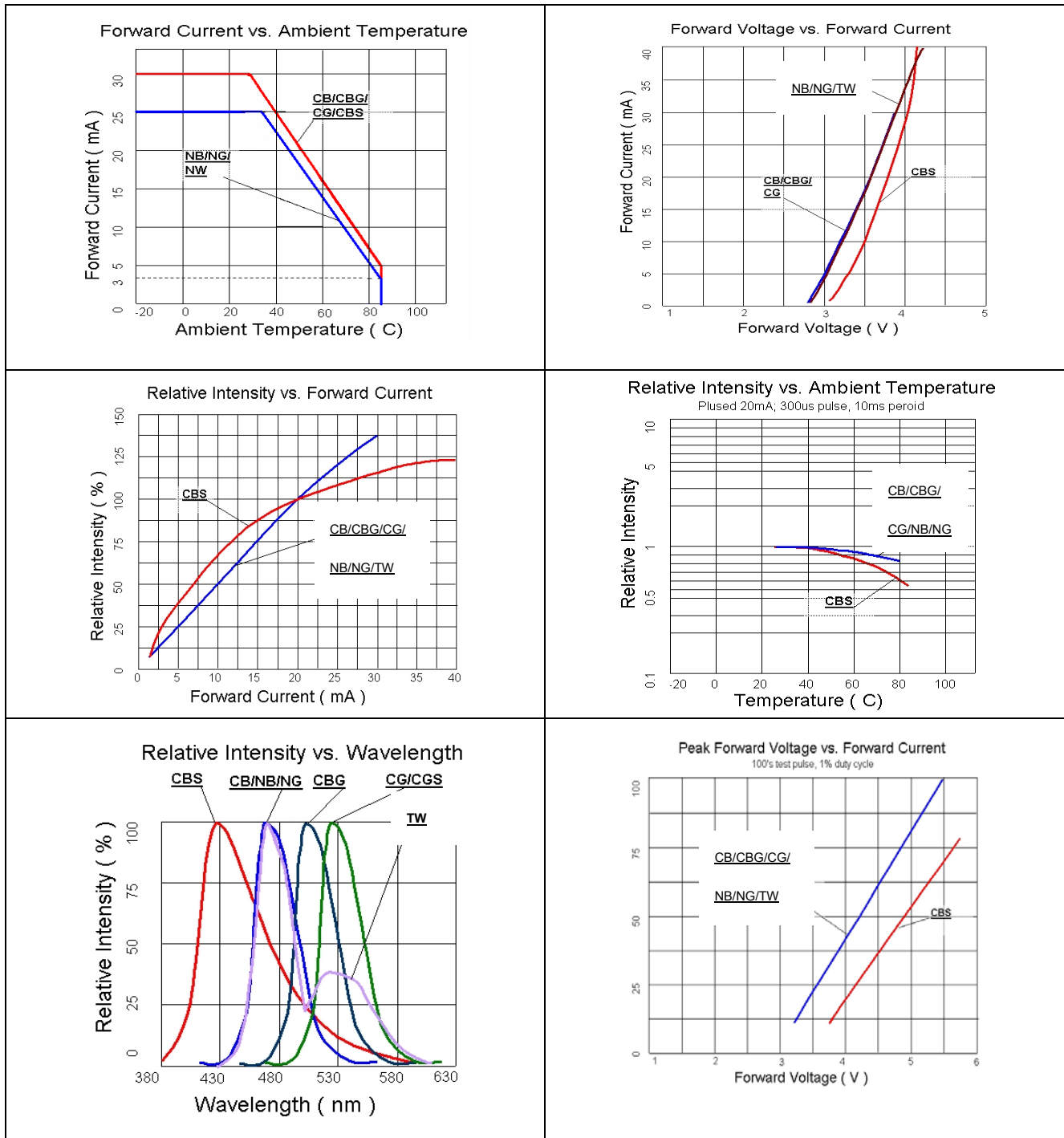

Official Product	Product: HT-358 Series	Data Sheet No.
Tentative Product	*****	HT-358 Series
Specifications are subject to change without notice. Data and drawings herein are copyrighted.	Mar 30, 2006	Version of 1.2
		Page 13/22

Characteristic Curves for All Colors (Radiation Pattern)

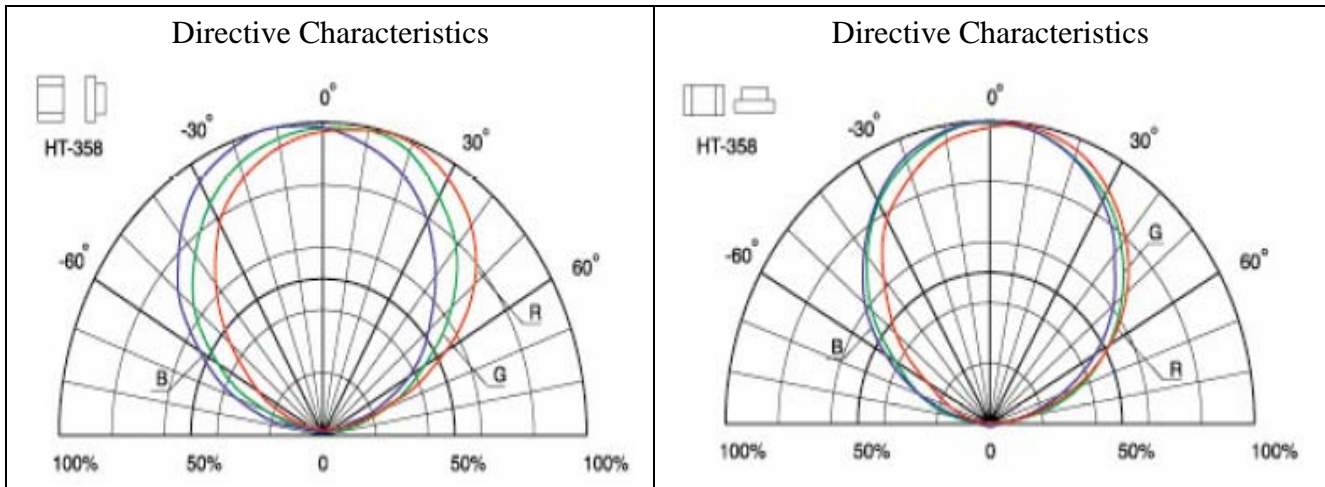

Official Product	Product: HT-358 Series	Data Sheet No.
Tentative Product	*****	HT-358 Series
Specifications are subject to change without notice. Data and drawings herein are copyrighted.	Mar 30, 2006	Version of 1.2
		Page 14/22

Packaging

Tape Dimension

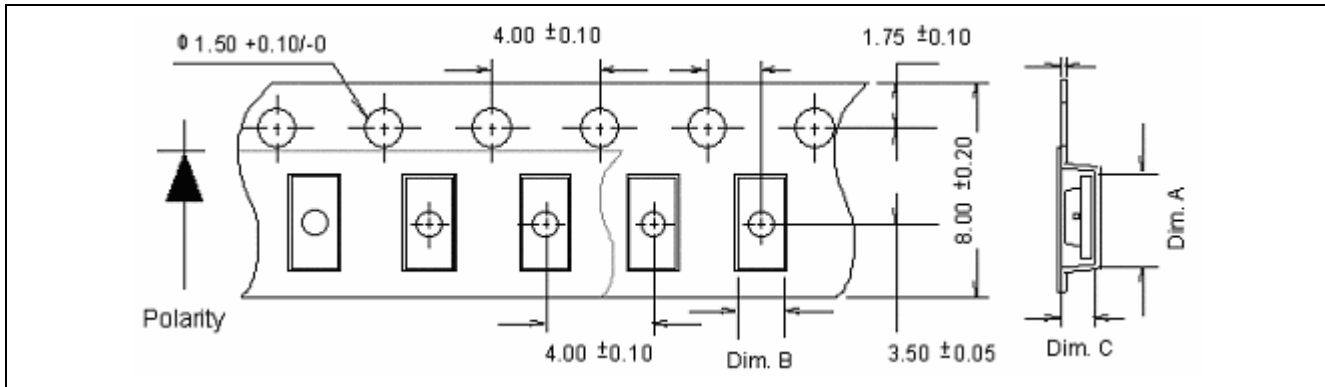

Part No.	Dim. A	Dim. B	Dim. C	Q'ty/Reel
HT-358	3.52±0.10	3.02±0.10	1.40±0.10	3K

Unit: mm

Official Product	Product: HT-358 Series			Data Sheet No.
Tentative Product	*****			HT-358 Series
Specifications are subject to change without notice. Data and drawings herein are copyrighted.		Mar 30, 2006	Version of 1.2	Page 15/22

Reel Dimension

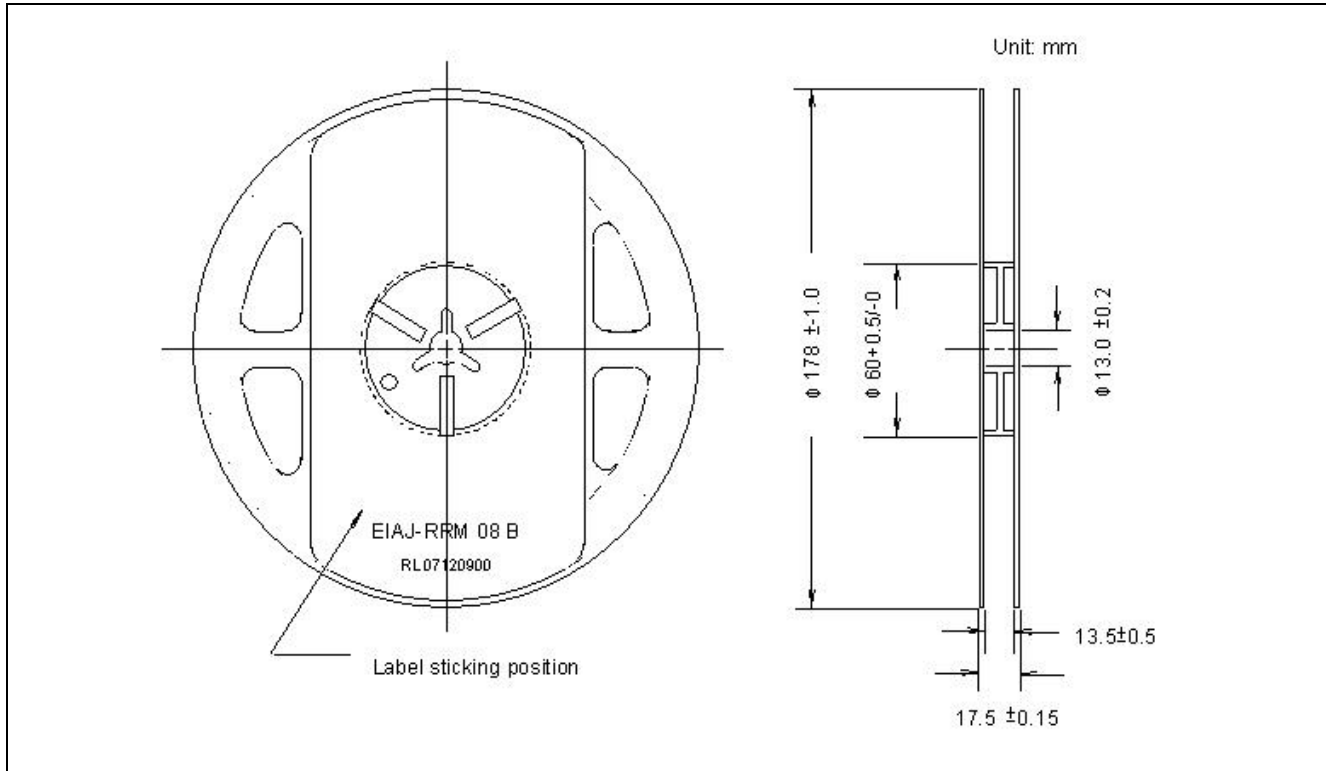

Official Product	Product: HT-358 Series	Data Sheet No.
Tentative Product	*****	HT-358 Series
Specifications are subject to change without notice. Data and drawings herein are copyrighted.	Mar 30, 2006	Version of 1.2
		Page 16/22

Packing

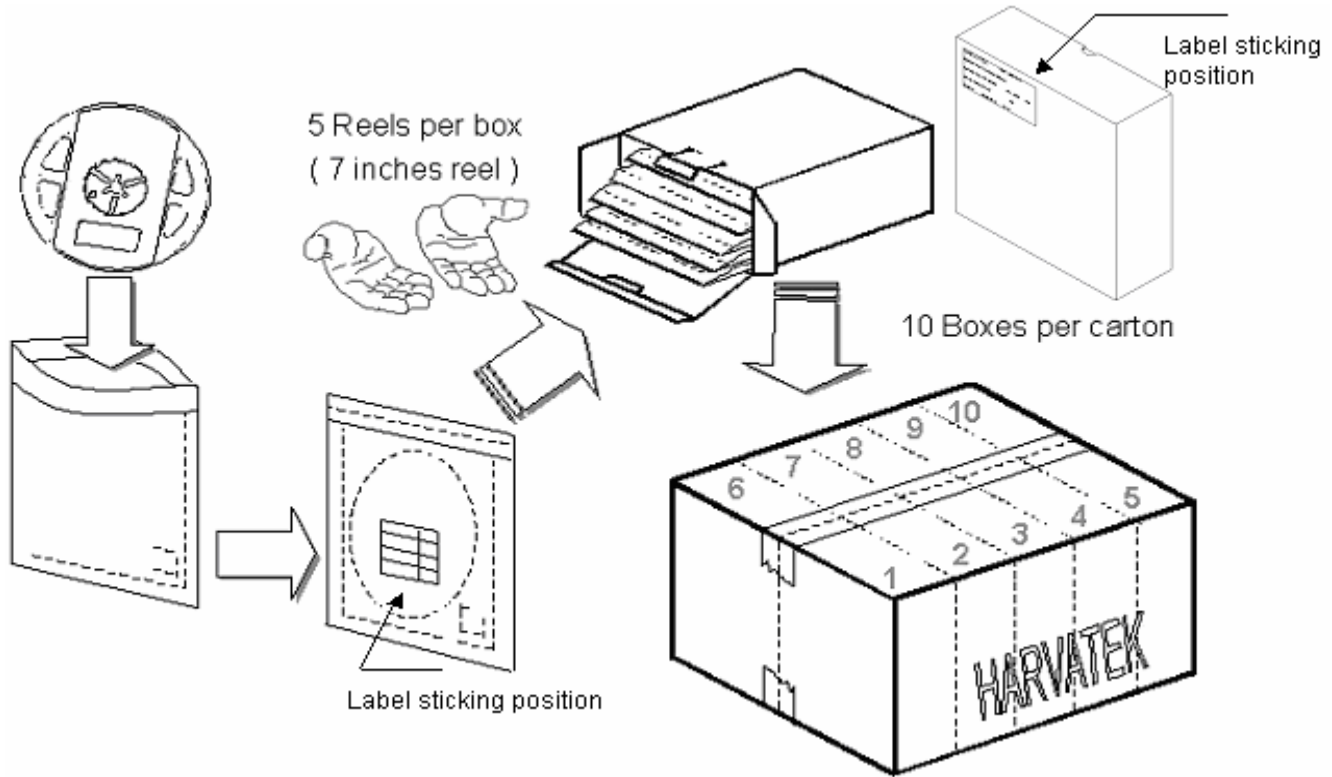

5 boxes per carton is available depending on shipment quantity.

	Specification	Material	Quantity
Carrier tape	Per EIA 481-1A specs	Conductive black tape	3000pcs per reel
Reel	Per EIA 481-1A specs	Conductive black	
Label	HT standard	Paper	
Packing bag	220x240mm	Aluminum laminated bag/ no-zipper	One reel per bag
Carton	HT standard	Paper	Non-specified

Others:

Each immediate box consists of 5 reels. The 5 reels may not necessarily have the same lot number or the same bin combinations of Iv, λD and Vf. Each reel has a label identifying its specification; the immediate box consists of a product label as well.

Official Product	Product: HT-358 Series	Data Sheet No.
Tentative Product	*****	HT-358 Series
Specifications are subject to change without notice. Data and drawings herein are copyrighted.	Mar 30, 2006	Version of 1.2
		Page 17/22

Dry Pack

All SMD optical devices are **MOISTURE SENSITIVE**. Avoid exposure to moisture at all times during transportation or storage. Every reel is packaged in a moisture protected anti-static bag. Each bag is properly sealed prior to shipment.

Upon request, a humidity indicator will be included in the moisture protected anti-static bag prior to shipment.

The packaging sequence is as follows:

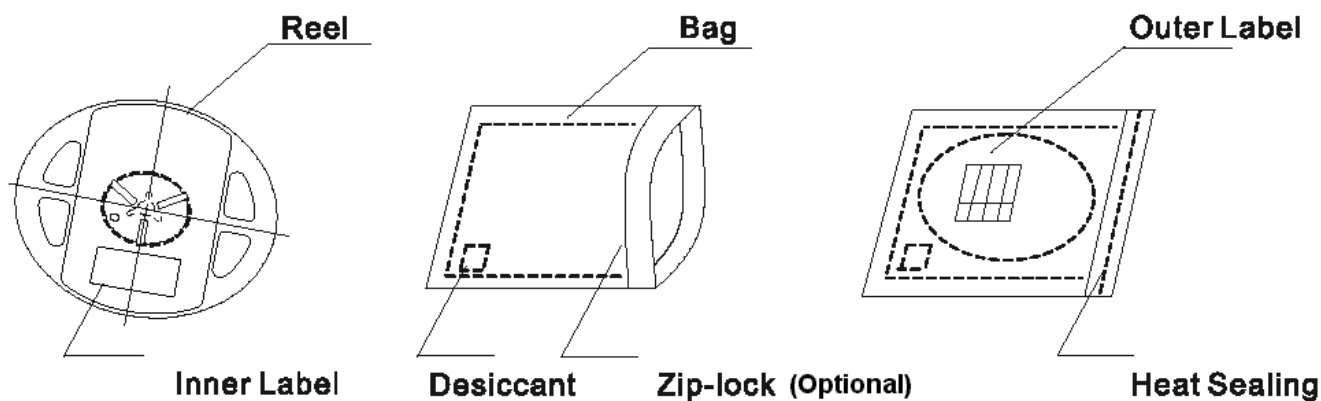

Official Product	Product: HT-358 Series	Data Sheet No.	
Tentative Product	*****	HT-358 Series	
Specifications are subject to change without notice. Data and drawings herein are copyrighted.	Mar 30, 2006	Version of 1.2	Page 18/22

Reflow Soldering

- Recommended tin glue specifications: melting temperature in the range of 178~192 °C
- The recommended reflow soldering profile is as follows (temperatures indicated are as measured on the surface of the LED resin):

Lead Solder Profile

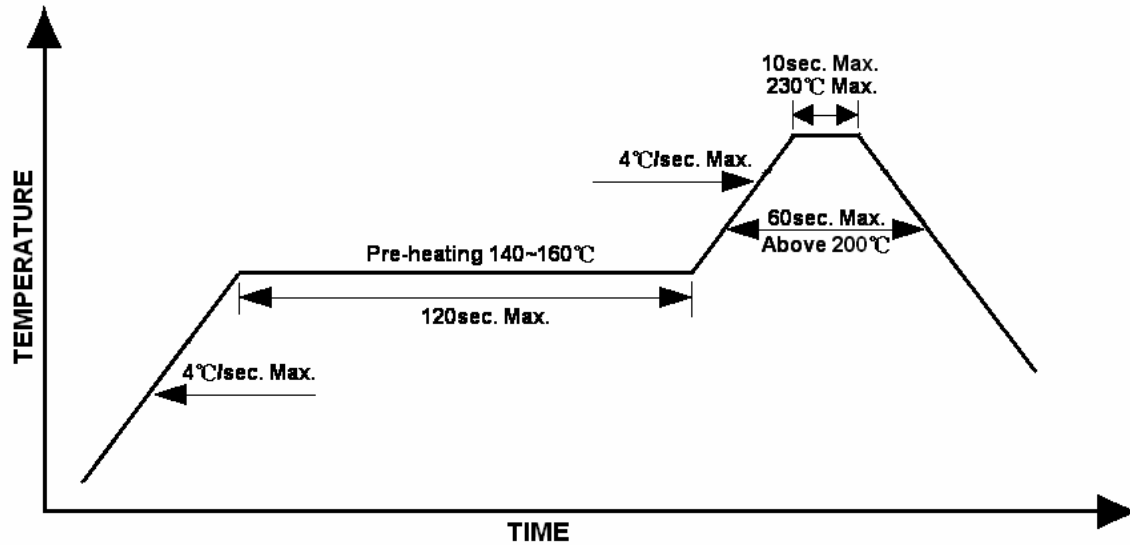

Lead-free Solder Profile

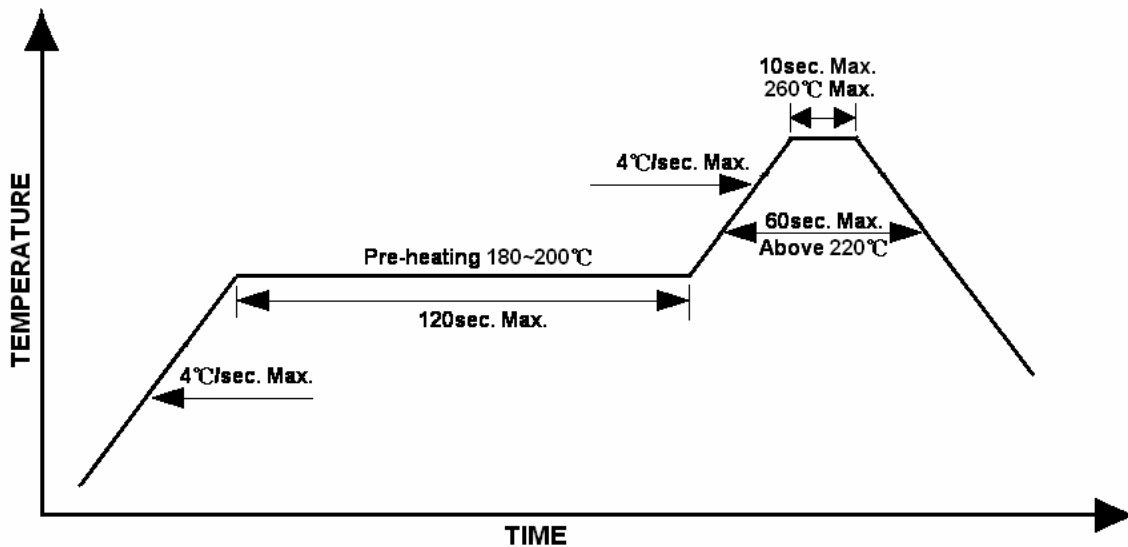

Official Product	Product: HT-358 Series	Data Sheet No.	
Tentative Product	*****	HT-358 Series	
Specifications are subject to change without notice. Data and drawings herein are copyrighted.	Mar 30, 2006	Version of 1.2	Page 19/22

Precautions

1. Avoid exposure to moisture at all times during transportation or storage.
2. Anti-Static precaution must be taken when handling GaN, InGaN, and AlInGaP products.
3. It is suggested to connect the unit with a current limiting resistor of the proper size. Avoid applying a reverse voltage beyond the specified limit.
4. Avoid operation beyond the limits as specified by the absolute maximum ratings.
5. Avoid direct contact with the surface through which the LED emits light.
6. If possible, assemble the unit in a clean room or dust-free environment.

Reworking

- Rework should be completed within 5 seconds under 260 °C.
- The iron tip must not come in contact with the copper foil.
- Twin-head type is preferred.

Cleaning

Following are cleaning procedures after soldering:

- An alcohol-based solvent such as isopropyl alcohol (IPA) is recommended.
- Temperature x Time should be 50°C x 30sec. or <30°C x 3min
- Ultra sonic cleaning: < 15W/ bath; bath volume ≤ 1liter
- Curing: 100 °C max, <3min

Cautions of Pick and Place

- Avoid stress on the resin at elevated temperature.
- Avoid rubbing or scraping the resin by any object.
- Electro-static may cause damage to the component. Please ensure that the equipment is properly grounded. Use of an ionizer fan is recommended.

Official Product	Product: HT-358 Series			Data Sheet No.
Tentative Product	*****			HT-358 Series
Specifications are subject to change without notice. Data and drawings herein are copyrighted.	Mar 30, 2006	Version of 1.2	Page 20/22	

Reliability

Item	Frequency/ lots/ samples/ failures	Standards Reference	Conditions
Precondition	For all reliability monitoring tests according to JEDEC Level 2	J-STD-020	1.) Baking at 85°C for 24hrs 2.) Moisture storage at 85°C/ 60% R.H. for 168hrs
Solderability	1Q/ 1/ 22/ 0	JESD22-B102-B And CNS-5068	Accelerated aging 155°C/ 24hrs Tinning speed: 2.5+0.5cm/s Tinning: A: 215°C/ 3+1s or B: 260°C/ 10+1s
Resistance to soldering heat		CNS-5067	Dipping soldering terminal only Soldering bath temperature A: 260+/-5°C; 10+/-1s B: 350+/-10°C; 3+/-0.5s
Operating life test	1Q/ 1/ 40/ 0	CNS-11829	1.) Precondition: 85°C baking for 24hrs 85°C/ 60%R.H. for 168hrs 2.) Tamb25°C; IF=20mA; duration 1000hrs
High humidity, high temperature bias	1Q/ 1/ 45/ 0	JESD-A101-B	Tamb: 85°C Humidity: 85% R.H., IF=5mA Duration: 1000hrs
High temperature bias	1Q/ 1/ 20	HT specs.	Tamb: 55°C IF=20mA Duration: 1000hrs
Pulse life test	1Q/ 1/ 40/ 0		Tamb25°C, If=20mA,, Ip=100mA, Duty cycle=0.125 (tp=125µs,T=1sec) Duration 500hrs)
Temperature cycle	1Q/ 1/ 76/ 0	JESD-A104-A IEC 68-2-14, Nb	A cycle: -40 degree C 15min; +85 degree C 15min Thermal steady within 5 min.. 300 cycles 2 chamber/ Air-to-air type
High humidity storage test	1Q/ 1/ 40/ 0	CNS-6117	60+3°C 90+5/-10% R.H. for 500hrs
High temperature storage test	1Q/ 1/ 40/ 0	CNS-554	100+10°C for 500hrs
Low temperature storage test	1Q/ 1/ 40/ 0	CNS-6118	-40+5°C for 500hrs

Official Product	Product: HT-358 Series		Data Sheet No.
Tentative Product	*****		HT-358 Series
Specifications are subject to change without notice. Data and drawings herein are copyrighted.	Mar 30, 2006	Version of 1.2	Page 21/22

Revision History

Changes since last revision	Page	Version No.	Revision Date
New format		1.0	06-06-2005
Update characteristic curves	12,13	1.1	10-05-2005
Re-orient recommended solder pattern layout	11	1.2	03-30-2006

Official Product	Product: HT-358 Series		Data Sheet No.
Tentative Product	*****		HT-358 Series
Specifications are subject to change without notice. Data and drawings herein are copyrighted.	Mar 30, 2006	Version of 1.2	Page 22/22