

# 104 dB, 24-Bit, 192 kHz Stereo Audio CODEC

## D/A Features

- ◆ Multi-Bit Delta Sigma Modulator
- ◆ 104 dB Dynamic Range
- ◆ -90 dB THD+N
- ◆ Up to 192 kHz Sampling Rates
- ◆ Single-Ended Analog Architecture
- ◆ Volume Control with Soft Ramp
  - 0.5 dB Step Size
  - Zero Crossing, Click-Free Transitions
- ◆ Popguard® Technology
  - Minimizes the Effects of Output Transients
- ◆ Filtered Line-Level Outputs
- ◆ Selectable Serial Audio Interface Formats
  - Left-Justified up to 24-bit
  - I<sup>2</sup>S up to 24-bit
  - Right-Justified 16-, 18-, 20-, and 24-bit
- ◆ Selectable 50/15 µs De-Emphasis

## A/D Features

- ◆ Multi-Bit Delta Sigma Modulator
- ◆ 104 dB Dynamic Range
- ◆ -95 dB THD+N
- ◆ Stereo 2:1 Input Multiplexer
- ◆ Programmable Gain Amplifier (PGA)
  - ± 12 dB Gain, 0.5 dB Step Size
  - Zero Crossing, Click-Free Transitions
- ◆ Pseudo-Differential Stereo Line Inputs
- ◆ Stereo Microphone Inputs
  - +32 dB Gain Stage
  - Low-Noise Bias Supply
- ◆ Up to 192 kHz Sampling Rates
- ◆ Selectable Serial Audio Interface Formats
  - Left-Justified up to 24-bit
  - I<sup>2</sup>S up to 24-bit
- ◆ High-Pass Filter or DC Offset Calibration

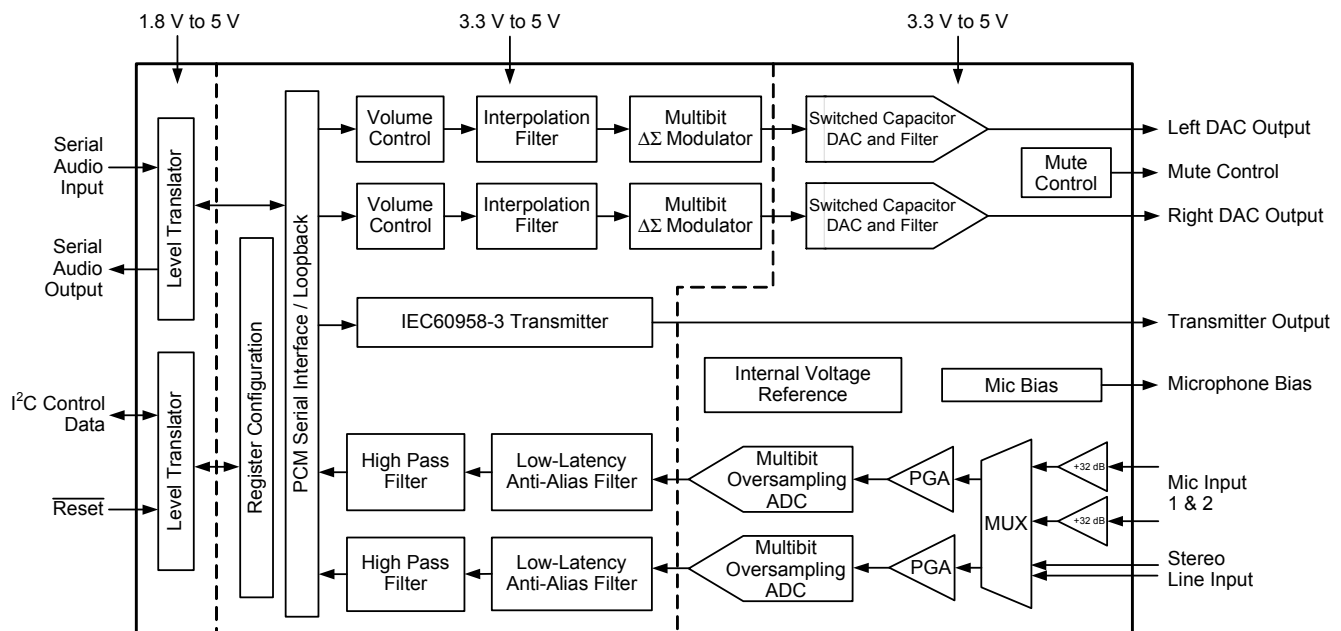

## System Features

- ◆ Synchronous IEC60958-3 Transmitter
  - Up to 192 kHz Sampling Rates
  - 75  $\Omega$  Drive Capability
- ◆ Serial Audio Data Input Multiplexer
- ◆ Internal Digital Loopback
- ◆ Supports Master or Slave Operation
- ◆ Mute Output Control
- ◆ Power-Down Mode
  - Available for A/D, D/A, CODEC, Mic Preamplifier
- ◆ +3.3 V to +5 V Analog Power Supply
- ◆ +3.3 V to +5 V Digital Power Supply
- ◆ Direct Interface with 1.8 V to 5 V Logic Levels
- ◆ Supports I<sup>2</sup>C® Control Port Interface

## General Description

The CS4265 is a highly integrated stereo audio CO-DEC. The CS4265 performs stereo analog-to-digital (A/D) and digital-to-analog (D/A) conversion of up to 24-bit serial values at sample rates up to 192 kHz.

A 2:1 stereo input multiplexer is included for selecting between line-level or microphone-level inputs. The microphone input path includes a +32 dB gain stage and a low noise bias voltage supply. The PGA is available for line or microphone inputs and provides gain or attenuation of  $\pm 12$  dB in 0.5 dB steps.

The output of the PGA is followed by an advanced 5th-order, multi-bit delta sigma modulator and digital filtering/decimation. Sampled data is transmitted by the serial audio interface at rates from 4 kHz to 192 kHz in either Slave or Master Mode.

The D/A converter is based on a 4th-order multi-bit delta sigma modulator with an ultra-linear low-pass filter and offers a volume control that operates with a 0.5 dB step size. It incorporates selectable soft ramp and zero crossing transition functions to eliminate clicks and pops.

Standard 50/15  $\mu$ s de-emphasis is available for a 44.1 kHz sample rate for compatibility with digital audio programs mastered using the 50/15  $\mu$ s pre-emphasis technique.

Integrated level translators allow easy interfacing between the CS4265 and other devices operating over a wide range of logic levels.

The CS4265 is available in a 32-pin QFN package for both Commercial ( $-10^{\circ}$  to  $+70^{\circ}$  C) and Automotive ( $-40^{\circ}$  to  $+105^{\circ}$  C) grade. The CDB4265 is also available for device evaluation and implementation suggestions. Please refer to [“Ordering Information” on page 56](#) for complete details.

---

**TABLE OF CONTENTS**

<b>1. PIN DESCRIPTIONS</b> .....	<b>7</b>
<b>2. CHARACTERISTICS AND SPECIFICATIONS</b> .....	<b>9</b>
SPECIFIED OPERATING CONDITIONS .....	9
ABSOLUTE MAXIMUM RATINGS .....	9
DAC ANALOG CHARACTERISTICS .....	10
DAC COMBINED INTERPOLATION & ON-CHIP ANALOG FILTER RESPONSE .....	11
ADC ANALOG CHARACTERISTICS .....	13
ADC ANALOG CHARACTERISTICS .....	15
ADC DIGITAL FILTER CHARACTERISTICS .....	16
DC ELECTRICAL CHARACTERISTICS .....	17
DIGITAL INTERFACE CHARACTERISTICS .....	18
SWITCHING CHARACTERISTICS - SERIAL AUDIO PORT .....	19
SWITCHING CHARACTERISTICS - I <sup>2</sup> C CONTROL PORT .....	22
<b>3. TYPICAL CONNECTION DIAGRAM</b> .....	<b>23</b>
<b>4. APPLICATIONS</b> .....	<b>24</b>
4.1 Recommended Power-Up Sequence .....	24
4.2 System Clocking .....	24
4.2.1 Master Clock .....	24
4.2.2 Master Mode .....	25
4.2.3 Slave Mode .....	25
4.3 High-Pass Filter and DC Offset Calibration .....	25
4.4 Analog Input Multiplexer, PGA, and Mic Gain .....	26
4.5 Input Connections .....	26
4.5.1 Pseudo-Differential Input .....	26
4.6 Output Connections .....	27
4.7 Output Transient Control .....	27
4.7.1 Power-Up .....	27
4.7.2 Power-Down .....	27
4.7.3 Serial Interface Clock Changes .....	27
4.8 DAC Serial Data Input Multiplexer .....	28
4.9 De-Emphasis Filter .....	28
4.10 Internal Digital Loopback .....	28
4.11 Mute Control .....	29
4.12 AES3 Transmitter .....	29
4.12.1 TxOut Driver .....	29
4.12.2 Mono Mode Operation .....	30
4.13 I <sup>2</sup> C Control Port Description and Timing .....	30
4.14 Status Reporting .....	31
4.15 Reset .....	32
4.16 Synchronization of Multiple Devices .....	32
4.17 Grounding and Power Supply Decoupling .....	32
4.18 Package Considerations .....	32
<b>5. REGISTER QUICK REFERENCE</b> .....	<b>33</b>
<b>6. REGISTER DESCRIPTION</b> .....	<b>35</b>
6.1 Chip ID - Register 01h .....	35
6.2 Power Control - Address 02h .....	35
6.2.1 Freeze (Bit 7) .....	35
6.2.2 Power-Down MIC (Bit 3) .....	35
6.2.3 Power-Down ADC (Bit 2) .....	35
6.2.4 Power-Down DAC (Bit 1) .....	36
6.2.5 Power-Down Device (Bit 0) .....	36
6.3 DAC Control - Address 03h .....	36

6.3.1 DAC Digital Interface Format (Bits 5:4) .....	36
6.3.2 Mute DAC (Bit 2) .....	36
6.3.3 De-Emphasis Control (Bit 1) .....	37
6.4 ADC Control - Address 04h .....	37
6.4.1 Functional Mode (Bits 7:6) .....	37
6.4.2 ADC Digital Interface Format (Bit 4) .....	37
6.4.3 Mute ADC (Bit 2) .....	38
6.4.4 ADC High-Pass Filter Freeze (Bit 1) .....	38
6.4.5 Master / Slave Mode (Bit 0) .....	38
6.5 MCLK Frequency - Address 05h .....	38
6.5.1 Master Clock Dividers (Bits 6:4) .....	38
6.6 Signal Selection - Address 06h .....	39
6.6.1 DAC SDIN Source (Bit 7) .....	39
6.6.2 Digital Loopback (Bit 1) .....	39
6.7 Channel B PGA Control - Address 07h .....	39
6.7.1 Channel B PGA Gain (Bits 5:0) .....	39
6.8 Channel A PGA Control - Address 08h .....	39
6.8.1 Channel A PGA Gain (Bits 5:0) .....	39
6.9 ADC Input Control - Address 09h .....	40
6.9.1 PGA Soft Ramp or Zero Cross Enable (Bits 4:3) .....	40
6.9.2 Analog Input Selection (Bit 0) .....	40
6.10 DAC Channel A Volume Control - Address 0Ah .....	40
6.11 DAC Channel B Volume Control - Address 0Bh .....	41
6.11.1 Volume Control (Bits 7:0) .....	41
6.12 DAC Control 2 - Address 0Ch .....	41
6.12.1 DAC Soft Ramp or Zero Cross Enable (Bits 7:6) .....	41
6.12.2 Invert DAC Output (Bit 5) .....	42
6.13 Status - Address 0Dh .....	42
6.13.1 E to F C-Buffer Transfer .....	42
6.13.2 Clock Error (Bit 3) .....	42
6.13.3 ADC Overflow (Bit 1) .....	42
6.13.4 ADC Underflow (Bit 0) .....	42
6.14 Status Mask - Address 0Eh .....	43
6.15 Status Mode MSB - Address 0Fh .....	43
6.16 Status Mode LSB - Address 10h .....	43
6.17 Transmitter Control 1 - Address 11h .....	43
6.17.1 E to F C-Data Buffer Transfer Inhibit (Bit 6) .....	43
6.17.2 C-Data Access Mode (Bit 5) .....	43
6.18 Transmitter Control 2 - Address 12h .....	44
6.18.1 Transmitter Digital Interface Format (Bits 7:6) .....	44
6.18.2 Transmitter Output Driver Control (Bit 5) .....	44
6.18.3 Transmitter Mute Control (Bit 4) .....	44
6.18.4 Transmitted Validity Bit Control (Bit 3) .....	44
6.18.5 Transmitter Mono/Stereo Operation Control (Bit 2) .....	44
6.18.6 Mono Mode CS Data Source (Bit 1) .....	44
6.18.7 Mono Mode Channel Selection (Bit 0) .....	45
<b>7. PARAMETER DEFINITIONS .....</b>	<b>46</b>
<b>8. DAC FILTER PLOTS .....</b>	<b>47</b>
<b>9. ADC FILTER PLOTS .....</b>	<b>49</b>
<b>10. EXTERNAL IEC60958-3 TRANSMITTER COMPONENTS .....</b>	<b>51</b>
10.1 IEC60958-3 Transmitter External Components .....	51
10.2 Isolating Transformer Requirements .....	51
<b>11. CHANNEL STATUS BUFFER MANAGEMENT .....</b>	<b>52</b>
11.1 IEC60958-3 Channel Status (C) Bit Management .....	52

11.1.1 Accessing the E Buffer .....	53
11.2 Serial Copy Management System (SCMS) .....	53
11.3 Channel Status Data E Buffer Access .....	53
11.3.1 One-Byte Mode .....	54
11.3.2 Two-Byte Mode .....	54
<b>12. PACKAGE DIMENSIONS .....</b>	<b>55</b>
<b>13. THERMAL CHARACTERISTICS AND SPECIFICATIONS .....</b>	<b>55</b>
<b>14. ORDERING INFORMATION .....</b>	<b>56</b>
<b>15. REVISION HISTORY .....</b>	<b>56</b>

## LIST OF FIGURES

Figure 1.DAC Output Test Load .....	12
Figure 2.Maximum DAC Loading .....	12
Figure 3.Master Mode Serial Audio Port Timing .....	20
Figure 4.Slave Mode Serial Audio Port Timing .....	20
Figure 5.Format 0, Left-Justified up to 24-Bit Data .....	21
Figure 6.Format 1, I <sup>2</sup> S up to 24-Bit Data .....	21
Figure 7.Format 2, Right-Justified 16-Bit Data. Format 3, Right-Justified 24-Bit Data. ....	21
Figure 8.Control Port Timing - I <sup>2</sup> C Format .....	22
Figure 9.Typical Connection Diagram .....	23
Figure 10.Master Mode Clocking .....	25
Figure 11.Analog Input Architecture .....	26
Figure 12.Pseudo-Differential Input Stage .....	27
Figure 13.De-Emphasis Curve .....	28
Figure 14.Suggested Active-Low Mute Circuit .....	29
Figure 15.Control Port Timing, I <sup>2</sup> C Write .....	31
Figure 16.Control Port Timing, I <sup>2</sup> C Read .....	31
Figure 17.De-Emphasis Curve .....	37
Figure 18.DAC Single-Speed Stopband Rejection .....	47
Figure 19.DAC Single-Speed Transition Band .....	47
Figure 20.DAC Single-Speed Transition Band .....	47
Figure 21.DAC Single-Speed Passband Ripple .....	47
Figure 22.DAC Double-Speed Stopband Rejection .....	47
Figure 23.DAC Double-Speed Transition Band .....	47
Figure 24.DAC Double-Speed Transition Band .....	48
Figure 25.DAC Double-Speed Passband Ripple .....	48
Figure 26.DAC Quad-Speed Stopband Rejection .....	48
Figure 27.DAC Quad-Speed Transition Band .....	48
Figure 28.DAC Quad-Speed Transition Band .....	48
Figure 29.DAC Quad-Speed Passband Ripple .....	48
Figure 30.ADC Single-Speed Stopband Rejection .....	49
Figure 31.ADC Single-Speed Stopband Rejection .....	49
Figure 32.ADC Single-Speed Transition Band (Detail) .....	49
Figure 33.ADC Single-Speed Passband Ripple .....	49
Figure 34.ADC Double-Speed Stopband Rejection .....	49
Figure 35.ADC Double-Speed Stopband Rejection .....	49
Figure 36.ADC Double-Speed Transition Band (Detail) .....	50
Figure 37.ADC Double-Speed Passband Ripple .....	50
Figure 38.ADC Quad-Speed Stopband Rejection .....	50
Figure 39.ADC Quad-Speed Stopband Rejection .....	50
Figure 40.ADC Quad-Speed Transition Band (Detail) .....	50
Figure 41.ADC Quad-Speed Passband Ripple .....	50

Figure 42. Consumer Output Circuit (VD = 5 V) .....	51
Figure 43. TTL/CMOS Output Circuit .....	51
Figure 44. Channel Status Data Buffer Structure .....	52
Figure 45. Flowchart for Writing the E Buffer .....	53

## LIST OF TABLES

Table 1. Speed Modes .....	24
Table 2. Common Clock Frequencies .....	24
Table 3. Slave Mode Serial Bit Clock Ratios .....	25
Table 4. Device Revision .....	35
Table 5. Freeze-able Bits .....	35
Table 6. DAC Digital Interface Formats .....	36
Table 7. De-Emphasis Control .....	37
Table 8. Functional Mode Selection .....	37
Table 9. ADC Digital Interface Formats .....	38
Table 10. MCLK Frequency .....	38
Table 11. DAC SDIN Source Selection .....	39
Table 12. Example Gain and Attenuation Settings .....	39
Table 13. PGA Soft Cross or Zero Cross Mode Selection .....	40
Table 14. Analog Input Selection .....	40
Table 15. Digital Volume Control Example Settings .....	41
Table 16. DAC Soft Cross or Zero Cross Mode Selection .....	42
Table 17. Transmitter Digital Interface Formats .....	44

## 1. PIN DESCRIPTIONS

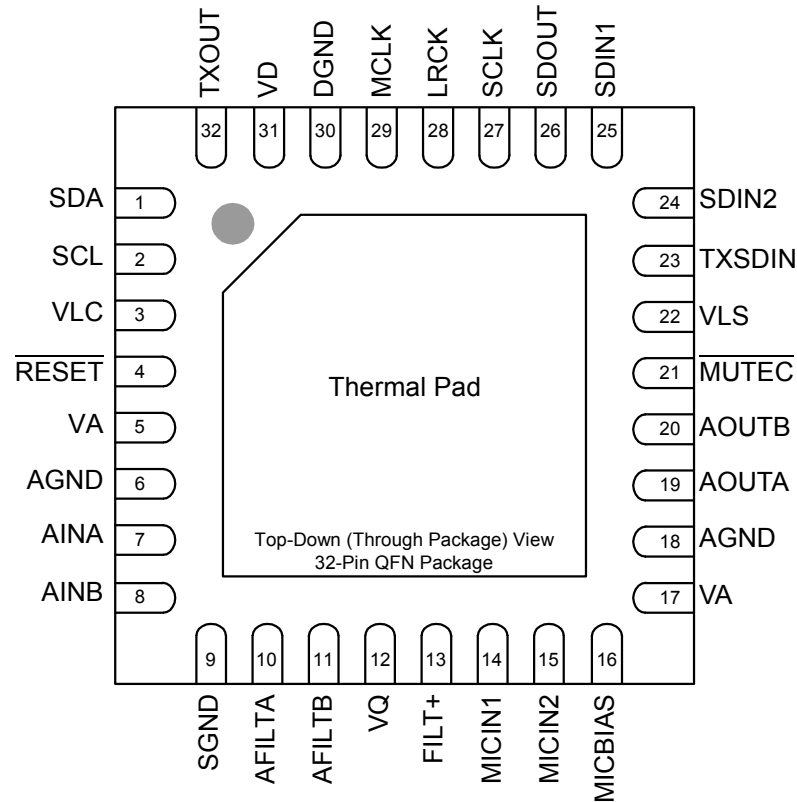

Pin Name	#	Pin Description
SDA	1	<b>Serial Control Data (Input/Output)</b> - Bidirectional data line for the I <sup>2</sup> C control port.
SCL	2	<b>Serial Control Port Clock (Input)</b> - Serial clock for the I <sup>2</sup> C control port.
VLC	3	<b>Control Port Power (Input)</b> - Determines the required signal level for the control port interface. Refer to the Recommended Operating Conditions for appropriate voltages.
$\overline{\text{RESET}}$	4	<b>Reset (Input)</b> - The device enters a low-power mode when this pin is driven low.
VA	5	<b>Analog Power (Input)</b> - Positive power for the internal analog section.
AGND	6	<b>Analog Ground (Input)</b> - Ground reference for the internal analog section.
AINA AINB	7, 8	<b>Analog Input (Input)</b> - The full-scale level is specified in the ADC Analog Characteristics specification table.
SGND	9	<b>Signal Ground (Input)</b> - Ground reference for the analog line inputs.
AFILTA AFILTB	10, 11	<b>Antialias Filter Connection (Output)</b> - Antialias filter connection for the ADC inputs.
VQ	12	<b>Quiescent Voltage (Output)</b> - Filter connection for internal quiescent voltage.
FILT+	13	<b>Positive Voltage Reference (Output)</b> - Positive reference voltage for the internal sampling circuits.
MICIN1 MICIN2	14, 15	<b>Microphone Input (Input)</b> - The full-scale level is specified in the ADC Analog Characteristics specification table.
MICBIAS	16	<b>Microphone Bias (Output)</b> - Low noise bias supply for external microphone. Electrical characteristics are specified in the DC Electrical Characteristics table.

VA	17	<b>Analog Power (Input)</b> - Positive power for the internal analog section.
AGND	18	<b>Analog Ground (Input)</b> - Ground reference for the internal analog section.
AOUTA AOUTB	19, 20	<b>Analog Audio Output (Output)</b> - The full scale output level is specified in the DAC Analog Characteristics specification table.
$\overline{\text{MUTE C}}$	21	<b>Mute Control (Output)</b> - This pin is active during power-up initialization, reset, muting, when master clock left/right clock frequency ratio is incorrect, or power-down.
VLS	22	<b>Serial Audio Interface Power (Input)</b> - Determines the required signal level for the serial audio interface. Refer to the Recommended Operating Conditions for appropriate voltages.
TXSDIN	23	<b>Transmitter Serial Audio Data Input (Input)</b> - Input for two's complement serial audio data.
SDIN2	24	<b>Serial Audio Data Input 2 (Input)</b> - Input for two's complement serial audio data.
SDIN1	25	<b>Serial Audio Data Input 1 (Input)</b> - Input for two's complement serial audio data.
SDOUT	26	<b>Serial Audio Data Output (Output)</b> - Output for two's complement serial audio data.
SCLK	27	<b>Serial Clock (Input/Output)</b> - Serial clock for the serial audio interface.
LRCK	28	<b>Left Right Clock (Input/Output)</b> - Determines which channel, Left or Right, is currently active on the serial audio data line.
MCLK	29	<b>Master Clock (Input)</b> - Clock source for the delta-sigma modulators.
DGND	30	<b>Digital Ground (Input)</b> - Ground reference for the internal digital section.
VD	31	<b>Digital Power (Input)</b> - Positive power for the internal digital section.
TXOUT	32	<b>Transmitter Line Driver Output (Output)</b> - IEC60958-3 driver output.
Thermal Pad	-	<b>Thermal Pad</b> - Thermal relief pad for optimized heat dissipation.



## 2. CHARACTERISTICS AND SPECIFICATIONS

### SPECIFIED OPERATING CONDITIONS

AGND = DGND = 0 V; All voltages with respect to ground.

Parameters		Symbol	Min	Nom	Max	Units
DC Power Supplies:	Analog	VA	3.13	5.0	5.25	V
	Digital	VD	3.13	3.3	(Note 1)	V
	Logic - Serial Port	VLS	1.71	3.3	5.25	V
	Logic - Control Port	VLC	1.71	3.3	5.25	V
Ambient Operating Temperature (Power Applied)	Commercial	T <sub>A</sub>	-10	-	+70	°C
	Automotive	T <sub>A</sub>	-40	-	+105	°C

**Notes:** 1. Maximum of VA+0.25 V or 5.25 V, whichever is less.

### ABSOLUTE MAXIMUM RATINGS

AGND = DGND = 0 V All voltages with respect to ground. (Note 2)

Parameter		Symbol	Min	Max	Units
DC Power Supplies:	Analog	VA	-0.3	+6.0	V
	Digital	VD	-0.3	+6.0	V
	Logic - Serial Port	VLS	-0.3	+6.0	V
	Logic - Control Port	VLC	-0.3	+6.0	V
Input Current	(Note 3)	I <sub>in</sub>	-	±10	mA
Analog Input Voltage		V <sub>INA</sub>	AGND-0.3	VA+0.3	V
Digital Input Voltage	Logic - Serial Port	V <sub>IND-S</sub>	-0.3	VLS+0.3	V
	Logic - Control Port	V <sub>IND-C</sub>	-0.3	VLC+0.3	V
Ambient Operating Temperature (Power Applied)		T <sub>A</sub>	-50	+125	°C
Storage Temperature		T <sub>stg</sub>	-65	+150	°C

2. Operation beyond these limits may result in permanent damage to the device. Normal operation is not guaranteed at these extremes.
3. Any pin except supplies. Transient currents of up to ±100 mA on the analog input pins will not cause SCR latch-up.

## DAC ANALOG CHARACTERISTICS

Test Conditions (unless otherwise specified): AGND = DGND = 0 V; VA = 3.13 V to 5.25 V; VD = 3.13 V to 5.25 V or VA + 0.25 V, whichever is less; VLS = VLC = 1.71 V to 5.25 V; T<sub>A</sub> = -10° to +70° C for Commercial or -40° to +85° C for Automotive; Output test signal: 997 Hz full-scale sine wave; Test load R<sub>L</sub> = 3 kΩ, C<sub>L</sub> = 10 pF (see Figure 1), F<sub>s</sub> = 48/96/192 kHz. Measurement Bandwidth 10 Hz to 20 kHz; All Connections as shown in Figure 9 on page 23.

Parameter	Symbol	Commercial Grade			Automotive Grade			Unit	
		Min	Typ	Max	Min	Typ	Max		
<b>Dynamic Performance for VA = 4.75 V to 5.25 V</b>									
Dynamic Range	(Note 4)								
18 to 24-Bit	A-Weighted	98	104	-	96	104	-	dB	
	unweighted	95	101	-	93	101	-	dB	
16-Bit	A-Weighted	90	96	-	88	96	-	dB	
	unweighted	87	93	-	85	93	-	dB	
Total Harmonic Distortion + Noise	(Note 4)								
18 to 24-Bit	0 dB	-	-90	-84	-	-90	-82	dB	
	-20 dB	-	-81	-	-	-81	-	dB	
	-60 dB	-	-41	-	-	-41	-	dB	
16-Bit	0 dB	-	-93	-87	-	-93	-85	dB	
	-20 dB	-	-73	-	-	-73	-	dB	
	-60 dB	-	-33	-	-	-33	-	dB	
<b>Dynamic Performance for VA = 3.13 V to 3.46 V</b>									
Dynamic Range	(Note 4)								
18 to 24-Bit	A-Weighted	95	101	-	93	101	-	dB	
	unweighted	92	98	-	90	98	-	dB	
16-Bit	A-Weighted	88	93	-	86	93	-	dB	
	unweighted	85	90	-	83	90	-	dB	
Total Harmonic Distortion + Noise	(Note 4)								
18 to 24-Bit	0 dB	-	-87	-79	-	-87	-77	dB	
	-20 dB	-	-78	-	-	-78	-	dB	
	-60 dB	-	-38	-	-	-38	-	dB	
16-Bit	0 dB	-	-90	-82	-	-90	-80	dB	
	-20 dB	-	-70	-	-	-70	-	dB	
	-60 dB	-	-30	-	-	-30	-	dB	
Interchannel Isolation	(1 kHz)	-	100	-	-	100	-	dB	
<b>DC Accuracy</b>									
Interchannel Gain Mismatch		-	0.1	0.25	-	0.1	0.25	dB	
Gain Drift		-	100	-	-	100	-	ppm/°C	
<b>Analog Output</b>									
Full Scale Output Voltage		0.60*VA	0.65*VA	0.70*VA	0.60*VA	0.65*VA	0.70*VA	V <sub>pp</sub>	
DC Current draw from an AOUT pin	(Note 5)	I <sub>OUT</sub>	-	-	10	-	-	10	μA
AC-Load Resistance	(Note 6)	R <sub>L</sub>	3	-	-	3	-	-	kΩ
Load Capacitance	(Note 6)	C <sub>L</sub>	-	-	100	-	-	100	pF
Output Impedance		Z <sub>OUT</sub>	-	150	-	-	150	-	Ω

- One-half LSB of triangular PDF dither added to data.
- Guaranteed by design. The DC current draw represents the allowed current draw from the AOUT pin due to typical leakage through the electrolytic DC blocking capacitors.

6. Guaranteed by design. See Figure 2.  $R_L$  and  $C_L$  reflect the recommended minimum resistance and maximum capacitance required for the internal op-amp's stability.  $C_L$  affects the dominant pole of the internal output amp; increasing  $C_L$  beyond 100 pF can cause the internal op-amp to become unstable.

## DAC COMBINED INTERPOLATION & ON-CHIP ANALOG FILTER RESPONSE

Parameter (Note 7,10)	Symbol	Min	Typ	Max	Unit
<b>Combined Digital and On-chip Analog Filter Response</b>		<b>Single-Speed Mode</b>			
Passband (Note 7)	to -0.1 dB corner to -3 dB corner	0	-	0.35	Fs
		0	-	0.4992	Fs
Frequency Response 10 Hz to 20 kHz		-0.175	-	+0.01	dB
StopBand		0.5465	-	-	Fs
StopBand Attenuation	(Note 8)	50	-	-	dB
Group Delay	tgd	-	10/Fs	-	s
De-emphasis Error (Note 9)	Fs = 44.1 kHz	-	-	+0.05/-0.25	dB
<b>Combined Digital and On-chip Analog Filter Response</b>		<b>Double-Speed Mode</b>			
Passband (Note 7)	to -0.1 dB corner to -3 dB corner	0	-	0.22	Fs
		0	-	0.501	Fs
Frequency Response 10 Hz to 20 kHz		-0.15	-	+0.15	dB
StopBand		0.5770	-	-	Fs
StopBand Attenuation	(Note 8)	55	-	-	dB
Group Delay	tgd	-	5/Fs	-	s
<b>Combined Digital and On-chip Analog Filter Response</b>		<b>Quad-Speed Mode</b>			
Passband (Note 7)	to -0.1 dB corner to -3 dB corner	0	-	0.110	Fs
		0	-	0.469	Fs
Frequency Response 10 Hz to 20 kHz		-0.12	-	0	dB
StopBand		0.7	-	-	Fs
StopBand Attenuation	(Note 8)	51	-	-	dB
Group Delay	tgd	-	2.5/Fs	-	s

7. Filter response is guaranteed by design.
8. For Single-Speed Mode, the Measurement Bandwidth is 0.5465 Fs to 3 Fs.  
For Double-Speed Mode, the Measurement Bandwidth is 0.577 Fs to 1.4 Fs.  
For Quad-Speed Mode, the Measurement Bandwidth is 0.7 Fs to 1 Fs.
9. De-emphasis is available only in Single-Speed Mode.
10. Response is clock dependent and will scale with Fs. Note that the amplitude vs. frequency plots of this data (Figures 18 to 27) have been normalized to Fs and can be de-normalized by multiplying the X-axis scale by Fs.

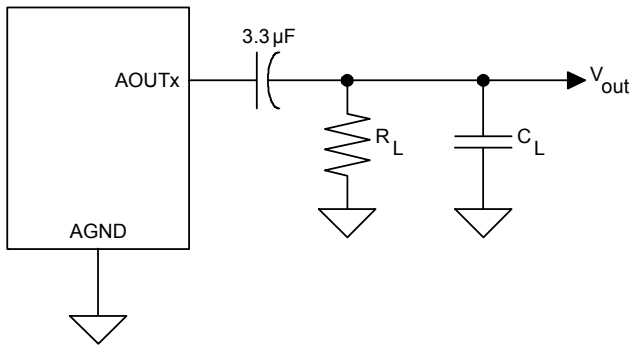

**Figure 1. DAC Output Test Load**

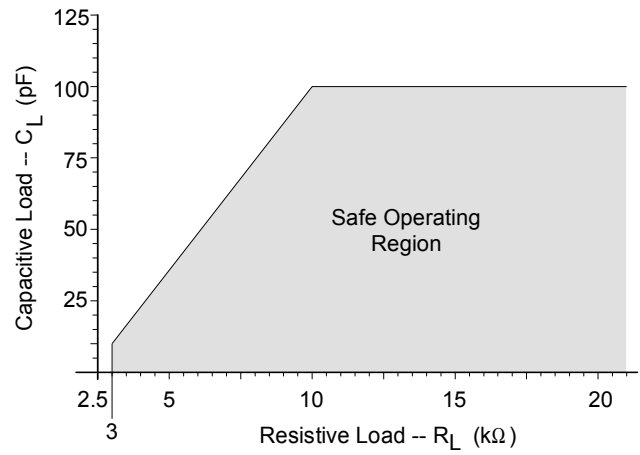

**Figure 2. Maximum DAC Loading**

## ADC ANALOG CHARACTERISTICS

Test conditions (unless otherwise specified): AGND = DGND = 0 V; VA = 3.13 V to 5.25 V; VD = 3.13 V to 5.25 V or VA + 0.25 V, whichever is less; VLS = VLC = 1.71 V to 5.25 V; T<sub>A</sub> = -10° to +70° C for Commercial or -40° to +85° C for Automotive; Input test signal: 1 kHz sine wave; measurement bandwidth is 10 Hz to 20 kHz; F<sub>s</sub> = 48/96/192 kHz.; All connections as shown in [Figure 9 on page 23](#).

Line-Level Inputs								
Parameter	Symbol	Commercial Grade			Automotive Grade			Unit
		Min	Typ	Max	Min	Typ	Max	
<b>Dynamic Performance for VA = 4.75 V to 5.25 V</b>								
Dynamic Range								
	PGA Setting: -12 dB to +6 dB							
	A-weighted	98	104	-	96	104	-	dB
	unweighted	95	101	-	93	101	-	dB
(Note 13)	40 kHz bandwidth unweighted	-	98	-	-	98	-	dB
	PGA Setting: +12 dB Gain							
	A-weighted	92	98	-	90	98	-	dB
	unweighted	89	95	-	87	95	-	dB
(Note 13)	40 kHz bandwidth unweighted	-	92	-	-	92	-	dB
Total Harmonic Distortion + Noise	(Note 12)							
	PGA Setting: -12 dB to +6 dB							
	-1 dB	-	-95	-89	-	-95	-87	dB
	-20 dB	-	-81	-	-	-81	-	dB
	-60 dB	-	-41	-	-	-41	-	dB
(Note 13)	40 kHz bandwidth -1 dB	-	-92	-	-	-92	-	dB
	PGA Setting: +12 dB Gain							
	-1 dB	-	-92	-86	-	-92	-84	dB
	-20 dB	-	-75	-	-	-75	-	dB
	-60 dB	-	-35	-	-	-35	-	dB
(Note 13)	40 kHz bandwidth -1 dB	-	-89	-	-	-89	-	dB
<b>Dynamic Performance for VA = 3.13 V to 3.46 V</b>								
Dynamic Range								
	PGA Setting: -12 dB to +6 dB							
	A-weighted	93	101	-	91	101	-	dB
	unweighted	90	98	-	88	98	-	dB
(Note 13)	40 kHz bandwidth unweighted	-	95	-	-	95	-	dB
	PGA Setting: +12 dB Gain							
	A-weighted	89	95	-	87	95	-	dB
	unweighted	86	92	-	84	92	-	dB
(Note 13)	40 kHz bandwidth unweighted	-	89	-	-	89	-	dB
Total Harmonic Distortion + Noise	(Note 12)							
	PGA Setting: -12 dB to +6 dB							
	-1 dB	-	-92	-86	-	-92	-84	dB
	-20 dB	-	-78	-	-	-78	-	dB
	-60 dB	-	-38	-	-	-38	-	dB
(Note 13)	40 kHz bandwidth -1 dB	-	-84	-	-	-84	-	dB
	PGA Setting: +12 dB Gain							
	-1 dB	-	-89	-83	-	-89	-81	dB
	-20 dB	-	-72	-	-	-72	-	dB
	-60 dB	-	-32	-	-	-32	-	dB
(Note 13)	40 kHz bandwidth -1 dB	-	-81	-	-	-81	-	dB

**Line-Level Inputs**

Parameter	Symbol	Commercial Grade			Automotive Grade			Unit
		Min	Typ	Max	Min	Typ	Max	
Interchannel Isolation		-	90	-	-	90	-	dB
<b>DC Accuracy</b>								
Gain Error		-	-	±10	-	-	±10	%
Gain Drift		-	±100	-	-	±100	-	ppm/°C
<b>Line-Level Input Characteristics</b>								
Full-scale Input Voltage		0.51*VA	0.57*VA	0.63*VA	0.51*VA	0.57*VA	0.63*VA	V <sub>pp</sub>
Input Impedance (Note 11)		6.12	6.8	7.48	5.44	6.8	8.16	kΩ
Maximum Interchannel Input Impedance Mismatch		-	5	-	-	5	-	%

**Line-Level and Microphone-Level Inputs**

Parameter	Symbol	Commercial Grade			Automotive Grade			Unit
		Min	Typ	Max	Min	Typ	Max	
<b>DC Accuracy</b>								
Interchannel Gain Mismatch		-	0.1	-	-	0.1	-	dB
<b>Programmable Gain Characteristics</b>								
Gain Step Size		-	0.5	-	-	0.5	-	dB
Absolute Gain Step Error		-	-	0.4	-	-	0.4	dB

11. Valid when the line-level inputs are selected.

## ADC ANALOG CHARACTERISTICS

(Continued)

Microphone-Level Inputs								
Parameter	Symbol	Commercial Grade			Automotive Grade			Unit
		Min	Typ	Max	Min	Typ	Max	
<b>Dynamic Performance for VA = 4.75 V to 5.25 V</b>								
Dynamic Range								
PGA Setting: -12 dB to 0 dB								
A-weighted		77	83	-	75	83	-	dB
unweighted		74	80	-	72	80	-	dB
PGA Setting: +12 dB								
A-weighted		65	71	-	63	71	-	dB
unweighted		62	68	-	60	68	-	dB
Total Harmonic Distortion + Noise (Note 12)								
PGA Setting: -12 dB to 0 dB								
-1 dB	THD+N	-	-80	-74	-	-80	-72	dB
-20 dB		-	-60	-	-	-60	-	dB
-60 dB		-	-20	-	-	-20	-	dB
PGA Setting: +12 dB								
-1 dB		-	-68	-	-	-68	-	dB
<b>Dynamic Performance for VA = 3.13 V to 3.46 V</b>								
Dynamic Range								
PGA Setting: -12 dB to 0 dB								
A-weighted		77	83	-	75	83	-	dB
unweighted		74	80	-	72	80	-	dB
PGA Setting: +12 dB								
A-weighted		65	71	-	63	71	-	dB
unweighted		62	68	-	60	68	-	dB
Total Harmonic Distortion + Noise (Note 12)								
PGA Setting: -12 dB to 0 dB								
-1 dB	THD+N	-	-80	-74	-	-80	-72	dB
-20 dB		-	-60	-	-	-60	-	dB
-60 dB		-	-20	-	-	-20	-	dB
PGA Setting: +12 dB								
-1 dB		-	-68	-	-	-68	-	dB
Interchannel Isolation		-	80	-	-	80	-	dB
<b>DC Accuracy</b>								
Gain Error		-	±5	-	-	±5	-	%
Gain Drift		-	±300	-	-	±300	-	ppm/°C
<b>Microphone-Level Input Characteristics</b>								
Full-scale Input Voltage		0.013*VA	0.017*VA	0.021*VA	0.013*VA	0.017*VA	0.021*VA	V <sub>pp</sub>
Input Impedance (Note 14)		-	60	-	-	60	-	kΩ

12. Referred to the typical line-level full-scale input voltage

13. Valid for Double- and Quad-Speed Modes only.

14. Valid when the microphone-level inputs are selected.

**ADC DIGITAL FILTER CHARACTERISTICS**

Parameter (Notes 15, 17)	Symbol	Min	Typ	Max	Unit
<b>Single-Speed Mode</b>					
Passband (-0.1 dB)		0	-	0.4896	Fs
Passband Ripple		-	-	0.035	dB
Stopband		0.5688	-	-	Fs
Stopband Attenuation		70	-	-	dB
Total Group Delay (Fs = Output Sample Rate)	$t_{gd}$	-	12/Fs	-	s
<b>Double-Speed Mode</b>					
Passband (-0.1 dB)		0	-	0.4896	Fs
Passband Ripple		-	-	0.025	dB
Stopband		0.5604	-	-	Fs
Stopband Attenuation		69	-	-	dB
Total Group Delay (Fs = Output Sample Rate)	$t_{gd}$	-	9/Fs	-	s
<b>Quad-Speed Mode</b>					
Passband (-0.1 dB)		0	-	0.2604	Fs
Passband Ripple		-	-	0.025	dB
Stopband		0.5000	-	-	Fs
Stopband Attenuation		60	-	-	dB
Total Group Delay (Fs = Output Sample Rate)	$t_{gd}$	-	5/Fs	-	s
<b>High-Pass Filter Characteristics</b>					
Frequency Response	-3.0 dB		-	1	Hz
	-0.13 dB	(Note 16)		20	Hz
Phase Deviation	@ 20 Hz	(Note 16)		10	Deg
Passband Ripple				0	dB
Filter Settling Time				$10^5/Fs$	s

15. Filter response is guaranteed by design.

16. Response shown is for Fs = 48 kHz.

17. Response is clock-dependent and will scale with Fs. Note that the response plots (Figures 30 to 41) are normalized to Fs and can be de-normalized by multiplying the X-axis scale by Fs.



## DC ELECTRICAL CHARACTERISTICS

AGND = DGND = 0 V, all voltages with respect to ground. MCLK=12.288 MHz; Fs=48 kHz; Master Mode.

Parameter	Symbol	Min	Typ	Max	Unit	
Power Supply Current (Normal Operation)	VA = 5 V	IA	-	41	50	mA
	VA = 3.3 V	IA	-	37	45	mA
	VD, VLS, VLC = 5 V	ID	-	39	47	mA
	VD, VLS, VLC = 3.3 V	ID	-	23	28	mA
Power Supply Current (Power-Down Mode) (Note 18)	VA = 5 V	IA	-	0.50	-	mA
	VLS, VLC, VD=5 V	ID	-	0.54	-	mA
Power Consumption (Normal Operation)	VA, VD, VLS, VLC = 5 V	-	-	400	485	mW
	VA, VD, VLS, VLC = 3.3 V	-	-	198	241	mW
	(Power-Down Mode)	VA, VD, VLS, VLC = 5 V	-	4.2	-	mW
Power Supply Rejection Ratio (1 kHz)	(Note 19)	PSRR	-	55	-	dB
<b>VQ Characteristics</b>						
Quiescent Voltage	(Note 20)	VQ	-	0.5 x VA	-	VDC
DC Current from VQ	(Note 20)	IQ	-	-	1	μA
VQ Output Impedance		ZQ	-	4.5	-	kΩ
FILT+ Nominal Voltage		FILT+	-	VA	-	VDC
Microphone Bias Voltage		MICBIAS	-	0.8 x VA	-	VDC
Current from MICBIAS		IMB	-	-	2	mA

18. Power-Down Mode is defines as  $\overline{\text{RESET}} = \text{Low}$  with all clock and data lines held static and no analog input.
19. Valid with the recommended capacitor values on FILT+ and VQ as shown in the Typical Connection Diagram.
20. Guaranteed by design. The DC current draw represents the allowed current draw due to typical leakage through the electrolytic de-coupling capacitors.

## DIGITAL INTERFACE CHARACTERISTICS

Test conditions (unless otherwise specified): AGND = DGND = 0 V; VLS = VLC = 1.71 V to 5.25 V.

Parameters (Note 21)	Symbol	Min	Typ	Max	Units
High-Level Input Voltage VL = 1.71 V Serial Port Control Port VL > 2.0 V Serial Port Control Port	V <sub>IH</sub>	0.8xVLS	-	-	V
	V <sub>IH</sub>	0.8xVLC	-	-	V
	V <sub>IH</sub>	0.7xVLS	-	-	V
	V <sub>IH</sub>	0.7xVLC	-	-	V
Low-Level Input Voltage Serial Port Control Port	V <sub>IL</sub>	-	-	0.2xVLS	V
	V <sub>IL</sub>	-	-	0.2xVLC	V
High-Level Output Voltage at I <sub>o</sub> = 2 mA Serial Port Control Port MUTEC TXOUT	V <sub>OH</sub>	VLS-1.0	-	-	V
	V <sub>OH</sub>	VLC-1.0	-	-	V
	V <sub>OH</sub>	VA-1.0	-	-	V
	V <sub>OH</sub>	VD-1.0	-	-	V
Low-Level Output Voltage at I <sub>o</sub> = 2 mA Serial Port Control Port MUTEC TXOUT	V <sub>OL</sub>	-	-	0.4	V
	V <sub>OL</sub>	-	-	0.4	V
	V <sub>OL</sub>	-	-	0.4	V
	V <sub>OL</sub>	-	-	0.4	V
Input Leakage Current	I <sub>in</sub>	-	-	±10	μA
Input Capacitance	(Note 22)	-	-	1	pF
Maximum MUTEC Drive Current		-	3	-	mA

21. Serial Port signals include: MCLK, SCLK, LRCK, SDIN1, SDIN2, TXSDIN, SDOUT.  
Control Port signals include: SCL, SDA, RESET.

22. Guaranteed by design.

## SWITCHING CHARACTERISTICS - SERIAL AUDIO PORT

Logic '0' = DGND = AGND = 0 V; Logic '1' = VL, C<sub>L</sub> = 20 pF. (Note 23)

Parameter	Symbol	Min	Typ	Max	Unit	
Sample Rate	Single-Speed Mode	F <sub>s</sub>	4	-	50	kHz
	Double-Speed Mode	F <sub>s</sub>	50	-	100	kHz
	Quad-Speed Mode	F <sub>s</sub>	100	-	200	kHz
<b>MCLK Specifications</b>						
MCLK Frequency	fmclk	1.024	-	51.200	MHz	
MCLK Input Pulse Width High/Low	tclkhl	8	-	-	ns	
MCLK Output Duty Cycle		45	50	55	%	
<b>Master Mode</b>						
LRCK Duty Cycle		-	50	-	%	
SCLK Duty Cycle		-	50	-	%	
SCLK falling to LRCK edge	t <sub>slr</sub>	-10	-	10	ns	
SCLK falling to SDOUT valid	t <sub>sdo</sub>	0	-	36	ns	
SDIN valid to SCLK rising setup time	t <sub>sdis</sub>	16	-	-	ns	
SCLK rising to SDIN hold time	t <sub>sdiH</sub>	20	-	-	ns	
<b>Slave Mode</b>						
LRCK Duty Cycle		40	50	60	%	
SCLK Period	Single-Speed Mode	t <sub>sclkw</sub>	$\frac{10^9}{(128)F_s}$	-	-	ns
	Double-Speed Mode	t <sub>sclkw</sub>	$\frac{10^9}{(64)F_s}$	-	-	ns
	Quad-Speed Mode	t <sub>sclkw</sub>	$\frac{10^9}{(64)F_s}$	-	-	ns
SCLK Pulse Width High	t <sub>sclkh</sub>	30	-	-	ns	
SCLK Pulse Width Low	t <sub>sclkl</sub>	48	-	-	ns	
SCLK falling to LRCK edge	t <sub>slr</sub>	-10	-	10	ns	
SCLK falling to SDOUT valid	t <sub>sdo</sub>	0	-	36	ns	
SDIN valid to SCLK rising setup time	t <sub>sdis</sub>	16	-	-	ns	
SCLK rising to SDIN hold time	t <sub>sdiH</sub>	20	-	-	ns	

23. See Figures 3 and 4 on page 20.

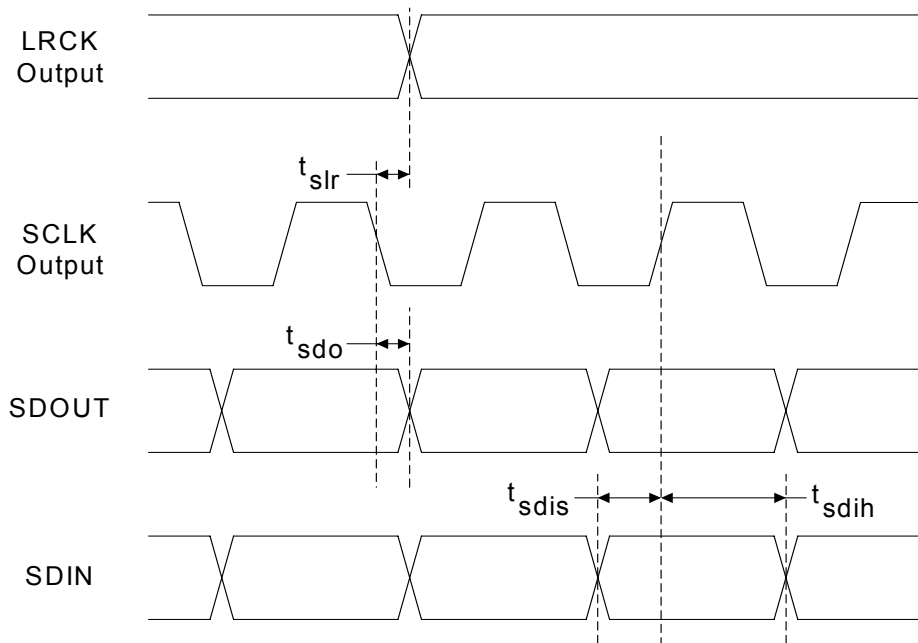

**Figure 3. Master Mode Serial Audio Port Timing**

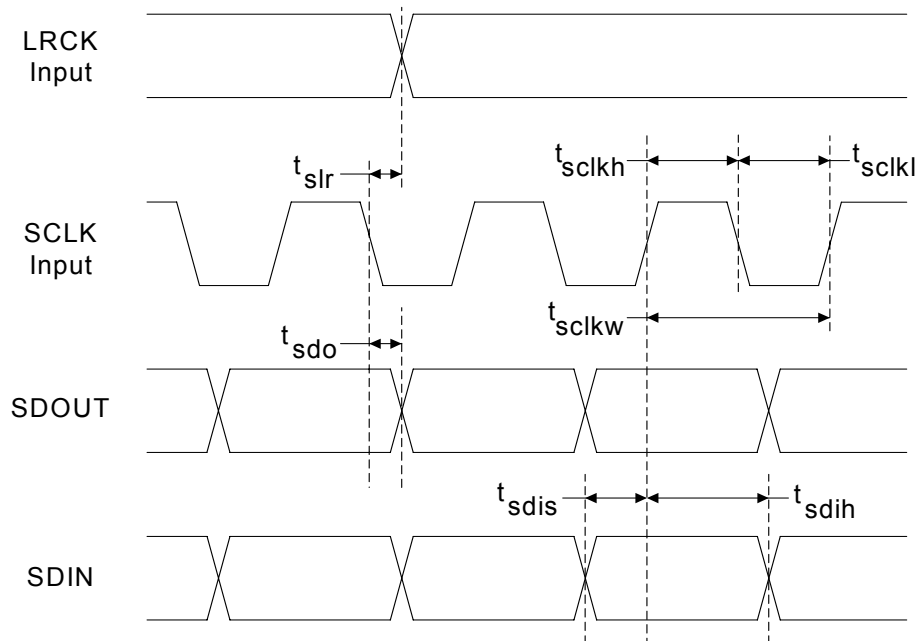

**Figure 4. Slave Mode Serial Audio Port Timing**

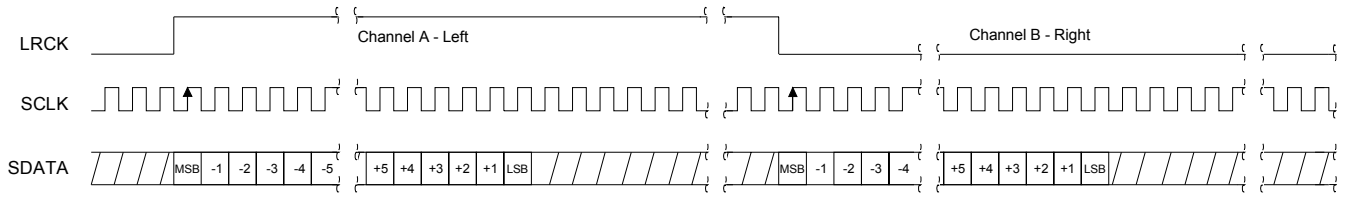

**Figure 5. Format 0, Left-Justified up to 24-Bit Data**

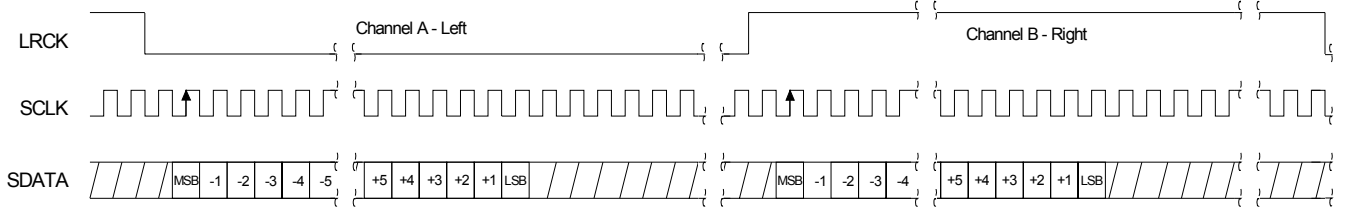

**Figure 6. Format 1, I²S up to 24-Bit Data**

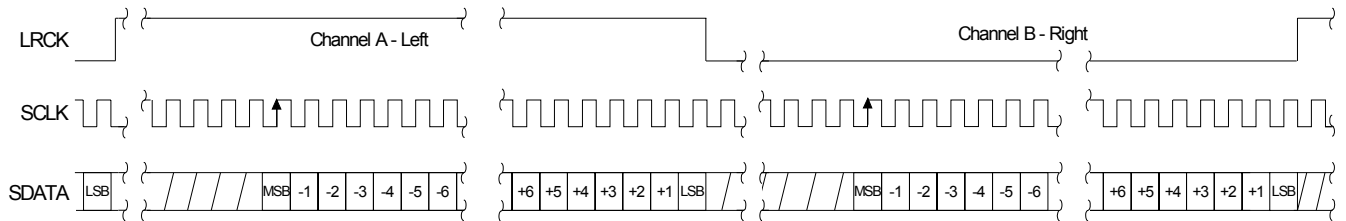

**Figure 7. Format 2, Right-Justified 16-Bit Data.  
Format 3, Right-Justified 24-Bit Data.**

## SWITCHING CHARACTERISTICS - I<sup>2</sup>C CONTROL PORT

Inputs: Logic 0 = DGND = AGND = 0 V, Logic 1 = VLC, C<sub>L</sub> = 30 pF.

Parameter	Symbol	Min	Max	Unit
SCL Clock Frequency	f <sub>scl</sub>	-	100	kHz
RESET Rising Edge to Start	t <sub>irs</sub>	500	-	ns
Bus Free Time Between Transmissions	t <sub>buf</sub>	4.7	-	μs
Start Condition Hold Time (prior to first clock pulse)	t <sub>hdst</sub>	4.0	-	μs
Clock Low time	t <sub>low</sub>	4.7	-	μs
Clock High Time	t <sub>high</sub>	4.0	-	μs
Setup Time for Repeated Start Condition	t <sub>sust</sub>	4.7	-	μs
SDA Hold Time from SCL Falling	(Note 24) t <sub>hdd</sub>	0	-	μs
SDA Setup time to SCL Rising	t <sub>sud</sub>	250	-	ns
Rise Time of SCL and SDA	(Note 25) t <sub>rc</sub> , t <sub>rd</sub>	-	1	μs
Fall Time SCL and SDA	(Note 25) t <sub>fc</sub> , t <sub>fd</sub>	-	300	ns
Setup Time for Stop Condition	t <sub>susp</sub>	4.7	-	μs
Acknowledge Delay from SCL Falling	t <sub>ack</sub>	300	1000	ns

24. Data must be held for sufficient time to bridge the transition time, t<sub>fc</sub>, of SCL.

25. Guaranteed by design.

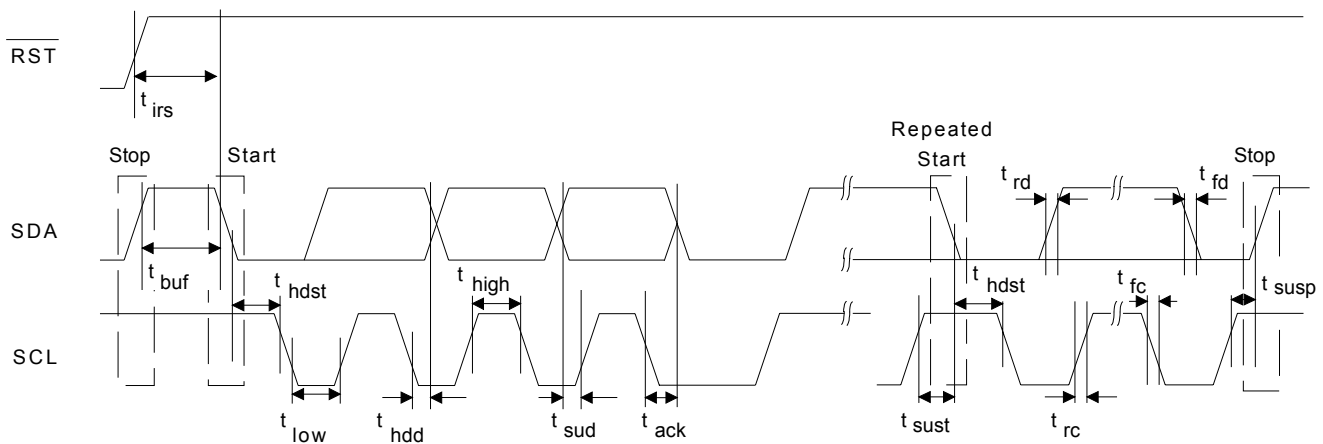
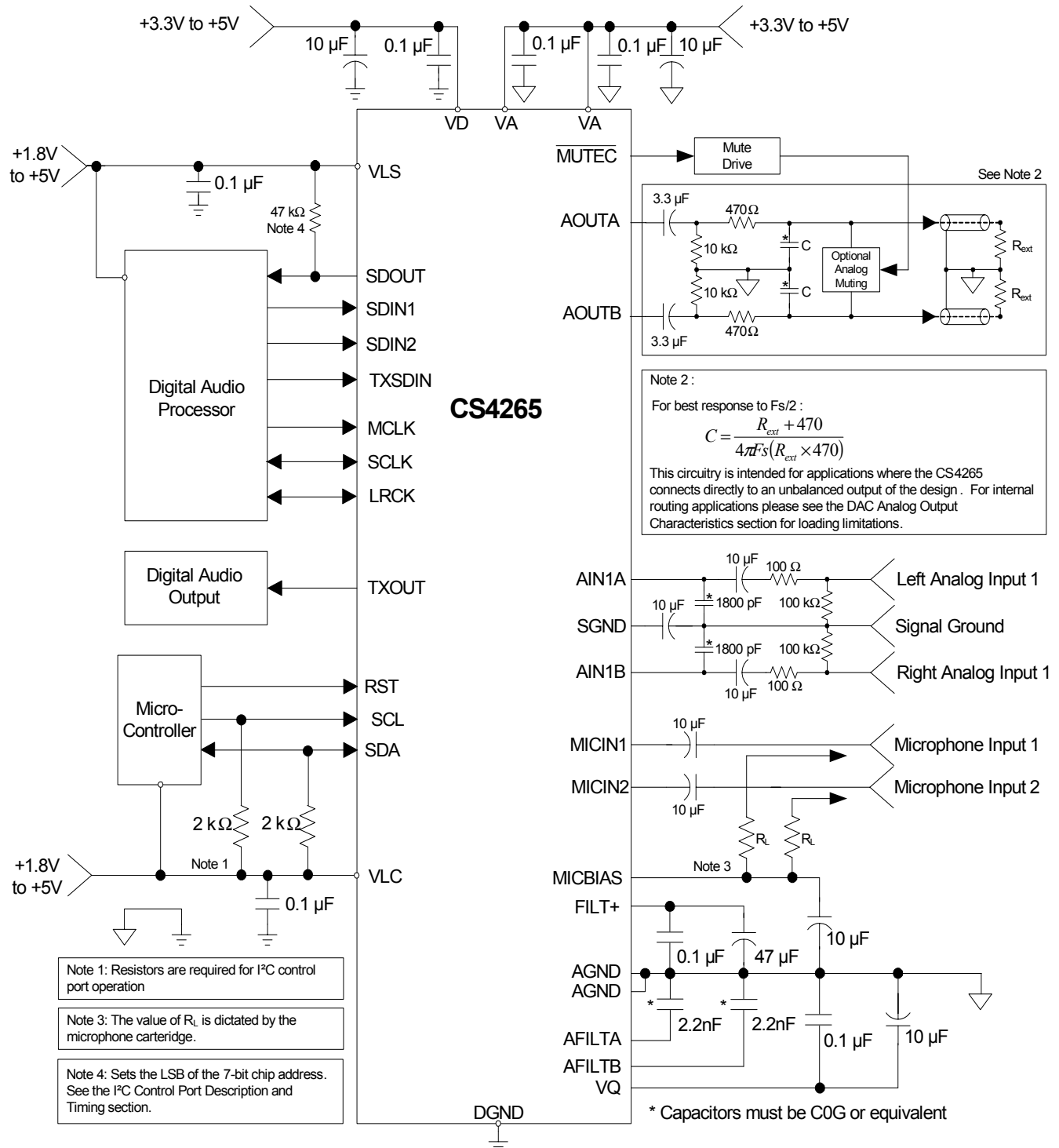

Figure 8. Control Port Timing - I<sup>2</sup>C Format

### 3. TYPICAL CONNECTION DIAGRAM



**Figure 9. Typical Connection Diagram**

## 4. APPLICATIONS

### 4.1 Recommended Power-Up Sequence

1. Hold  $\overline{\text{RESET}}$  low until the power supply, MCLK, and LRCK are stable. In this state, the Control Port is reset to its default settings.
2. Bring  $\overline{\text{RESET}}$  high. The device will remain in a low power state with the PDN bit set by default. The control port will be accessible.
3. The desired register settings can be loaded while the PDN bit remains set.
4. Clear the PDN bit to initiate the power-up sequence.

### 4.2 System Clocking

The CS4265 will operate at sampling frequencies from 4 kHz to 200 kHz. This range is divided into three speed modes as shown in [Table 1](#).

Mode	Sampling Frequency
<i>Single-Speed</i>	4-50 kHz
<i>Double-Speed</i>	50-100 kHz
<i>Quad-Speed</i>	100-200 kHz

Table 1. Speed Modes

#### 4.2.1 Master Clock

MCLK/LRCK must maintain an integer ratio as shown in [Table 2](#). The LRCK frequency is equal to  $F_s$ , the frequency at which audio samples for each channel are clocked into or out of the device. The FM bits (See “[Functional Mode \(Bits 7:6\)](#)” on page 37.) and the MCLK Freq bits (See “[MCLK Frequency - Address 05h](#)” on page 38.) configure the device to generate the proper clocks in Master Mode and receive the proper clocks in Slave Mode. [Table 2](#) illustrates several standard audio sample rates and the required MCLK and LRCK frequencies.

LRCK (kHz)	MCLK (MHz)								
	64x	96x	128x	192x	256x	384x	512x	768x	1024x
32	-	-	-	-	8.1920	12.2880	16.3840	24.5760	32.7680
44.1	-	-	-	-	11.2896	16.9344	22.5792	33.8680	45.1584
48	-	-	-	-	12.2880	18.4320	24.5760	36.8640	49.1520
64	-	-	8.1920	12.2880	16.3840	24.5760	32.7680	-	-
88.2	-	-	11.2896	16.9344	22.5792	33.8680	45.1584	-	-
96	-	-	12.2880	18.4320	24.5760	36.8640	49.1520	-	-
128	8.1920	12.2880	16.3840	24.5760	32.7680	-	-	-	-
176.4	11.2896	16.9344	22.5792	33.8680	45.1584	-	-	-	-
192	12.2880	18.4320	24.5760	36.8640	49.1520	-	-	-	-
Mode	QSM					DSM		SSM	

Table 2. Common Clock Frequencies



### 4.2.2 Master Mode

As a clock master, LRCK and SCLK will operate as outputs. LRCK and SCLK are internally derived from MCLK with LRCK equal to  $F_s$  and SCLK equal to  $64 \times F_s$  as shown in Figure 10.

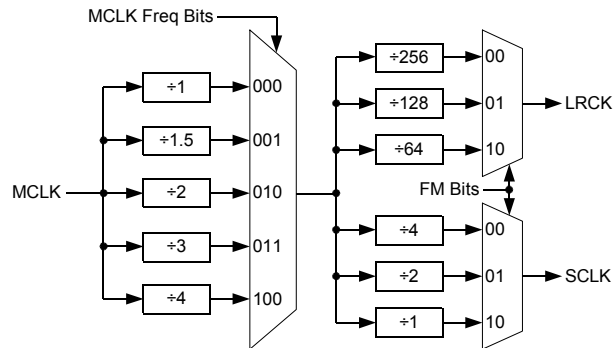

**Figure 10. Master Mode Clocking**

### 4.2.3 Slave Mode

In Slave Mode, SCLK and LRCK operate as inputs. The Left/Right clock signal must be equal to the sample rate,  $F_s$ , and must be synchronously derived from the supplied master clock, MCLK.

The serial bit clock, SCLK, must be synchronously derived from the master clock, MCLK, and be equal to  $128x$ ,  $64x$ ,  $48x$  or  $32x$   $F_s$ , depending on the desired speed mode. Refer to Table 3 for required clock ratios.

	Single-Speed	Double-Speed	Quad-Speed
SCLK/LRCK Ratio	32x, 48x, 64x, 128x	32x, 48x, 64x	32x, 48x, 64x

**Table 3. Slave Mode Serial Bit Clock Ratios**

## 4.3 High-Pass Filter and DC Offset Calibration

When using operational amplifiers in the input circuitry driving the CS4265, a small DC offset may be driven into the A/D converter. The CS4265 includes a high-pass filter after the decimator to remove any DC offset which could result in recording a DC level, possibly yielding clicks when switching between devices in a multichannel system.

The high-pass filter continuously subtracts a measure of the DC offset from the output of the decimation filter. If the HPFFreeze bit (See “ADC High-Pass Filter Freeze (Bit 1)” on page 38.) is set during normal operation, the current value of the DC offset for the each channel is frozen and this DC offset will continue to be subtracted from the conversion result. This feature makes it possible to perform a system DC offset calibration by:

1. Running the CS4265 with the high-pass filter enabled until the filter settles. See the ADC Digital Filter Characteristics section for filter settling time.
2. Disabling the high-pass filter and freezing the stored DC offset.

A system calibration performed in this way will eliminate offsets anywhere in the signal path between the calibration point and the CS4265.

## 4.4 Analog Input Multiplexer, PGA, and Mic Gain

The CS4265 contains a stereo 2-to-1 analog input multiplexer followed by a programmable gain amplifier (PGA). The input multiplexer is able to select either a line-level input source, or a mic-level input source, and route it to the PGA. The mic-level input passes through a +32 dB gain stage prior to the input multiplexer, allowing it to be used for microphone-level signals without the need for any external gain. The PGA stage provides 12 dB of gain or attenuation in 0.5 dB steps. [Figure 11](#) shows the architecture of the input multiplexer, PGA, and mic gain stages.

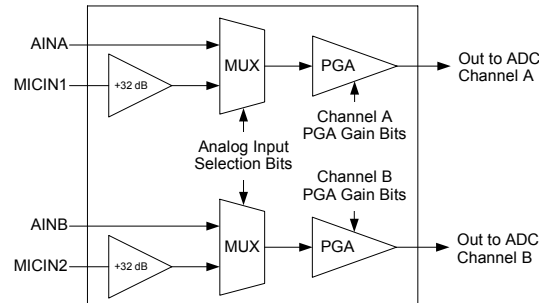

**Figure 11. Analog Input Architecture**

The [“Analog Input Selection \(Bit 0\)” on page 40](#) outlines the bit settings necessary to control the input multiplexer and mic gain. [“Channel B PGA Control - Address 07h” on page 39](#) and [“Channel A PGA Control - Address 08h” on page 39](#) outline the register settings necessary to control the PGA. By default, the line-level input is selected by the input multiplexer, and the PGA is set to 0 dB.

## 4.5 Input Connections

The analog modulator samples the input at 6.144 MHz (MCLK=12.288 MHz). The digital filter will reject signals within the stopband of the filter. However, there is no rejection for input signals which are  $(n \times 6.144 \text{ MHz})$  the digital passband frequency, where  $n=0,1,2,\dots$ . Refer to the Typical Connection Diagram for the recommended analog input circuit that will attenuate noise energy at 6.144 MHz. The use of capacitors which have a large voltage coefficient (such as general-purpose ceramics) must be avoided since these can degrade signal linearity. Any unused analog input pairs should be left unconnected.

### 4.5.1 Pseudo-Differential Input

The CS4265 implements a pseudo-differential input stage. The SGND input is intended to be used as a pseudo-differential reference signal. This feature allows for common mode noise rejection with single-ended signals. [Figure 12](#) shows a basic diagram outlining the internal implementation of the pseudo-differential input stage. The Typical Connection Diagram shows the recommended pseudo-differential input

topology. If pseudo-differential input functionality is not required, simply connect the SGND pin to AGND through the parallel combination of a 10  $\mu\text{F}$  and a 0.1  $\mu\text{F}$  capacitor.

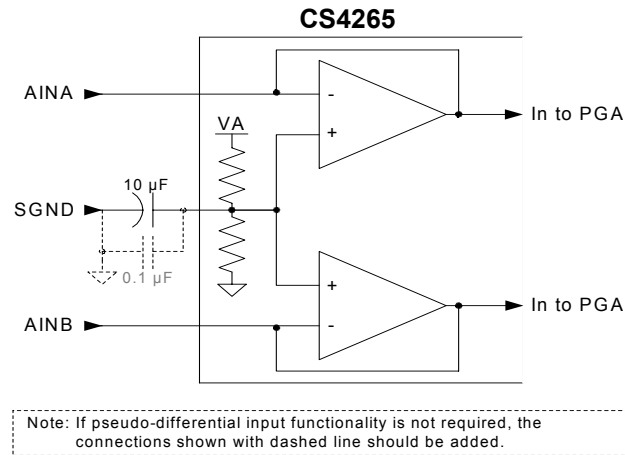

**Figure 12. Pseudo-Differential Input Stage**

## 4.6 Output Connections

The CS4265 DACs implement a switched-capacitor filter, followed by a continuous time low-pass filter. Its response, combined with that of the digital interpolator, is shown in [Section 8. “DAC Filter Plots” on page 47](#). The recommended external analog circuitry is shown in the Typical Connection Diagram.

The CS4265 DAC does not include phase or amplitude compensation for an external filter. Therefore, the DAC system phase and amplitude response is dependent on the external analog circuitry.

## 4.7 Output Transient Control

The CS4265 uses Popguard® technology to minimize the effects of output transients during power-up and power-down. This technique eliminates the audio transients commonly produced by single-ended, single-supply converters when it is implemented with external DC-blocking capacitors connected in series with the audio outputs. To make best use of this feature, it is necessary to understand its operation.

### 4.7.1 Power-Up

When the device is initially powered-up, the DAC outputs AOUTA and AOUTB are clamped to VQ, which is initially low. After the PDN bit is released (set to '0'), the outputs begin to ramp with VQ towards the nominal quiescent voltage. This ramp takes approximately 200 ms to complete. The gradual voltage ramping allows time for the external DC-blocking capacitors to charge to VQ, effectively blocking the quiescent DC voltage. Audio output will begin after approximately 2000 sample periods.

### 4.7.2 Power-Down

To prevent audio transients at power-down, the DC-blocking capacitors must fully discharge before turning off the power. In order to do this, either the PDN should be set or the device should be reset about 250 ms before removing power. During this time, the voltage on VQ and the DAC outputs will gradually discharge to GND. If power is removed before this 250 ms time period has passed, a transient will occur when the VA supply drops below that of VQ. There is no minimum time for a power cycle; power may be re-applied at any time.

### 4.7.3 Serial Interface Clock Changes

When changing the clock ratio or sample rate, it is recommended that zero data (or near zero data) be present on the selected SDIN pin for at least 10 LRCK samples before the change is made. During the

clocking change, the DAC outputs will always be in a zero-data state. If non-zero serial audio input is present at the time of switching, a slight click or pop may be heard as the DAC output automatically goes to its zero-data state.

#### 4.8 DAC Serial Data Input Multiplexer

The CS4265 contains a 2-to-1 serial data input multiplexer. This allows two separate data sources to be input into the DAC without the use of any external multiplexing components. “[Section 6.6.1 “DAC SDIN Source \(Bit 7\)” on page 39](#)” describes the control port settings necessary to control the multiplexer.

#### 4.9 De-Emphasis Filter

The CS4265 includes on-chip digital de-emphasis optimized for a sample rate of 44.1 kHz. The filter response is shown in [Figure 13](#). The frequency response of the de-emphasis curve scales proportionally with changes in sample rate,  $F_s$ . Please see [Section 6.3.3 “De-Emphasis Control \(Bit 1\)” on page 37](#) for de-emphasis control.

The de-emphasis feature is included to accommodate audio recordings that utilize 50/15  $\mu$ s pre-emphasis equalization as a means of noise reduction.

De-emphasis is only available in Single-Speed Mode.

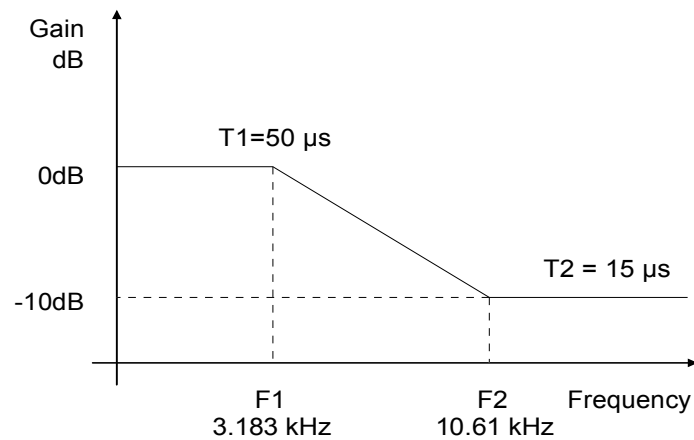

**Figure 13. De-Emphasis Curve**

#### 4.10 Internal Digital Loopback

The CS4265 supports an internal digital loopback mode in which the output of the ADC is routed to the input of the DAC. This mode may be activated by setting the LOOP bit in the Signal Selection register (See “[Signal Selection - Address 06h” section on page 39](#)”).

When this bit is set, the status of the DAC\_DIF[1:0] bits in register 03h will be disregarded by the CS4265. Any changes made to the DAC\_DIF[1:0] bits while the LOOP bit is set will have no impact on operation until the LOOP bit is cleared, at which time the Digital Interface Format of the DAC will operate according to the format selected by the DAC\_DIF[1:0] bits. While the LOOP bit is set, data will be present on the SDOOUT pin in the format selected by the ADC\_DIF bit in register 04h.

## 4.11 Mute Control

The  $\overline{\text{MUTE}}\text{C}$  pin becomes active during power-up initialization, reset, muting, if the MCLK to LRCK ratio is incorrect, and during power-down. The  $\overline{\text{MUTE}}\text{C}$  pin is intended to be used as control for an external mute circuit in order to add off-chip mute capability.

Use of the Mute Control function is not mandatory but recommended for designs requiring the absolute minimum in extraneous clicks and pops. Also, use of the Mute Control function can enable the system designer to achieve idle channel noise/signal-to-noise ratios which are only limited by the external mute circuit. The  $\overline{\text{MUTE}}\text{C}$  pin is an active-low CMOS driver. See Figure 14 for a suggested active-low mute circuit.

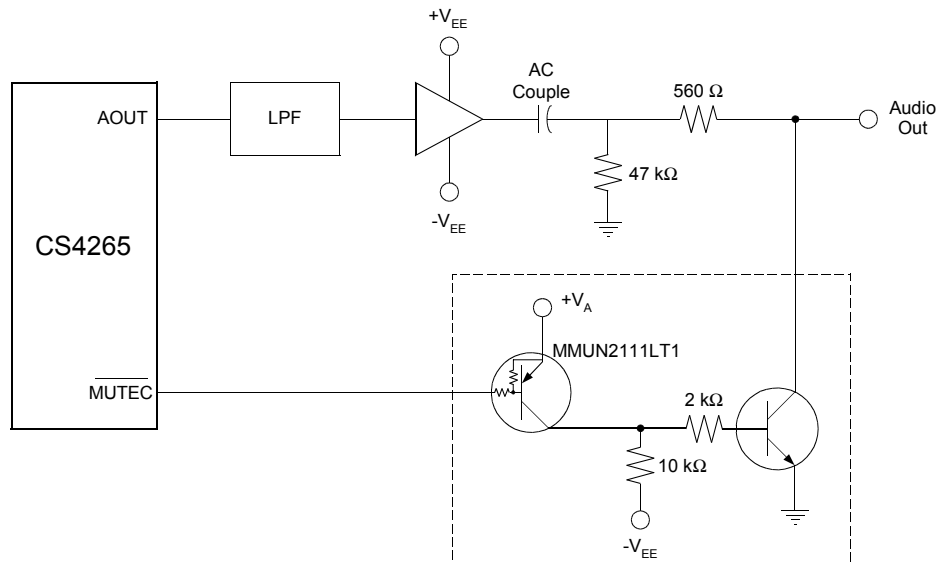

Figure 14. Suggested Active-Low Mute Circuit

## 4.12 AES3 Transmitter

The CS4265 includes an IEC60958-3 digital audio transmitter. A comprehensive buffering scheme provides write access to the channel status data. This buffering scheme is described in the “[Channel Status Buffer Management](#)” section on page 52.

The IEC60958-3 transmitter encodes and transmits audio and digital data according to the IEC60958-3 (S/PDIF) interface standard. The transmitter receives audio data from the input pin TXSDIN and control clocks from the PCM Serial Interface. Audio and control data are multiplexed together and bi-phase mark encoded. The resulting bit stream is driven from the output pin TXOUT to an output connector either directly or through a transformer. The transmitter is clocked from the clock input pin MCLK.

The channel status (C) bits in the transmitted data stream are taken from storage areas within the CS4265. The user can manually access the internal storage of the CS4265 to configure the transmitted channel status data. The “[Channel Status Buffer Management](#)” section describes the method of manually accessing the storage areas. The CS4265 transmits all ‘0’s in the user (U) data fields.

### 4.12.1 TxOut Driver

The line driver is a low skew, low impedance, single-ended output capable of driving cables directly. The driver is set to ground during reset (RESET = LOW), when no transmit clock is provided, and optionally

under the control of a register bit. The CS4265 also allows immediate muting of the IEC60958-3 transmitter audio data through a control register bit.

External components are used to terminate and isolate the external cable from the CS4265. These components are detailed in the “[External IEC60958-3 Transmitter Components](#)” section on page 51.

#### 4.12.2 Mono Mode Operation

An IEC60958-3 stream may be used in more than one way to transmit 192 kHz sample rate data. One method is to double the frame rate of the current format. This results in a stereo signal with a sample rate of 192 kHz. An alternate method is implemented using the two sub-frames in a 96 kHz frame rate IEC60958-3 signal to carry consecutive samples of a mono signal, resulting in a 192 kHz sample rate stream. This allows older equipment, whose IEC60958-3 transmitters and receivers are not rated for 192 kHz frame rate operation, to handle 192 kHz sample rate information. In this “mono mode”, two cables are needed for stereo data transfer. The CS4265 offers Mono Mode operation. The CS4265 is placed into and out of Mono Mode with the MMT control bit.

In Mono Mode, the input port will run at the audio sample rate ( $F_s$ ), while the IEC60958-3 transmitter frame rate will be at  $F_s/2$ . Consecutive left or right channel serial audio data samples may be selected for transmission on the A and B sub-frames, and the channel status block transmitted is also selectable.

Using Mono Mode is only necessary if the incoming audio sample rate is already at 192 kHz and contains both left and right audio data words. The “Mono Mode” IEC60958-3 output stream may also be achieved by keeping the CS4265 in normal stereo mode and placing consecutive audio samples in the left and right positions in an incoming 96 kHz word-rate data stream.

#### 4.13 I<sup>2</sup>C Control Port Description and Timing

The control port is used to access the registers, allowing the CS4265 to be configured for the desired operational modes and formats. The operation of the control port may be completely asynchronous with respect to the audio sample rates. However, to avoid potential interference problems, the control port pins should remain static if no operation is required.

SDA is a bidirectional data line. Data is clocked into and out of the part by the clock, SCL. A 47 k $\Omega$  pull-up or pull-down on the SDOUT pin will set AD0, the least significant bit of the chip address. A pull-up to VLS will set AD0 to ‘1’ and a pull-down to DGND will set AD0 to ‘0’. The state of the SDOUT pin is sensed and AD0 is set upon the release of RESET.

The signal timings for a read and write cycle are shown in [Figure 15](#) and [Figure 16](#). A Start condition is defined as a falling transition of SDA while the clock is high. A Stop condition is a rising transition while the clock is high. All other transitions of SDA occur while the clock is low. The first byte sent to the CS4265 after a Start condition consists of a 7-bit chip address field and an R/W bit (high for a read, low for a write). The upper 6 bits of the 7-bit address field are fixed at 100111. To communicate with a CS4265, the chip address field, which is the first byte sent to the CS4265, should match 100111 followed by the setting of AD0. The eighth bit of the address is the R/W bit. If the operation is a write, the next byte is the Memory Address Pointer (MAP), which selects the register to be read or written. If the operation is a read, the contents of the register pointed to by the MAP will be output. Following each data byte, the memory address pointer will automatically increment to facilitate block reads and writes of successive registers. Each byte is separated by an acknowledge bit. The ACK bit is output from the CS4265 after each input byte is read, and is input to the CS4265 from the microcontroller after each transmitted byte.

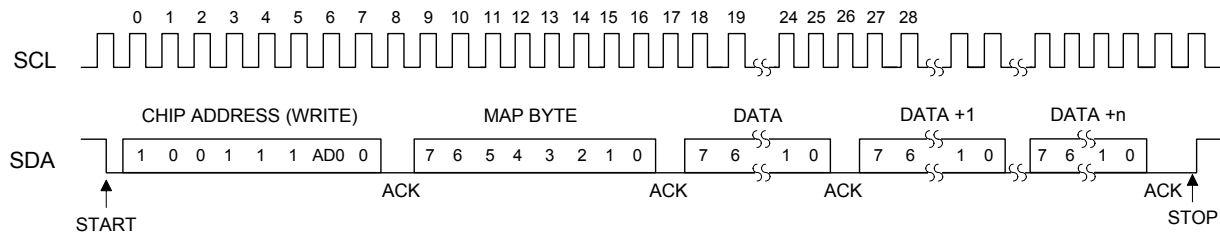

**Figure 15. Control Port Timing, I<sup>2</sup>C Write**

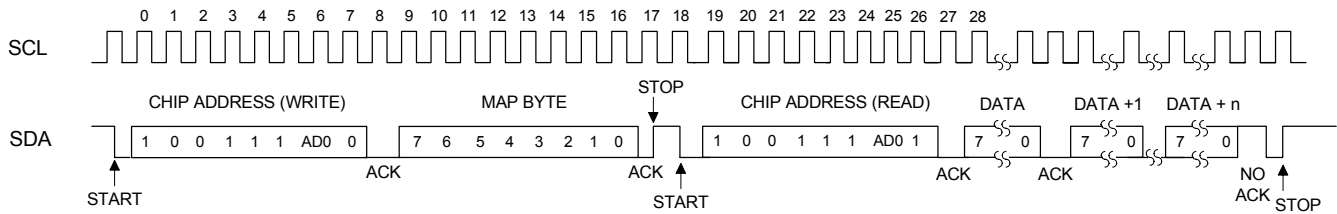

**Figure 16. Control Port Timing, I<sup>2</sup>C Read**

Since the read operation cannot set the MAP, an aborted write operation is used as a preamble. As shown in [Figure 16](#), the write operation is aborted after the acknowledge for the MAP byte by sending a stop condition. The following pseudocode illustrates an aborted write operation followed by a read operation.

- Send start condition.
- Send 100111x0 (chip address & write operation).
- Receive acknowledge bit.
- Send MAP byte.
- Receive acknowledge bit.
- Send stop condition, aborting write.
- Send start condition.
- Send 100111x1(chip address & read operation).
- Receive acknowledge bit.
- Receive byte, contents of selected register.
- Send acknowledge bit.
- Send stop condition.

#### 4.14 Status Reporting

The CS4265 has comprehensive status reporting capabilities. Many conditions can be reported in the status register, as listed in the status register descriptions. See [“Status - Address 0Dh” on page 42](#). Each source may be masked off through mask register bits. In addition, each source may be set to rising edge, falling edge, or level sensitive. Combined with the option of level-sensitive or edge-sensitive modes within the microcontroller, many different configurations are possible, depending on the needs of the equipment designer.

#### 4.15 Reset

When  $\overline{\text{RESET}}$  is low, the CS4265 enters a low-power mode and all internal states are reset, including the control port and registers, the outputs are muted. When  $\overline{\text{RESET}}$  is high, the control port becomes operational, and the desired settings should be loaded into the control registers. Writing a 0 to the PDN bit in the Power Control register will then cause the part to leave the low-power state and begin operation.

The delta-sigma modulators settle in a matter of microseconds after the analog section is powered, either through the application of power or by setting the  $\overline{\text{RESET}}$  pin high. However, the voltage reference will take much longer to reach a final value due to the presence of external capacitance on the FILT+ pin. During this voltage reference ramp delay, both SDOOUT and DAC outputs will be automatically muted.

It is recommended that  $\overline{\text{RESET}}$  be activated if the analog or digital supplies drop below the recommended operating condition to prevent power-glitch-related issues.

#### 4.16 Synchronization of Multiple Devices

In systems where multiple ADCs are required, care must be taken to achieve simultaneous sampling. To ensure synchronous sampling, the master clocks and left/right clocks must be the same for all of the CS4265s in the system. If only one master clock source is needed, one solution is to place one CS4265 in Master Mode, and slave all of the other CS4265s to the one master. If multiple master clock sources are needed, a possible solution would be to supply all clocks from the same external source and time the CS4265 reset with the inactive edge of master clock. This will ensure that all converters begin sampling on the same clock edge.

#### 4.17 Grounding and Power Supply Decoupling

As with any high-resolution converter, the CS4265 requires careful attention to power supply and grounding arrangements if its potential performance is to be realized. [Figure 9](#) shows the recommended power arrangements, with VA connected to a clean supply. VD, which powers the digital filter, may be run from the system logic supply (VLS or VLC) or may be powered from the analog supply (VA) via a resistor. In this case, no additional devices should be powered from VD. Power supply decoupling capacitors should be as near to the CS4265 as possible, with the low value ceramic capacitor being the nearest. All signals, especially clocks, should be kept away from the FILT+ and VQ pins in order to avoid unwanted coupling into the modulators. The FILT+ and VQ decoupling capacitors, particularly the 0.1  $\mu\text{F}$ , must be positioned to minimize the electrical path from FILT+ and AGND. The CS4265 evaluation board demonstrates the optimum layout and power supply arrangements. To minimize digital noise, connect the CS4265 digital outputs only to CMOS inputs.

#### 4.18 Package Considerations

The CS4265 is available in the compact QFN package. The under side of the QFN package reveals a large metal pad that serves as a thermal relief to provide for maximum heat dissipation. This pad must mate with an equally dimensioned copper pad on the PCB and must be electrically connected to ground. A series of vias should be used to connect this copper pad to one or more larger ground planes on other PCB layers. In split ground systems, it is recommended that this thermal pad be connected to AGND for best performance. The CS4265 evaluation board demonstrates the optimum thermal pad and via configuration.



## 5. REGISTER QUICK REFERENCE

This table shows the register names and their associated default values.

Addr	Function	7	6	5	4	3	2	1	0
01h	Chip ID	PART3	PART2	PART1	PART0	REV3	REV2	REV1	REV0
		1	1	0	1	0	0	0	1
02h	Power Control	Freeze	Reserved	Reserved	Reserved	PDN_MIC	PDN_ADC	PDN_DAC	PDN
		0	0	0	0	0	0	0	1
03h	DAC Control 1	Reserved	Reserved	DAC_DIF1	DAC_DIF0	Reserved	MuteDAC	DeEmph	Reserved
		0	0	0	0	1	0	0	0
04h	ADC Control	FM1	FM0	Reserved	ADC_DIF	Reserved	MuteADC	HPFFreeze	M/S
		0	0	0	0	0	0	0	0
05h	MCLK Frequency	Reserved	MCLK Freq2	MCLK Freq1	MCLK Freq0	Reserved	Reserved	Reserved	Reserved
		0	0	0	0	0	0	0	0
06h	Signal Selection	SDINSel	Reserved	Reserved	Reserved	Reserved	Reserved	LOOP	Reserved
		0	1	0	0	0	0	0	0
07h	PGA Ch B Gain Control	Reserved	Reserved	Gain5	Gain4	Gain3	Gain2	Gain1	Gain0
		0	0	0	0	0	0	0	0
08h	PGA Ch A Gain Control	Reserved	Reserved	Gain5	Gain4	Gain3	Gain2	Gain1	Gain0
		0	0	0	0	0	0	0	0
09h	Analog Input Control	Reserved	Reserved	Reserved	PGASoft	PGAZero	Reserved	Reserved	Select
		0	0	0	1	1	0	0	1
0Ah	DAC Ch A Volume Control	Vol7	Vol6	Vol5	Vol4	Vol3	Vol2	Vol1	Vol0
		0	0	0	0	0	0	0	0
0Bh	DAC Ch B Volume Control	Vol7	Vol6	Vol5	Vol4	Vol3	Vol2	Vol1	Vol0
		0	0	0	0	0	0	0	0
0Ch	DAC Control 2	DACSoft	DACZero	InvertDAC	Reserved	Reserved	Reserved	Reserved	Reserved
		1	1	0	0	0	0	0	0
0Dh	Status	Reserved	Reserved	Reserved	EFTC	ClkErr	Reserved	ADCOvf1	ADCUndrf1
		0	0	0	0	0	0	0	0
0Eh	Status Mask	Reserved	Reserved	Reserved	EFTCM	ClkErrM	Reserved	ADCOvf1M	ADCUndrf1M
		0	0	0	0	0	0	0	0
0Fh	Status Mode MSB	Reserved	Reserved	Reserved	EFTC1	ClkErr1	Reserved	ADCOvf1	ADCUndrf1
		0	0	0	0	0	0	0	0
10h	Status Mode LSB	Reserved	Reserved	Reserved	EFTC0	ClkErr0	Reserved	ADCOvf0	ADCUndrf0
		0	0	0	0	0	0	0	0

Addr	Function	7	6	5	4	3	2	1	0
11h	Transmitter Control 1	Reserved	EFTCI	CAM	Reserved	Reserved	Reserved	Reserved	Reserved
		0	0	0	0	0	0	0	0
12h	Transmitter Control 2	Tx_DIF1	Tx_DIF0	TxOff	TxMute	V	MMT	MMTCS	MMTLR
		0	0	0	0	0	0	0	0
13h - 2Ah	C-Data Buffer	-	-	-	-	-	-	-	-

## 6. REGISTER DESCRIPTION

### 6.1 Chip ID - Register 01h

7	6	5	4	3	2	1	0
PART3	PART2	PART1	PART0	REV3	REV2	REV1	REV0

Function:

This register is Read-Only. Bits 7 through 4 are the part number ID, which is 1101b (0Dh), and the remaining bits (3 through 0) indicate the device revision as shown in [Table 4](#) below.

REV[2:0]	Revision
001	A
010	B, C0
011	C1

**Table 4. Device Revision**

### 6.2 Power Control - Address 02h

7	6	5	4	3	2	1	0
Freeze	Reserved	Reserved	Reserved	PDN_MIC	PDN_ADC	PDN_DAC	PDN

#### 6.2.1 Freeze (Bit 7)

Function:

This function allows modifications to be made to certain control port bits without the changes taking effect until the Freeze bit is disabled. To make multiple changes to these bits take effect simultaneously, set the Freeze bit, make all changes, then clear the Freeze bit. The bits affected by the Freeze function are listed in [Table 5](#).

Name	Register	Bit(s)
MuteDAC	03h	2
MuteADC	04h	2
Gain[5:0]	07h	5:0
Gain[5:0]	08h	5:0
Vol[7:0]	0Ah	7:0
Vol[7:0]	0Bh	7:0
TxMute	0Eh	4

**Table 5. Freeze-able Bits**

#### 6.2.2 Power-Down MIC (Bit 3)

Function:

The microphone preamplifier block will enter a low-power state whenever this bit is set.

#### 6.2.3 Power-Down ADC (Bit 2)

Function:

The ADC pair will remain in a reset state whenever this bit is set.

### 6.2.4 Power-Down DAC (Bit 1)

Function:

The DAC pair will remain in a reset state whenever this bit is set.

### 6.2.5 Power-Down Device (Bit 0)

Function:

The device will enter a low-power state whenever this bit is set. The power-down bit is set by default and must be cleared before normal operation can occur. The contents of the control registers are retained when the device is in power-down.

## 6.3 DAC Control - Address 03h

7	6	5	4	3	2	1	0
Reserved	Reserved	DAC_DIF1	DAC_DIF0	Reserved	MuteDAC	DeEmph	Reserved

### 6.3.1 DAC Digital Interface Format (Bits 5:4)

Function:

The required relationship between LRCK, SCLK and SDIN for the DAC is defined by the DAC Digital Interface Format and the options are detailed in [Table 6](#) and [Figures 5-7](#).

DAC_DIF1	DAC_DIF0	Description	Format	Figure
0	0	Left Justified, up to 24-bit data (default)	0	<a href="#">5</a>
0	1	I <sup>2</sup> S, up to 24-bit data	1	<a href="#">6</a>
1	0	Right-Justified, 16-bit Data	2	<a href="#">7</a>
1	1	Right-Justified, 24-bit Data	3	<a href="#">7</a>

**Table 6. DAC Digital Interface Formats**

### 6.3.2 Mute DAC (Bit 2)

Function:

The DAC outputs will mute and the  $\overline{\text{MUTE C}}$  pin will become active when this bit is set. Though this bit is active high, it should be noted that the  $\overline{\text{MUTE C}}$  pin is active low. The common mode voltage on the outputs will be retained when this bit is set. The muting function is effected, similar to attenuation changes, by the DACSoft and DACZero bits in the DAC Control 2 register.

### 6.3.3 De-Emphasis Control (Bit 1)

Function:

The standard 50/15  $\mu$ s digital de-emphasis filter response, [Figure 17](#), may be implemented for a sample rate of 44.1 kHz when the DeEmph bit is configured as shown in [Table 7](#). NOTE: De-emphasis is available only in Single-Speed Mode.

DeEmph	Description
0	Disabled (default)
1	44.1 kHz de-emphasis

**Table 7. De-Emphasis Control**

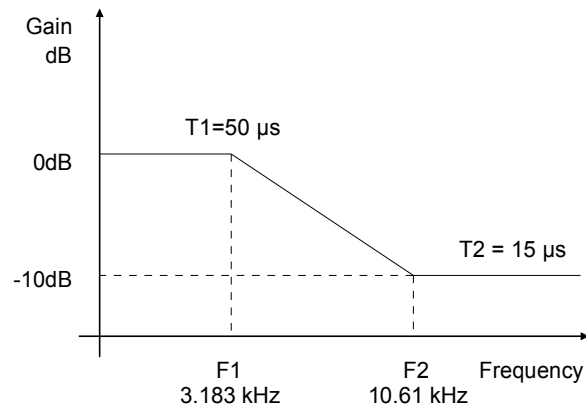

**Figure 17. De-Emphasis Curve**

## 6.4 ADC Control - Address 04h

7	6	5	4	3	2	1	0
FM1	FM0	Reserved	ADC_DIF	Reserved	MuteADC	HPFFreeze	M/S

### 6.4.1 Functional Mode (Bits 7:6)

Function:

Selects the required range of sample rates.

FM1	FM0	Mode
0	0	Single-Speed Mode: 4 to 50 kHz sample rates
0	1	Double-Speed Mode: 50 to 100 kHz sample rates
1	0	Quad-Speed Mode: 100 to 200 kHz sample rates
1	1	Reserved

**Table 8. Functional Mode Selection**

### 6.4.2 ADC Digital Interface Format (Bit 4)

Function:

The required relationship between LRCK, SCLK and SDOUT is defined by the ADC Digital Interface Format bit. The options are detailed in [Table 9](#) and may be seen in [Figure 5](#) and [Figure 6](#).

ADC_DIF	Description	Format	Figure
0	Left-Justified, up to 24-bit data (default)	0	5
1	I <sup>2</sup> S, up to 24-bit data	1	6

**Table 9. ADC Digital Interface Formats**

### 6.4.3 Mute ADC (Bit 2)

Function:

When this bit is set, the serial audio output of the both ADC channels is muted.

### 6.4.4 ADC High-Pass Filter Freeze (Bit 1)

Function:

When this bit is set, the internal high-pass filter is disabled. The current DC offset value will be frozen and continue to be subtracted from the conversion result. See [“High-Pass Filter and DC Offset Calibration” on page 25](#).

### 6.4.5 Master / Slave Mode (Bit 0)

Function:

This bit selects either master or slave operation for the serial audio port. Setting this bit selects Master Mode, while clearing this bit selects Slave Mode.

## 6.5 MCLK Frequency - Address 05h

7	6	5	4	3	2	1	0
Reserved	MCLK Freq2	MCLK Freq1	MCLK Freq0	Reserved	Reserved	Reserved	Reserved

### 6.5.1 Master Clock Dividers (Bits 6:4)

Function:

Sets the frequency of the supplied MCLK signal. See [Table 10](#) for the appropriate settings.

MCLK Divider	MCLK Freq2	MCLK Freq1	MCLK Freq0
÷ 1	0	0	0
÷ 1.5	0	0	1
÷ 2	0	1	0
÷ 3	0	1	1
÷ 4	1	0	0
Reserved	1	0	1
Reserved	1	1	x

**Table 10. MCLK Frequency**

## 6.6 Signal Selection - Address 06h

7	6	5	4	3	2	1	0
SDINSel	Reserved	Reserved	Reserved	Reserved	Reserved	LOOP	Reserved

### 6.6.1 DAC SDIN Source (Bit 7)

Function:

This bit is used to select the serial audio data source for the DAC as shown in [Table 11](#).

SDINSel Setting	DAC Data Source
0	SDIN1
1	SDIN2

**Table 11. DAC SDIN Source Selection**

### 6.6.2 Digital Loopback (Bit 1)

Function:

When this bit is set, an internal digital loopback from the ADC to the DAC will be enabled. Please refer to “[Internal Digital Loopback](#)” on page 28.

## 6.7 Channel B PGA Control - Address 07h

7	6	5	4	3	2	1	0
Reserved	Reserved	Gain5	Gain4	Gain3	Gain2	Gain1	Gain0

### 6.7.1 Channel B PGA Gain (Bits 5:0)

Function:

See “[Channel A PGA Gain \(Bits 5:0\)](#)” on page 39.

## 6.8 Channel A PGA Control - Address 08h

7	6	5	4	3	2	1	0
Reserved	Reserved	Gain5	Gain4	Gain3	Gain2	Gain1	Gain0

### 6.8.1 Channel A PGA Gain (Bits 5:0)

Function:

Sets the gain or attenuation for the ADC input PGA stage. The gain may be adjusted from -12 dB to +12 dB in 0.5 dB steps. The gain bits are in two’s complement with the Gain0 bit set for a 0.5 dB step. Register settings outside of the  $\pm 12$  dB range are reserved and must not be used. See [Table 12](#) for example settings.

Gain[5:0]	Setting
101000	-12 dB
000000	0 dB
011000	+12 dB

**Table 12. Example Gain and Attenuation Settings**

## 6.9 ADC Input Control - Address 09h

7	6	5	4	3	2	1	0
Reserved	Reserved	Reserved	PGASoft	PGAZero	Reserved	Reserved	Select

### 6.9.1 PGA Soft Ramp or Zero Cross Enable (Bits 4:3)

Function:

#### Soft Ramp Enable

Soft Ramp allows level changes, both muting and attenuation, to be implemented by incrementally ramping, in 1/8 dB steps, from the current level to the new level at a rate of 1 dB per 8 left/right clock periods. See [Table 13](#).

#### Zero Cross Enable

Zero Cross Enable dictates that signal-level changes, either by attenuation changes or muting, will occur on a signal zero crossing to minimize audible artifacts. The requested level change will occur after a time-out period between 512 and 1024 sample periods (10.7 ms to 21.3 ms at 48 kHz sample rate) if the signal does not encounter a zero crossing. The zero cross function is independently monitored and implemented for each channel. See [Table 13](#).

#### Soft Ramp and Zero Cross Enable

Soft Ramp and Zero Cross Enable dictate that signal-level changes, either by attenuation changes or muting, will occur in 1/8 dB steps and be implemented on a signal zero crossing. The 1/8 dB level change will occur after a time-out period between 512 and 1024 sample periods (10.7 ms to 21.3 ms at 48 kHz sample rate) if the signal does not encounter a zero crossing. The zero cross function is independently monitored and implemented for each channel. See [Table 13](#).

PGASoft	PGAZeroCross	Mode
0	0	Changes to affect immediately
0	1	Zero Cross enabled
1	0	Soft Ramp enabled
1	1	Soft Ramp and Zero Cross enabled (default)

**Table 13. PGA Soft Cross or Zero Cross Mode Selection**

### 6.9.2 Analog Input Selection (Bit 0)

Function:

These bits are used to select the input source for the PGA and ADC. Please see [Table 14](#).

Select	PGA/ADC Input
0	Microphone-Level Input
1	Line-Level Input

**Table 14. Analog Input Selection**

## 6.10 DAC Channel A Volume Control - Address 0Ah

See [6.11 DAC Channel B Volume Control - Address 0Bh](#).



## 6.11 DAC Channel B Volume Control - Address 0Bh

7	6	5	4	3	2	1	0
Vol7	Vol6	Vol5	Vol4	Vol3	Vol2	Vol1	Vol0

### 6.11.1 Volume Control (Bits 7:0)

Function:

The digital volume control allows the user to attenuate the signal in 0.5 dB increments from 0 to -127 dB. The Vol0 bit activates a 0.5 dB attenuation when set, and no attenuation when cleared. The Vol[7:1] bits activate attenuation equal to their decimal equivalent (in dB). Example volume settings are decoded as shown in [Table 15](#). The volume changes are implemented as dictated by the DACSoft and DACZero-Cross bits in the DAC Control 2 register (see [Section 6.12.1](#)).

Binary Code	Volume Setting
00000000	0 dB
00000001	-0.5 dB
00101000	-20 dB
00101001	-20.5 dB
11111110	-127 dB
11111111	-127.5 dB

**Table 15. Digital Volume Control Example Settings**

## 6.12 DAC Control 2 - Address 0Ch

7	6	5	4	3	2	1	0
DACSoft	DACZero	InvertDAC	Reserved	Reserved	Reserved	Reserved	Reserved

### 6.12.1 DAC Soft Ramp or Zero Cross Enable (Bits 7:6)

Function:

#### Soft Ramp Enable

Soft Ramp allows level changes, both muting and attenuation, to be implemented by incrementally ramping, in 1/8 dB steps, from the current level to the new level at a rate of 1 dB per 8 left/right clock periods. See [Table 16](#).

#### Zero Cross Enable

Zero Cross Enable dictates that signal-level changes, either by attenuation changes or muting, will occur on a signal zero crossing to minimize audible artifacts. The requested level change will occur after a time-out period between 512 and 1024 sample periods (10.7 ms to 21.3 ms at 48 kHz sample rate) if the signal does not encounter a zero crossing. The zero cross function is independently monitored and implemented for each channel. See [Table 16](#).

#### Soft Ramp and Zero Cross Enable

Soft Ramp and Zero Cross Enable dictate that signal-level changes, either by attenuation changes or muting, will occur in 1/8 dB steps and be implemented on a signal zero crossing. The 1/8 dB level change will occur after a time-out period between 512 and 1024 sample periods (10.7 ms to 21.3 ms at 48 kHz sam-

ple rate) if the signal does not encounter a zero crossing. The zero cross function is independently monitored and implemented for each channel. See [Table 16](#).

DACSoft	DACZeroCross	Mode
0	0	Changes to affect immediately
0	1	Zero Cross enabled
1	0	Soft Ramp enabled
1	1	Soft Ramp and Zero Cross enabled (default)

**Table 16. DAC Soft Cross or Zero Cross Mode Selection**

### 6.12.2 Invert DAC Output (Bit 5)

Function:

When this bit is set, the output of the DAC is inverted.

### 6.13 Status - Address 0Dh

7	6	5	4	3	2	1	0
Reserved	Reserved	Reserved	EFTC	ClkErr	Reserved	ADCOvfl	ADCUndrfl

For all bits in this register, a '1' means the associated condition has occurred at least once since the register was last read. A '0' means the associated condition has NOT occurred since the last reading of the register. Status bits that are masked off in the associated mask register will always be '0' in this register. This register defaults to 00h.

#### 6.13.1 E to F C-Buffer Transfer

Function:

Indicates the completion of an E to F C-buffer transfer. See [“Channel Status Buffer Management” on page 52](#) for more information.

#### 6.13.2 Clock Error (Bit 3)

Function:

Indicates the occurrence of a clock error condition.

#### 6.13.3 ADC Overflow (Bit 1)

Function:

Indicates the occurrence of an ADC overflow condition.

#### 6.13.4 ADC Underflow (Bit 0)

Function:

Indicates the occurrence of an ADC underflow condition.

### 6.14 Status Mask - Address 0Eh

7	6	5	4	3	2	1	0
Reserved	Reserved	Reserved	EFTCM	ClkErrM	Reserved	ADCOvf1M	ADCUndrflM

Function:

The bits of this register serve as a mask for the Status sources found in the register “[Status - Address 0Dh](#)” on page 42. If a mask bit is set to 1, the error is unmasked, meaning that its occurrence will affect the status register. If a mask bit is set to 0, the error is masked, meaning that its occurrence will not affect the status register. The bit positions align with the corresponding bits in the Status register.

### 6.15 Status Mode MSB - Address 0Fh

### 6.16 Status Mode LSB - Address 10h

7	6	5	4	3	2	1	0
Reserved	Reserved	Reserved	EFTC1	ClkErr1	Reserved	ADCOvf1	ADCUndrfl1
Reserved	Reserved	Reserved	EFTC0	ClkErr0	Reserved	ADCOvf0	ADCUndrfl0

Function:

The two Status Mode registers form a 2-bit code for each Status register function. There are three ways to update the Status register in accordance with the status condition. In the Rising-Edge Active Mode, the status bit becomes active on the arrival of the condition. In the Falling-Edge Active Mode, the status bit becomes active on the removal of the condition. In Level-Active Mode, the status bit is active during the condition.

- 00 - Rising edge active
- 01 - Falling edge active
- 10 - Level active
- 11 - Reserved

### 6.17 Transmitter Control 1 - Address 11h

7	6	5	4	3	2	1	0
Reserved	EFTCI	CAM	Reserved	Reserved	Reserved	Reserved	Reserved

#### 6.17.1 E to F C-Data Buffer Transfer Inhibit (Bit 6)

Function:

When cleared, C-data E to F buffer transfers are allowed. When set, C-data E to F buffer transfers are inhibited. See “[IEC60958-3 Channel Status \(C\) Bit Management](#)” on page 52.

#### 6.17.2 C-Data Access Mode (Bit 5)

Function:

When cleared, the C-data buffer will operate in One-byte control port access mode. When set, the C-data buffer will operate in Two-byte control port access mode. See “[IEC60958-3 Channel Status \(C\) Bit Management](#)” on page 52.

## 6.18 Transmitter Control 2 - Address 12h

7	6	5	4	3	2	1	0
Tx_DIF1	Tx_DIF0	TxOff	TxMute	V	MMT	MMTCS	MMTLR

### 6.18.1 Transmitter Digital Interface Format (Bits 7:6)

Function:

The required relationship between LRCK, SCLK and SDIN for the transmitter is defined by the Transmitter Digital Interface Format and the options are detailed in [Table 17](#) and [Figures 5-7](#).

Tx_DIF1	Tx_DIF0	Description	Format	Figure
0	0	Left Justified, up to 24-bit data (default)	0	<a href="#">5</a>
0	1	I <sup>2</sup> S, up to 24-bit data	1	<a href="#">6</a>
1	0	Right-Justified, 16-bit Data	2	<a href="#">7</a>
1	1	Right-Justified, 24-bit Data	3	<a href="#">7</a>

**Table 17. Transmitter Digital Interface Formats**

### 6.18.2 Transmitter Output Driver Control (Bit 5)

Function:

When this bit is cleared, the transmitter output pin driver will be in the normal operational mode. When set, the transmitter output pin driver will drive to a constant 0 V.

### 6.18.3 Transmitter Mute Control (Bit 4)

Function:

When this bit is cleared, the transmitter data will be in the normal operational mode. When set, the transmitter will output all zero data.

### 6.18.4 Transmitted Validity Bit Control (Bit 3)

Function:

This bit sets the transmitted Validity bit level.

When this bit is cleared, valid linear PCM audio data is indicated. When this bit is set, invalid or non-linear PCM audio data is indicated.

### 6.18.5 Transmitter Mono/Stereo Operation Control (Bit 2)

Function:

When this bit is cleared, the transmitter will operate in stereo mode. When set, the transmitter will operate in Mono Mode with one input channel's data output in both A and B subframes (see ["IEC60958-3 Channel Status \(C\) Bit Management"](#) on page 52) and the CS data defined by the MMTCS bit (see Section 6.18.6).

### 6.18.6 Mono Mode CS Data Source (Bit 1)

Function:

When this bit is cleared, the transmitter will transmit the channel A CS data in the A subframe and the channel B CS data in the B subframe.

When this bit is set, the transmitter will transmit the CS data defined for the channel selected by the MMTLR bit in both the A and B subframes.

### **6.18.7 Mono Mode Channel Selection (Bit 0)**

Function:

When this bit is cleared, channel A input data will be transmitted in both channel A and B subframes in mono mode. When this bit is set, channel B input data will be transmitted in both channel A and B subframes in Mono Mode.

## 7. PARAMETER DEFINITIONS

### Dynamic Range

The ratio of the rms value of the signal to the rms sum of all other spectral components over the specified bandwidth. Dynamic Range is a signal-to-noise ratio measurement over the specified bandwidth made with a -60 dBFS signal. 60 dB is added to resulting measurement to refer the measurement to full scale. This technique ensures that the distortion components are below the noise level and do not affect the measurement. This measurement technique has been accepted by the Audio Engineering Society, AES17-1991, and the Electronic Industries Association of Japan, EIAJ CP-307. Expressed in decibels.

### Total Harmonic Distortion + Noise

The ratio of the rms value of the signal to the rms sum of all other spectral components over the specified bandwidth (typically 10 Hz to 20 kHz), including distortion components. Expressed in decibels. Measured at -1 and -20 dBFS as suggested in AES17-1991 Annex A.

### Frequency Response

A measure of the amplitude response variation from 10 Hz to 20 kHz relative to the amplitude response at 1 kHz. Units in decibels.

### Interchannel Isolation

A measure of crosstalk between the left and right channels. Measured for each channel at the converter's output with no signal to the input under test and a full-scale signal applied to the other channel. Units in decibels.

### Interchannel Gain Mismatch

The gain difference between left and right channels. Units in decibels.

### Gain Drift

The change in gain value with temperature. Units in ppm/°C.

## 8. DAC FILTER PLOTS

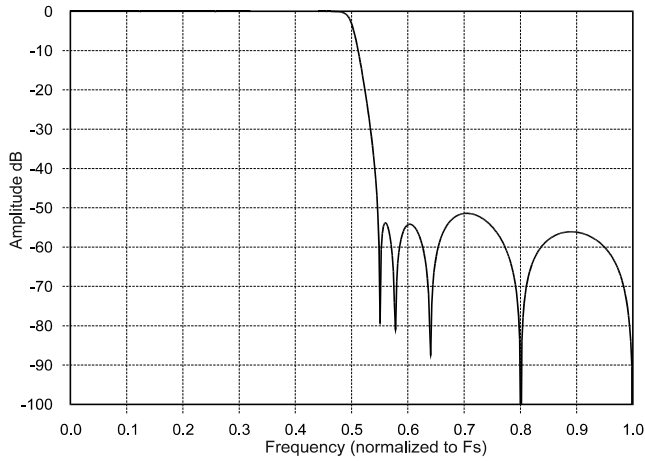

**Figure 18. DAC Single-Speed Stopband Rejection**

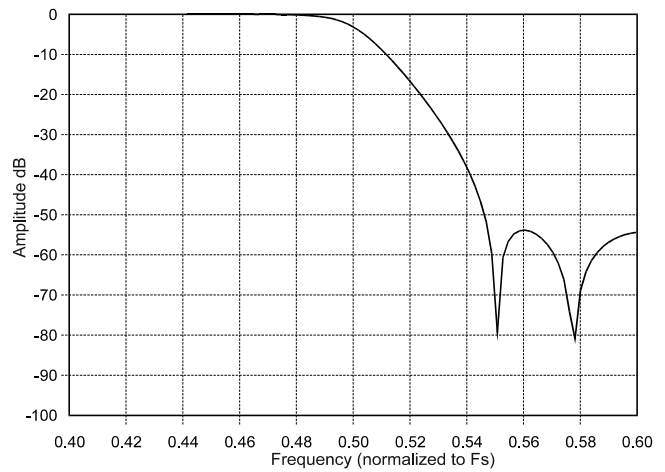

**Figure 19. DAC Single-Speed Transition Band**

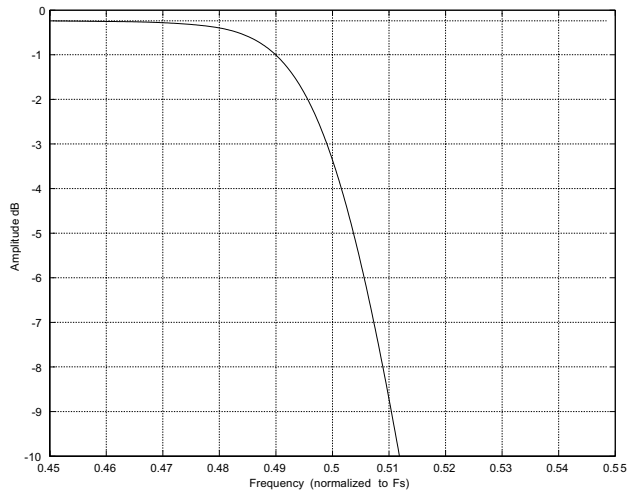

**Figure 20. DAC Single-Speed Transition Band**

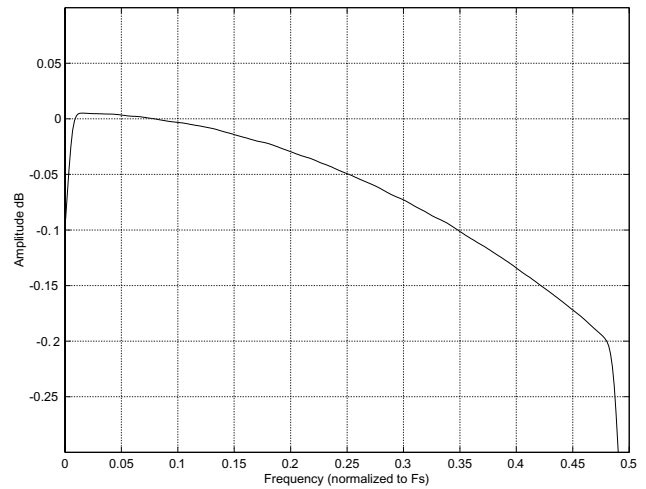

**Figure 21. DAC Single-Speed Passband Ripple**

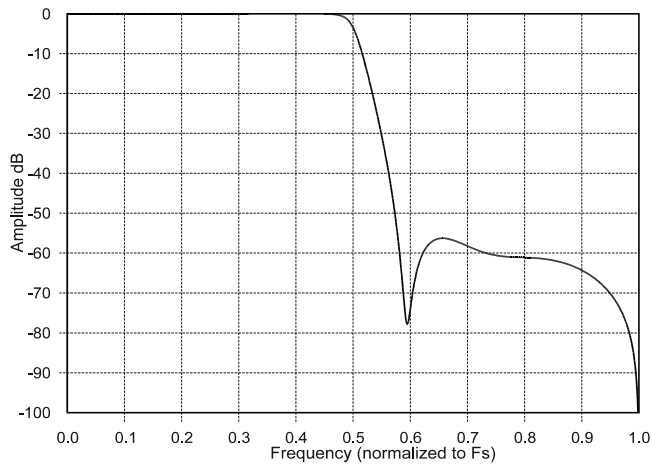

**Figure 22. DAC Double-Speed Stopband Rejection**

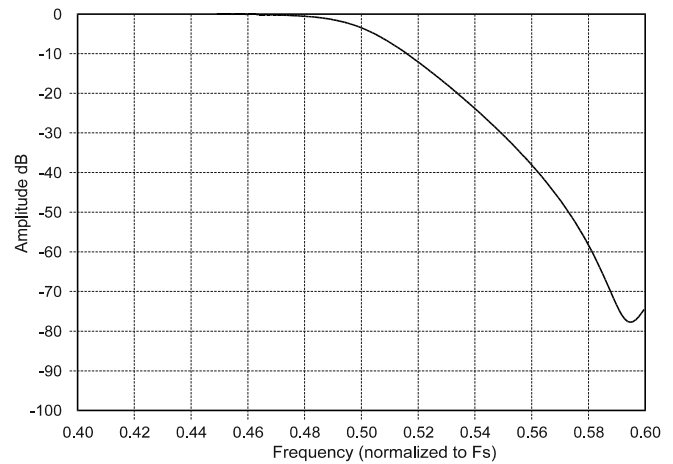

**Figure 23. DAC Double-Speed Transition Band**

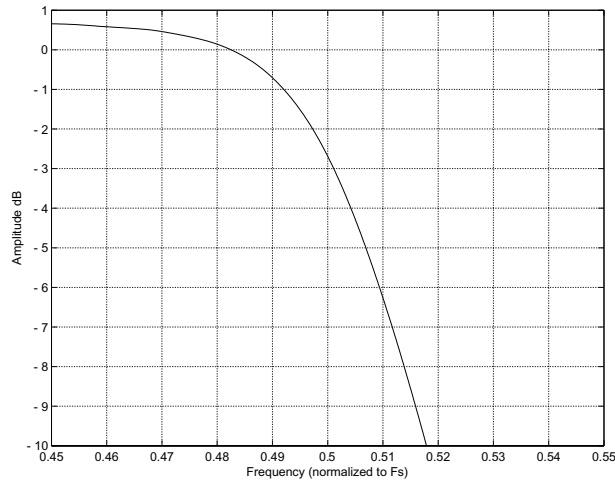
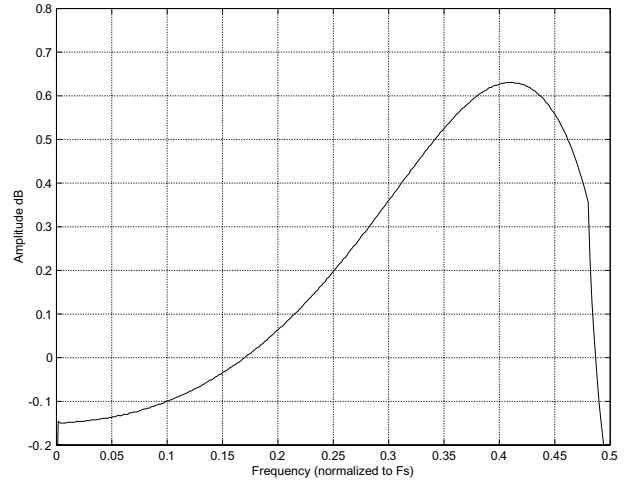
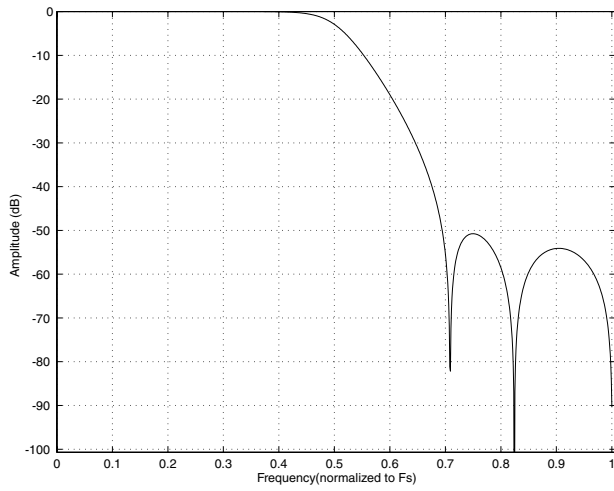
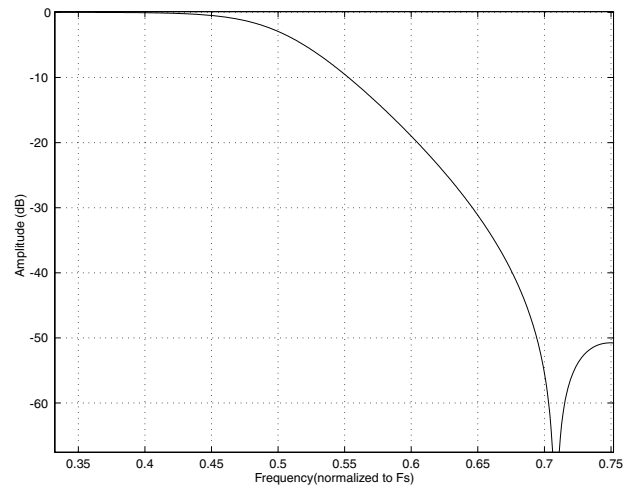
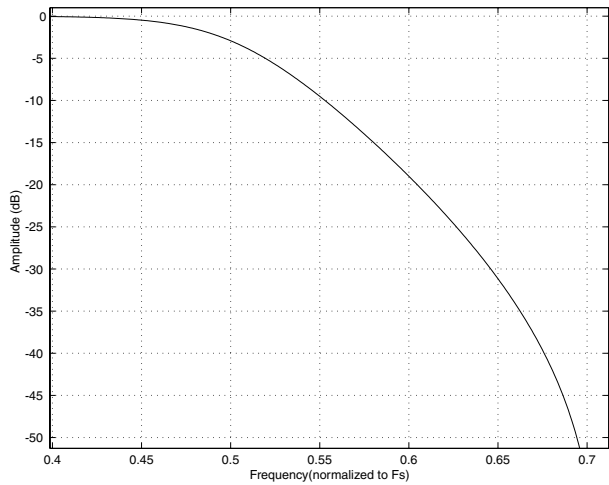
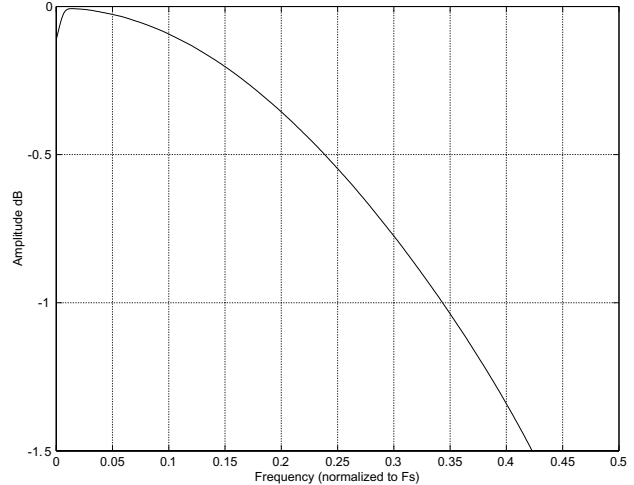
**Figure 24. DAC Double-Speed Transition Band**

**Figure 25. DAC Double-Speed Passband Ripple**

**Figure 26. DAC Quad-Speed Stopband Rejection**

**Figure 27. DAC Quad-Speed Transition Band**

**Figure 28. DAC Quad-Speed Transition Band**

**Figure 29. DAC Quad-Speed Passband Ripple**



## 9. ADC FILTER PLOTS

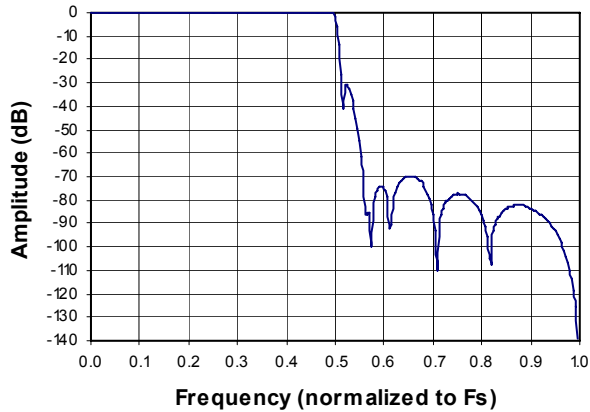

Figure 30. ADC Single-Speed Stopband Rejection

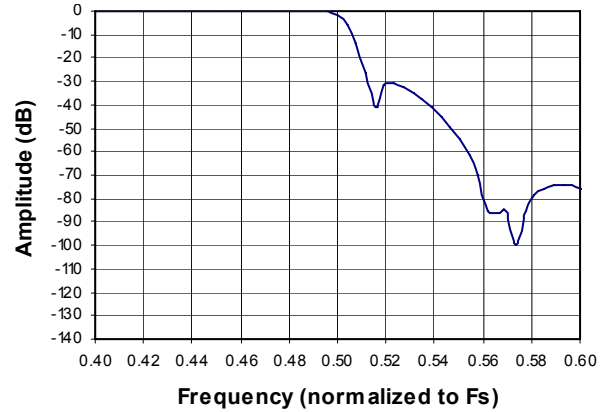

Figure 31. ADC Single-Speed Stopband Rejection

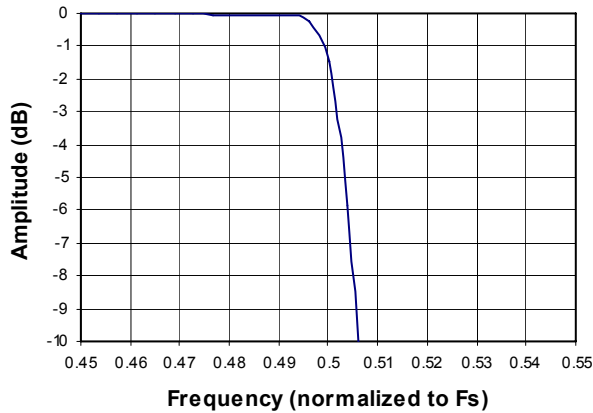

Figure 32. ADC Single-Speed Transition Band (Detail)

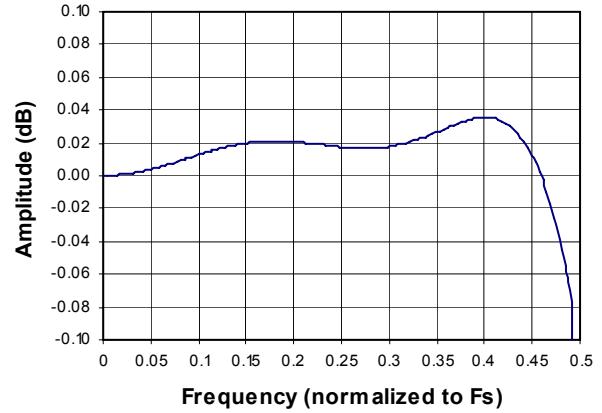

Figure 33. ADC Single-Speed Passband Ripple

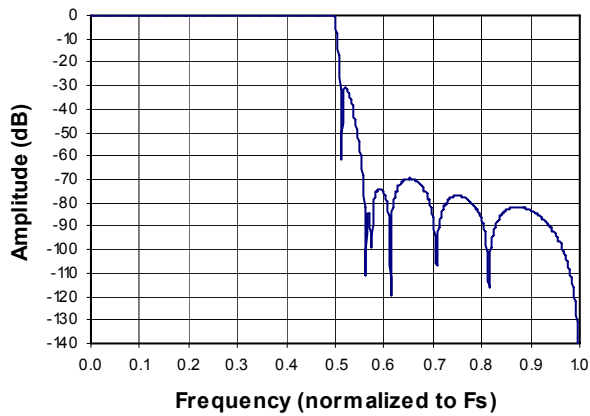

Figure 34. ADC Double-Speed Stopband Rejection

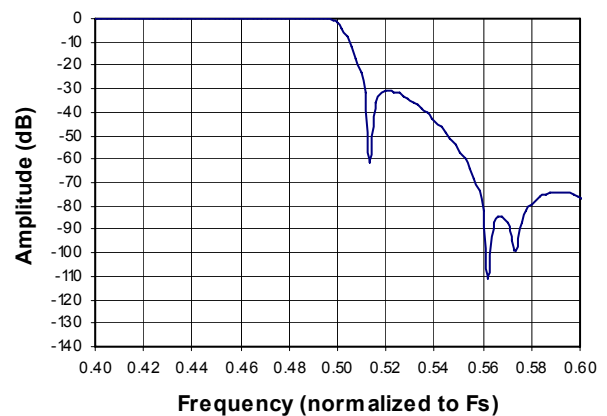
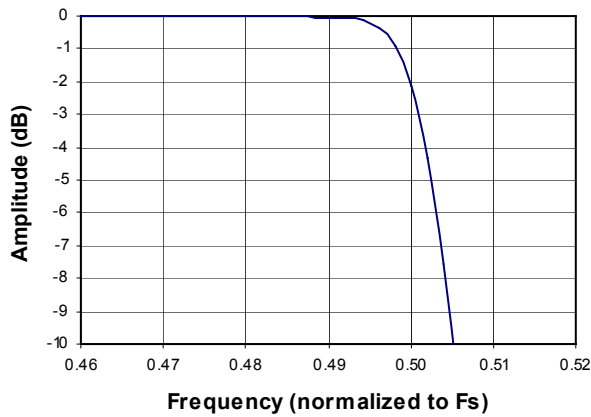
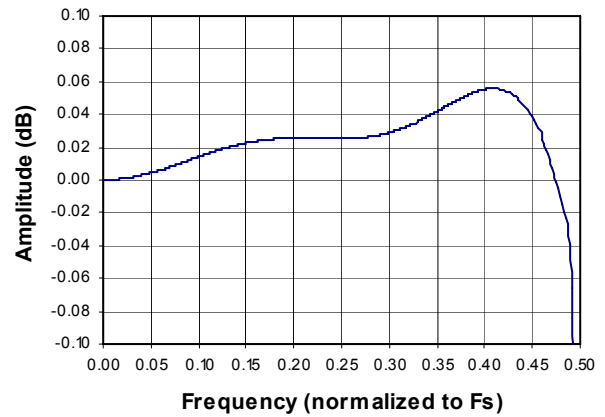
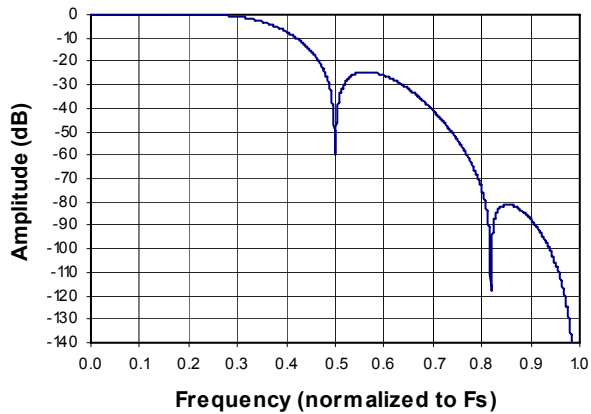
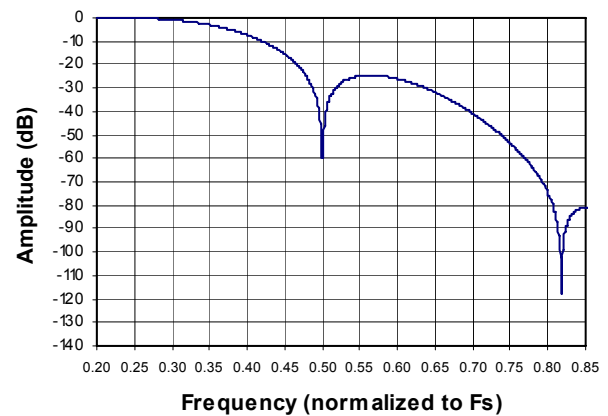
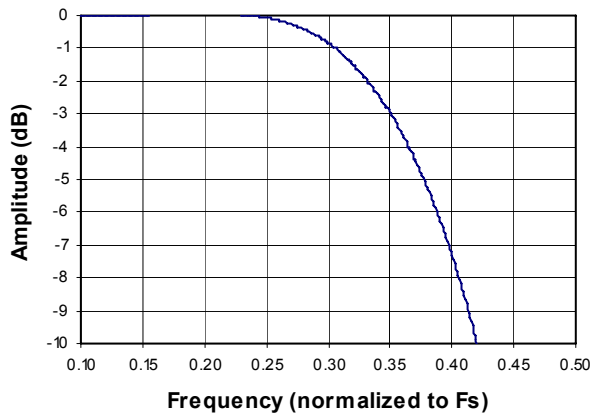
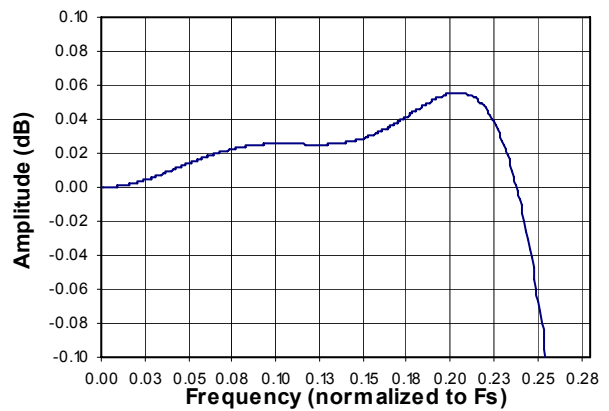

Figure 35. ADC Double-Speed Stopband Rejection

**Figure 36. ADC Double-Speed Transition Band (Detail)**

**Figure 37. ADC Double-Speed Passband Ripple**

**Figure 38. ADC Quad-Speed Stopband Rejection**

**Figure 39. ADC Quad-Speed Stopband Rejection**

**Figure 40. ADC Quad-Speed Transition Band (Detail)**

**Figure 41. ADC Quad-Speed Passband Ripple**

## 10.EXTERNAL IEC60958-3 TRANSMITTER COMPONENTS

This section details the external components required to interface the IEC60958-3 transmitter to cables and fiber-optic components.

### 10.1 IEC60958-3 Transmitter External Components

The IEC60958-3 specifications call for an unbalanced drive circuit with an output impedance of  $75 \Omega \pm 20\%$  and an output drive level of 0.5 volts peak-to-peak  $\pm 20\%$  when measured across a  $75 \Omega$  load using no cable. The circuit shown in [Figure 42](#) provides the proper output impedance and drive level using standard 1% resistors. If VD is driven from +3.3 V, use resistor values of  $243 \Omega$  in place of the  $374 \Omega$  resistor and a  $107 \Omega$  resistor in place of the  $90.9 \Omega$  resistor. The standard connector for a consumer application is an RCA phono socket.

The TXOUT pin may be used to drive TTL or CMOS gates as shown in [Figure 43](#). This circuit may be used for optical connectors for digital audio as they typically implement TTL or CMOS compatible inputs. This circuit is also useful when driving multiple digital audio outputs as RS422 line drivers typically implement TTL compatible inputs.

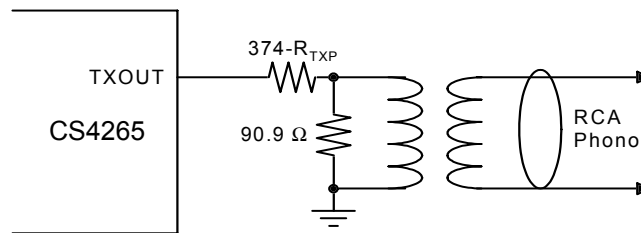

**Figure 42. Consumer Output Circuit (VD = 5 V)**

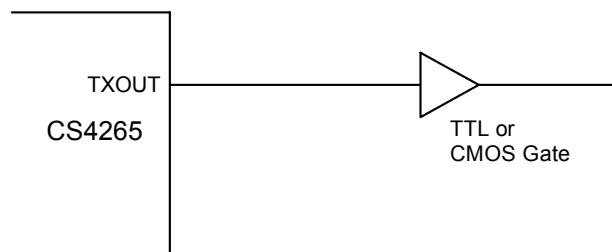

**Figure 43. TTL/CMOS Output Circuit**

### 10.2 Isolating Transformer Requirements

Please refer to Cirrus application note AN134: *AES and SPDIF Recommended Transformers* for resources on transformer selection.

## 11.CHANNEL STATUS BUFFER MANAGEMENT

The CS4265 has a comprehensive channel status (C) data buffering scheme which allows the user to manage the C data through the control port.

### 11.1 IEC60958-3 Channel Status (C) Bit Management

The CS4265 contains sufficient RAM to store a full block of C data for both A and B channels ( $192 \times 2 = 384$  bits). The user may read from, or write to, these RAM buffers through the control port.

The CS4265 manages the flow of channel status data at the block level, meaning that entire blocks of channel status information are buffered at the input, synchronized to the output time base, and then transmitted. The buffering scheme involves a cascade of two block-sized buffers, named E and F, as shown in [Figure 44](#). The MSB of each byte represents the first bit in the serial C data stream. For example, the MSB of byte 0 (which is at control port address 13h) is the consumer/professional bit for channel status block A.

The E buffer is accessible from the control port, allowing read and writing of the C data. The F buffer is used as the source of C data for the IEC60958-3 transmitter. The F buffer accepts block transfers from the E buffer.

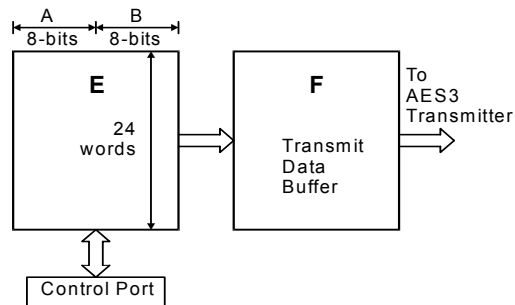

**Figure 44. Channel Status Data Buffer Structure**

### 11.1.1 Accessing the E Buffer

The user can monitor the data being transferred by reading the E buffer, which is mapped into the register space of the CS4265, through the control port. The user can modify the data to be transmitted by writing to the E buffer.

The E buffer is only accessible when an MCLK signal is applied to the CS4265 and the device is out of the power-down state (the PDN bit in register 02h is cleared). If either of these conditions is not met, the values stored in the E buffer will not change when written via the control port.

The user can configure the status register such that EFTC bit is set whenever an E to F transfer completes. With this configuration in place, periodic polling of the status register allows determination of the time periods acceptable for E buffer interaction.

Also provided is an “E to F” inhibit bit. The “E to F” buffer transfer is disabled whenever the user sets this bit. This may be used whenever “long” control port interactions are occurring.

A flowchart for reading and writing to the E buffer is shown in [Figure 45](#). For writing, the sequence starts after an E to F transfer, which is based on the output timebase.

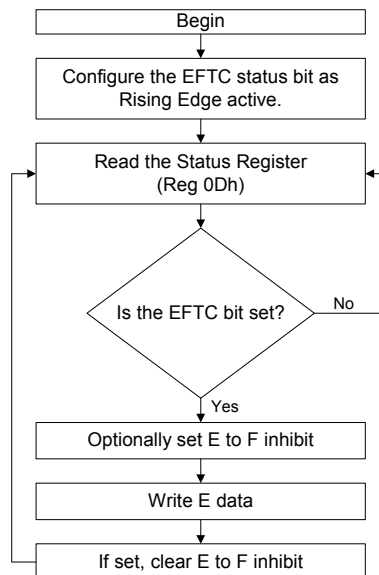

**Figure 45. Flowchart for Writing the E Buffer**

## 11.2 Serial Copy Management System (SCMS)

The CS4265 allows read/modify/write access to all the channel status bits. For consumer mode SCMS compliance, the host microcontroller needs to manipulate the Category Code, Copy bit and L bit appropriately.

## 11.3 Channel Status Data E Buffer Access

The E buffer is organized as 24 x 16-bit words. For each word, the most significant byte is the A channel data, and the least significant byte is the B channel data (see [Figure 44](#)).

There are two methods of accessing this memory, known as One-Byte Mode and Two-Byte Mode. The desired mode is selected through a control register bit.

### 11.3.1 *One-Byte Mode*

In many applications, the channel status blocks for the A and B channels will be identical. In this situation, if the user reads a byte from one of the channel's blocks, the corresponding byte for the other channel will be the same. Similarly, if the user wrote a byte to one channel's block, it would be necessary to write the same byte to the other block. One-Byte Mode takes advantage of the often identical nature of A and B channel status data.

When reading data in One-Byte Mode, a single byte is returned, which can be from channel A or B data, depending on a register control bit. If a write is being done, the CS4265 expects a single byte to be input to its control port. This byte will be written to both the A and B locations in the addressed word.

One-Byte Mode saves the user substantial control port access time, as it effectively accesses two byte's worth of information in 1 byte's worth of access time. If the control port's auto increment addressing is used in combination with this mode, multi-byte accesses such as full-block reads or writes can be done especially efficiently.

### 11.3.2 *Two-Byte Mode*

There are those applications in which the A and B channel status blocks will not be the same, and the user is interested in accessing both blocks. In these situations, Two-Byte Mode should be used to access the E buffer.

In this mode, a read will cause the CS4265 to output two bytes from its control port. The first byte out represents the A channel status data, and the second byte represents the B channel status data. Writing is similar, in that two bytes must now be input to the CS4265's control port. The A channel status data is first; B channel status data is second.

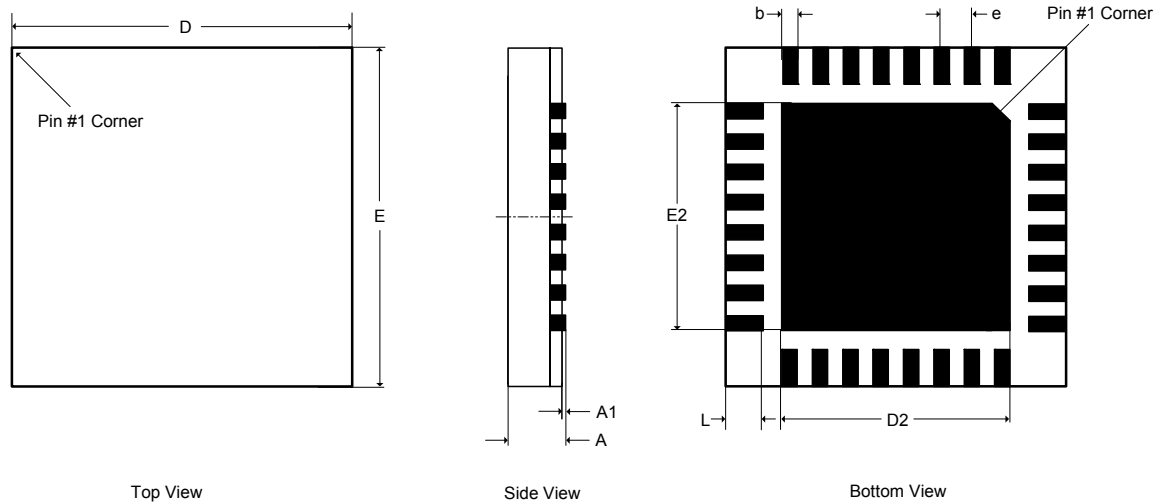
**12.PACKAGE DIMENSIONS**
**32L QFN (5 X 5 mm BODY) PACKAGE DRAWING**

DIM	INCHES			MILLIMETERS			NOTE
	MIN	NOM	MAX	MIN	NOM	MAX	
A	--	--	0.0394	--	--	1.00	1
A1	0.0000	--	0.0020	0.00	--	0.05	1
b	0.0071	0.0091	0.0110	0.18	0.23	0.28	1,2
D	0.1969 BSC			5.00 BSC			1
D2	0.1280	0.1299	0.1319	3.25	3.30	3.35	1
E	0.1969 BSC			5.00 BSC			1
E2	0.1280	0.1299	0.1319	3.25	3.30	3.35	1
e	0.0197 BSC			0.50 BSC			1
L	0.0118	0.0157	0.0197	0.30	0.40	0.50	1

**JEDEC #: MO-220**

*Controlling Dimension is Millimeters.*

**Notes:**

1. Dimensioning and tolerance per ASME Y 14.5M-1995.
2. Dimensioning lead width applies to the plated terminal and is measured between 0.20 mm and 0.25 mm from the terminal tip.

**13.THERMAL CHARACTERISTICS AND SPECIFICATIONS**

Parameters	Symbol	Min	Typ	Max	Units
Package Thermal Resistance	$\theta_{JA}$	-	52	-	°C/Watt
		-	38	-	°C/Watt
Allowable Junction Temperature		-	-	125	°C

## 14. ORDERING INFORMATION

Product	Description	Package	Pb-Free	Grade	Temp Range	Container	Order #
CS4265	24-bit, 192 kHz Stereo Audio CODEC	32-QFN	Yes	Commercial	-10° to +70° C	Tube	CS4265-CNZ
						Tape & Reel	CS4265-CNZR
CS4265	24-bit, 192 kHz Stereo Audio CODEC	32-QFN	Yes	Automotive	-40° to +105° C	Tube	CS4265-DNZ
						Tape & Reel	CS4265-DNZR
CDB4265	CS4265 Evaluation Board		No	-	-	-	CDB4265

## 15. REVISION HISTORY

Release	Changes
F1	<ul style="list-style-type: none"> <li>- Removed the MAP auto-increment functional description from the <a href="#">I<sup>2</sup>C Control Port Description and Timing</a> section beginning on <a href="#">page 30</a>.</li> <li>- Added device revision information to the <a href="#">Chip ID - Register 01h</a> description on <a href="#">page 35</a>.</li> <li>- Updated the VQ Output Impedance specification in the <a href="#">DC Electrical Characteristics</a> table on <a href="#">page 17</a>.</li> <li>- Updated the Microphone Interchannel Isolation specification in the <a href="#">ADC Analog Characteristics</a> table on <a href="#">page 15</a>.</li> </ul>
F2	<ul style="list-style-type: none"> <li>- Added Automotive Grade</li> <li>- Updated the <a href="#">DAC Analog Characteristics</a> table on <a href="#">page 10</a>.</li> <li>- Updated the <a href="#">ADC Analog Characteristics</a> table on <a href="#">page 13</a>.</li> <li>- Updated the <a href="#">DC Electrical Characteristics</a> table on <a href="#">page 17</a>.</li> <li>- Updated the <a href="#">Digital Interface Characteristics</a> table on <a href="#">page 18</a>.</li> <li>- Updated the <a href="#">Switching Characteristics - Serial Audio Port</a> table on <a href="#">page 19</a>.</li> <li>- Updated the <a href="#">Typical Connection Diagram</a> on <a href="#">page 23</a>.</li> <li>- Switched <a href="#">Channel B PGA Control - Address 07h</a> on <a href="#">page 39</a> and <a href="#">Channel A PGA Control - Address 08h</a> on <a href="#">page 39</a>.</li> </ul>

## Contacting Cirrus Logic Support

For all product questions and inquiries, contact a Cirrus Logic Sales Representative.  
To find the one nearest you, go to [www.cirrus.com](http://www.cirrus.com)

### IMPORTANT NOTICE

Cirrus Logic, Inc. and its subsidiaries ("Cirrus") believe that the information contained in this document is accurate and reliable. However, the information is subject to change without notice and is provided "AS IS" without warranty of any kind (express or implied). Customers are advised to obtain the latest version of relevant information to verify, before placing orders, that information being relied on is current and complete. All products are sold subject to the terms and conditions of sale supplied at the time of order acknowledgment, including those pertaining to warranty, indemnification, and limitation of liability. No responsibility is assumed by Cirrus for the use of this information, including use of this information as the basis for manufacture or sale of any items, or for infringement of patents or other rights of third parties. This document is the property of Cirrus and by furnishing this information, Cirrus grants no license, express or implied under any patents, mask work rights, copyrights, trademarks, trade secrets or other intellectual property rights. Cirrus owns the copyrights associated with the information contained herein and gives consent for copies to be made of the information only for use within your organization with respect to Cirrus integrated circuits or other products of Cirrus. This consent does not extend to other copying such as copying for general distribution, advertising or promotional purposes, or for creating any work for resale.

CERTAIN APPLICATIONS USING SEMICONDUCTOR PRODUCTS MAY INVOLVE POTENTIAL RISKS OF DEATH, PERSONAL INJURY, OR SEVERE PROPERTY OR ENVIRONMENTAL DAMAGE ("CRITICAL APPLICATIONS"). CIRRUS PRODUCTS ARE NOT DESIGNED, AUTHORIZED OR WARRANTED FOR USE IN AIRCRAFT SYSTEMS, MILITARY APPLICATIONS, PRODUCTS SURGICALLY IMPLANTED INTO THE BODY, AUTOMOTIVE SAFETY OR SECURITY DEVICES, LIFE SUPPORT PRODUCTS OR OTHER CRITICAL APPLICATIONS. INCLUSION OF CIRRUS PRODUCTS IN SUCH APPLICATIONS IS UNDERSTOOD TO BE FULLY AT THE CUSTOMER'S RISK AND CIRRUS DISCLAIMS AND MAKES NO WARRANTY, EXPRESS, STATUTORY OR IMPLIED, INCLUDING THE IMPLIED WARRANTIES OF MERCHANTABILITY AND FITNESS FOR PARTICULAR PURPOSE, WITH REGARD TO ANY CIRRUS PRODUCT THAT IS USED IN SUCH A MANNER. IF THE CUSTOMER OR CUSTOMER'S CUSTOMER USES OR PERMITS THE USE OF CIRRUS PRODUCTS IN CRITICAL APPLICATIONS, CUSTOMER AGREES, BY SUCH USE, TO FULLY INDEMNIFY CIRRUS, ITS OFFICERS, DIRECTORS, EMPLOYEES, DISTRIBUTORS AND OTHER AGENTS FROM ANY AND ALL LIABILITY, INCLUDING ATTORNEYS' FEES AND COSTS, THAT MAY RESULT FROM OR ARISE IN CONNECTION WITH THESE USES.

Cirrus Logic, Cirrus, the Cirrus Logic logo designs, and Popguard are trademarks of Cirrus Logic, Inc. All other brand and product names in this document may be trademarks or service marks of their respective owners.

I<sup>2</sup>C is a registered trademark of Philips Semiconductor.