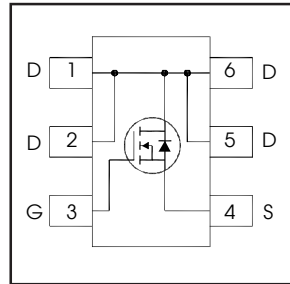


# IRLTS6342PbF

HEXFET® Power MOSFET

$V_{DS}$	<b>30</b>	<b>V</b>
$V_{GS}$	<b>±12</b>	<b>V</b>
$R_{DS(on) \max}$ (@ $V_{GS} = 4.5V$ )	<b>17.5</b>	<b>mΩ</b>
$R_{DS(on) \max}$ (@ $V_{GS} = 2.5V$ )	<b>22.0</b>	<b>mΩ</b>
$Q_g$ (typical)	<b>11</b>	<b>nC</b>
$I_D$ (@ $T_A = 25^\circ C$ )	<b>8.3</b>	<b>A</b>



## Applications

- System/Load Switch

## Features and Benefits

### Features

Industry-Standard TSOP-6 Package
RoHS Compliant Containing no Lead, no Bromide and no Halogen
MSL1, Consumer Qualification



### Resulting Benefits

Multi-Vendor Compatibility
Environmentally Friendlier
Increased Reliability

Orderable part number	Package Type	Standard Pack		Note
		Form	Quantity	
IRLTS6342TRPBF	TSOP-6	Tape and Reel	3000	

## Absolute Maximum Ratings

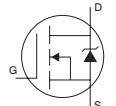
	Parameter	Max.	Units
$V_{DS}$	Drain-to-Source Voltage	30	V
$V_{GS}$	Gate-to-Source Voltage	±12	
$I_D @ T_A = 25^\circ C$	Continuous Drain Current, $V_{GS} @ 4.5V$	8.3	A
$I_D @ T_A = 70^\circ C$	Continuous Drain Current, $V_{GS} @ 4.5V$	6.7	
$I_{DM}$	Pulsed Drain Current ①	64	
$P_D @ T_A = 25^\circ C$	Power Dissipation ③	2.0	W
$P_D @ T_A = 70^\circ C$	Power Dissipation ③	1.3	
	Linear Derating Factor	0.02	W/°C
$T_J$	Operating Junction and	-55 to + 150	°C
$T_{STG}$	Storage Temperature Range		

Notes ① through ④ are on page 2

### Static @ T<sub>J</sub> = 25°C (unless otherwise specified)

	Parameter	Min.	Typ.	Max.	Units	Conditions
BV <sub>DSS</sub>	Drain-to-Source Breakdown Voltage	30	—	—	V	V <sub>GS</sub> = 0V, I <sub>D</sub> = 250μA
ΔBV <sub>DSS</sub> /ΔT <sub>J</sub>	Breakdown Voltage Temp. Coefficient	—	23	—	mV/°C	Reference to 25°C, I <sub>D</sub> = 1mA
R <sub>DS(on)</sub>	Static Drain-to-Source On-Resistance	—	14.0	17.5	mΩ	V <sub>GS</sub> = 4.5V, I <sub>D</sub> = 8.3A ②
		—	17.5	22.0		V <sub>GS</sub> = 2.5V, I <sub>D</sub> = 6.7A ②
V <sub>GS(th)</sub>	Gate Threshold Voltage	0.5	—	1.1	V	V <sub>DS</sub> = V <sub>GS</sub> , I <sub>D</sub> = 10μA
ΔV <sub>GS(th)</sub>	Gate Threshold Voltage Coefficient	—	-4.3	—	mV/°C	
I <sub>DSS</sub>	Drain-to-Source Leakage Current	—	—	1.0	μA	V <sub>DS</sub> = 24V, V <sub>GS</sub> = 0V
		—	—	150		V <sub>DS</sub> = 24V, V <sub>GS</sub> = 0V, T <sub>J</sub> = 125°C
I <sub>GSS</sub>	Gate-to-Source Forward Leakage	—	—	100	nA	V <sub>GS</sub> = 12V
	Gate-to-Source Reverse Leakage	—	—	-100		V <sub>GS</sub> = -12V
g <sub>fs</sub>	Forward Transconductance	25	—	—	S	V <sub>DS</sub> = 10V, I <sub>D</sub> = 6.4A
Q <sub>g</sub>	Total Gate Charge	—	11	—	nC	V <sub>GS</sub> = 4.5V
Q <sub>gs</sub>	Gate-to-Source Charge	—	0.5	—		V <sub>DS</sub> = 15V
Q <sub>gd</sub>	Gate-to-Drain Charge	—	4.6	—		I <sub>D</sub> = 6.4A
R <sub>G</sub>	Gate Resistance	—	2.2	—	Ω	
t <sub>d(on)</sub>	Turn-On Delay Time	—	5.4	—	ns	V <sub>DD</sub> = 15V, V <sub>GS</sub> = 4.5V ③
t <sub>r</sub>	Rise Time	—	11	—		I <sub>D</sub> = 6.4A
t <sub>d(off)</sub>	Turn-Off Delay Time	—	32	—		R <sub>G</sub> = 6.8Ω
t <sub>f</sub>	Fall Time	—	15	—		See Figs. 18
C <sub>iss</sub>	Input Capacitance	—	1010	—	pF	V <sub>GS</sub> = 0V
C <sub>oss</sub>	Output Capacitance	—	96	—		V <sub>DS</sub> = 25V
C <sub>rss</sub>	Reverse Transfer Capacitance	—	70	—		f = 1.0MHz

### Diode Characteristics

	Parameter	Min.	Typ.	Max.	Units	Conditions
I <sub>S</sub>	Continuous Source Current (Body Diode)	—	—	2.0	A	MOSFET symbol showing the integral reverse p-n junction diode. 
I <sub>SM</sub>	Pulsed Source Current (Body Diode) ①	—	—	64		
V <sub>SD</sub>	Diode Forward Voltage	—	—	1.2	V	T <sub>J</sub> = 25°C, I <sub>S</sub> = 8.3A, V <sub>GS</sub> = 0V ②
t <sub>rr</sub>	Reverse Recovery Time	—	13	20	ns	T <sub>J</sub> = 25°C, I <sub>F</sub> = 6.4A, V <sub>DD</sub> = 24V
Q <sub>rr</sub>	Reverse Recovery Charge	—	5.8	8.7	nC	di/dt = 100/μs ②

### Thermal Resistance

	Parameter	Typ.	Max.	Units
R <sub>θJA</sub>	Junction-to-Ambient ③	—	62.5	°C/W

#### Notes:

- ① Repetitive rating; pulse width limited by max. junction temperature.
- ② Pulse width ≤ 400μs; duty cycle ≤ 2%.
- ③ When mounted on 1 inch square copper board.
- ④ R<sub>θ</sub> is measured at T<sub>J</sub> of approximately 90°C.

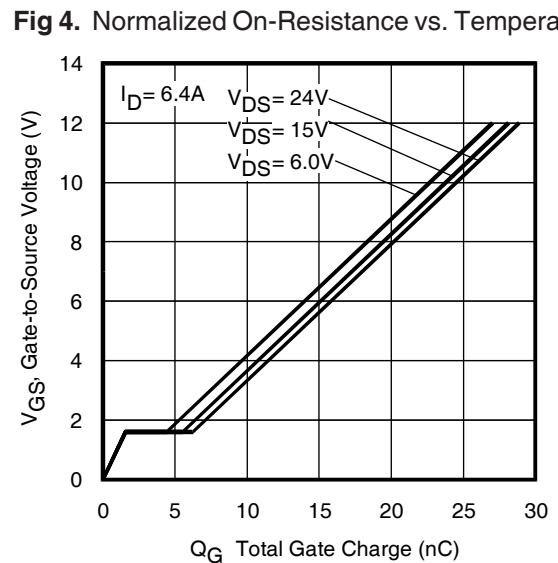
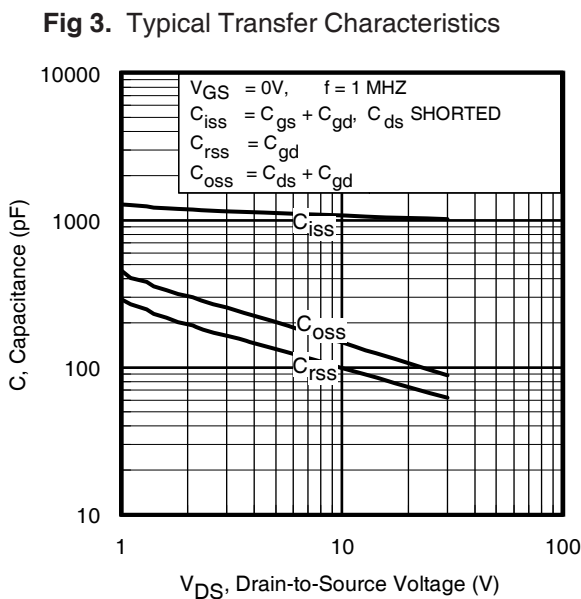
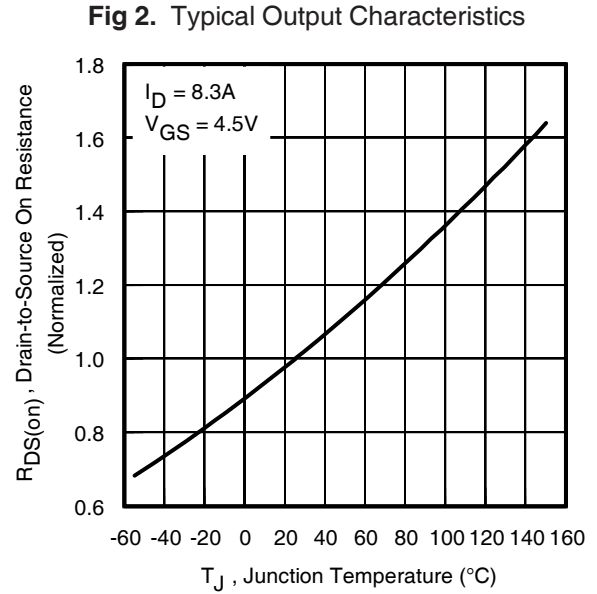
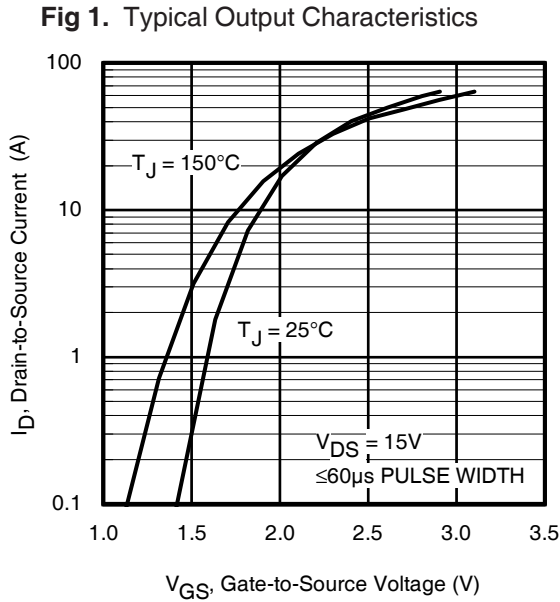
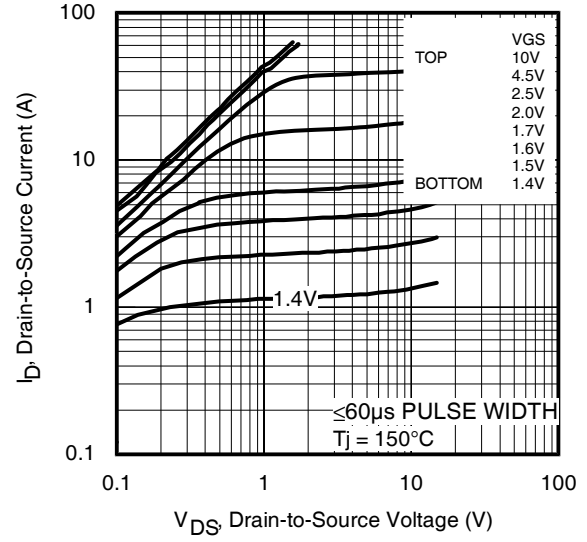
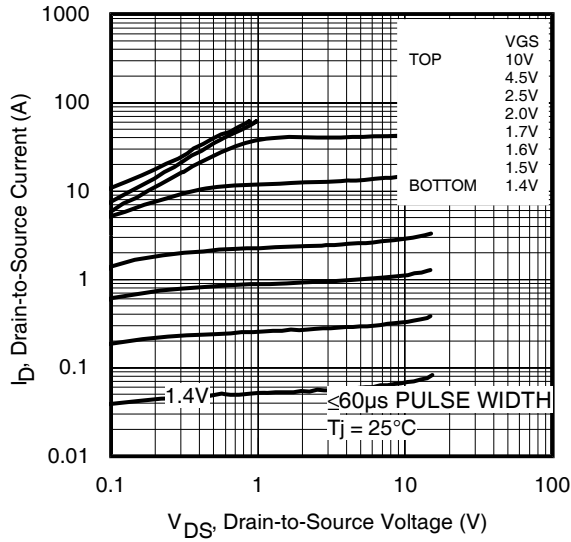
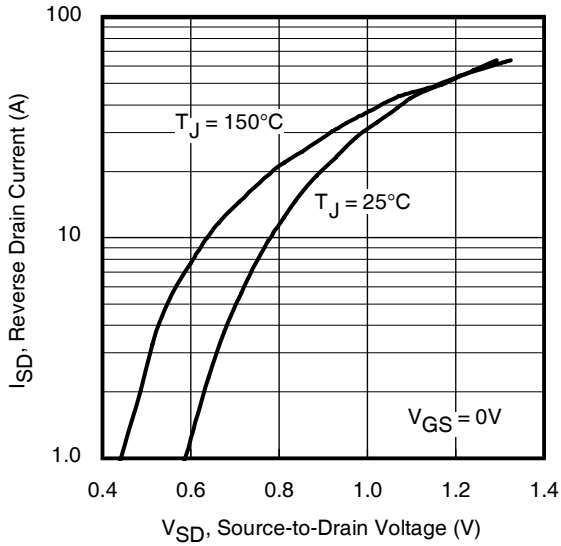
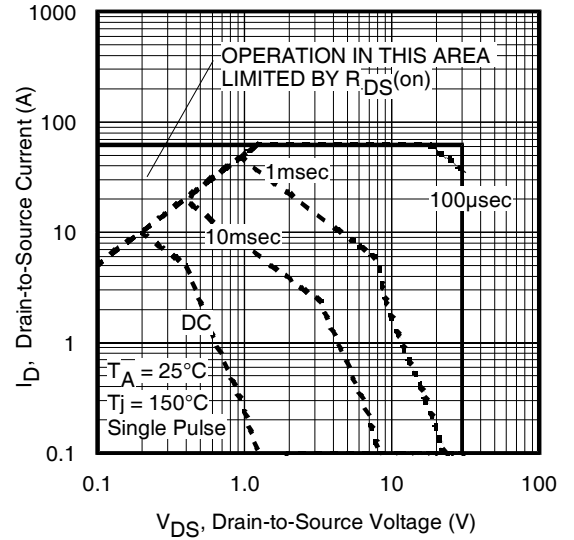


Fig 5. Typical Capacitance vs. Drain-to-Source Voltage  
www.irf.com

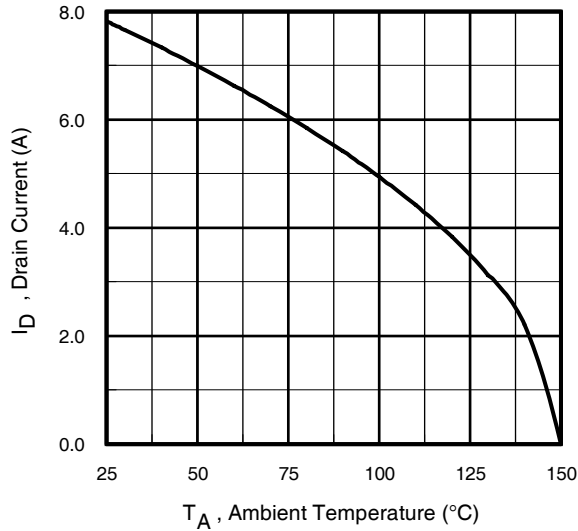
Fig 6. Typical Gate Charge vs. Gate-to-Source Voltage



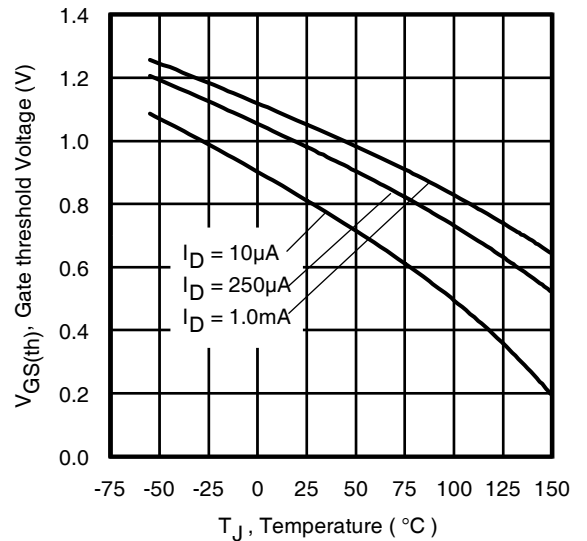
**Fig 7.** Typical Source-Drain Diode Forward Voltage



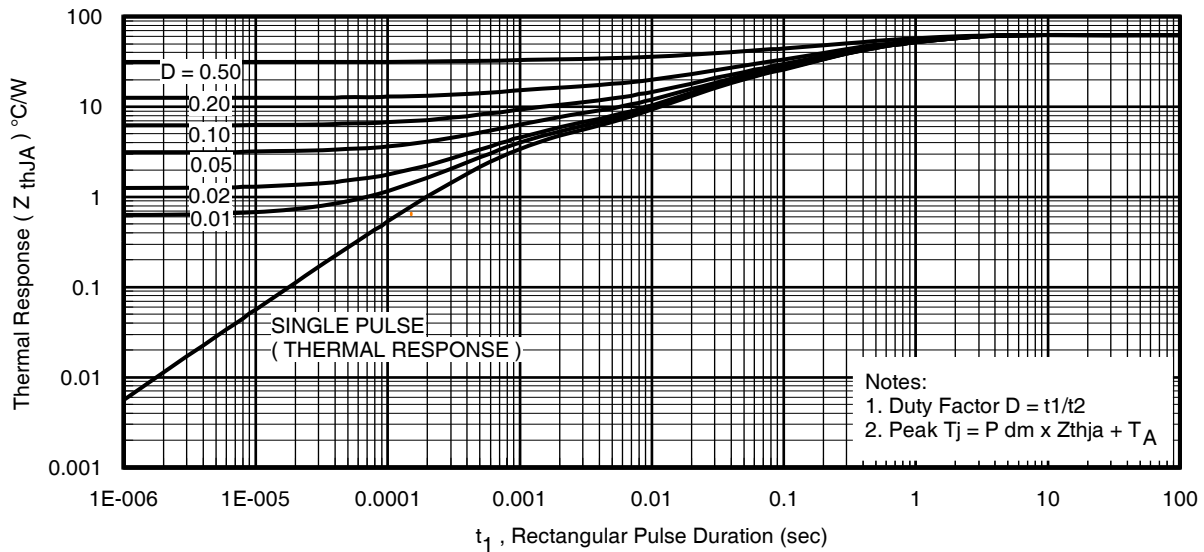
**Fig 8.** Maximum Safe Operating Area



**Fig 9.** Maximum Drain Current vs. Ambient Temperature



**Fig 10.** Threshold Voltage vs. Temperature



**Fig 11.** Maximum Effective Transient Thermal Impedance, Junction-to-Ambient

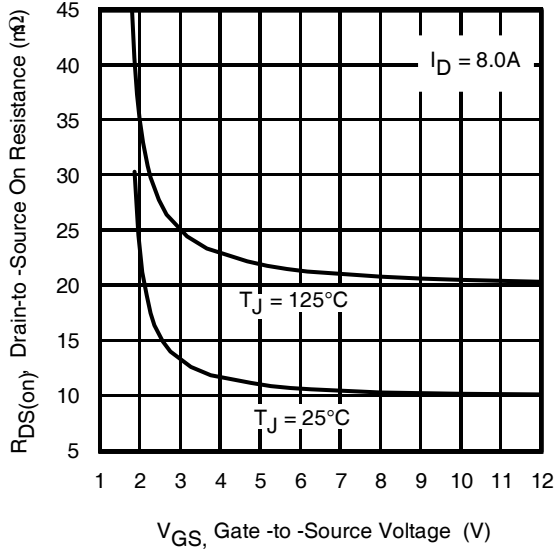


Fig 12. On-Resistance vs. Gate Voltage

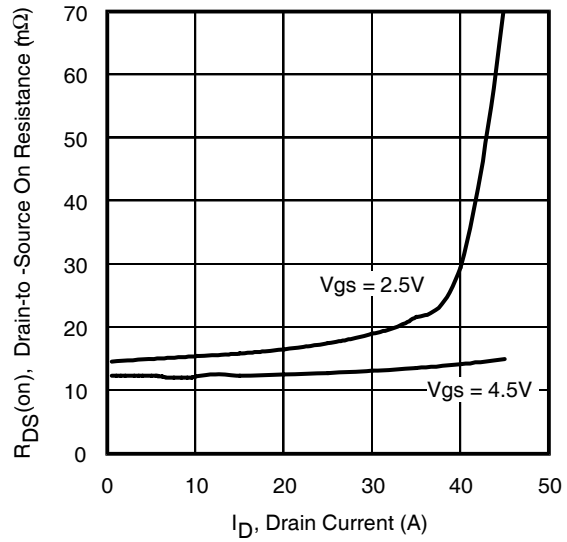


Fig 13. Typical On-Resistance vs. Drain Current

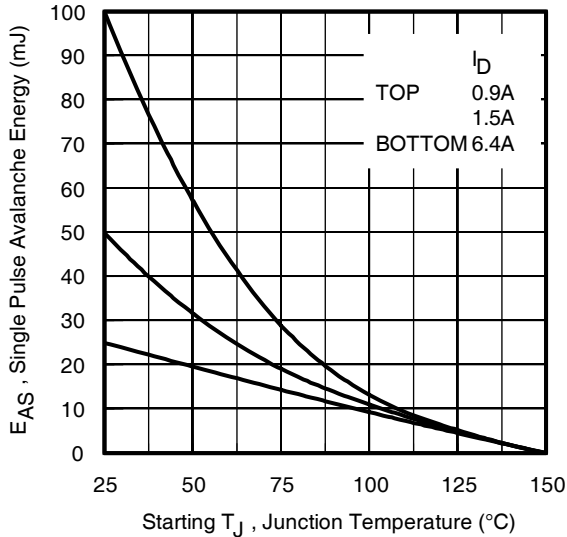


Fig 14. Maximum Avalanche Energy vs. Drain Current

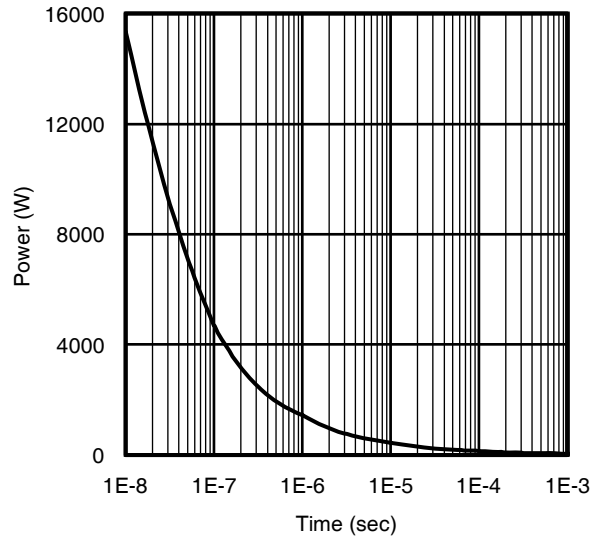


Fig 15. Typical Power vs. Time

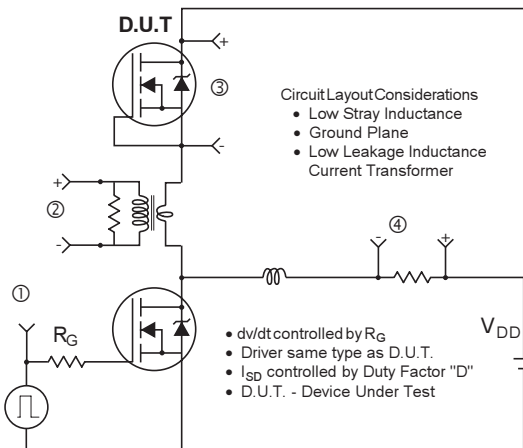
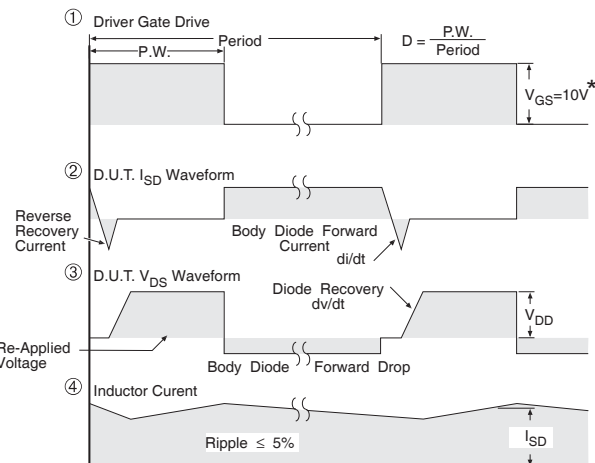
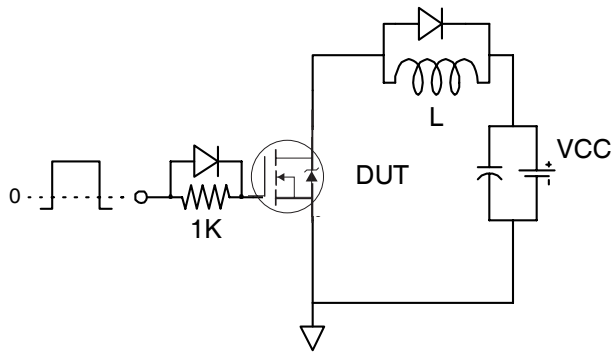


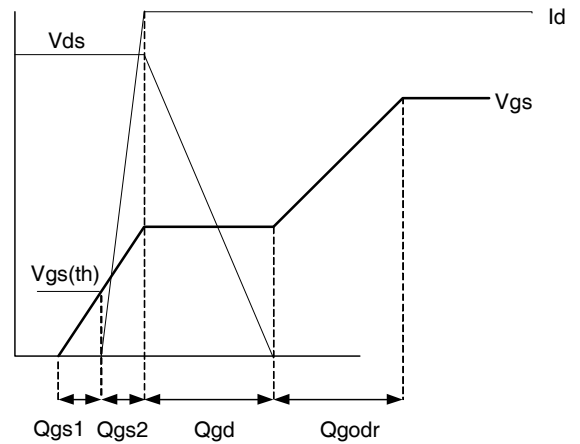
Fig 16. Peak Diode Recovery dv/dt Test Circuit for N-Channel HEXFET® Power MOSFETs



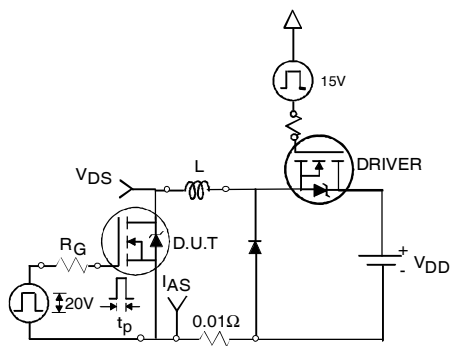
\*  $V_{GS} = 5V$  for Logic Level Devices



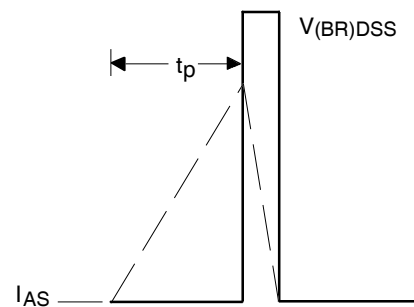
**Fig 17a.** Gate Charge Test Circuit



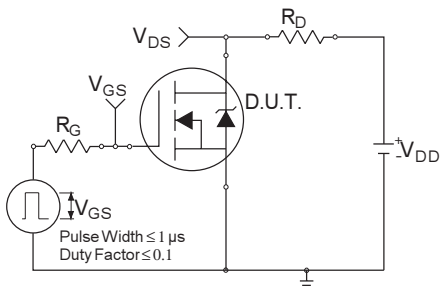
**Fig 17b.** Gate Charge Waveform



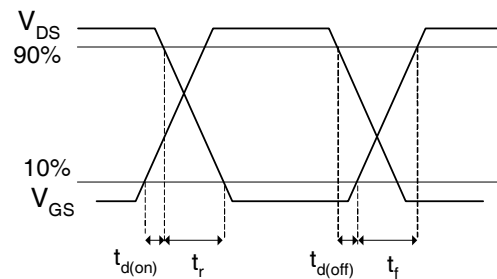
**Fig 18a.** Unclamped Inductive Test Circuit



**Fig 18b.** Unclamped Inductive Waveforms

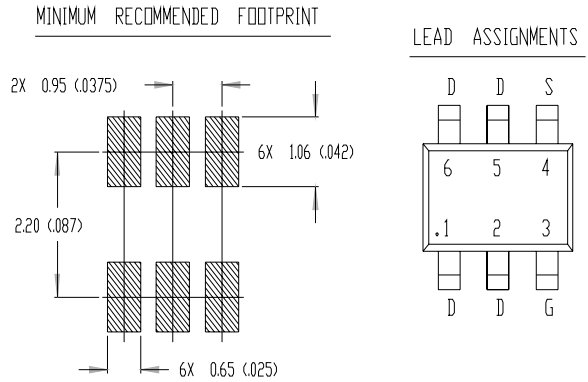
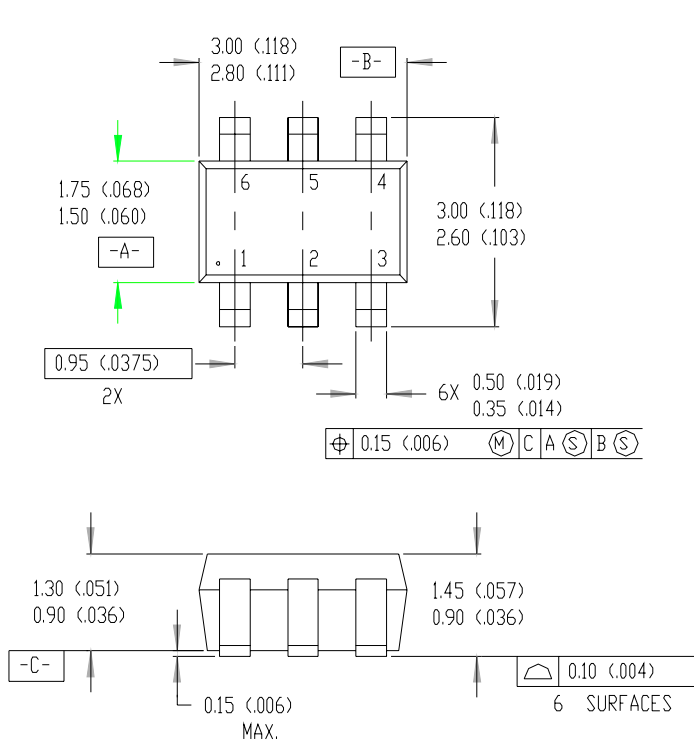


**Fig 19a.** Switching Time Test Circuit

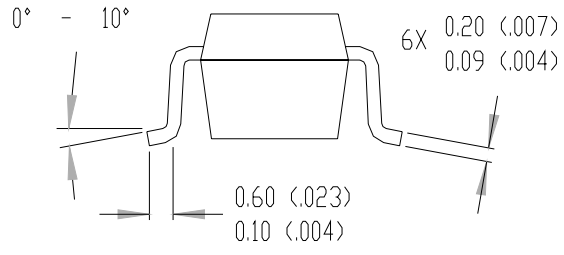


**Fig 19b.** Switching Time Waveforms

# TSOP-6 Package Outline

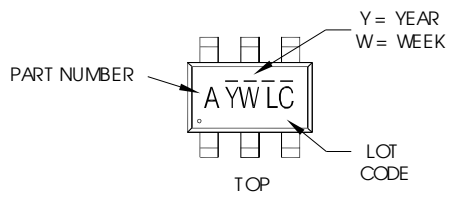


- NOTES:
1. DIMENSIONING & TOLERANCING PER ANSI Y14.5M-1982.
  2. CONTROLLING DIMENSION: MILLIMETER.
  3. DIMENSIONS ARE SHOWN IN MILLIMETERS (INCHES).



# TSOP-6 Part Marking Information

W = (1-26) IF PRECEDED BY LAST DIGIT OF CALENDAR YEAR



- PART NUMBER CODE REFERENCE:
- A = SI3443DV
  - B = IRF5800
  - C = IRF5850
  - D = IRF5851
  - E = IRF5852
  - F = IRF5801
  - G = IRF5803
  - H = IRF5804
  - I = IRF5805
  - J = IRF5806
  - K = IRF5810
  - N = IRF5802
  - O = IRLTS6342TRPBF
  - P = IRF58342TRPBF
  - R = IRF59342TRPBF
  - S = IRLTS2242TRPBF

Note: A line above the work week (as shown here) indicates Lead-Free.

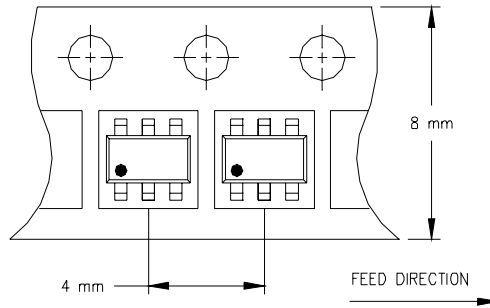
YEAR	Y	WORK WEEK	W
2001	1	01	A
2002	2	02	B
2003	3	03	C
2004	4	04	D
2005	5		
2006	6		
2007	7		
2008	8		
2009	9		
2010	0	24	X
		25	Y
		26	Z

W = (27-52) IF PRECEDED BY A LETTER

YEAR	Y	WORK WEEK	W
2001	A	27	A
2002	B	28	B
2003	C	29	C
2004	D	30	D
2005	E		
2006	F		
2007	G		
2008	H		
2009	J		
2010	K	50	X
		51	Y
		52	Z

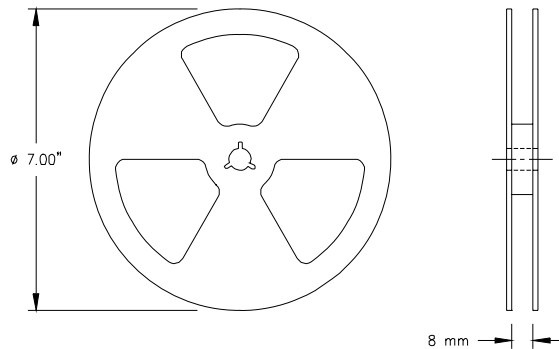
Note: For the most current drawing please refer to IR website at: <http://www.irf.com/package/>

## TSOP-6 Tape & Reel Information



**NOTES:**

1. OUTLINE CONFORMS TO EIA-481 & EIA-541.



**NOTES:**

1. OUTLINE CONFORMS TO EIA-481 & EIA-541.

### Qualification information<sup>†</sup>

Qualification level	Consumer <sup>††</sup> (per JEDEC JESD47F <sup>†††</sup> guidelines)	
Moisture Sensitivity Level	TSOP-6	MSL 1 (per JEDEC J-STD-020D <sup>†††</sup> )
RoHS compliant	Yes	

<sup>†</sup> Qualification standards can be found at International Rectifier's web site

<http://www.irf.com/product-info/reliability>

<sup>††</sup> Higher qualification ratings may be available should the user have such requirements.

Please contact your International Rectifier sales representative for further information:

<http://www.irf.com/whoto-call/salesrep/>

<sup>†††</sup> Applicable version of JEDEC standard at the time of product release.

Data and specifications subject to change without notice.

International  
**IR** Rectifier

IR WORLD HEADQUARTERS: 233 Kansas St., El Segundo, California 90245, USA Tel: (310) 252-7105

TAC Fax: (310) 252-7903

Visit us at [www.irf.com](http://www.irf.com) for sales contact information.09/2011

[www.irf.com](http://www.irf.com)