

Chip Inductor; CIH Series High Frequency Type



CIH series has dielectric material and 100% Ag as an internal conductor
Therefore, it has high Q and |Z| at high frequency
It is possible to use for high frequency over 100 MHz

General Features

- Lowest value of DC Resistance, Good Property of **Q** and high **SRF**
- Possible to use at the range over 100 MHz
- Monolithic structure for high reliability

Applications

- Mobile Communication systems, noise suppression at high frequency and impedance matching

Part Numbering

<u>CI</u>	<u>H</u>	<u>03</u>	<u>T</u>	<u>6N8</u>	<u>J</u>	<u>N</u>	<u>C</u>
①	②	③	④	⑤	⑥	⑦	⑧

① Samsung Multilayer Chip Inductor/Beads

② SERIES CODE

CODE	DESCRIPTION OF CODE
H	Chip Inductor for High frequency

③ DIMENSION

CODE	DIMENSION(L xT)
03	0.6x0.3
05	1.0x0.5
10	1.6x0.8
21	2.0x1.25

④ MATERIAL CODE

CODE	DESCRIPTION OF CODE	APPLICATION
T	Characteristics of Dielectric glass powder	CIH series

⑤ NOMINAL INDUCTANCE

The nominal inductance value is expressed in micro-Henry(μ H) or nano-Henry(nH) and identified by three-digit number, first two digits represent significant figures and last digit specifies the number of zeros to follow. The letter 'R' means the μ H and is used as the decimal point. The letter 'N' means the nH.

example)

100 : $10 \times 10^0 = 10\mu\text{H}$
1R5 : $1.5 \mu\text{H}$
R10 : $0.1 \mu\text{H} = 100 \text{ nH}$
4N7 : 4.7 nH

⑥ INDUCTANCE TOLERANCE

CODE	DESCRIPTION OF CODE	CODE	DESCRIPTION OF CODE
S	± 0.3 nH	J	$\pm 5\%$
K	$\pm 10\%$	C	± 0.2 nH

⑦ THICKNESS OPTION

CODE	DESCRIPTION OF CODE
N	Standard thickness
A	Thinner than standard thickness
B	Thicker than standard thickness

⑧ PACKAGE TYPE

CODE	DESCRIPTION OF CODE
C	Paper taping type
E	Embossed (Plastic) taping type

APPEARANCE AND DIMENSION

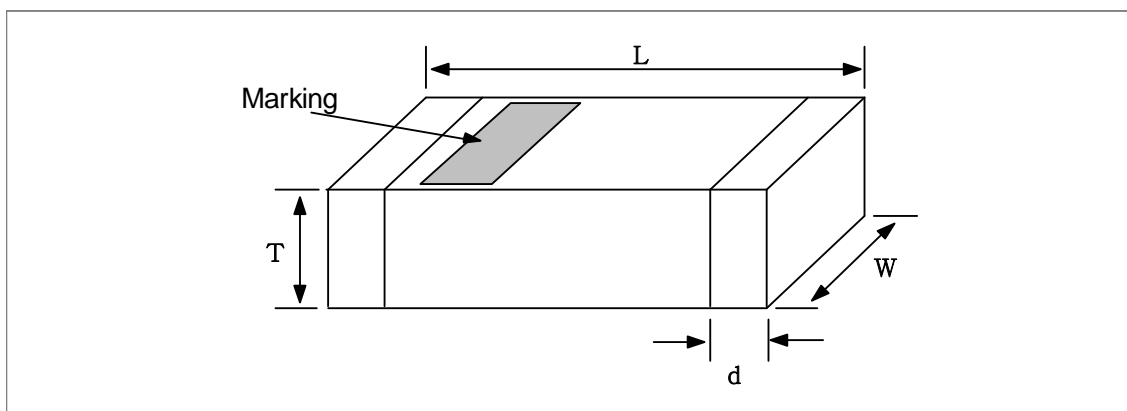

CODE	EIA CODE	DIMENSION (mm)			
		L	W	T	d
03	0201	0.6 ± 0.03	0.3 ± 0.03	0.3 ± 0.03	0.15 ± 0.05
05	0402	1.0 ± 0.05	0.5 ± 0.05	0.5 ± 0.05	0.25 ± 0.1
10	0603	1.6 ± 0.15	0.8 ± 0.15	0.8 ± 0.15	0.3 ± 0.2
21	0805	$2.0+0.3/-0.1$	1.25 ± 0.2	0.85 ± 0.2 $1.0+0.2/-0.3$	0.5 ± 0.3

CHARACTERISTIC LINE UP

● CIH 0603 (0201) Type

Ordering code	Inductance [nH]	Q min.			Self-resonant Frequency [MHz] min.	DC. resistance [Ω] max.	Rated current [mA]max.
		100MHz	800MHz	1000MHz			
CIH 03T 1N0 S	1.0±0.3nH	6	20	24	13000	0.14	300
CIH 03T 1N2 S	1.2±0.3nH	6	20	24	10000	0.14	250
CIH 03T 1N5 S	1.5±0.3nH	6	20	23	10000	0.18	230
CIH 03T 1N8 S	1.8±0.3nH	6	20	23	10000	0.19	200
CIH 03T 2N2 S	2.2±0.3nH	6	20	22	8800	0.22	200
CIH 03T 2N7 S	2.7±0.3nH	7	20	22	7700	0.25	200
CIH 03T 3N3 □	3.3±10%, 0.3nH	7	20	22	6700	0.30	200
CIH 03T 3N9 □	3.9±10%, 0.3nH	7	20	22	6000	0.30	200
CIH 03T 4N7 □	4.7±10%, 0.3nH	7	19	21	5300	0.40	200
CIH 03T 5N6 □	5.6±10%, 0.3nH	7	19	21	4600	0.40	200
CIH 03T 6N8 □	6.8±5%,10%	7	18	20	4100	0.48	150
CIH 03T 8N2 □	8.2±5%,10%	7	18	19	3400	0.55	150
CIH 03T 10N □	10.0±5%,10%	7	17	18	3300	0.63	150
CIH 03T 12N □	12.0±5%,10%	7	17	18	3000	0.70	150
CIH 03T 15N □	15.0±5%,10%	7	16	17	2700	0.80	100
CIH 03T 18N □	18.0±5%,10%	7	18	19	2100	0.90	100
CIH 03T 22N □	22.0±5%,10%	7	15	16	1800	1.2	100
CIH 03T 27N □	27.0±5%,10%	6	14	15	1800	1.8	50
CIH 03T 33N □	33.0±5%,10%	6	14	14	1700	2.1	50
CIH 03T 39N □	39.0±5%,10%	6	13	12	1500	2.4	50
CIH 03T 47N □	47.0±5%,10%	6	12	11	1300	2.8	50
CIH 03T 56N □	56.0±5%,10%	6	11	10	1100	3.0	50

□ : Tolerance (C: ± 0.2nH; S: ±0.3nH; J: ± 5%)

*Test equipment : Agilent E49919A+16196C

● CIH 1005 (0402) Type

Part No.	Inductance (nH) @100MHz	Q (typical.)			SRF (MHz) Min.	DC resistance (Ω) Max.	Rated current (mA) Max.
		100MHz	800MHz	1800MHz			
CIH 05T 1N0 S	1.0±0.3nH	8	20	30	10000	0.12	300
CIH 05T 1N2 S	1.2±0.3nH	8	20	28	10000	0.12	300
CIH 05T 1N5 S	1.5±0.3nH	8	22	35	6000	0.13	300
CIH 05T 1N8 S	1.8±0.3nH	8	22	35	6000	0.14	300
CIH 05T 2N2 S	2.2±0.3nH	8	22	35	6000	0.16	300
CIH 05T 2N7 S	2.7±0.3nH	8	22	35	6000	0.17	300
CIH 05T 3N3 □	3.3±10%, 0.3nH	8	22	35	6000	0.19	300
CIH 05T 3N9 □	3.9±10%, 0.3nH	8	22	32	4000	0.22	300
CIH 05T 4N7 □	4.7±10%, 0.3nH	8	22	32	4000	0.24	300
CIH 05T 5N6 □	5.6±10%, 0.3nH	8	22	29	4000	0.27	300
CIH 05T 6N8 □	6.8±5%, 10%	8	21	29	3900	0.32	250
CIH 05T 8N2 □	8.2±5%, 10%	8	21	29	3600	0.37	250
CIH 05T 10N □	10.0±5%, 10%	8	21	28	3200	0.42	250
CIH 05T 12N □	12.0±5%, 10%	8	20	27	2700	0.50	250
CIH 05T 15N □	15.0±5%, 10%	8	20	21	2300	0.55	250
CIH 05T 18N □	18.0±5%, 10%	8	20	15	2100	0.65	200
CIH 05T 22N □	22.0±5%, 10%	8	20	13	1900	0.80	200
CIH 05T 27N □	27.0±5%, 10%	8	17	-	1600	0.90	200
CIH 05T 33N □	33.0±5%, 10%	8	17	-	1300	1.00	200
CIH 05T 39N □	39.0±5%, 10%	8	16	-	1200	1.20	150
CIH 05T 47N □	47.0±5%, 10%	8	15	-	1000	1.30	150
CIH 05T 56N □	56.0±5%, 10%	8	-	-	750	1.40	150
CIH 05T 68N	68.0±5%, 10%	8	-	-	750	1.40	150
CIH 05T 82N	82.0±5%, 10%	8	-	-	600	1.60	100
CIH 05T R10	100.0±5%, 10%	8	-	-	600	1.60	100

□: Tolerance (S: ±0.3nH, J: ±5%, K: ±10%)

* Test equipment: HP4291A + HP16192A

● CIH 1608 (0603) Type

Part No.	Inductance (nH) @100MHz	Q (typical)		SRF (MHz) Min.	DC resistance (Ω) Max.	Rated current (mA) Max.
		100MHz	800MHz			
CIH 10T 1N0 S	1.0±0.3nH	8	20	10000	0.05	300
CIH 10T 1N2 S	1.2±0.3nH	8	20	10000	0.05	300
CIH 10T 1N5 S	1.5±0.3nH	8	20	6000	0.10	300
CIH 10T 1N8 S	1.8±0.3nH	8	20	6000	0.10	300
CIH 10T 2N2 S	2.2±0.3nH	8	20	6000	0.10	300
CIH 10T 2N7 S	2.7±0.3nH	10	25	6000	0.10	300
CIH 10T 3N3□	3.3±0.3nH, 10%	10	25	6000	0.12	300
CIH 10T 3N9□	3.9±0.3nH, 10%	10	27	6000	0.14	300
CIH 10T 4N7□	4.7±0.3nH, 10%	10	27	4000	0.16	300
CIH 10T 5N6□	5.6±0.3nH, 10%	10	27	4000	0.18	300
CIH 10T 6N8□	6.8±10%, 5%	10	27	4000	0.22	300
CIH 10T 8N2□	8.2±10%, 5%	10	26	3500	0.24	300
CIH 10T 10N□	10.0±10%, 5%	12	26	3400	0.26	300
CIH 10T 12N□	12.0±10%, 5%	12	24	2600	0.28	300
CIH 10T 15N□	15.0±10%, 5%	12	24	2300	0.32	300
CIH 10T 18N□	18.0±10%, 5%	12	24	2000	0.35	300
CIH 10T 22N□	22.0±10%, 5%	12	25	1600	0.40	300
CIH 10T 27N□	27.0±10%, 5%	12	25	1400	0.45	300
CIH 10T 33N□	33.0±10%, 5%	12	24	1200	0.55	300
CIH 10T 39N□	39.0±10%, 5%	12	20	1100	0.60	300
CIH 10T 47N□	47.0±10%, 5%	12	20	900	0.77	300
CIH 10T 56N□	56.0±10%, 5%	12	20	900	0.75	300
CIH 10T 68N□	68.0±10%, 5%	12	¹⁾ 20	700	0.85	300
CIH 10T 82N□	82.0±10%, 5%	12	¹⁾ 20	600	0.95	300
CIH 10T R10□	100.0±10%, 5%	12	¹⁾ 20	600	1.00	300
CIH 10T R12□	120.0±10%, 5%	²⁾ 8	-	500	1.20	300
CIH 10T R15□	150.0±10%, 5%	²⁾ 8	-	500	1.20	300
CIH 10T R18□	180.0±10%, 5%	²⁾ 8	-	400	1.30	300
CIH 10T R22□	220.0±10%, 5%	²⁾ 8	-	400	1.50	300
CIH 10T R27□	270.0±10%, 5%	²⁾ 8	-	400	1.50	300

□: Tolerance (S: ±0.3nH, J: ±5%, K: ±10%)

※ Test equipment: HP4291A + HP16092A + In-house Jig

● CIH 2012 (0805) Type

Part No.	Thickness (mm)	Inductance (nH)	Q Min.	L, Q test Frequency (MHZ)	SRF (MHZ) Min.	DC resistance (Ω) Max.	Rated current (mA) Max.
CIH 21T 1N5 S	0.85±0.2	1.5±0.3nH	10	100	4000	0.10	300
CIH 21T 1N8 S	0.85±0.2	1.8±0.3nH	10	100	4000	0.10	300
CIH 21T 2N2 S	0.85±0.2	2.2±0.3nH	10	100	4000	0.10	300
CIH 21T 2N7 S	0.85±0.2	2.7±0.3nH	12	100	4000	0.10	300
CIH 21T 3N3□	0.85±0.2	3.3±0.3nH, 10%	12	100	4000	0.13	300
CIH 21T 3N9□	0.85±0.2	3.9±0.3nH, 10%	12	100	4000	0.15	300
CIH 21T 4N7□	0.85±0.2	4.7±0.3nH, 10%	12	100	3500	0.20	300
CIH 21T 5N6□	0.85±0.2	5.6±0.3nH, 10%	15	100	3200	0.23	300
CIH 21T 6N8□	0.85±0.2	6.8±10%, 5%	15	100	2800	0.25	300
CIH 21T 8N2□	0.85±0.2	8.2±10%, 5%	15	100	2400	0.28	300
CIH 21T 10N□	0.85±0.2	10.0±10%, 5%	15	100	2100	0.30	300
CIH 21T 12N□	0.85±0.2	12.0±10%, 5%	15	100	1900	0.35	300
CIH 21T 15N□	0.85±0.2	15.0±10%, 5%	15	100	1600	0.40	300
CIH 21T 18N□	0.85±0.2	18.0±10%, 5%	15	100	1500	0.45	300
CIH 21T 22N□	0.85±0.2	22.0±10%, 5%	18	100	1400	0.50	300
CIH 21T 27N□	0.85±0.2	27.0±10%, 5%	18	100	1300	0.55	300
CIH 21T 33N□	0.85±0.2	33.0±10%, 5%	18	100	1200	0.60	300
CIH 21T 39N□	0.85±0.2	39.0±10%, 5%	18	100	1000	0.65	300
CIH 21T 47N□	1.00 ^{+0.2} / _{-0.3}	47.0±10%, 5%	18	100	900	0.70	300
CIH 21T 56N□	1.00 ^{+0.2} / _{-0.3}	56.0±10%, 5%	18	100	800	0.75	300
CIH 21T 68N□	1.00 ^{+0.2} / _{-0.3}	68.0±10%, 5%	18	100	700	0.80	300
CIH 21T 82N□	1.00 ^{+0.2} / _{-0.3}	82.0±10%, 5%	18	100	600	0.90	300
CIH 21T R10□	1.00 ^{+0.2} / _{-0.3}	100.0±10%, 5%	18	100	600	0.90	300
CIH 21T R12□	1.00 ^{+0.2} / _{-0.3}	120.0±10%, 5%	13	50	500	0.95	300
CIH 21T R15□	1.00 ^{+0.2} / _{-0.3}	150.0±10%, 5%	13	50	500	1.00	300
CIH 21T R18□	1.00 ^{+0.2} / _{-0.3}	180.0±10%, 5%	13	50	400	1.00	300
CIH 21T R22□	1.00 ^{+0.2} / _{-0.3}	220.0±10%, 5%	12	50	350	1.20	300
CIH 21T R27□	1.00 ^{+0.2} / _{-0.3}	270.0±10%, 5%	12	50	300	1.30	300
CIH 21T R33□	1.00 ^{+0.2} / _{-0.3}	330.0±10%, 5%	12	50	250	1.40	300
CIH 21T R39□	1.00 ^{+0.2} / _{-0.3}	390.0±10%, 5%	10	50	250	1.50	300
CIH 21T R47□	1.00 ^{+0.2} / _{-0.3}	470.0±10%, 5%	10	50	200	1.50	300

□: Tolerance (S: ±0.3nH, J: ±5%, K: ±10%)

※ Test equipment: HP4291A + HP16092A + In-house Jig

RELIABILITY TEST CONDITION

ITEM	PERFORMANCE			TEST CONDITION
	CIL	CIH10/21	CIH05	
1. OPERATING TEMPERATURE RANGE	-40 to +85°C		-55 to +125°C	-
2. STORAGE TEMPERATURE RANGE	-40 to +85°C		-55 to +125°C	-
3. INDUCTANCE / Q	SEE THE SECTION OF ELECTRICAL PROPERTIES.			<ul style="list-style-type: none"> - MEASURING FREQUENCY : 1 to 100MHz (DEPENDS ON THE ITEMS) - MEASURING EQUIPMENT, TEST FIXTURE : HP4291A/B + HP16193A (CIL SERIES) HP4291A/B + HP16092A + IN-HOUSE MADE JIG (CIH 10/21 SERIES) HP4291A/B + HP16192A (CIH 05 SERIES) - SOURCE OSC LEVEL : 30 mV (CIL SERIES) 112 mV (CIH SERIES)
4. DC RESISTANCE	SEE THE SECTION OF ELECTRICAL PROPERTIES.			- MEASURING EQUIPMENT : HP4338A/B
5. SELF RESONANCE FREQUENCY (SRF)	SEE THE SECTION OF ELECTRICAL PROPERTIES.			<ul style="list-style-type: none"> - MEASURING EQUIPMENT : HP4291A + HP16193A (CIL SERIES) HP8719C (CIH SERIES)
6. HIGH TEMPERATURE TEST	NO APPARENT DAMAGE. INDUCTANCE CHANGE TO BE WITHIN ±10% TO THE INITIAL.			SOLDER THE SAMPLE ON PCB. EXPOSURE AT (T)*°C FOR 500 HOURS. 1-2 HOURS EXPOSURE AT ROOM TEMPERATURE AND HUMIDITY PRIOR TO MEASUREMENT. (*) T= 85±3 (CIL, CIH10/21) 125±3 (CIH05)
	Q VARIATION : WITHIN ±30%.	Q VARIATION : WITHIN ±20%.		
7. SOLDER HEAT RESISTANCE	NO MECHANICAL DAMAGE. REMAINING TERMINAL ELECTRODE : 70% MIN. INDUCTANCE CHANGE TO BE WITHIN ±10% TO THE INITIAL.			AFTER BEING DIPPED IN FLUX FOR 4±1 SECONDS, AND PREHEATED AT 150~180°C FOR 2~3 MIN , THE SPECIMEN SHALL BE IMMERSSED IN 60/40 TIN-LEAD ALLOY SOLDER AT 260±5°C FOR 10 ± 0.5 SECONDS.
	Q VARIATION : WITHIN ±30%.	Q VARIATION : WITHIN ±20%.		
8. SOLDERABILITY	MORE THAN 95% OF TERMINAL ELECTRODE SHOULD BE SOLDERED NEWLY.			AFTER BEING DIPPED IN FLUX FOR 4±1 SECONDS, AND PREHEATED AT 150~180°C FOR 2~3 MIN , THE SPECIMEN SHALL BE IMMERSSED IN SOLDER AT 230 ±5°C FOR 4± 1 SECONDS.

ITEM	PERFORMANCE			TEST CONDITION
	CIL	CIH10/21	CIH05	
9. THERMAL SHOCK	NO APPARENT DAMAGE. INDUCTANCE CHANGE TO BE WITHIN $\pm 10\%$ TO THE INITIAL.			- CIL SERIES -25 \leftrightarrow +85 $^{\circ}\text{C}$, 60 MINUTES EACH. 100 CYCLES. - CIH 10/21 SERIES -40 \leftrightarrow +85 $^{\circ}\text{C}$, 60 MINUTES EACH. 100 CYCLES. - CIH 05 SERIES -55 \leftrightarrow +125 $^{\circ}\text{C}$, 60 MINUTES EACH. 100 CYCLES.
	Q VARIATION : WITHIN $\pm 30\%$.	Q VARIATION : WITHIN $\pm 20\%$.		
10. MOISTURE LOADING TEST	NO APPARENT DAMAGE. INDUCTANCE CHANGE TO BE WITHIN $\pm 10\%$ TO THE INITIAL.			- TEMPERATURE : 40 $\pm 2^{\circ}\text{C}$ (CIL, CIH 10/21) 60 $\pm 2^{\circ}\text{C}$ (CIH 05) - HUMIDITY : 90 ~ 95 %RH - DURATION : 500 ± 5 HRS. - CURRENT : RATED CURRENT
	Q VARIATION : WITHIN $\pm 30\%$.	Q VARIATION : WITHIN $\pm 20\%$.		
11. HIGH TEMPERATURE LOADING	NO APPARENT DAMAGE. INDUCTANCE CHANGE TO BE WITHIN $\pm 10\%$ TO THE INITIAL.			- TEMPERATURE : 85 $\pm 2^{\circ}\text{C}$ (CIL, CIH 10/21) 125 $\pm 2^{\circ}\text{C}$ (CIH 05) - DURATION : 500 ± 5 HRS. - CURRENT : RATED CURRENT
	Q VARIATION : WITHIN $\pm 30\%$.	Q VARIATION : WITHIN $\pm 20\%$.		
12. LOW TEMPERATURE RESISTANCE	NO APPARENT DAMAGE. INDUCTANCE CHANGE TO BE WITHIN $\pm 10\%$ TO THE INITIAL.			- TEMPERATURE : -40 $\pm 2^{\circ}\text{C}$ (CIL, CIH 10/21) -55 $\pm 2^{\circ}\text{C}$ (CIH 05) - DURATION : 500 ± 5 HRS.
	Q VARIATION : WITHIN $\pm 30\%$.	Q VARIATION : WITHIN $\pm 20\%$.		
13. BENDING TEST	NO APPARENT DAMAGE.			SOLDER THE SAMPLE ON PCB, BEND TO 2mm.
	<p>Unit : mm</p>			

CIH Series

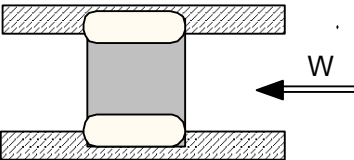
ITEM	PERFORMANCE			TEST CONDITION		
	CIL	CIH10/21	CIH05			
14. VIBRATION TEST	NO APPARENT DAMAGE. INDUCTANCE CHANGE TO BE WITHIN $\pm 10\%$ TO THE INITIAL.			APPLY VIBRATIONS IN EACH OF THE X, Y AND Z DIRECTIONS. - FREQUENCY : 10 ~ 55 ~ 10Hz - TOTAL AMPLITUDE : 1.52mm - TIME : 2 HRS. EACH (TOTAL 6 HRS.)		
	Q VARIATION : WITHIN $\pm 30\%$.	Q VARIATION : WITHIN $\pm 20\%$.				
15. DROP TEST	NO APPARENT DAMAGE. INDUCTANCE CHANGE TO BE WITHIN $\pm 10\%$ TO THE INITIAL.			DROP THE SAMPLE FROM A HEIGHT OF 1m TO CONCRETE GROUND 10 TIMES.		
	Q VARIATION : WITHIN $\pm 30\%$.	Q VARIATION : WITHIN $\pm 20\%$.				
16. TERMINAL TEST	NO INDICATION OF PEELING SHALL OCCUR ON THE TERMINAL ELECTRODE.			SIZE	W(Kgf)	TIME(SEC)
				05	0.1	30 \pm 5
				10	0.5	10 \pm 1
				21		
				31		
						

CIH Series

PACKAGING

● CARDBOARD PAPER TAPE

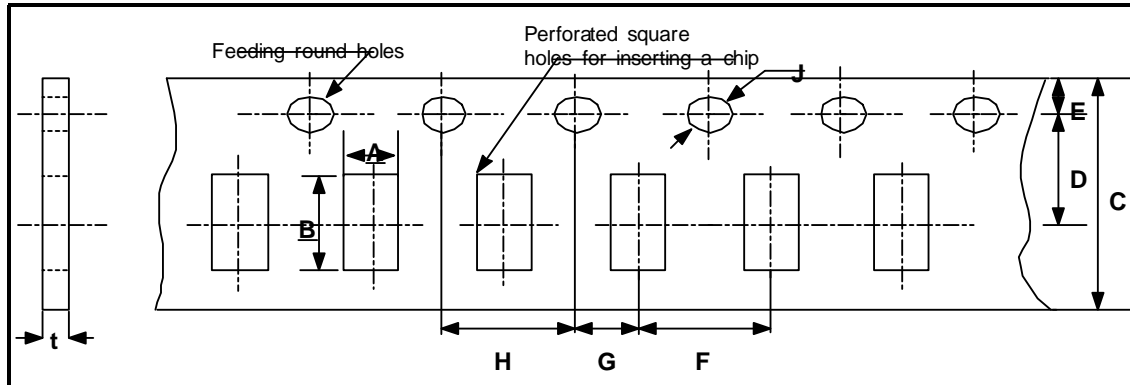

unit : mm

TYPE	A	B	C	D	E	F	G	H	J	t max.
05	0.65 ±0.1	1.15 ±0.1	8.0	3.5	1.75	2.0 ±0.05	2.0	4.0	Φ1.5	0.8
10	1.0 ±0.2	1.80 ±0.2	±0.2	±0.05	±0.1	4.0 ±0.1	±0.1	±0.1	+0.1/-0	1.1

● EMBOSSED PLASTIC TAPE

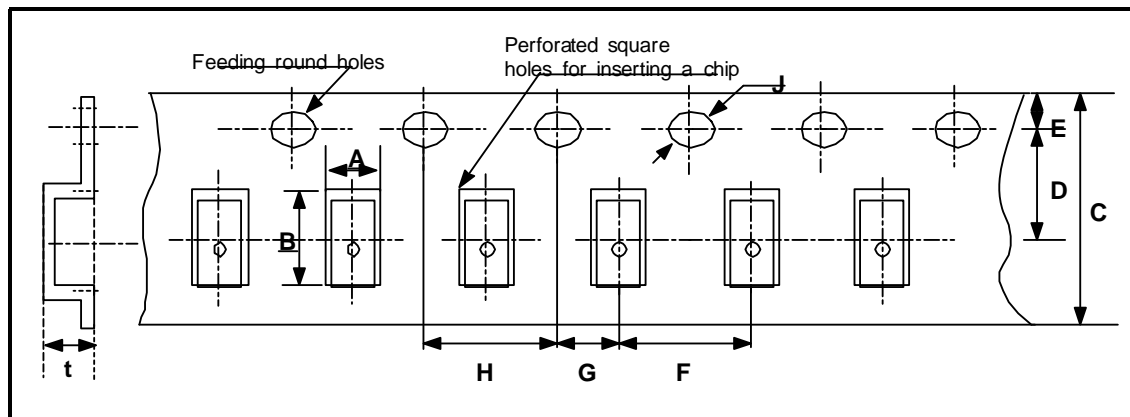

unit : mm

TYPE	A	B	C	D	E	F	G	H	J	t max.
21	0.85T									1.5
	1.0T	1.50 ±0.2	2.3 ±0.2	8.0 ±0.3	3.5 ±0.05					2.0
	1.25T					1.75 ±0.1	4.0 ±0.1	2.0 ±0.1	4.0 ±0.1	Φ1.5 +0.1/-0
31	0.6T	1.90 ±0.2	4.9 ±0.2	12.0 ±0.3	5.5 ±0.05					1.15
	1.1T									1.4

● TAPING SIZE

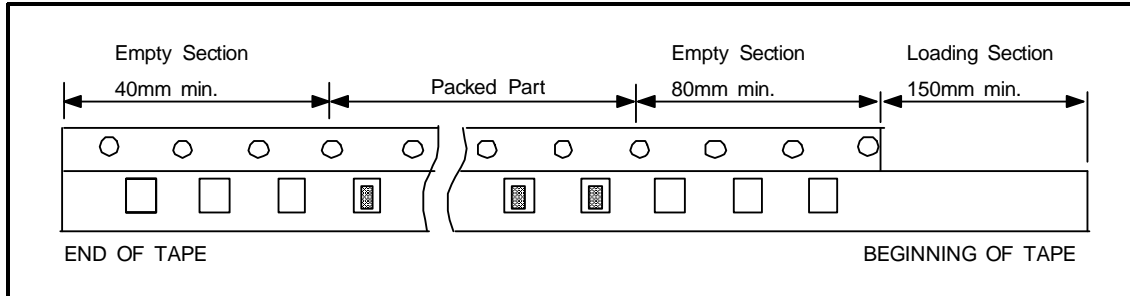

unit : pcs

Symbol	05	10	21			31	
			0.85T	1.0T	1.25T	0.6T	1.1T
7" Reel	10,000	4,000	4,000	3,000	2,000	4,000	3,000

● REEL DIMENSION

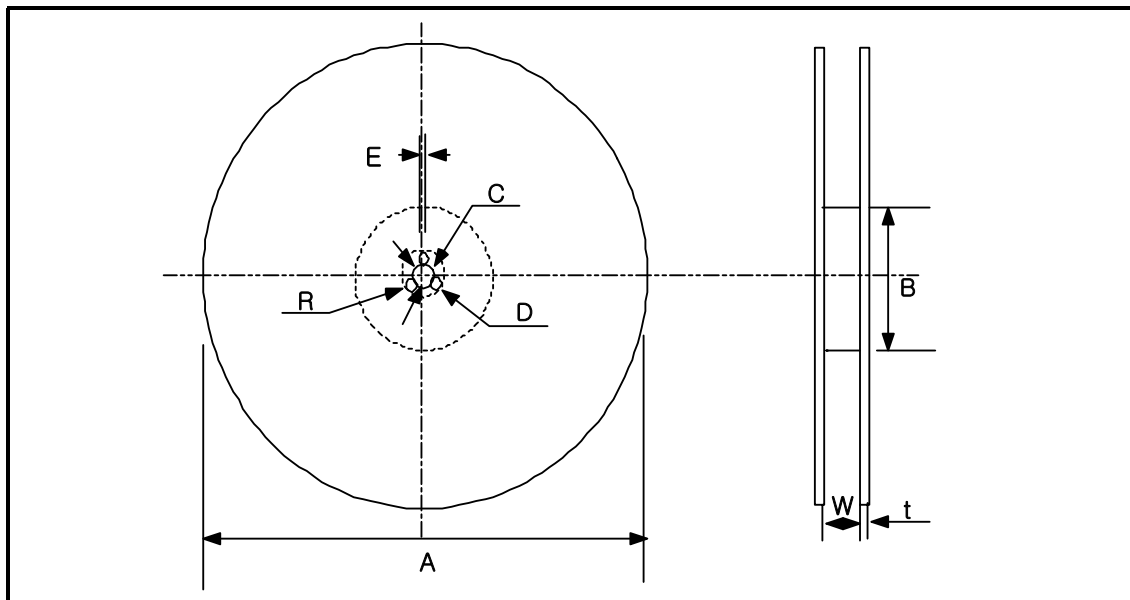

unit : mm

Tape Width	A	B	C	D	E	W	t	R
8 mm	$\phi 178 \pm 2.0$	$\phi 50 \pm 1.0$	$\phi 13 \pm 0.5$	21 ± 0.8	2.0 ± 0.5	10 ± 1.5	1.2 ± 0.5	1.0